

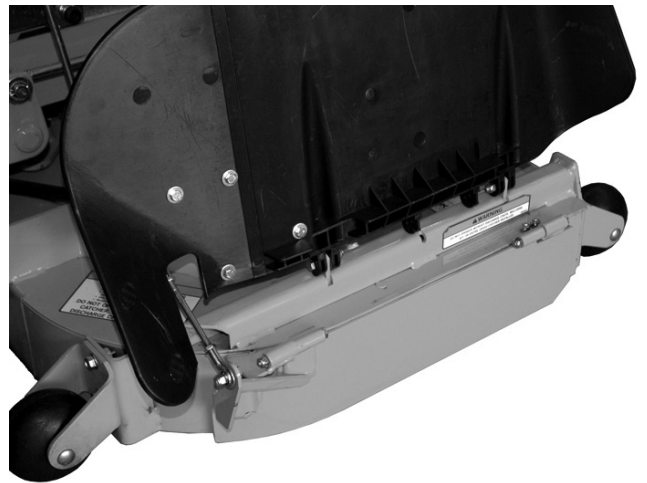

OPERATOR'S MANUAL

Electric Operator Controlled Discharge Chute

**Models: STCII/SCZ-48V E-OCDC-RF
STCII/SCZ-52V E-OCDC-RF
STCII-61V E-OCDC-RF
STTII-52V E-OCDC-RF
SCZII/STTII-61V E-OCDC-RF
SCZII/STTII-72V E-OCDC-RF
SVRII-48V E-OCDC-RF
SVRII-52V E-OCDC-RF
SVRII-61V E-OCDC-RF
SVRXL-52V E-OCDC-RF
SVRXL-61V E-OCDC-RF
SVRXL-72V E-OCDC-RF**



This manual contains the operating instructions, assembly instructions and safety information for your Scag accessory. Reading this manual can provide you with assistance in operation and installation procedures to keep your accessory performing to maximum efficiency. The specific models that this book covers are listed on the inside cover. Before operating your machine, please read all the information enclosed in the operator's manual supplied with your mower.



WARNING

FAILURE TO FOLLOW SAFE OPERATING PRACTICES MAY RESULT IN SERIOUS INJURY OR DEATH.

- Read this manual completely as well as other manuals that came with your mower.
- DO NOT operate on steep slopes. To check a slope, attempt to back up it (with the cutter deck down). If the machine can back up the slope without the wheels slipping, reduce speed and use extreme caution.
- Under no circumstances should the machine be operated on slopes greater than 15 degrees (20 degrees for SVR). ALWAYS FOLLOW OSHA APPROVED OPERATION.
- Stay two cut widths away from slopes, drop offs, ditches, water, retaining walls, avoid any slope exceeding 15 degrees (20 degrees for SVR), and do not mow under trees on slopes with the roll bar down.
- DO NOT mow on wet grass. Wet grass reduces traction and steering control.
- Keep all shields in place, especially the grass discharge chute.
- Before performing any maintenance or service, stop the machine and remove the spark plug wire and ignition key.
- If a mechanism becomes clogged, stop the engine before cleaning.
- Keep hands, feet and clothing away from power-driven parts.
- Keep others off the mower (only one person at a time)

REMEMBER - YOUR MOWER IS ONLY AS SAFE AS THE OPERATOR!

HAZARD CONTROL AND ACCIDENT PREVENTION ARE DEPENDENT UPON THE AWARENESS, CONCERN, PRUDENCE, AND PROPER TRAINING OF THE PERSONNEL INVOLVED IN THE OPERATION, TRANSPORT, MAINTENANCE, AND STORAGE OF THE EQUIPMENT.

This manual covers the operating instructions and illustrated parts list for:

STCII-48V E-OCDC-RF	with a part number of	924Z
STCII-52V E-OCDC-RF	with a part number of	925A
STCII-61V E-OCDC-RF	with a part number of	925B
STTII-52V E-OCDC-RF	with a part number of	925C
SCZII/STTII-61V E-OCDC-RF	with a part number of	925D
SCZII/STTII-72V E-OCDC-RF	with a part number of	925J
SVRII-48V E-OCDC-RF	with a part number of	924U
SVRII-52V E-OCDC-RF	with a part number of	924V
SVRII-61V E-OCDC-RF	with a part number of	924W
SVRXL-52V E-OCDC-RF	with a part number of	926MW
SVRXL-61V E-OCDC-RF	with a part number of	926NW
SVRXL-72V E-OCDC-RF	with a part number of	926PW

Table of Contents

SECTION 1 - GENERAL INFORMATION.....	1
1.1 INTRODUCTION.....	1
1.2 DIRECTION REFERENCE.....	1
1.3 SERVICING THIS ACCESSORY.....	1
1.4 SYMBOLS.....	2
SECTION 2 - SAFETY INFORMATION.....	3
2.1 INTRODUCTION.....	3
2.2 SIGNAL WORDS.....	3
2.3 OPERATION CONSIDERATIONS.....	3
2.4 E-OCDC OPERATION.....	4
2.5 BATTERY REPLACEMENT.....	5
2.6 RF MODULE PAIRING.....	5
SECTION 3 - INSTALLATION INSTRUCTIONS.....	6
3.1 STCII, SVR11-48V/52V, STT11-52V, SVRXL-52V BLOCK OFF PLATE INSTALLATION INSTRUCTIONS.....	6
3.2 SVR11/SVRXL/STCII/SCZ11/STT11-61V BLOCK OFF PLATE INSTALLATION INSTRUCTIONS.....	8
3.3 SVRXL/STT11/SCZ11-72V BLOCK OFF PLATE INSTALLATION INSTRUCTIONS.....	11
3.4 STCII RF CONTROL MODULE AND DRIVE HANDLE INSTALLATION INSTRUCTIONS.....	14
3.5 STT11 RF CONTROL MODULE AND DRIVE HANDLE INSTALLATION INSTRUCTIONS.....	16
3.6 SVR11 RF CONTROL MODULE AND DRIVE HANDLE INSTALLATION INSTRUCTIONS.....	18
3.7 SCZ11 RF CONTROL MODULE AND DRIVE HANDLE INSTALLATION INSTRUCTIONS.....	19
3.8 SVRXL RF CONTROL MODULE AND DRIVE HANDLE INSTALLATION INSTRUCTIONS.....	21
SECTION 4 - ILLUSTRATED PARTS LIST.....	25
4.1 SCAG APPROVED ATTACHMENTS AND ACCESSORIES.....	25
SVR11 / STCII / STT11 48V & 52V E-OCDC.....	26
STCII / SCZ11 / STT11 / SVR 61V & 72V E-OCDC.....	28
SVRXL 52V & 72V E-OCDC.....	30
SVRXL 61V E-OCDC.....	32
LIMITED WARRANTY- COMMERCIAL ACCESSORY.....	34

GENERAL INFORMATION

1.1 INTRODUCTION

Your E-OCDC was built to the highest standards in the industry. However, the prolonged life and maximum efficiency of your E-OCDC depends on you following the installation and operation instructions in this manual.

If additional information or service is needed, contact your Scag Power Equipment Dealer.

We encourage you to contact your dealer for repairs. All Scag dealers are informed of the latest methods to service this equipment and provide prompt and efficient service in the field or at their service shop. They carry a full line of Scag service parts.

THE REPLACEMENT OF ANY PART ON THIS PRODUCT BY OTHER THAN THE MANUFACTURER'S AUTHORIZED REPLACEMENT PART MAY ADVERSELY AFFECT THE PERFORMANCE, DURABILITY OR SAFETY OF THIS PRODUCT.

USE OF OTHER THAN ORIGINAL SCAG REPLACEMENT PARTS WILL VOID THE WARRANTY.

When ordering parts, always give the model and part number of this accessory.

USE ONLY SCAG APPROVED ATTACHMENTS AND ACCESSORIES.

Attachments and accessories manufactured by companies other than Scag Power Equipment are not approved for use on this machine. See your mowers operator's manual for a complete list of approved attachments and accessories. Be aware that using attachments with the mower may affect stability. Be sure to follow the directions found in the operator's manual.

All information is based upon product information available at the time of approval for printing. Scag Power Equipment reserves the right to make changes at any time without notice and without incurring any obligation.

1.2 DIRECTION REFERENCE

The "Right" and "Left", "Front" and "Rear" of the machine are referenced from the operator's right and left when seated in the normal operating position and facing the forward travel direction.

1.3 SERVICING THIS ACCESSORY











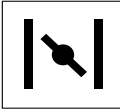



For service of this accessory during the limited warranty period, it is important to contact your Scag dealer. Any unauthorized work done to this accessory during the warranty period may void your warranty.

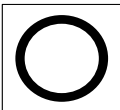

WARNING

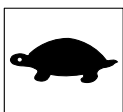
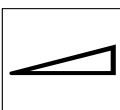
For pictorial clarity, some illustrations and figures in this manual may show shields, guards or plates open or removed. Under no circumstances should your mower be operated without these devices in place.

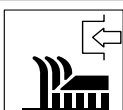
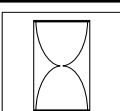
1.4 SYMBOLS

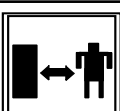
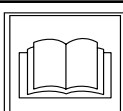
SYMBOL	DESCRIPTION	SYMBOL	DESCRIPTION
	Choke		Transmission
	Parking Brake		Spinning Blade
	On/Start		Spring Tension on Idler
	Off/Stop		Oil
	Falling Hazard		Thrown Object Hazard
	Fast		Slow
	Continuously Variable - Linear		Cutting Element - Basic Symbol
	Pinch Point		Cutting Element - Engage
	Hour meter/Elapsed Operating Hours		Cutting Element - Disengage
	Keep Bystanders Away		Read Operator's Manual

SAFETY INFORMATION

2.1 INTRODUCTION

Your mower is only as safe as the operator. Carelessness or operator error may result in serious bodily injury or death. Hazard control and accident prevention are dependent upon the awareness, concern, prudence, and proper training of the personnel involved in the operation, transport, maintenance and storage of the equipment. Make sure every operator is properly trained and thoroughly familiar with all of the controls before operating the mower. The owner/user can prevent and is responsible for accidents or injuries occurring to themselves, other people or property.

READ THIS OPERATOR'S MANUAL AND WATCH THE TIPS FOR SAFE OPERATION OF YOUR SCAG ZERO-TURN MOWER VIDEO BEFORE ATTEMPTING TO START YOUR MOWER. MAKE SURE THAT EVERYONE KNOWS WHERE THE MANUAL IS LOCATED AND KEEP A RECORD OF EACH EMPLOYEE THAT HAS READ THE MANUAL.

A replacement manual is available from your authorized Scag Service Dealer or by contacting Scag Power Equipment, Service Department at P.O. Box 152, Mayville, WI 53050 or contact us via the Internet at www.scag.com. The manual for this accessory can be downloaded by using the model and part number or use the contact form to make your request. Please indicate the complete model and part number of your Scag product when requesting replacement manuals.

2.2 SIGNAL WORDS



This symbol means **"Attention! Become Alert! Your Safety is Involved!"** The symbol is used with the following signal words to attract your attention to safety messages found on the decals on the machine and throughout this manual. The message that follows the symbol contains important information about safety. To avoid injury and possible death, carefully read the message! Be sure to fully understand the causes of possible injury or death.

SIGNAL WORD:

It is a distinctive word found on the safety decals on the machine and throughout this manual that alerts the viewer to the existence and relative degree of the hazard.

DANGER

The signal word "DANGER" denotes that an extremely hazardous situation exists on or near the machine that could result in high probability of death or irreparable injury if proper precautions are not taken.

WARNING

The signal word "WARNING" denotes that a hazard exists on or near the machine that can result in injury or death if proper precautions are not taken.

CAUTION

The signal word "CAUTION" is a reminder of safety practices on or near the machine that could result in personal injury if proper precautions are not taken.

Your safety and the safety of others depends significantly upon your knowledge and understanding of all correct operating practices and procedures of this machine.

2.3 OPERATION CONSIDERATIONS

1. Know the function of the E-OCDC control before operating the machine.

WARNING

DO NOT operate without discharge chute, mulch kit, mulch plate, OCDC, E-OCDC or entire grass catcher installed.

2. When using any attachment, never direct the discharge of material toward bystanders or allow anyone near the machine while in operation.
3. If the mower discharge ever plugs, shut off the engine, remove the ignition key, and wait for all movement to stop before removing the obstruction.

WARNING

DO NOT use your hand to dislodge the clogged discharge chute. Use a stick or other device to remove clogged material after the engine has stopped running and the blades have stopped turning.

4. Be alert for holes, rocks, roots and other hidden hazards in the terrain. Keep away from any drop-offs. Beware of overhead obstructions (low limbs, etc.), underground obstacles (sprinklers, pipes, tree roots, etc.). Cautiously enter a new area. Be alert for hidden hazards.
5. Disengage power to cutter deck before backing up. Do not mow in reverse unless absolutely necessary and then only after observation of the entire area behind the mower. If you must mow in reverse, maintain a constant lookout to the rear of the machine and mow slowly.
6. Disengage power to cutter deck before crossing roads, walks or gravel drives.
7. Mow only in daylight or good artificial light.
8. NEVER raise the deck with the blades engaged.
9. The machine and attachments should be stopped and inspected for damage after striking a foreign object, and damage should be repaired before restarting and operating the machine.
10. Keep hands and feet away from cutter blades and moving parts. Contact can injure.
11. Use care when approaching blind corners, shrubs, trees, or other objects that may obscure vision.
12. NEVER leave the machine running unattended.

2.4 E-OCDC OPERATION

The E-OCDC (Electric Operator Controlled Discharge Chute) can be raised or lowered to side discharge or block the discharge of grass clippings. Follow the steps below for proper operation of the E-OCDC.

-NOTE-

The E-OCDC is not intended to be a complete or full-time mulch system. This accessory allows the operator to temporarily close the cutter deck's discharge opening to keep clippings out of landscaping and off pavement when needed.

CLOSED DISCHARGE POSITION

In the closed position, the clippings will be temporarily blocked.

1. Press the control switch once to lock the E-OCDC into the closed position. The discharge chute will raise to allow for close trimming.

NORMAL DISCHARGE POSITION

In the open position, the clippings will side discharge.

1. Press the control switch again to lower the side discharge chute. The discharge chute will lower to the original position for safe side-discharge operation.

Section 2

2.5 BATTERY REPLACEMENT

1. Locate the RF control switch. The switch will either be located in the RH steering control lever for ride-on models or in front of the steering control levers on stand-on models.
2. Remove the switch by pulling the switch straight out of the mounting area. It may be necessary to use a flat head screwdriver to assist with the removal.
3. Locate the battery cover on the RF switch and remove the two phillip screws retaining the cover to the switch.
4. Remove the battery cover and battery.
5. Install the new 1632 battery with the positive side facing up in the sleeve in the RF switch.
6. Install the battery cover and screws.
7. Install the switch back into the RH drive handle.
8. Dispose of the old battery properly.

2.6 RF MODULE PAIRING

-NOTE-

The pairing procedure will need to be completed whenever the RF control switch or control module is replaced.

1. Press the green pair switch on the RF control module located on the side of the machine by the discharge opening.
2. Press the RF control switch within 3 seconds of pressing the green pair switch. The green pair switch light on the control box will flash once, indicating it has been paired successfully. If the handle bar switch is not pressed within 3 seconds, the pairing process will be canceled and the light will not flash. Repeat steps 1 and 2 if this occurs to complete the pairing process.

INSTALLATION INSTRUCTIONS

3.1 STCII, SVRII-48V/52V, STTII-52V, SVRXL-52V BLOCK OFF PLATE INSTALLATION INSTRUCTIONS

Prepare the machine for easy and safe access to the work area. Park the machine on a flat, level surface and apply the parking brake. Remove the ignition key and disconnect the positive and negative cables from the battery. Maintain all safety related work procedures. Always wear hand and eye protection.

1. Remove the discharge chute from the machine. See Figure 3-1.
2. Retain the discharge chute and mounting hardware for future use.

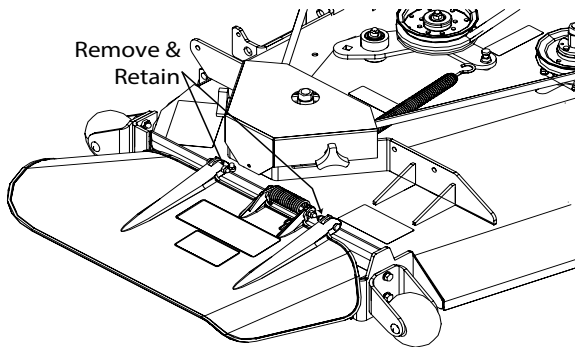

Figure 3-1. Removing the Discharge Chute

3. Remove the turbo baffle from the cutter deck. See Figure 3-2.
4. Retain the turbo baffle and mounting hardware for future use.

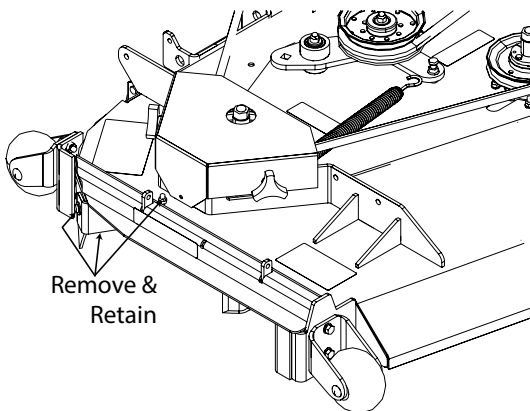

Figure 3-2. Removing the Turbo Baffle

5. Install the rear hinge bracket to the cutter deck using one (1) 5/16-18 x 1" bolt, one (1) 5/16" flatwasher and one (1) 5/16-18 elastic stop nut. Do not tighten the hardware. See Figure 3-3.

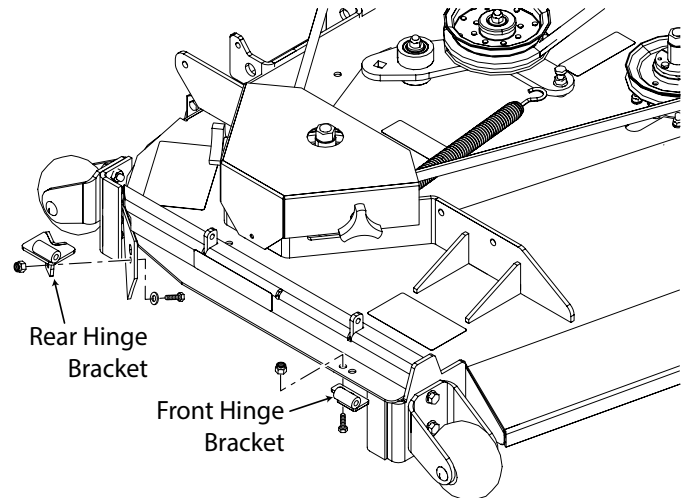

Figure 3-3. Hinge Weldment Installation

6. Hold the rear hinge bracket tight to the cutter deck.
7. Using the rear hinge bracket as a guide, mark, center punch and drill the bottom mounting bolt hole for the rear hinge bracket using an 11/32" drill bit.
8. Install one (1) 5/16-18 x 3/4" bolt and one (1) 5/16-18 elastic stop nut. Do not tighten the hardware.
9. Install the template to locate the mounting hole for the pivot assembly. Secure the template to the cutter deck using the turbo baffle mounting hardware removed in step 5. See Figure 3-4, Page 7.
10. Hold the template against the discharge chute mounting rail and tighten the hardware. See Figure 3-4, Page 7.
11. Using the template as a guide, center punch and drill one mounting hole using an 11/32" drill bit. See Figure 3-4, Page 7.
12. Remove the template from the cutter deck.
13. Carefully lay out the remaining mounting holes for the front hinge bracket in the cutter deck. See Figure 3-4, Page 7.
14. Center punch and drill the holes using an 11/32" drill bit.

Section 3

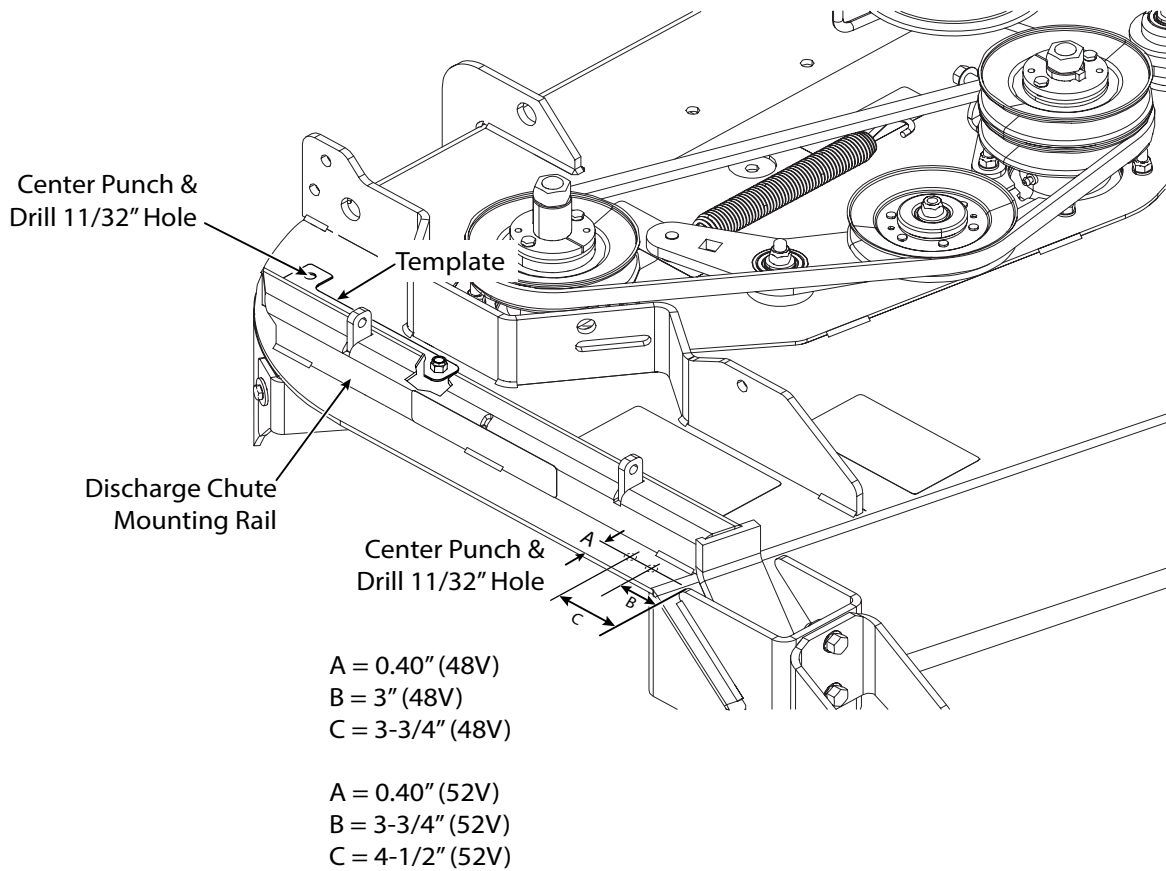
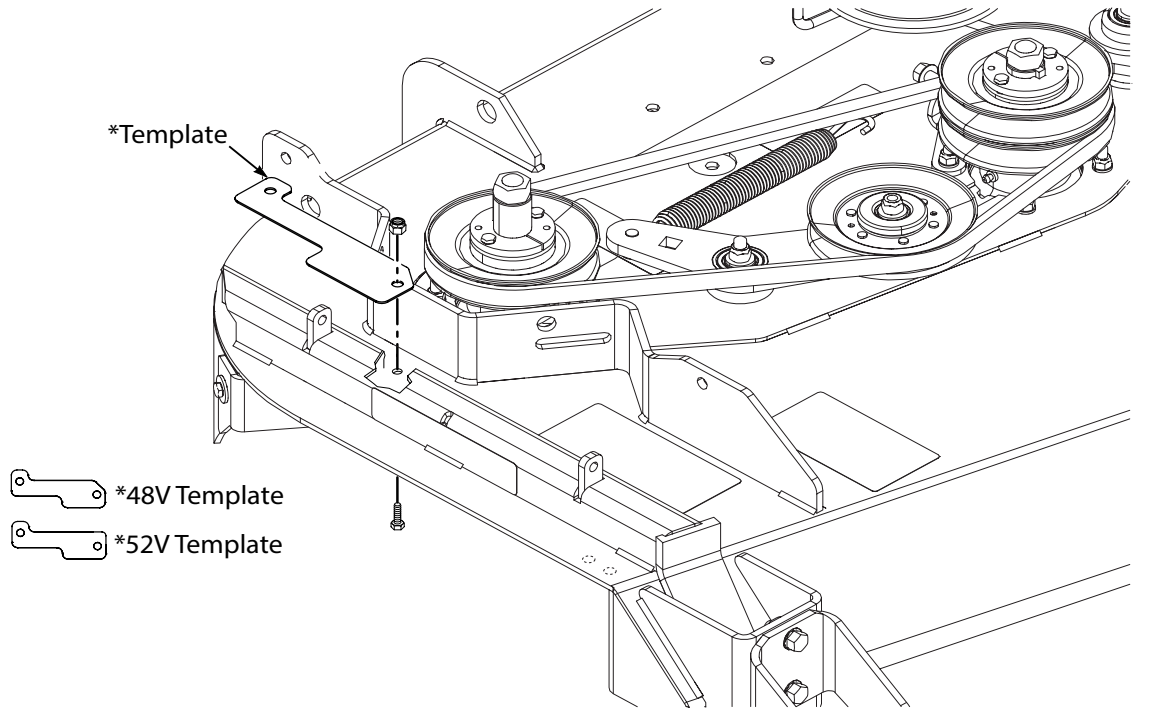

Figure 3-4. Locating and Drilling the Mounting Holes for STC/STCII/SCZ-48V

15. Install the front hinge bracket to the cutter deck using two (2) 5/16-18 x 3/4" bolts and two (2) 5/16-18 elastic stop nuts. See Figure 3-3, Page 6. Do not tighten the hardware.
16. Install the block off plate weldment to the front and rear hinge brackets using two (2) 5/16-18 x 3-1/2" bolts and two (2) 5/16-18 elastic stop nuts. See Figure 3-5. Do not tighten the bolts completely. Secure the hardware so the block off plate weldment moves freely.

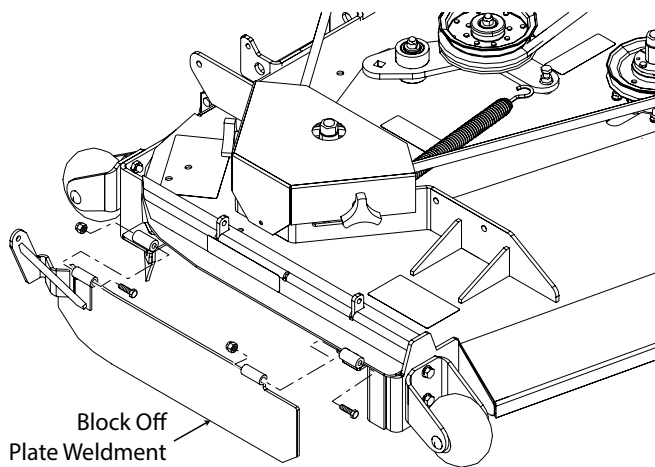

Figure 3-5. Block Off Plate Weldment Installation

17. Tighten the mounting hardware securing the front and rear hinge brackets.
18. Install the E-OCDC pivot assembly to the cutter deck. Secure using one (1) 5/16-18 x 1" bolt and one (1) 5/16-18 flanged elastic stop nut. Do not tighten hardware at this time. See Figure 3-6.
19. Using the E-OCDC pivot assembly as a guide, locate and drill the required holes in the discharge chute mounting rail and cutter deck using an 11/32" drill bit. See Figure 3-6.

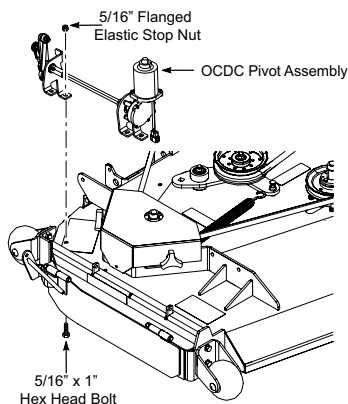

Figure 3-6.

20. Secure the E-OCDC pivot assembly to the discharge chute mounting rail and cutter deck using two (2) 5/16-18 x 1" bolts, two (2) 5/16-18 flanged elastic stop nuts and one (1) 3/8" x 1-1/4" self tapping screw. See Figure 3-7.

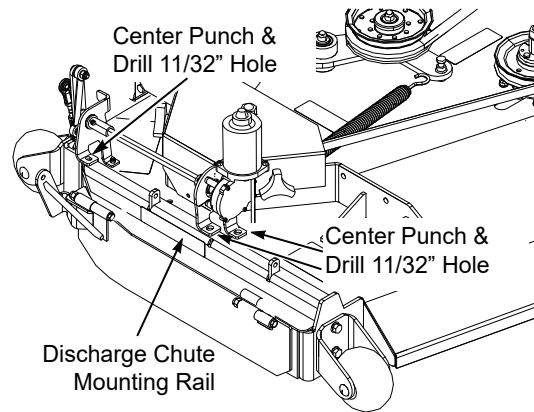

Figure 3-7.

21. Fasten the lower adjustable linkage to the block off weldment using one (1) 5/16" -18 x 1-1/4" bolt, one (1) 5/16" flat washer and one (1) 5/16" elastic stop nut. See Figure 3-8.

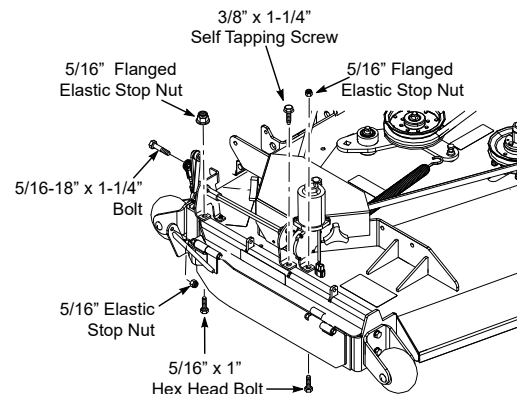

Figure 3-8.

22. Tighten the hardware installed in steps 20 and 22.

3.2 SVRII/SVRXL/STCII/SCZII/STTII-61V BLOCK OFF PLATE INSTALLATION INSTRUCTIONS

Prepare the machine for easy and safe access to the work area. Park the machine on a flat, level surface and apply the parking brake. Remove the ignition key and disconnect the positive and negative cables from the battery. Maintain all safety related work procedures. Always wear hand and eye protection.

Section 3

1. Remove the discharge chute from the machine. See Figure 3-9.
2. Retain the discharge chute and mounting hardware for future use.

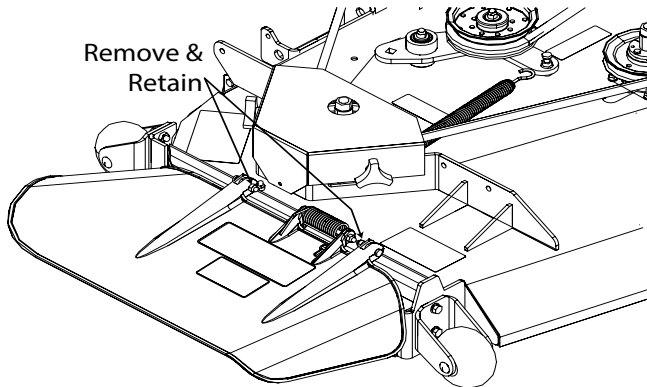

Figure 3-9. Removing the Discharge Chute

3. Remove the turbo baffle from the cutter deck. See Figure 3-8.
4. Retain the turbo baffle and mounting hardware for future use.

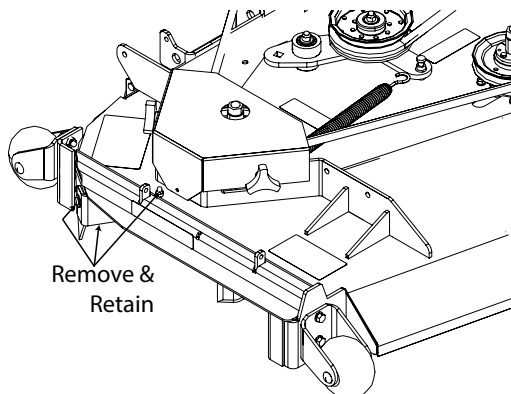

Figure 3-10. Removing the Turbo Baffle

5. Install the rear hinge bracket to the cutter deck using one (1) 5/16-18 x 1" bolt, one (1) 5/16" flatwasher and one (1) 5/16-18 elastic stop nut. Do not tighten the hardware. See Figure 3-9.

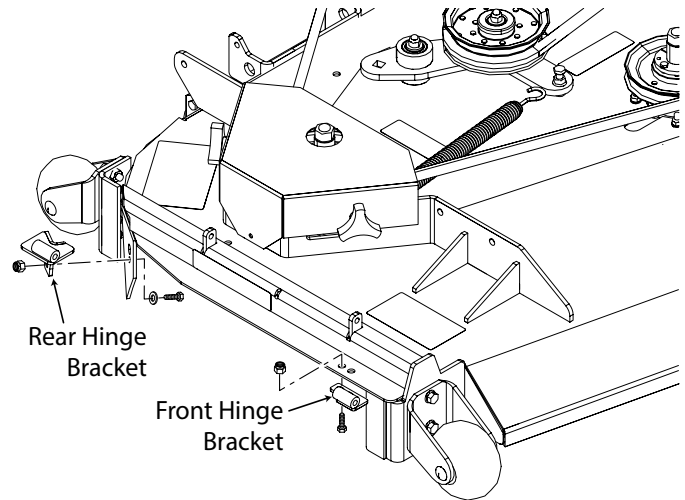

Figure 3-11. Hinge Weldment Installation

6. Hold the rear hinge bracket tight to the cutter deck.
7. Using the rear hinge bracket as a guide, mark, center punch and drill the bottom mounting bolt hole for the rear hinge bracket using an 11/32" drill bit.
8. Install one (1) 5/16-18 x 3/4" bolt and one (1) 5/16-18 elastic stop nut. Do not tighten the hardware.
9. Install the template to locate the mounting holes for the lever assembly. Secure to the cutter deck using the turbo baffle mounting hardware removed in step 5. See Figure 3-10, Page 10.
10. Hold the template against the discharge chute mounting rail and tighten the hardware. See Figure 3-10, Page 10.
11. Center punch and drill the mounting holes using an 11/32" drill bit. See Figure 3-10, Page 10.
12. Carefully lay out the remaining mounting holes for the front hinge bracket in the cutter deck. See Figure 3-10, Page 10.
13. Center punch and drill the holes using an 11/32" drill bit.

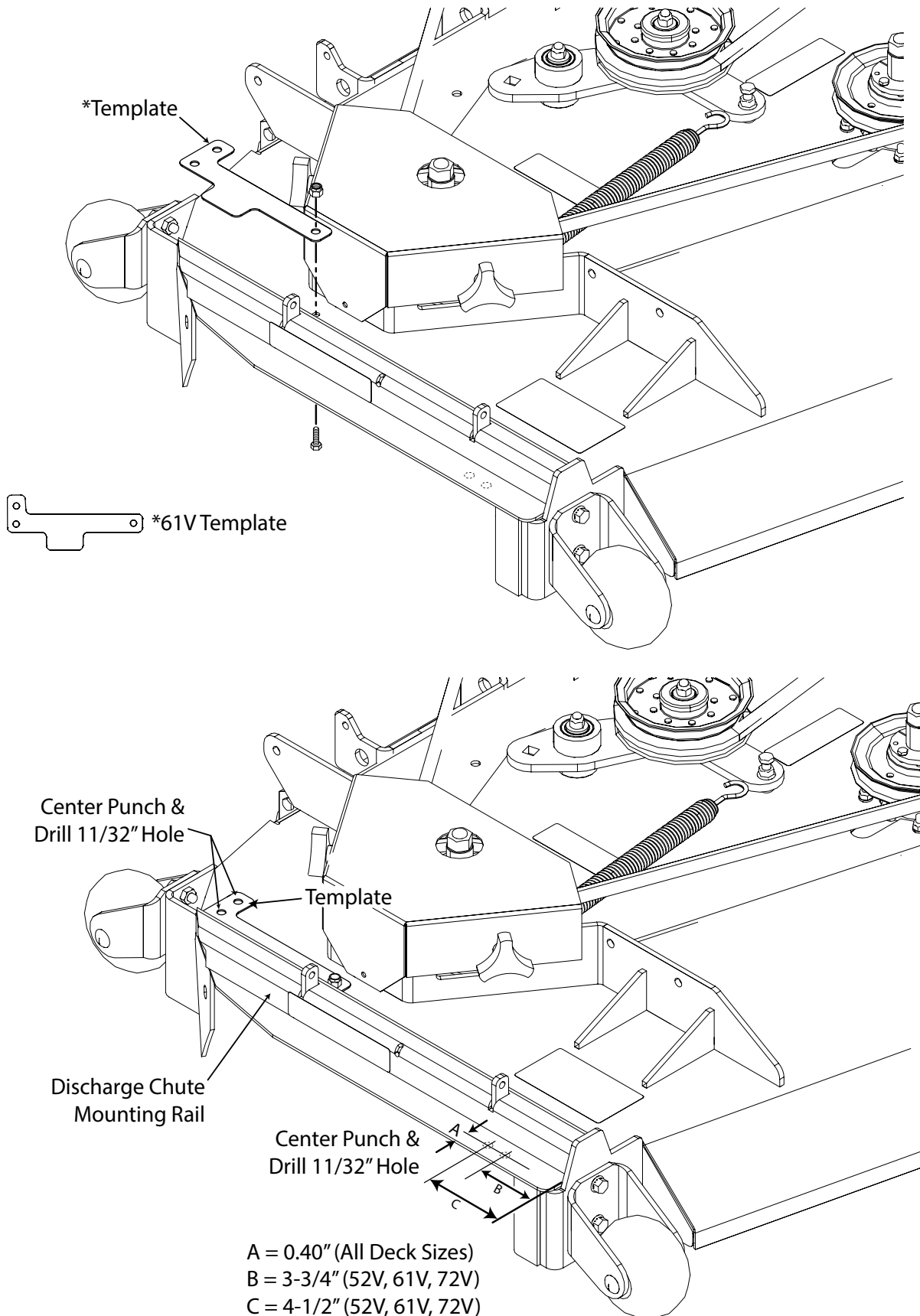

Figure 3-12. Locating and Drilling the Mounting Holes for STCII/SVRII/STTII/SCZII -61V

Section 3

14. Install the front hinge bracket to the cutter deck using two (2) 5/16-18 x 3/4" bolts and two (2) 5/16-18 elastic stop nuts. See Figure 3-9, page 9. Do not tighten the hardware.
15. Install the block off plate weldment to the front and rear hinge brackets using two (2) 5/16-18 x 3-1/2" bolts and two (2) 5/16-18 elastic stop nuts. See Figure 3-11. Do not tighten the bolts completely. Secure the hardware so the block off plate weldment moves freely.

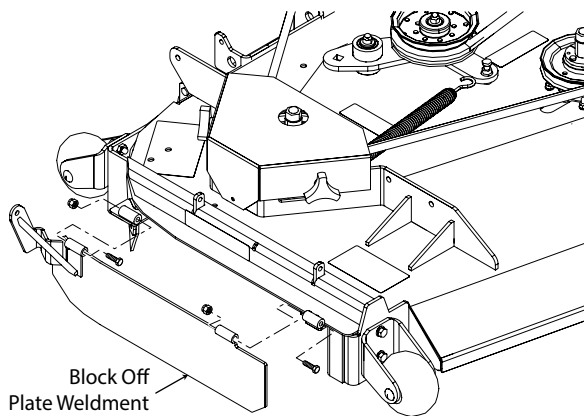

Figure 3-13. Block Off Plate Weldment Installation

16. Tighten the mounting hardware securing the front and rear hinge brackets.
17. Install the E-OCDC pivot assembly to the cutter deck. Secure using two (2) 5/16-18 x 1" bolts and two (2) 5/16-18 flanged elastic stop nuts. Do not tighten the hardware at this time. See Figure 3-12.
18. Secure the lower adjustable linkage to the block off plate weldment using one (1) 5/16" -18 x 1-1/2", one (1) spacer, and one (1) 5/16" elastic stop nut. See Figure 3-12.
19. Tighten the hardware installed in step 18 leaving a 1/16" gap between the E-OCDC pivot assembly and the discharge chute mounting rail on the cutter deck. See Figure 3 -13.

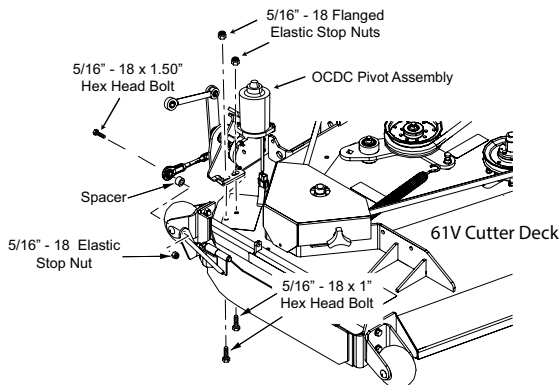

Figure 3-14. STCII/SVRII/STTII/SCZII /61V Pivot Install

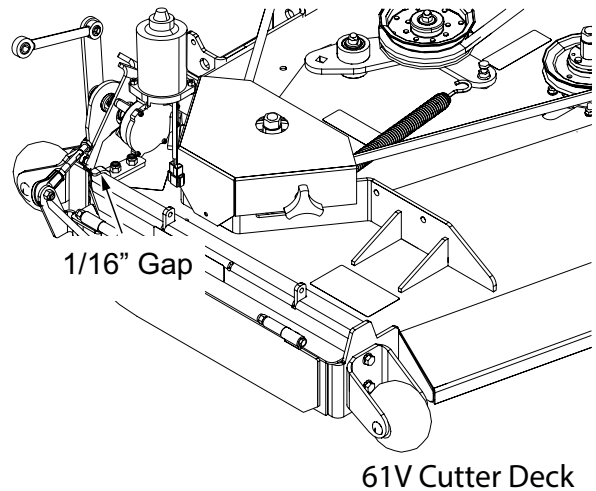

Figure 3-15. Gap Requirement

3.3 SVRXL/STTII/SCZII-72V BLOCK OFF PLATE INSTALLATION INSTRUCTIONS

Prepare the machine for easy and safe access to the work area. Park the machine on a flat, level surface and apply the parking brake. Remove the ignition key and disconnect the positive and negative cables from the battery. Maintain all safety related work procedures. Always wear hand and eye protection.

1. Remove the discharge chute from the machine. See Figure 3-14.
2. Retain the discharge chute and mounting hardware for future use.

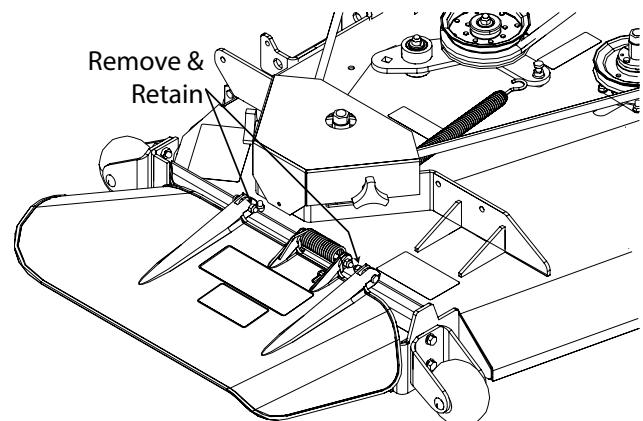

Figure 3-16. Removing the Discharge Chute

3. Remove the turbo baffle from the cutter deck. See Figure 3-15.
4. Retain the turbo baffle and mounting hardware for future use.

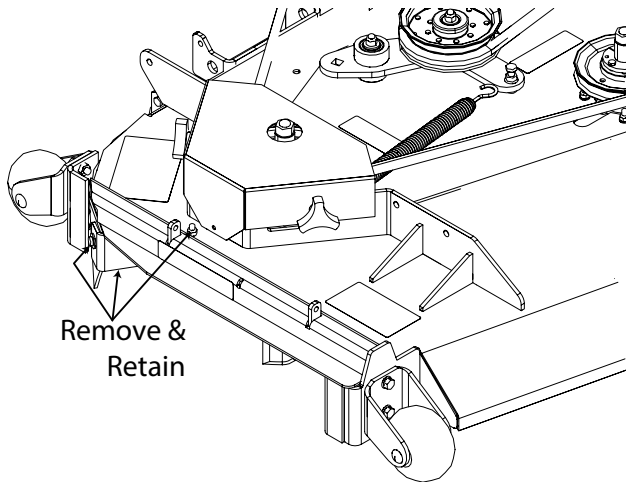

Figure 3-17. Removing the Turbo Baffle

5. Install the rear hinge bracket to the cutter deck using one (1) 5/16-18 x 1" bolt, one (1) 5/16" flatwasher and one (1) 5/16-18 elastic stop nut. Do not tighten the hardware. See Figure 3-16.

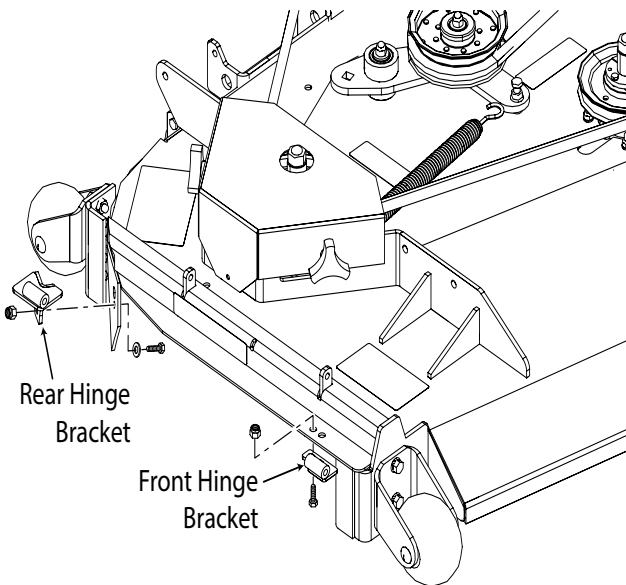

Figure 3-18. Hinge Weldment Installation

6. Hold the rear hinge bracket tight to the cutter deck.
7. Using the rear hinge bracket as a guide, mark, center punch and drill the bottom mounting bolt hole for the rear hinge bracket using an 11/32" drill bit.
8. Install one (1) 5/16-18 x 3/4" bolt and one (1) 5/16-18 elastic stop nut. Do not tighten the hardware.
9. Install the template to locate the mounting hole for the pivot assembly. Secure the template to the cutter deck using the turbo baffle mounting hardware removed in step 5. See Figure 3-18, Page 13.

10. Hold the template against the discharge chute mounting rail and tighten the hardware. See Figure 3-18, Page 13.
11. Using the template as a guide, center punch and drill two mounting holes using an 11/32" drill bit. See Figure 3-18, Page 13.
12. Remove the template from the cutter deck.
13. Carefully lay out the remaining mounting holes for the front hinge bracket in the cutter deck. See Figure 3-18 Page 13.
14. Center punch and drill the holes using an 11/32" drill bit
15. Install the front hinge bracket to the cutter deck using two (2) 5/16-18 x 3/4" bolts and two (2) 5/16-18 elastic stop nuts. See Figure 3-18. Do not tighten the hardware.
16. Install the block off plate weldment to the front and rear hinge brackets using two (2) 5/16 -18 x 3 1/2" bolts and two (2) 5/16-18 elastic stop nuts. See Figure 3-17. Do not tighten the bolts completely. Secure the hardware so the block off plate weldment moves freely.

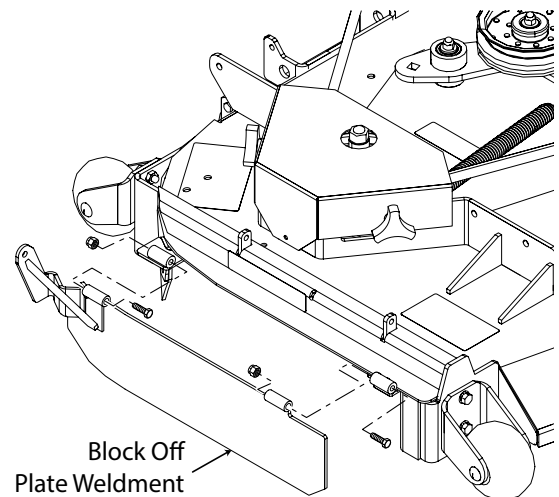

Figure 3-19. Block Off Plate Weldment Installation

17. Tighten the mounting hardware securing the front and rear hinge brackets.
18. Install the E-OCDC pivot assembly to the cutter deck. Secure using two (2) 5/16-18 x 1" bolts and two 5/16-18 flanged elastic stop nuts. See Figure 3-19.

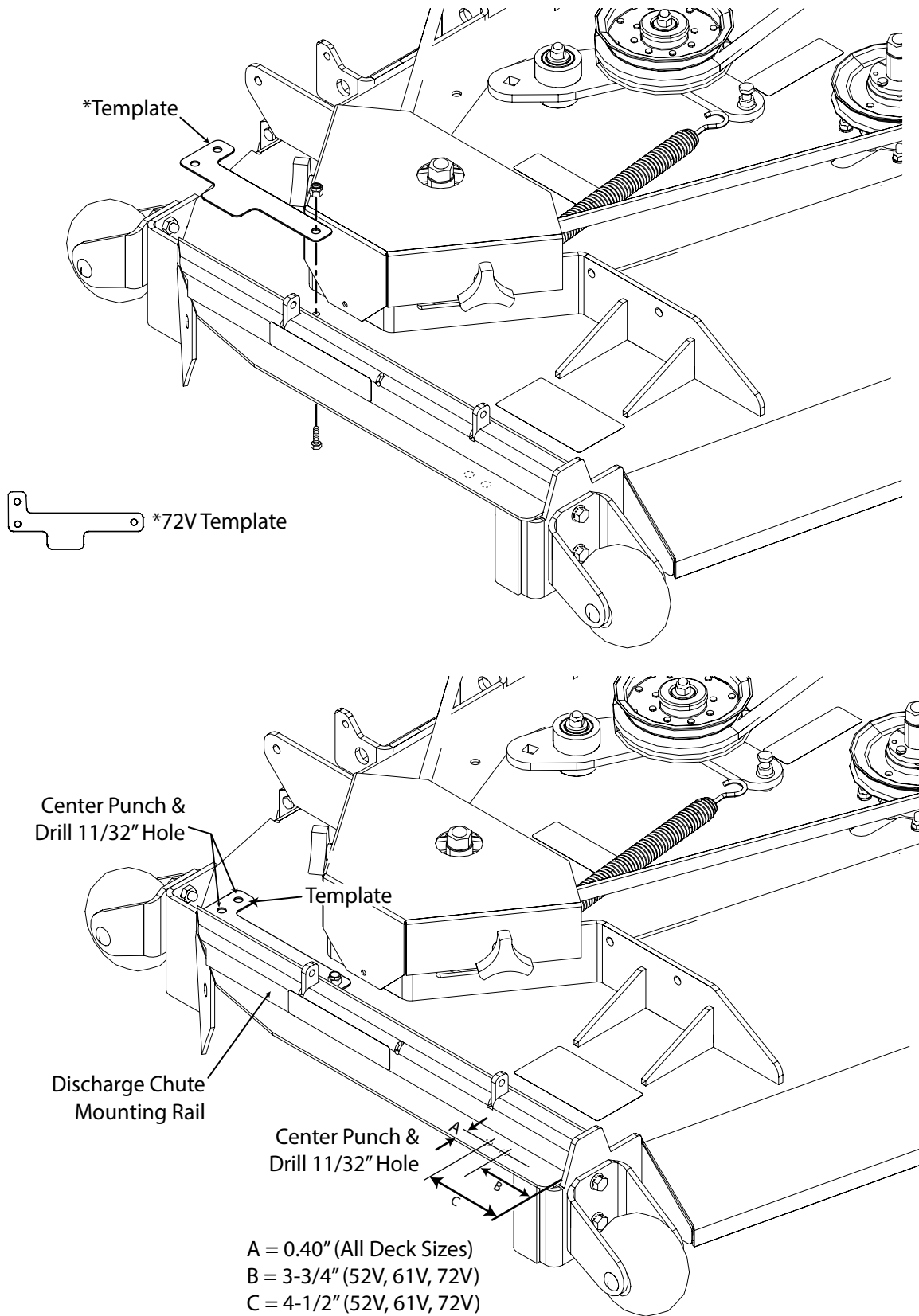

Figure 3-20. Locating and Drilling the Mounting Holes for STII/SCZII -72V

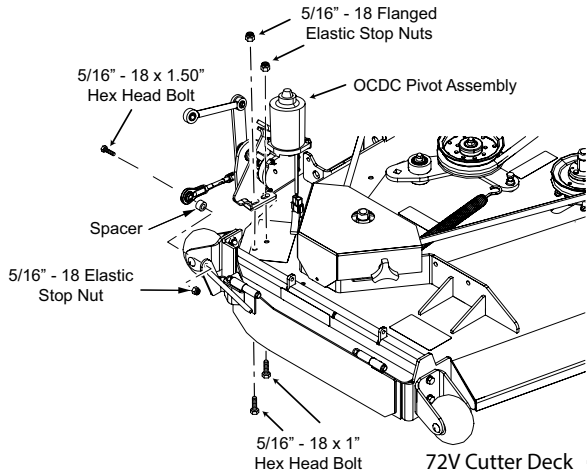

Figure 3-21. 72V OCDC Pivot Assembly Install

19. Fasten the lower control linkage of the pivot assembly to the block off weldment using one (1) 5/16-18 x 1-1/2" bolt, spacer and 5/16" elastic locknut. See Figure 3-21.
20. Leaving a 1/16" gap, tighten the hardware installed in Step 18 and 19.

3.4 STCII RF CONTROL MODULE AND DRIVE HANDLE INSTALLATION INSTRUCTIONS

Prepare the machine for easy and safe access to the work area. Park the machine on a flat, level surface and apply the parking brake. Remove the ignition key and disconnect the positive and negative cables from the battery. Maintain all safety related work procedures. Always wear hand and eye protection.

1. Remove and retain the two (2) 5/16 - 18 x 1 1/4" bolts securing the cutting height bracket to the frame. See Figure 3-20.

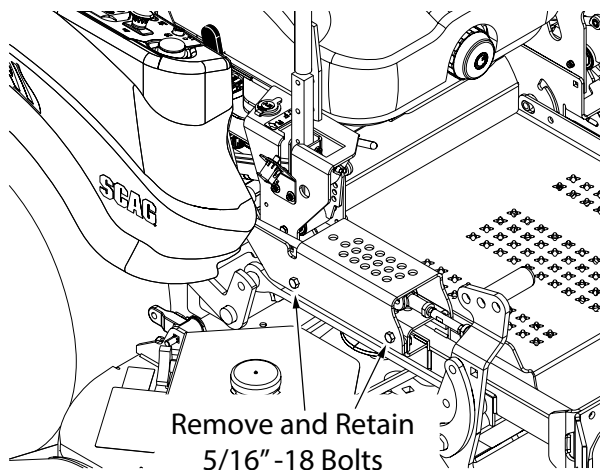

Figure 3-22. STCII Hardware Removal

2. Install the RF control module mounting bracket to the cutting height bracket using the 5/16-18 x 1 1/4" bolts removed in step 1. See Figure 3 -21.
3. Secure the RF control module and guard to the mounting bracket using two (2) 1/4-20 x 1" bolts, two 1/4" flat washers, and two (2) 1/4" - 20 elastic stop nuts. See Figure 3-21.

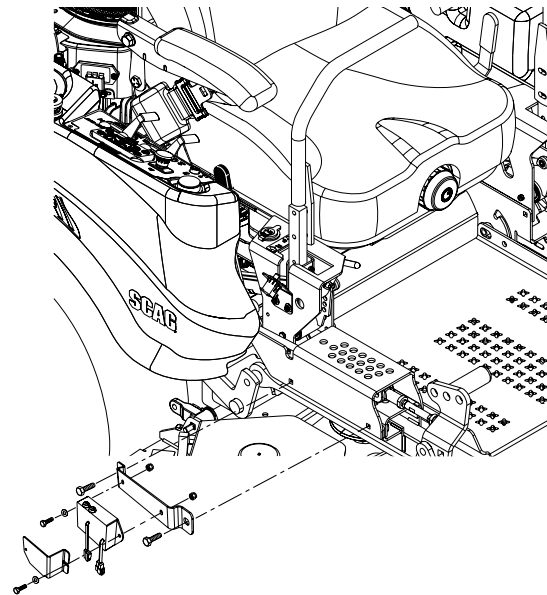

Figure 3-23. RF Module and Mounting Bracket Installation

4. Using a cable tie, retain the wires from the RF control module to the hole in the RF control module guard. See Figure 3-22.
5. Locate the "A" terminal on the key switch and install the green wire from the E-OCDC harness to the key switch. See Figure 3-22.
6. Plug the EOCD main wire harness into the RF control module. See Figure 3-22. DO NOT plug the EOCD motor harness into the RF control module at this time, this may cause movement of the linkages.
7. Install the wires from the E-OCDC harness to the battery using the red and black leads. Be sure to connect the red wire to the positive terminal first and then the black wire to the negative terminal.
8. Using the cable ties provided in the kit, secure the E-OCDC harness to prevent interference or damage to the harness.
9. Secure the relay on the E-OCDC harness to the main wire harness using a cable tie.

Section 3

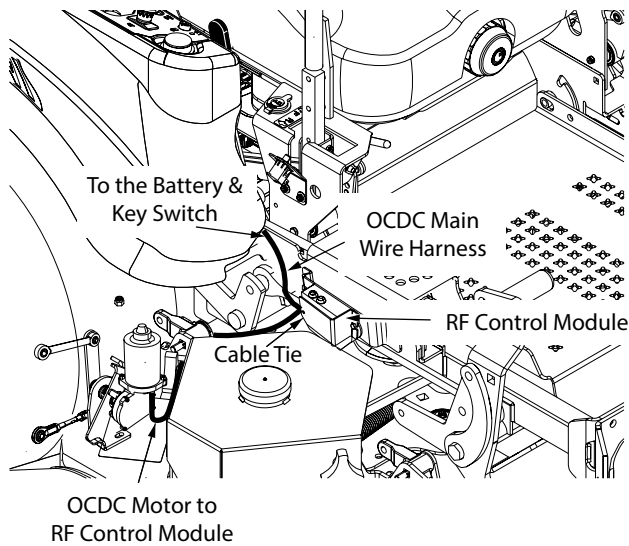

Figure 3-24. E-OCDC Wire Harness Installation

10. Remove and retain the two (2) 3/8-16 x 1 1/4" bolts, lock washers and flat washers securing the right hand drive handle to the control lever bar.
11. Remove the RH handle and retain for any future use.
12. Install the right hand drive handle included with the EOCDK kit to the control lever bar by re-using the hardware that was removed in step 11.
13. Tighten the hardware securing the handle to the control lever bar.
14. Locate the plastic pull strip preventing battery contact on the RF switch and remove it from the switch.
15. Install the RF switch into the end of the right hand drive handle. See Figure 3-23. It may be necessary to add a light application of silicone to retain the switch in the handle.

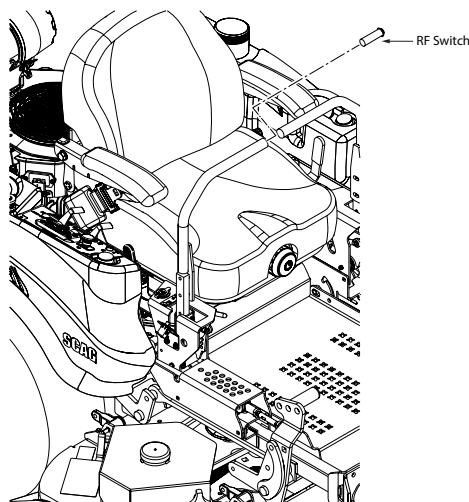

Figure 3-25. RF Switch Installation

16. Install the EOCDK discharge chute to the cutter deck. Secure using two (2) 5/16-18 x 1 3/4" bolts and two (2) 2 5/16-18 elastic stop nuts. See Figure 3-24.

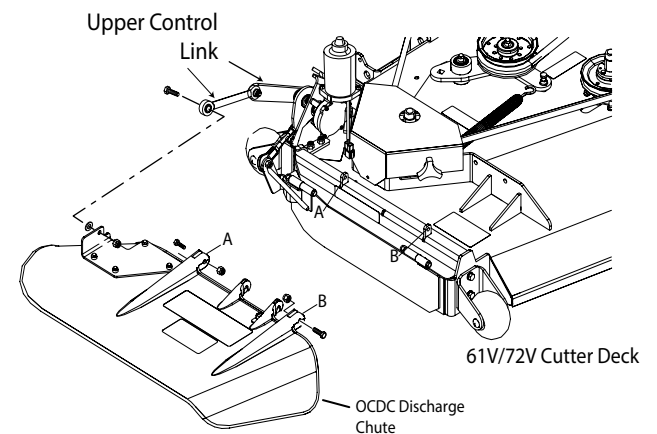
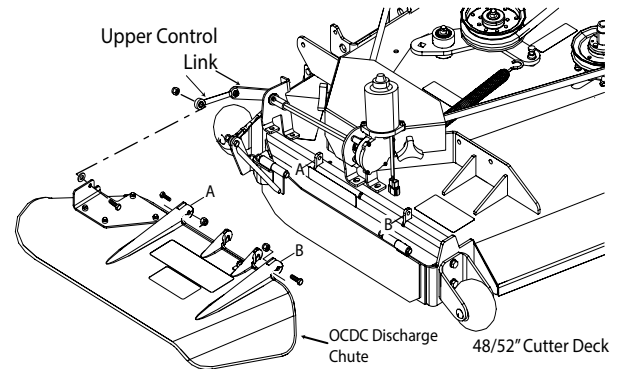

Figure 3-26. Discharge Chute Installation

17. Tighten the hardware.
18. Secure the upper control link to the E-OCDC discharge chute using one (1) 5/16-18 x 1 11/2" bolt and one (1) 5/16-18 elastic stop nut. A spacer will be required to install the 61 and 72 inch discharge chutes. See Figure 3-24.
19. Tighten the hardware.
20. Connect the E-OCDC motor wire harness to the RF control module.
21. Operate the E-OCDC checking for proper operation as outlined in Section 2.4, pages 4 and 5.
22. An adjustment may need to be made to the lower control link to ensure smooth operation.

3.5 STTII RF CONTROL MODULE AND DRIVE HANDLE INSTALLATION INSTRUCTIONS

Prepare the machine for easy and safe access to the work area. Park the machine on a flat, level surface and apply the parking brake. Remove the ignition key and disconnect the positive and negative cables from the battery. Maintain all safety related work procedures. Always wear hand and eye protection.

1. Remove and retain the two (2) 5/16-18 x 1 1/4" bolts securing the cutting height bracket to the frame. See Figure 3-25.

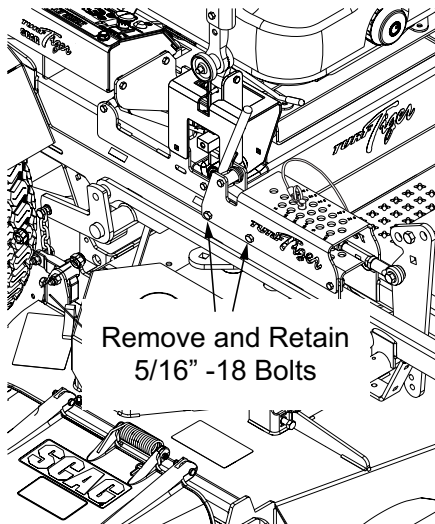

Figure 3-27. STTII Hardware Removal

2. Install the RF control module mounting bracket to the cutting height bracket using the 5/16 - 18 x 1 1/4" bolts removed in step 1. See Figure 3-25.
3. Secure the RF control module and guard to the mounting bracket using two (2) 1/4-20 x 1" bolts, two (2) 1/4" flat washers, and two (2) 1/4-20 elastic stop nuts. See Figure 3-26.

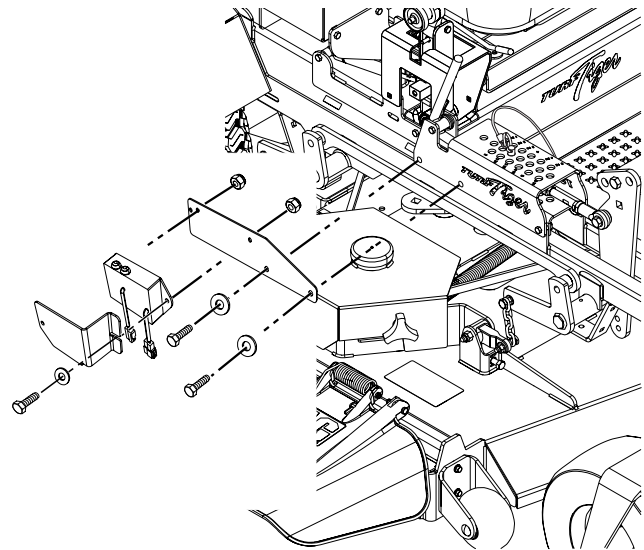

Figure 3-28. RF Module and Mounting Bracket Installation

4. Using a cable tie, retain the wires from the RF control module to the hole in the RF control module guard. See Figure 3-27.
5. Locate the "A" terminal on the key switch and install the green wire from the E-OCDC harness to the key switch. See Figure 3-27.
6. Plug the EOCD main wire harness into the RF control module. See Figure 3-27. DO NOT plug the EOCD motor harness into the RF control module at this time, this may cause movement of the linkages.
7. Route the battery leads of the E-OCDC wire harness along the frame rail on the right side of the unit towards the battery.
8. Install the wires from the EOCD harness to the battery using the red and black leads. Connect the red wire to the positive terminal first and then the black wire to the negative terminal.
9. Using the cable ties provided in the kit, secure the OCDC harness to prevent interference or damage to the harness.
10. Secure the relay on the E-OCDC harness to the main wire harness of the unit using a cable tie.

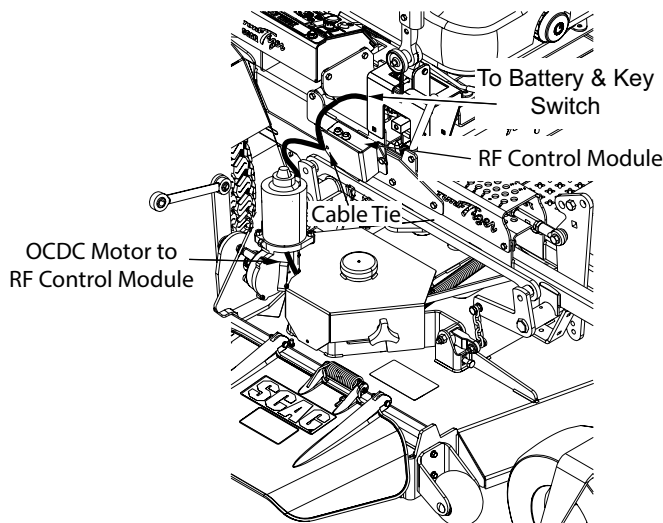

Figure 3-29. E-OCDC Wire Harness Installation

11. Remove and retain the two (2) 3/8-16 x 1 1/4" bolts, lock washers and flat washers securing the right hand drive handle to the control lever bar.
12. Remove the right hand drive handle and retain for any future use.
13. Install the right hand drive handle included with the EOCDK kit to the control lever bar by re-using the hardware that was removed in step 11.
14. Tighten the hardware securing the right hand drive handle to the control lever bar.
15. Locate the plastic strip preventing battery contact on the RF switch and remove it from the switch.
16. Install the RF switch into the end of the right hand drive handle. See Figure 3-28. It may be necessary to add a light application of silicone to retain the switch in the handle.

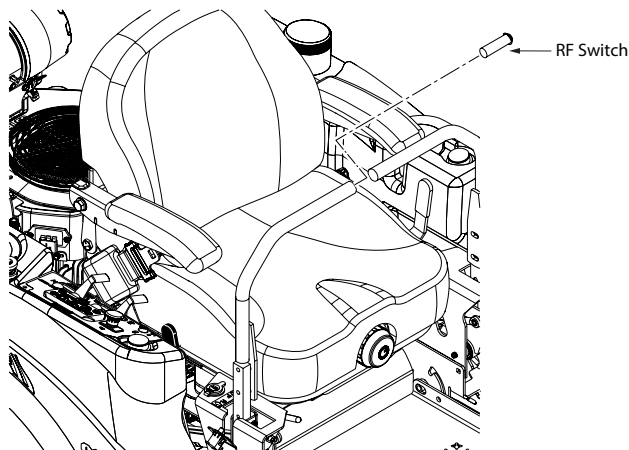

Figure 3-30. RF Switch Installation

17. Install the EOCDK discharge chute to the cutter deck. Secure using two (2) 5/16-18 x 1 3/4" bolts and two (2) 5/16-18 elastic stop nuts. See Figure 3-29.

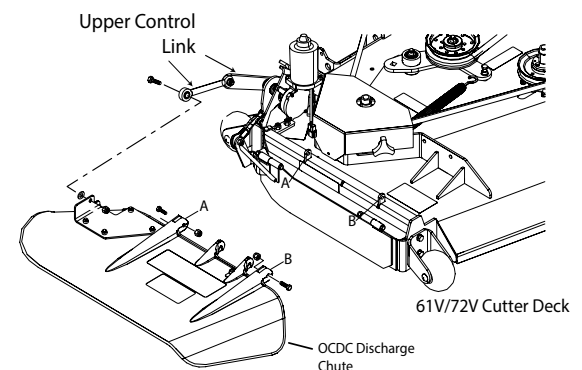
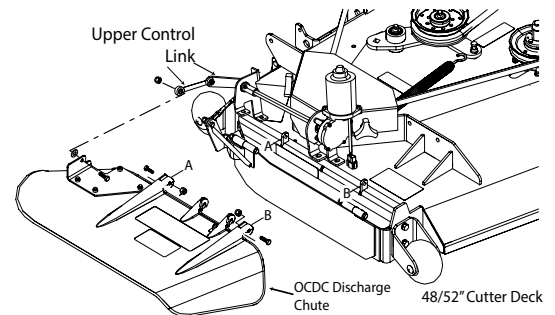

Figure 3-31. Discharge Chute Installation

18. Tighten the hardware.
19. Secure the upper control link to the EOCDK discharge chute using one (1) 5/16-18 x 1 1/4" bolt and one (1) 5/16-18 elastic stop nut. See Figure 3-29.
20. Tighten the hardware.
21. Connect the E-OCDC motor wire harness to the RF control module.
22. Operate the E-OCDC checking for proper operation as outlined in Section 2.4, pages 4 and 5.
23. An adjustment may need to be made to the lower control link to ensure smooth operation.

3.6 SVR11 RF CONTROL MODULE AND DRIVE HANDLE INSTALLATION INSTRUCTIONS

Prepare the machine for easy and safe access to the work area. Park the machine on a flat, level surface and apply the parking brake. Remove the ignition key and disconnect the positive and negative cables from the battery. Maintain all safety related work procedures. Always wear hand and eye protection.

1. Install the RF control module inner and outer mounting brackets to the frame using three (3) 1/4" - 20 x 2 1/4" bolts and three (3) 1/4" elastic stop nuts. See Figure 3-30.
2. Secure the RF control module and guard to the mounting bracket using two 1/4" - 20 x 1" bolts, two 1/4" flat washers, and two 1/4" - 20 elastic stop nuts. See Figure 3-32.

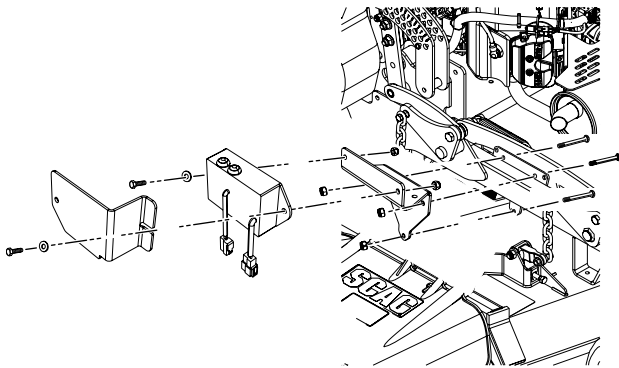

Figure 3-32. SVR11 RF Module and Mounting Bracket Installation

3. Using a cable tie, retain the wires from the RF control module to the hole in the RF control module guard. See Figure 3-31.
4. Locate the "A" terminal on the key switch and install the green wire from the E-OCDC harness to the key switch. See Figure 3-31.
5. Plug the EOCD main wire harness into the RF control module. See Figure 3-31. DO NOT plug the E-OCDC motor harness into the RF control module at this time, this may cause movement of the linkages.
6. Route the battery leads of the E-OCDC wire harness along the frame rail on the right side of the unit towards the battery.
7. Install the wires from the E-OCDC harness to the battery using the red and black leads. Connect the red wire to the positive terminal first and then the black wire to the negative terminal.

8. Using the cable ties provided in the kit, secure the EOCD harness to prevent interference or damage to the harness.
9. Secure the relay on the E-OCDC harness to the main wire harness of the unit using a cable tie.

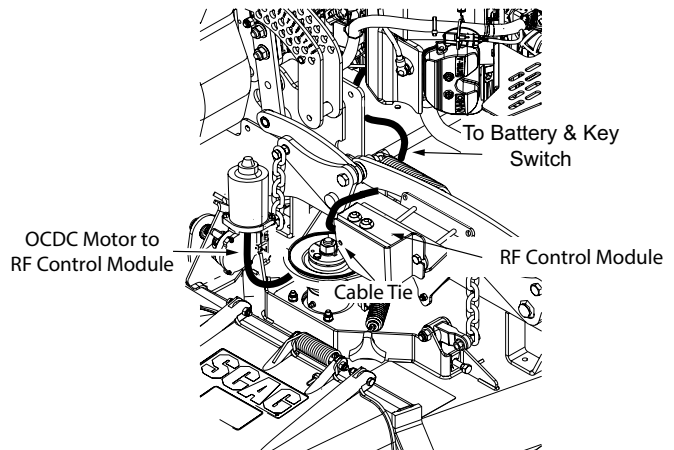

Figure 3-33. E-OCDC Wire Harness Installation

10. Remove and discard the two (2) 1/4"-20 x 3/4" tap tite screws from the front of the control panel. See Figure 3-32.

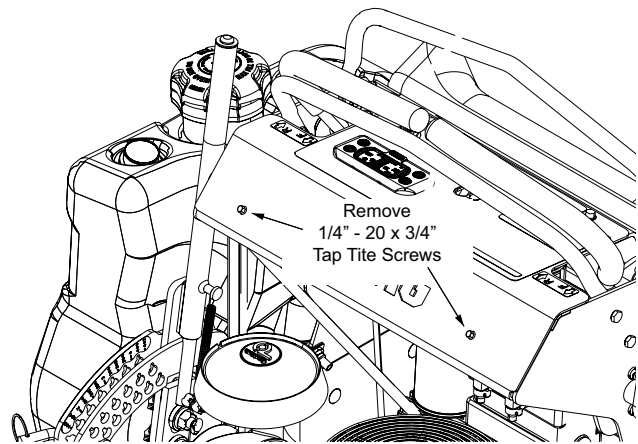

Figure 3-34. Control Panel Hardware Removal

11. Install the RF switch mounting bracket to the control panel using the two (2) 1/4" - 20 x .75" tap tite screws included in the kit. See Figure 3-33.
12. Locate the plastic pull strip preventing battery contact on the RF switch and remove it from the switch.
13. Install the RF switch into the mounting bracket as shown in Figure 3-33. It may be necessary to add a light application of silicone to the outside of the switch to retain the switch in the bracket.

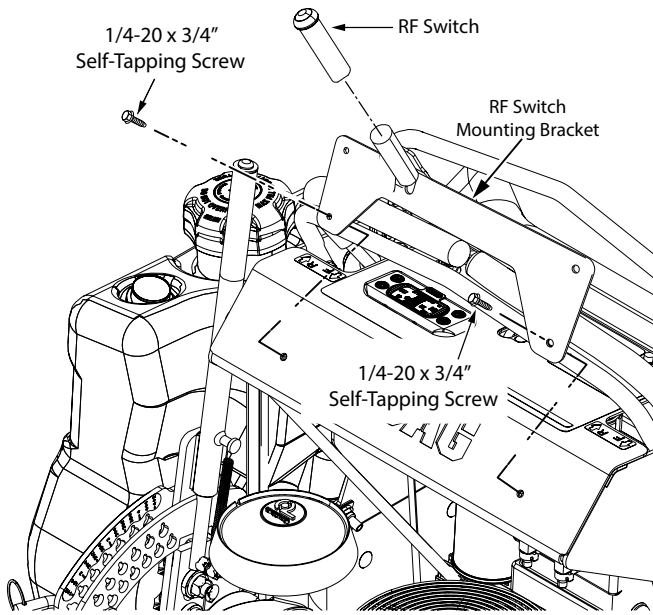

Figure 3-35. SVRII RF Switch Mounting Bracket Installation

14. Install the E-OCDC discharge chute to the cutter deck. Secure using two (2) 5/16-18 x 1-3/4" bolts and two (2) 2 5/16-18 elastic stop nuts. See Figure 3-34.

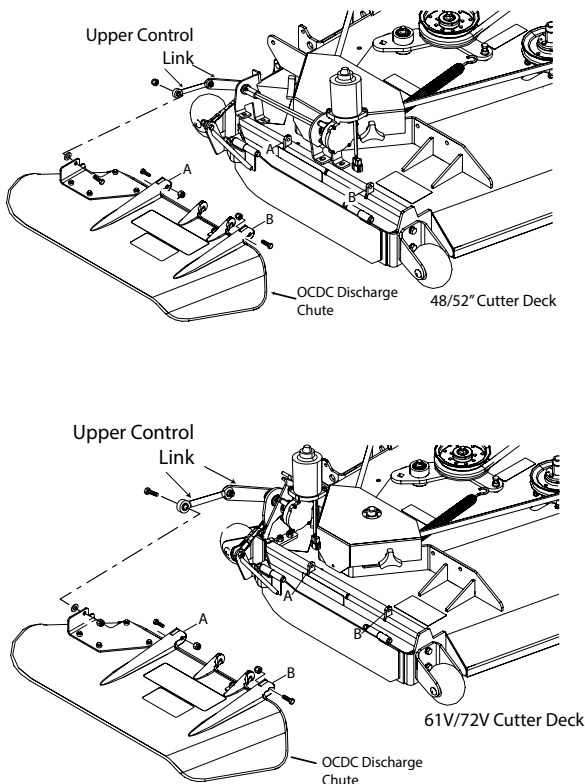

Figure 3-36. Discharge Chute Installation

15. Tighten the hardware.

16. Secure the upper control link to the OCDC discharge chute using one (1) 5/16-18 x 1-1/4" bolt and one (1) 5/16-18 elastic stop nut. See Figure 3-34.
17. Tighten the hardware.
18. Connect the E-OCDC motor wire harness to the RF control module.
19. Operate the E-OCDC checking for proper operation as outlined in Section 2.4, pages 4 and 5.
20. An adjustment may need to be made to the lower control link to ensure smooth operation.

3.7 SCZII RF CONTROL MODULE AND DRIVE HANDLE INSTALLATION INSTRUCTIONS

Prepare the machine for easy and safe access to the work area. Park the machine on a flat, level surface and apply the parking brake. Remove the ignition key and disconnect the positive and negative cables from the battery. Maintain all safety related work procedures. Always wear hand and eye protection.

1. Remove and retain the two (2) 5/16-18 x 1 1/4" bolts securing the cutting height bracket to the frame. See Figure 3-35.

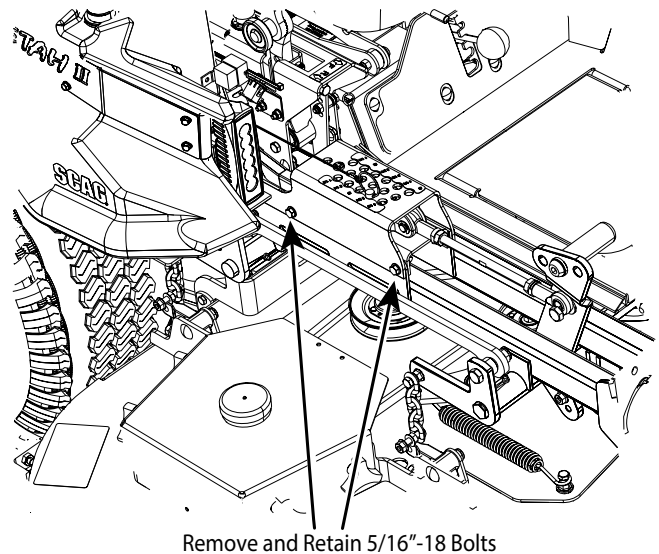

Figure 3-37. STCII Hardware Removal

2. Install the RF control module mounting bracket to the cutting height bracket using the 5/16-18 x 1 1/4" bolts removed in step 1. See Figure 3-36.

- Secure the RF control module and guard to the mounting bracket using two 1/4 - 20 x 1" bolts, two 1/4" flat washers, and two 1/4" - 20 elastic stop nuts. See Figure 3-36.

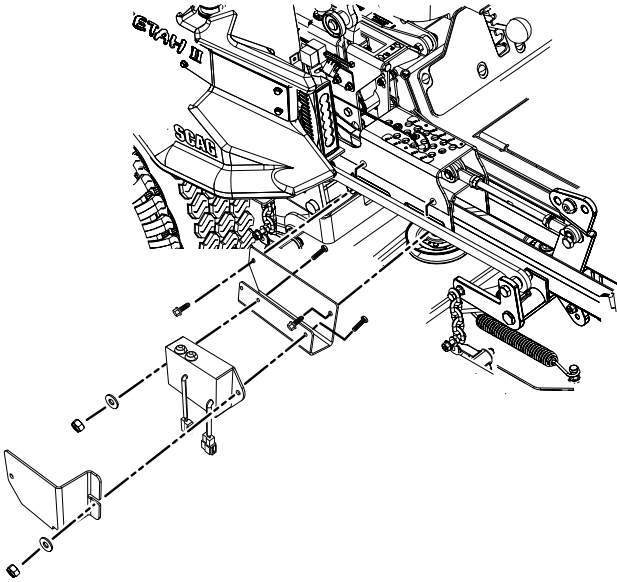

Figure 3-38. Installing SCZII RF Module Mounting Bracket

- Using a cable tie, retain the wires from the RF control module to the hole in the RF control module guard. See Figure 3-37.
- Locate the "A" terminal on the key switch and install the green wire from the E-OCDC harness to the key switch. See Figure 3-37.
- Plug the E-OCDC main wire harness into the RF control module. DO NOT plug the E-OCDC motor harness into the RF control module at this time, this may cause movement of the linkages. See Figure 3-37.
- Install the wires from the E-OCDC harness to the battery using the red and black leads. Be sure to connect the red wire to the positive terminal first and then the black wire to the negative terminal.
- Using the cable ties provided in the kit, secure the E-OCDC harness to prevent interference or damage to the harness.
- Secure the relay on the E-OCDC harness to the main wire harness of the mower using a cable tie.

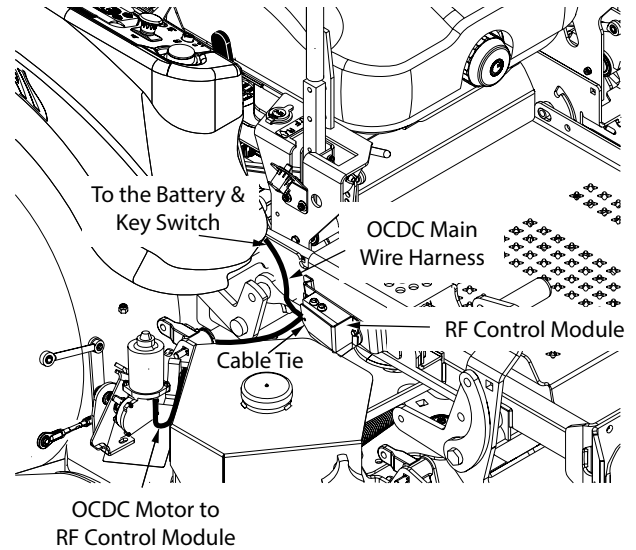

Figure 3-39. E-OCDC Wire Harness Installation

- Remove and retain the two (2) 3/8-16 x 1 1/4" bolts, lock washers and flat washers securing the right hand drive handle to the control lever bar.
- Remove the right hand drive handle and retain for any future use.
- Install the right hand drive handle included with the E-OCDC kit to the control lever bar by re-using the hardware that was removed in step 10.
- Tighten the hardware.
- Locate the plastic strip preventing battery contact on the RF switch and remove it from the switch.
- Install the RF switch into the end of the right hand drive handle. See Figure 3-38. It may be necessary to add a light application of silicone to retain the switch in the handle.

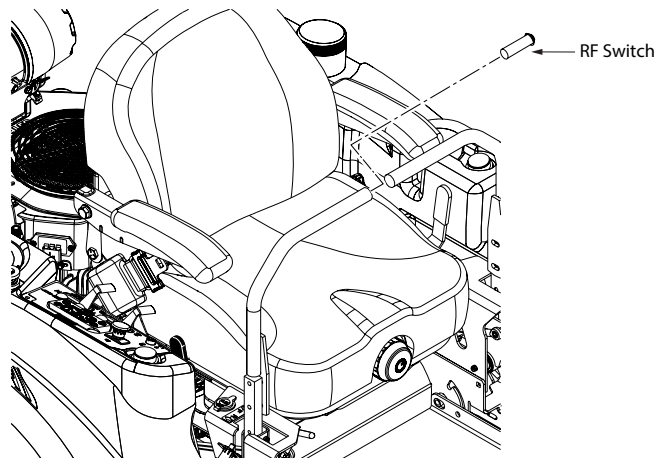

Figure 3-40. RF Switch Installation

16. Install the E-OCDC discharge chute to the cutter deck. Secure using two (2) 5/16-18 x 1-3/4" bolts and two (2) 2 5/16-18 elastic stop nuts. See Figure 3-39.

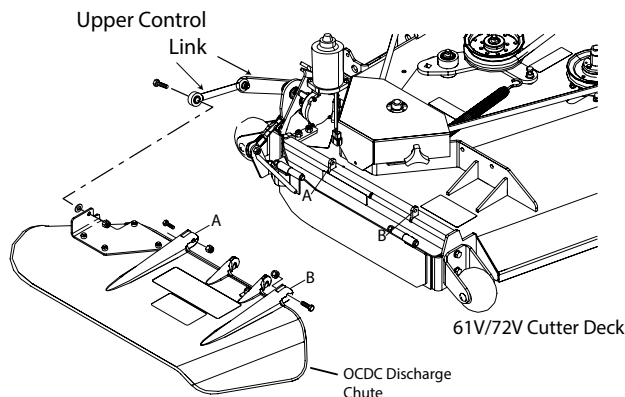
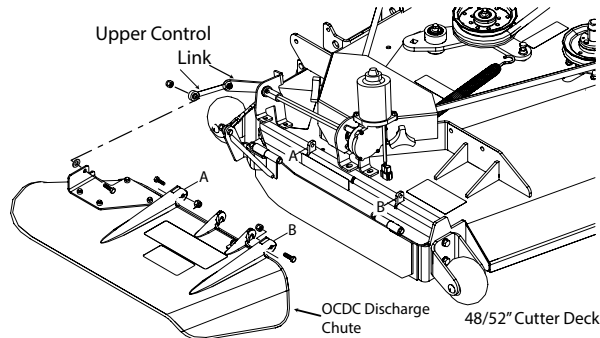

Figure 3-41. Discharge Chute Installation

17. Tighten the hardware.
18. Secure the upper control link to the E-OCDC discharge chute using one (1) 5/16-18 x 1-1/4" bolt and one (1) 5/16-18 elastic stop nut. A spacer will be required to install the 61 and 72 inch discharge chutes. See Figure 3-39.
19. Tighten the hardware.
20. Connect the E-OCDC motor wire harness to the RF control module.
21. Operate the E-OCDC checking for proper operation as outlined in Section 2.4, pages 4 and 5.
22. An adjustment may need to be made to the lower control link to ensure smooth operation.

3.8 SVRXL RF CONTROL MODULE AND DRIVE HANDLE INSTALLATION INSTRUCTIONS

Prepare the machine for easy and safe access to the work area. Park the machine on a flat, level surface and apply the parking brake. Remove the ignition key and disconnect the positive and negative cables from the battery. Maintain all safety related work procedures. Always wear hand and eye protection.

1. Remove and retain 3/8"-16 bolts from mainframe assembly; located on the side of the muffler heat shield. See Figure 3-42.

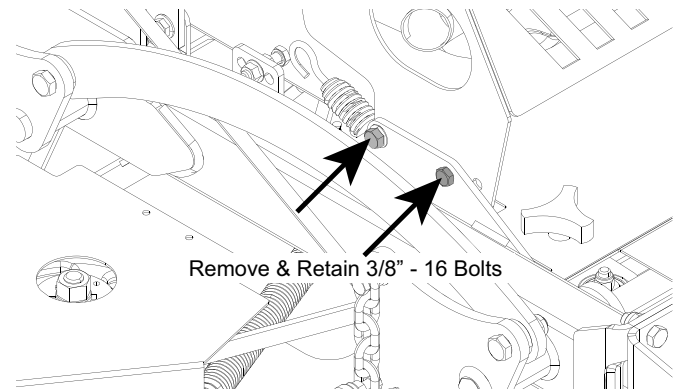

Figure 3-42. SVRXL RF Control Mount Location

2. Secure the RF control module and guard to the mounting bracket using two 1/4 - 20 x 1" bolts, two 1/4" flat washers, and two 1/4" - 20 elastic stop nuts. See Figure 3-42.

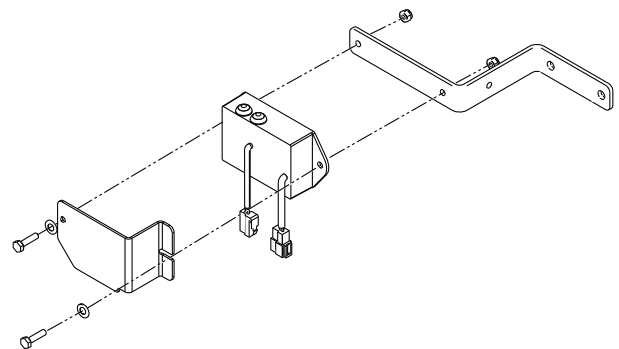

Figure 3-43. SVRXL RF Module

3. Attach RF Control Module mounting bracket to mainframe assembly. See Figure 3-44.

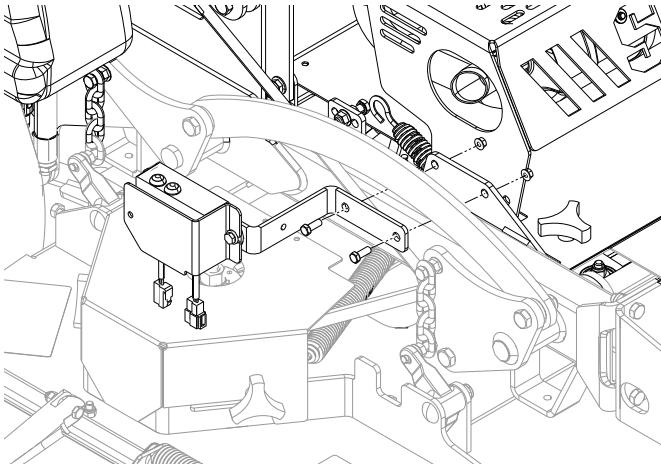

Figure 3-44. SVRXL RF Module Mount

4. Using a cable tie, retain the wires from the RF control module to the hole in the RF control module guard. See Figure 3-45.

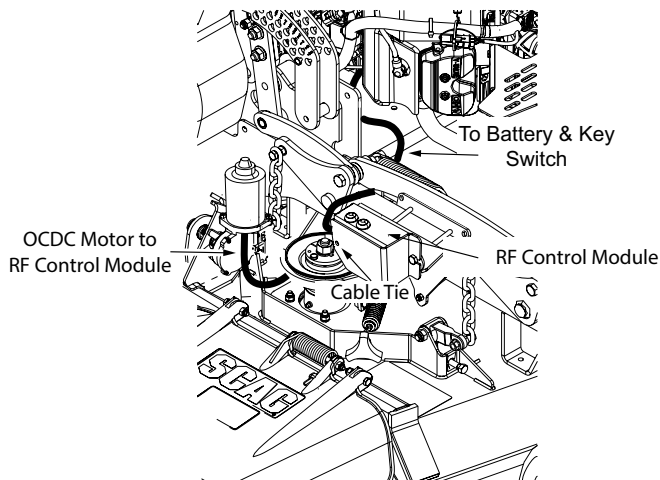

Figure 3-45. E-OCDC Wire Harness Installation

5. Locate the "A" terminal on the key switch and install the green wire from the E-OCDC harness to the key switch. See Figure 3-45.
6. Plug the EOCD main wire harness into the RF control module. See Figure 3-45. DO NOT plug the E-OCDC motor harness into the RF control module at this time, this may cause movement of the linkages.
7. Route the battery leads of the E-OCDC wire harness along the frame rail on the right side of the unit towards the battery.

8. Install the wires from the E-OCDC harness to the battery using the red and black leads. Connect the red wire to the positive terminal first and then the black wire to the negative terminal.
9. Using the cable ties provided in the kit, secure the EOCD harness to prevent interference or damage to the harness.
10. Secure the relay on the E-OCDC harness to the main wire harness of the unit using a cable tie.
11. Remove and discard the two (2) 1/4-20 x 3/4" tap tite screws from the front of the control panel. See Figure 3-46.

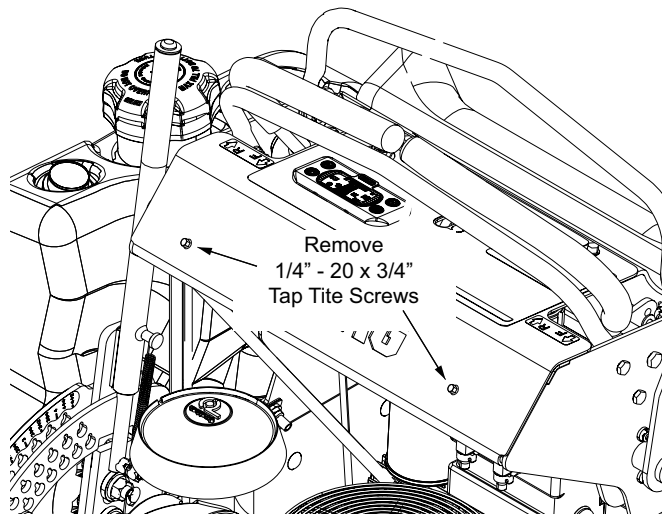

Figure 3-46. Control Panel Hardware Removal

12. Install the RF switch mounting bracket to the control panel using the two (2) 1/4" - 20 x .75" tap tite screws included in the kit. See Figure 3-47.
13. Locate the plastic pull strip preventing battery contact on the RF switch and remove it from the switch.
14. Install the RF switch into the mounting bracket as shown in Figure 3-47. It may be necessary to add a light application of silicone to the outside of the switch to retain the switch in the bracket.

Section 3

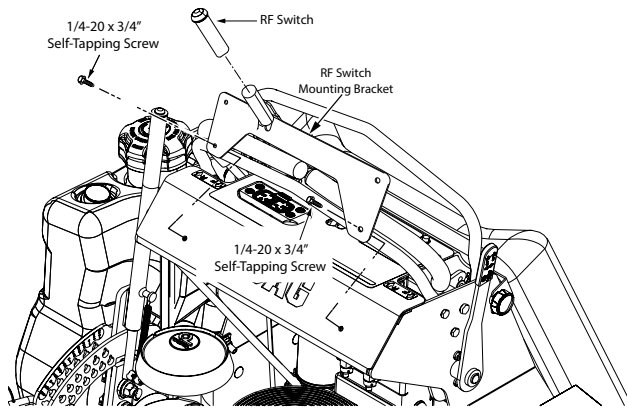

Figure 3-47. SVRXL RF Switch Mounting Bracket Installation

15. Install the E-OCDC discharge chute to the cutter deck. Secure using two (2) 5/16-18 x 1-3/4" bolts and two (2) 2 5/16-18 elastic stop nuts. See Figure 3-48.

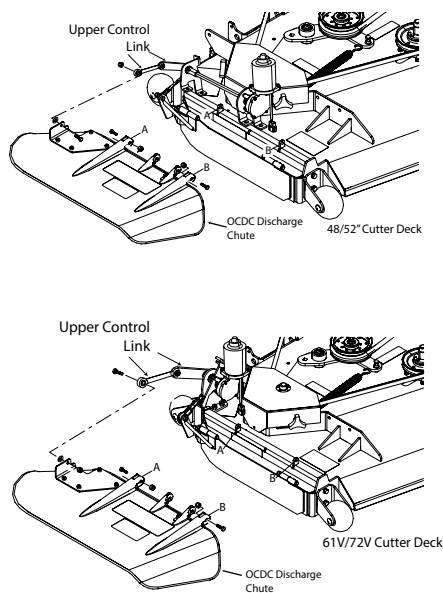

Figure 3-48. Discharge Chute Installation

16. Tighten the hardware.
17. Secure the upper control link to the OCDC discharge chute using one (1) 5/16-18 x 1-1/4" bolt and one (1) 5/16-18 elastic stop nut. See Figure 3-48.
18. Tighten the hardware.
19. Connect the E-OCDC motor wire harness to the RF control module.
20. Operate the E-OCDC checking for proper operation as outlined in Section 2.4, pages 4 and 5.
21. An adjustment may need to be made to the lower control link to ensure smooth operation.

ILLUSTRATED PARTS LIST

4.1 SCAG APPROVED ATTACHMENTS AND ACCESSORIES.

Attachments and accessories manufactured by companies other than Scag Power Equipment are not approved for use on this machine.

SVRII / STCII / STTII 48V & 52V E-OCDC

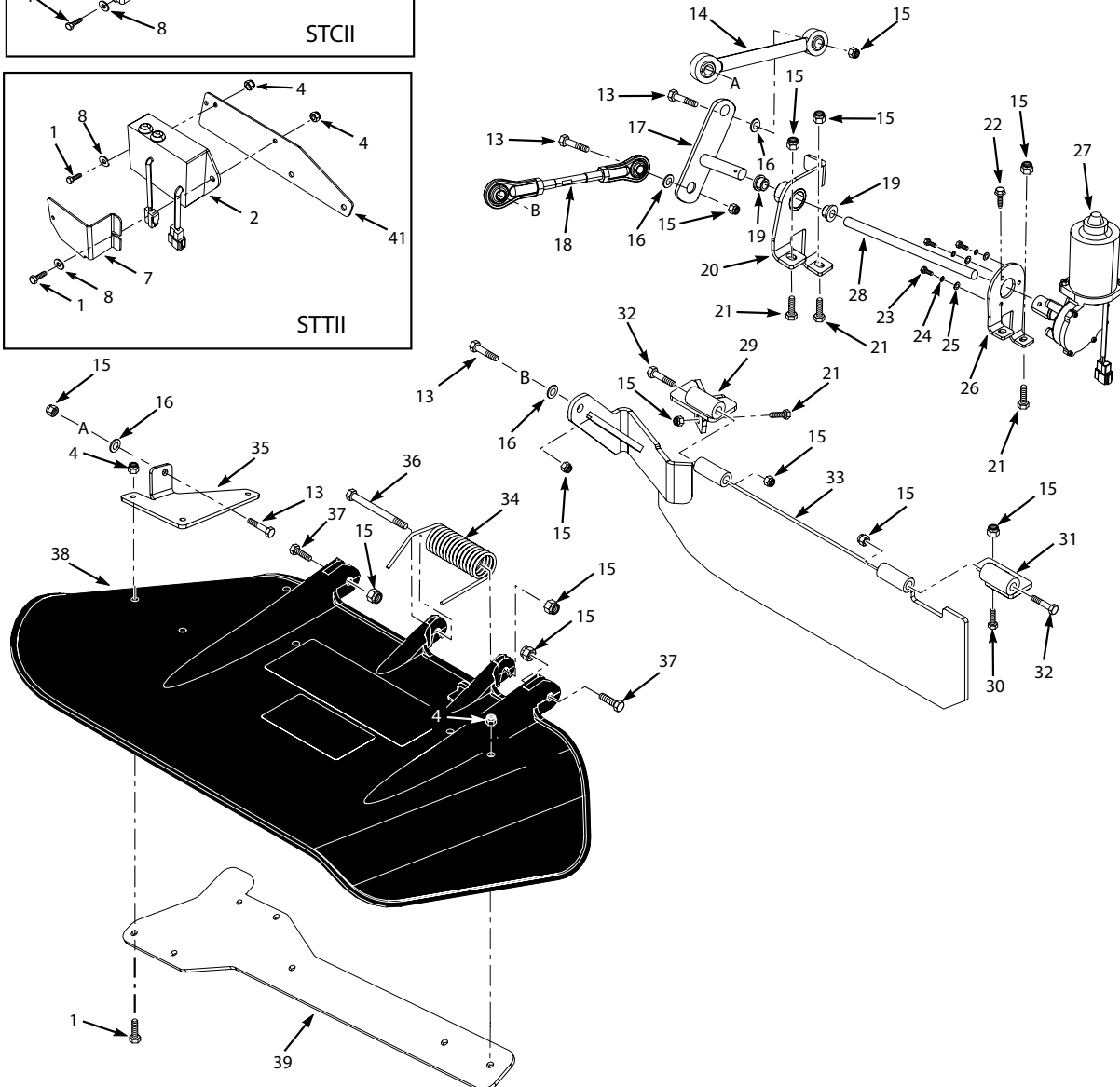
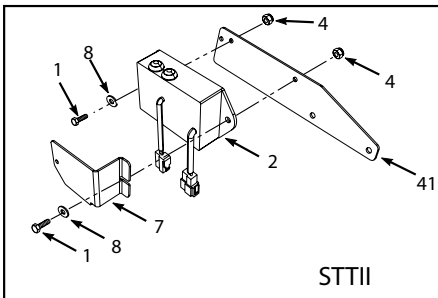
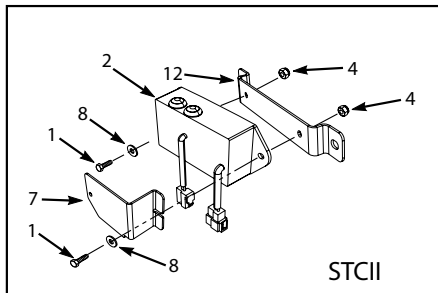
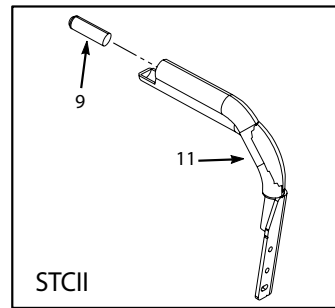
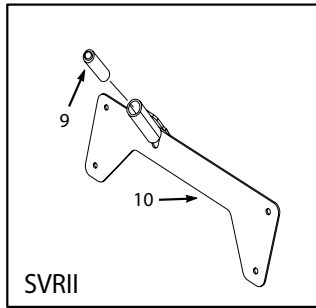
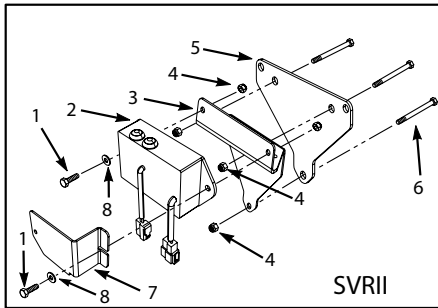

Section 4
SVRII / STCII / STTII 48V & 52V E-OCDC

Ref. No.	Part No.	Description
1	04001-14	Bolt, Hex Head 1/4 - 20 x 1"
2	486920	Module, E-OCDC (includes wire harness, Item #9)
	487169	Wire Harness, E-OCDC (only)
3	428627	Plate, Module Mtg. SVRII
4	04021-08	Nut, Elastic Stop 1/4-20
5	428628	Plate, Clamping
6	04001-199	Bolt, Hex Head 1/4 - 20 x 2.25"
7	428594	Guard, Module
8	04040-03	Washer, Flat 1/4 - .281 x .625 x .065
9	486919	Switch, RF Module E-OCDC
10	453277	Weldment, RF Switch Mtg.
11	463342	Handlebar w/ Grip, STCII
	463343	Handlebar w/ Grip, STTII
12	428599	Mounting Bracket, Module STCII
13	04001-10	Bolt, Hex Head 5/16 - 18 x 1.25"
14	486746	Linkage, Discharge Chute
15	04021-10	Nut, Elastic Stop 5/16 - 18
16	04040-15	Washer, Flat 5/16 - .375 x .875 x .083
17	453329	Weldment, Pivot Arm
18	484131	Linkage Assembly
19	483453-29	Bearing
20	453178	Weldment, Pivot Arm
21	04001-09	Bolt, Hex Head 5/16 - 18 x 1"
22	04011-07	Screw, Taptite 3/8-16 x 1.25"
23	04002-21	Bolt, M6 - 1 x 16
24	04030-02	Lockwasher, 1/4 Spring
25	04002-21	Washer, Flat 1/4 - .281 x .625 x .065
26	428404	Bracket, Motor Mtg.
27	486669	Motor, Pivot Drive
28	453220	Drive Shaft Weldment
29	452082	Rear Hinge Weldment, 48V
	452079	Rear Hinge Weldment, 52V
30	04001-08	Bolt, Hex Head 5/16 - 18 x .75"
31	452078	Front Hinge Weldment, 48V & 52V
32	04001-63	Bolt, Hex Head 5/16 - 18 x 3.50"
33	452083	Block Off Plate, 48V
	452084	Block Off Plate, 52V
34	483378	Spring, Discharge Chute
35	428393	Plate, Discharge Chute
36	04001-154	Bolt, Hex Head 5/16 - 18 x 4.75"
37	04001-12	Bolt, Hex Head 5/16 - 18 x 1.75"
38	485745	Discharge Chute, 48V
	485746	Discharge Chute, 52V
39	427141	Chute Stiffener
40	04001-01	Bolt, Hex Head 1/4 - 20 x .75"
41	428590	Bracket, Module Mtg. STTII

STCII / SCZII / STTII / SVR 61V & 72V E-OCDC

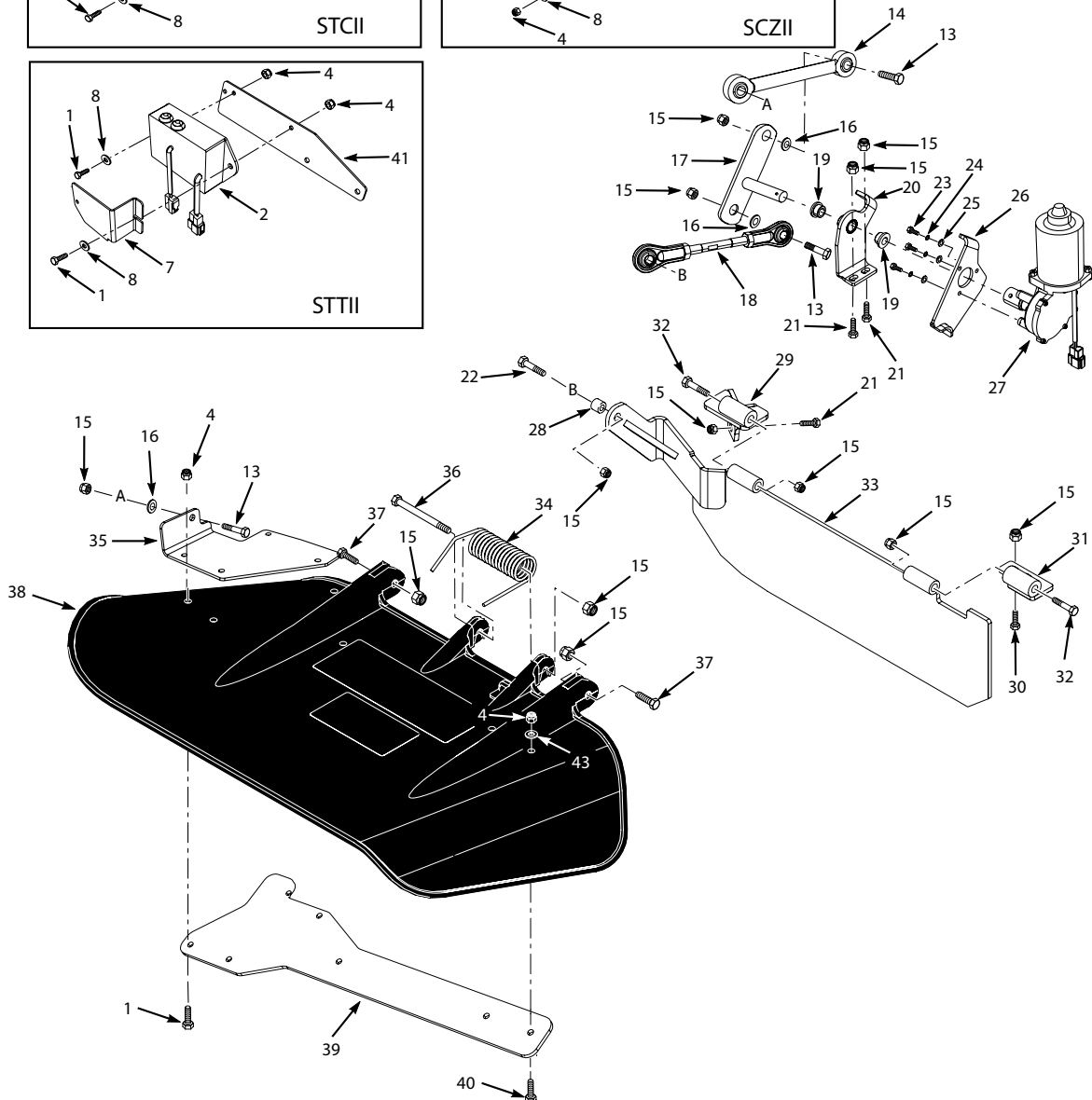
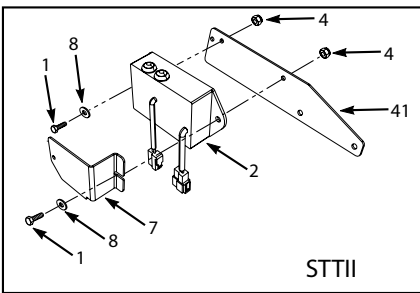
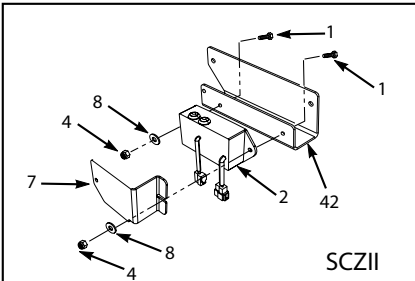
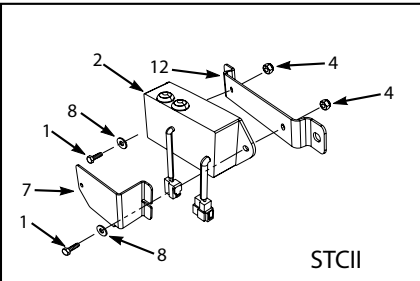
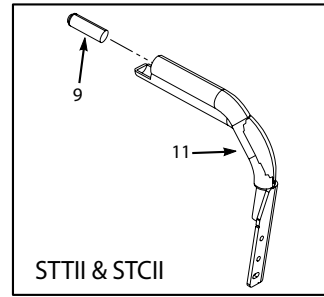
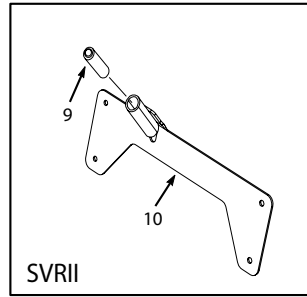
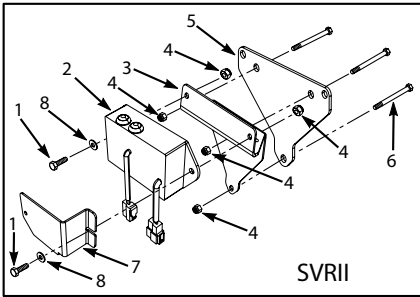

Section 4
STCII / SCZII / STTII / SVR 61V & 72V E-OCDC

Ref. No.	Part No.	Description
1	04001-14	Bolt, Hex Head 1/4 - 20 x 1"
2	486920	Module, E-OCDC (includes wire harness, Item #9)
	487169	Wire Harness, E-OCDC (only)
3	428627	Plate, Module Mtg. SVRII
4	04021-08	Nut, Elastic Stop 1/4-20
5	428628	Plate, Clamping
6	04001-199	Bolt, Hex Head 1/4 - 20 x 2.25"
7	428594	Guard, Module
8	04040-03	Washer, Flat 1/4 - .281 x .625 x .065
9	486919	Switch, RF Module E-OCDC
10	453277	Weldment, RF Switch Mtg.
11	463342	Handlebar w/ Grip, STCII
	463343	Handlebar w/ Grip, STTII, SCZII
12	428599	Mounting Bracket, Module STCII
13	04001-10	Bolt, Hex Head 5/16 - 18 x 1.25"
14	486746	Linkage, Discharge Chute
15	04021-10	Nut, Elastic Stop 5/16 - 18
16	04040-15	Washer, Flat 5/16 - .375 x .875 x .083
17	453090	Weldment, Pivot Arm
18	486661	Linkage Assembly
19	483453-29	Bearing
20	463252	Weldment, Pivot Arm (Incl. #19)
21	04001-09	Bolt, Hex Head 5/16 - 18 x 1"
22	04001-11	Bolt, Hex Head 5/16 - 18 x 1.50"
23	04002-21	Bolt, M6 - 1 x 16
24	04030-02	Lockwasher, 1/4 Spring
25	04002-21	Washer, Flat 1/4 - .281 x .625 x .065
26	453133	Bracket, Motor Mtg.
27	486669	Motor, Pivot Drive
28	43212	Spacer
29	452079	Rear Hinge Weldment, 61V
	452078	Rear Hinge Weldment, 72V
30	04001-08	Bolt, Hex Head 5/16 - 18 x .75"
31	452078	Front Hinge Weldment, 61V & 72V
32	04001-63	Bolt, Hex Head 5/16 - 18 x 3.50"
33	452080	Block Off Plate, 61V
	453328	Block Off Plate, 72V
34	483378	Spring, Discharge Chute
35	425131	Plate, Discharge Chute
36	04001-154	Bolt, Hex Head 5/16 - 18 x 4.75"
37	04001-12	Bolt, Hex Head 5/16 - 18 x 1.75"
38	487233	Discharge Chute, 61V & 72V
39	427145	Chute Stiffener
40	04001-01	Bolt, Hex Head 1/4 - 20 x .75"
41	428590	Bracket, Module Mtg. STTII
42	428595	Bracket, Module Mtg. SCZII
43	04040-14	Washer, Flat 1/4" - .312 x .750 x .065

SVRXL 52V & 72V E-OCDC

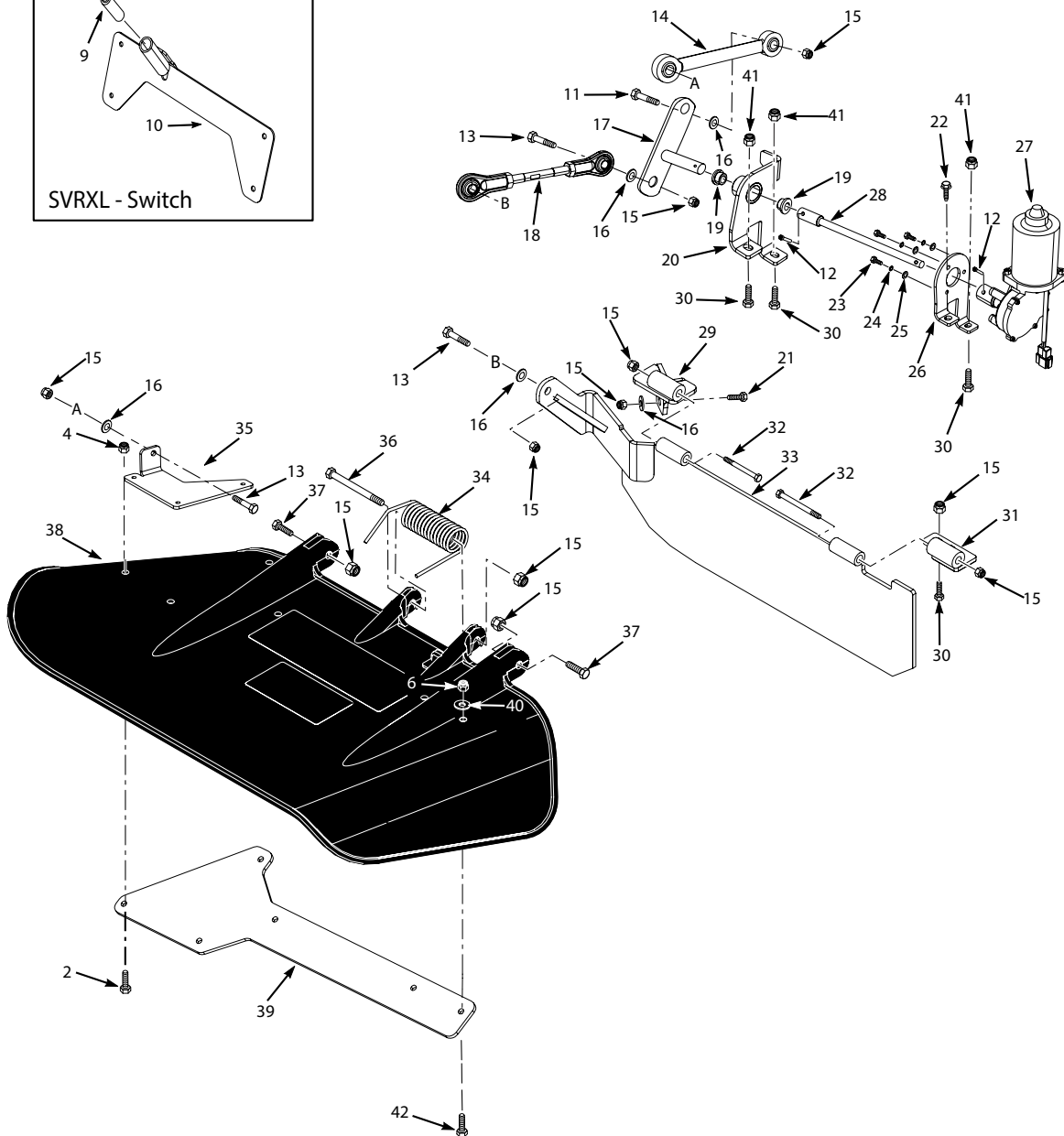
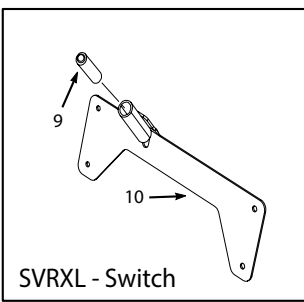
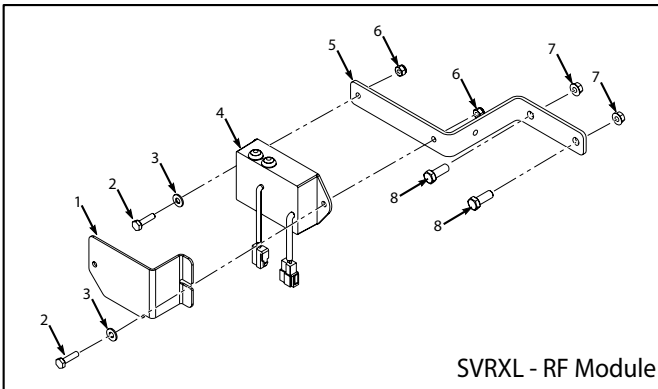

SVRXL 52V & 72V E-OCDC

Ref. No.	Part No.	Description
1	428594	Guard, Module
2	04001-14	Bolt, Hex Head 1/4 - 20 x 1"
3	04040-03	Washer, Flat 1/4 - .281 x .625 x .065
4	486850	Control Module, E-OCDC
5	429883	Bracket, Module Mounting
6	04021-08	Nut, Elastic Stop 1/4-20
7	04019-04	Nut, Serrated Flange Hex Head 7/16-14
8	04001-19	Washer, Flat 1/4 - .281 x .625 x .065
9	486919	Switch, RF Module E-OCDC
10	453277	Weldment, RF Switch Mtg.
11	04001-11	Bolt, Hex Head 5/16 - 18 x 1.50"
12	04015-43	Capscrew, Socket #10-32
13	04001-10	Bolt, Hex Head 5/16 - 18 x 1.25"
14	486746	Linkage, Discharge Chute
15	04021-10	Nut, Elastic Stop 5/16 - 18
16	04040-15	Washer, Flat 5/16 - .375 x .875 x .083
17	453329	Weldment, Pivot Arm
18	484131	Linkage Assembly
19	483453-29	Bearing
20	463286	Pivot Assembly
	453178	Weldment, Pivot Arm
21	04001-09	Bolt, Hex Head 5/16 - 18 x 1"
22	04011-07	Screw, Taptite 3/8-16 x 1.25"
23	04002-21	Bolt, M6 - 1 x 16
24	04040-02	Washer, Flat 3/16 - .25 x .562 x .049
25	04040-03	Washer, Flat 1/4 - .281 x .625 x .065
26	428404	Bracket, Motor Mtg.
27	486669	Motor, Pivot Drive
28	453220	Drive Shaft Weldment
29	452079	Rear Hinge Weldment, 52V
	452078	Rear Hinge Weldment, 72V
30	04001-08	Bolt, Hex Head 5/16 - 18 x .75"
31	452078	Front Hinge Weldment, 52V & 72V
32	04001-63	Bolt, Hex Head 5/16-18 UNC X 3.50
33	452080	Plate Weldment, Blockoff OCDC
34	483378	Spring, Discharge Chute
35	425131	Plate, Discharge Chute OCDC
36	04001-154	Bolt, Hex Head 5/16 - 18 x 4.75"
37	04001-12	Bolt, Hex Head 5/16 - 18 x 1.75"
38	487233	Discharge Chute, 72V
39	427145	Chute Stiffener
40	04040-14	Washer, Flat 1/4" - .312 x .750 x .065
41	04117-01	Locknut w/Flange Elastic Stop, 5/16-18
42	04001-01	Bolt, Hex Head 1/4 - 20 x .75"

SVRXL 61V E-OCDC

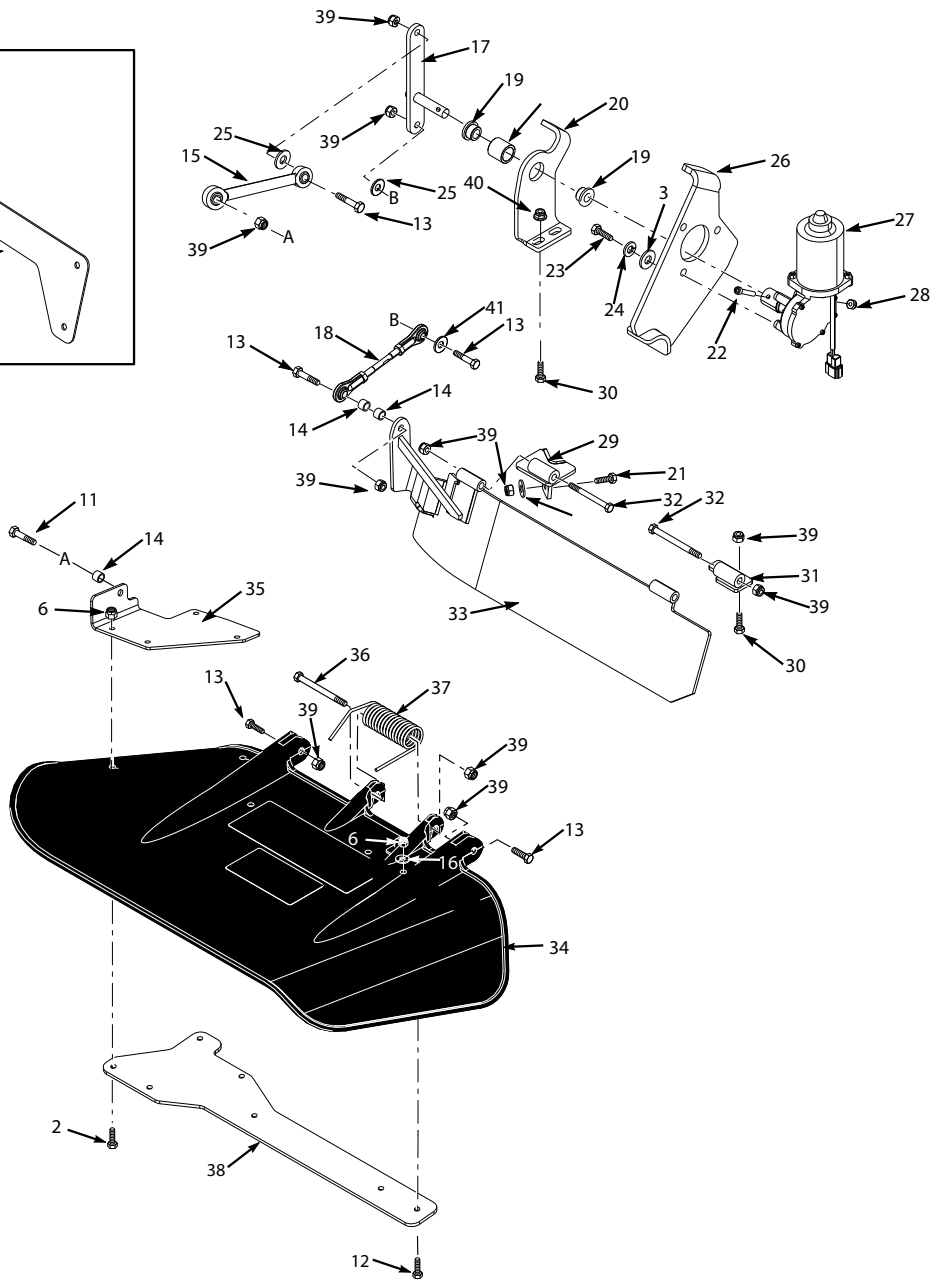
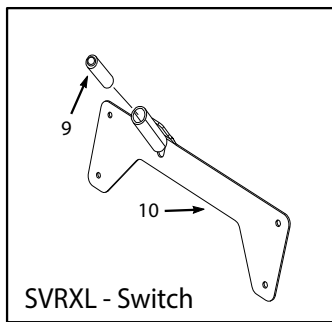
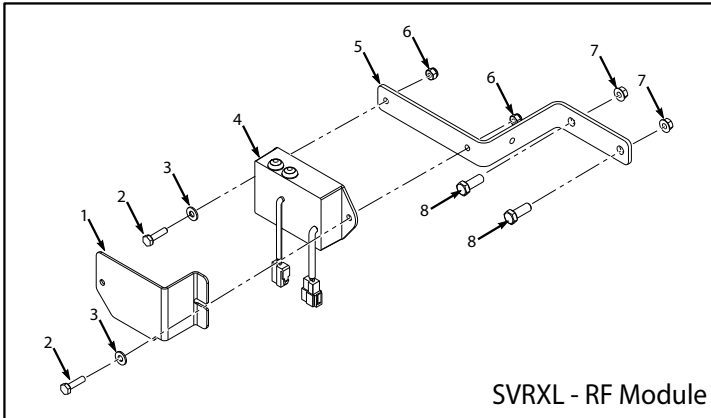

SVRXL 61V E-OCDC

Ref. No.	Part No.	Description
1	428594	Guard, Module
2	04001-14	Bolt, Hex Head 1/4 - 20 x 1"
3	04040-03	Washer, Flat 1/4 - .281 x .625 x .065
4	486850	Control Module, E-OCDC
5	429883	Bracket, Module Mounting
6	04021-08	Nut, Elastic Stop 1/4-20
7	04019-04	Nut, Serrated Flange Hex Head 7/16-14
8	04001-19	Washer, Flat 1/4 - .281 x .625 x .065
9	486919	Switch, RF Module E-OCDC
10	453277	Weldment, RF Switch Mtg.
11	04001-10	Bolt, Hex Head 5/16 - 18 x 1.25
12	04001-01	Bolt, Hex Head 1/4 - 20 x .75
13	04001-12	Bolt, Hex Head 5/16 - 18 x 1.75
14	43212	Sleeve, Hydro Linkage
15	486746	Linkage, Discharge Chute
16	04040-14	Washer, Flat 1/4" - .312 x .750 x .065
17	453090	Weldment, Pivot Arm
18	486661	Linkage Assembly
19	483453-29	Bearing
20	428118	Mounting Bracket, Pivot Arm
21	04001-09	Bolt, Hex Head 5/16 - 18 x 1
22	04015-43	Capscrew, Socket #10-32
23	04002-21	Bolt, M6 - 1 x 16
24	04030-02	Lockwasher, 1/4 Spring
25	04040-15	Washer, Flat 5/16 - .375 x .875 x .083
26	428217	Motor Mount Bracket
27	463253	Motor Mounting Assembly, E-OCDC 61V
28	04021-01	Hex Lock Nut, #10-32
29	452079	Rear Hinge Weldment, 52V
30	04001-08	Bolt, Hex Head 5/16 - 18 x .75
31	452078	Front Hinge Weldment
32	04001-63	Bolt, Hex Head 5/16 - 18 x 3.50
33	452080	Block Off Plate, 61V
34	463469	Discharge Chute Assembly, E-OCDC 61V / 72V
	487233	Discharge Chute, 61V
35	425131	Plate, Discharge Chute
36	04001-154	Bolt, Hex Head 5/16 - 18 x 4.75"
37	483378	Spring, Discharge Chute
38	427145	Chute Stiffener
39	04021-10	Nut, Elastic Stop 5/16 - 18
40	04117-01	Locknut w/Flange Elastic Stop, 5/16-18
41	04040-15	Washer, Flat 5/16 - .375 x .875 x .083

LIMITED WARRANTY- COMMERCIAL ACCESSORY

Any part of the Scag commercial accessory manufactured by Scag and found, in the reasonable judgment of Scag, to be defective in material or workmanship, will be repaired or replaced by an Authorized Scag Service Dealer without charge for parts and labor.

The Scag accessory, including any defective part, must be returned to an Authorized Scag Service Dealer within the warranty period. The expense of delivering the accessory to the dealer for warranty work and the expense of returning it back to the owner after repair or replacement will be paid for by the owner. Scag's responsibility in respect to claims is limited to making the required repairs or replacements, and no claim of breach of warranty shall be cause for cancellation or rescission of the contract of sale of any Scag machine. Proof of purchase will be required by the dealer to substantiate any warranty claim. All warranty work must be performed by an Authorized Scag Service Dealer.

This warranty is limited to 90 days from the date of original retail purchase for any Scag accessory that is used for commercial purposes, or any other income-producing purpose including rental use.

This warranty does not cover any accessory that has been subject to misuse, neglect, negligence, or accident, or that has been operated in any way contrary to the operating instructions as specified in the Operator's Manual. The warranty does not apply to any damage to the accessory that is the result of improper maintenance, or to any accessory or parts that have not been assembled or installed as specified in the Operator's Manual.

The warranty does not cover any accessory that has been altered or modified. In addition, the warranty does not extend to repairs made necessary by normal wear, or by the use of parts or accessories which, in the reasonable judgment of Scag, are either incompatible with the Scag mower or adversely affect its operation, performance or durability. This warranty does not cover engines and electric starters, which are warranted separately by their manufacturer.

Scag Power Equipment reserves the right to change or improve the design of any accessory without assuming any obligation to modify any accessory previously manufactured.

All other implied warranties are limited in duration to the 90 day warranty period. Accordingly, any such implied warranties including merchantability, fitness for a particular purpose, or otherwise, are disclaimed in their entirety after the expiration of the appropriate ninety day warranty period. Scag's obligation under this warranty is strictly and exclusively limited to the repair or replacement of defective parts and Scag does not assume or authorize anyone to assume for them any other obligation. Some states do not allow limitations on how long an implied warranty lasts, so the above limitation may not apply to you.

Scag assumes no responsibility for incidental, consequential or other damages including, but not limited to, expense for gasoline, oil, expense of delivering the machine to an Authorized Scag Service Dealer and expense of returning it back to the owner, mechanic's travel time, telephone or telegram charges, rental of a like product during the time warranty repairs are being performed, travel, loss or damage to personal property, loss of revenue, loss of use of the mower, loss of time, or inconvenience. Some states do not allow the exclusion or limitation of incidental or consequential damages, so the above limitation or exclusion may not apply to you.

This warranty gives you specific legal rights, and you may also have other rights which vary from state to state.

