



SERVICE INFORMATION SHEET 219

SI 219 - July, 2022

V-Ride II (SVRII) 48V & 52V Front Caster Bolt

We have received reports from the field of the threads on front caster axle bolts not engaging with the elastic insert provided in the locking nuts on a limited number of SVRII-48V & 52V machines in the serial number ranges listed below.

<u>Model</u>	<u>Serial Range</u>
SVRII-48V-22FX	S4100001 - S4101425
SVRII-52V-26FT-EFI	S4300001 - S4300745
SVRII-52V-37BV-EFI	S4400001 - S4400220

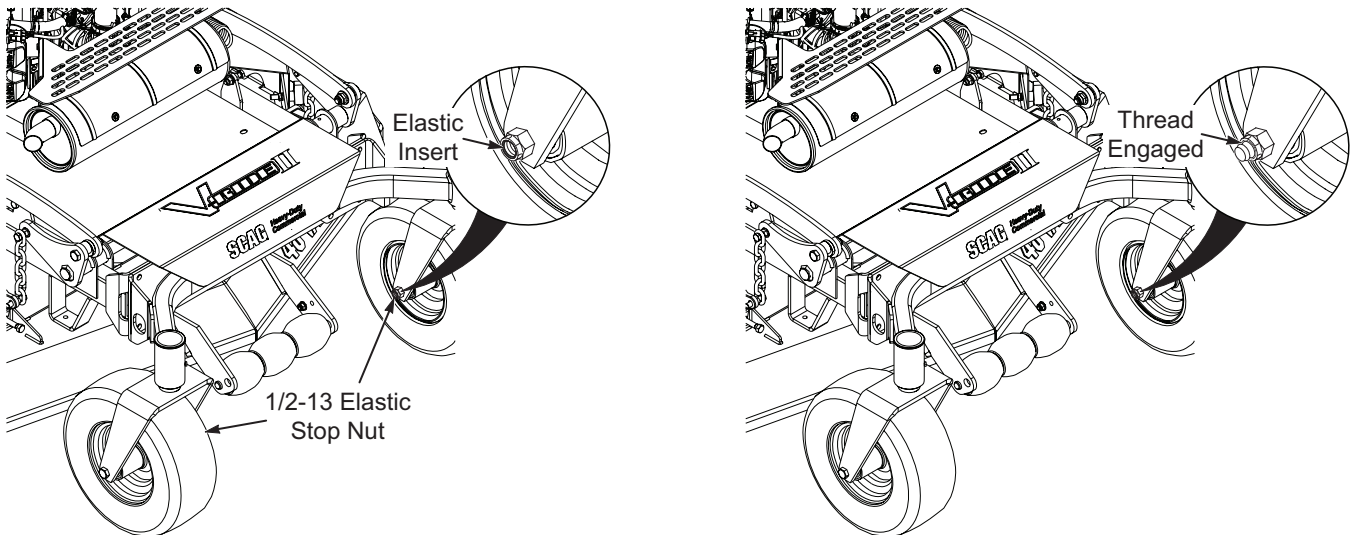

Figure 1. Front Axle Caster Bolt & Elastic Locking Nut

This can be resolved by replacement of the caster axle bolts with 1/2-13 x 8" hex head bolt p/n 04001-227.

Please contact your distributor for further assistance if needed.