

WALKER MOWERS

ILLUSTRATED PARTS MANUAL

Model MBS29



Beginning S/N: 115338
Effective Date: 07-19-12
P/N 2000-6

KEY TO ABBREVIATIONS USED IN THIS MANUAL

<i>Abbreviation</i>	<i>What it Represents</i>
° (Dimension)	Degrees (Angle)
" (Dimension)	inches
(-)	Negative (Polarity)
(+)	Positive (Polarity)
AT	All-Terrain
CCW	Counter-clockwise
Conn	Connector
CW	Clockwise
D	Diameter
DGHS	Deck, Grass Handling System (number refers to size in inches)
DML	Deck, Mulching (number refers to size in inches)
DSD	Deck, Side Discharge (number refers to size in inches)
DU	Garlock (Bearing)
ESNA (Fastener)	Nylon Insert Locknut
FSC	Forward Speed Control
GA	Gauge
gal	gallon
GHS	Grass Handling System
GR (Fastener)	Grade
HP	Horse Power
HT	Heat-Treated
ID	Identification or Inside Diameter
L	Length
LH	Left Hand (orientated with operator on seat)
LP	Low Profile
mm (Dimension)	millimeters
MS (Fastener)	Machine Screw
NS (as part number)	Item is not sold by Walker Manufacturing
OD	Outside Diameter
oz	ounce
PFH (Fastener)	Phillips Flat Head
P/N	Part Number
PPH (Fastener)	Phillips Pan Head
PTH (Fastener)	Phillips Truss Head
PTO	Power Take-Off
QKS	Quick Slide
qt	quart
RH	Right Hand (orientated with operator on seat)
SAE (Fastener)	Society of Automotive Engineers
SBH (Fastener)	Socket Button Head (Bolt)
SD	Side Discharge
SFH (Fastener)	Slotted Flat Head
SHC (Fastener)	Socket Head Cap
SHL (Fastener)	Shoulder (Bolt)
SM (Fastener)	Sheet Metal (Screw)
S/N	Serial Number
Spg	Spring
SQH (Fastener)	Square Head
SS (Fastener)	Stainless Steel
ST (Fastener)	Self-Tapping (Screw)
Term	Terminal
V	Volts

NOTE: In some instances, combinations of abbreviations may be used (e.g. PPHMS - Phillips Pan Head Machine Screw).

ILLUSTRATED PARTS LIST

<i>Section of Mower Covered</i>	<i>Page</i>	<i>Section of Mower Covered</i>	<i>Page</i>
<hr/>		<hr/>	
Decals		Electrical Components	
Tractor Decals	2	Electrical Assembly	14
Body / Chassis Assemblies		Maintenance	
Body / Chassis Assembly	4	Lubrication Points	16
Tractor Components		Wiring Schematic.....	18
Main Component Power Transmission	6	Operator's Notes	19
Engine Group.....	8	Warranty	
Hydrostatic Ground Drive Assemblies.....	10	Limited Warranty	21
Steering Control Assemblies.....	12		

TRACTOR DECALS

ITEM NO.	PART NO.	DESCRIPTION	LOCATION	NO. REQ'D SD
Walker Product and Operation Decals				
1	2802-4	RH Fender	Body, RH near Seat	1
2	5800-6	Decal, Walker 6-3/4"	Rear Body (one on each side)	2
3	2010-17	Fuel Transfer	Transfer Mount, LH	1
4	2802-5	LH Fender	Body, LH near Seat	1
5	9804-1	Axle Lockout	Hydro Mount Plate	2
6	2351-8	Decal, Belt Tensioner	Hydro Mount Plate	1
7	5856	Made in USA	Body	1
8	5803	Walker Manufacturing Logo	Body	1
Danger Decals Warning Decals Caution Decals				
9	8600-5	Caution, Engine Exhaust	Rear Body	1
10	5844-2	Warning, Electric System	Battery Hold-Down Bar	1
11	8600-12	Danger, Engine Exhaust	Engine, LH Side	1
12	2107-4	Decal, Belt Routing	Rear Body, Underside	1
13	8600-2	Danger, Rotating Components	Air Cleaner Bracket	1
Maintenance Decals				
14	5082-5	Fuel Recommendations	Rear Body (one on each side)	2
15	2105-10	RH Decal, 29 HP	Rear Body, RH Side	1
16	2105-11	LH Decal, 29 HP	Rear Body, LH Side	1
17	5855	Important, Engine Cooling	Engine	1
18	2807-2	Decal, Systems Warning	Body	1
Option Decals (applied only to units with corresponding Options installed)				
19	5877	Lights, On-Off	Body	1

NOTE: All parts requiring decals are shipped with decals applied.

TRACTOR DECALS

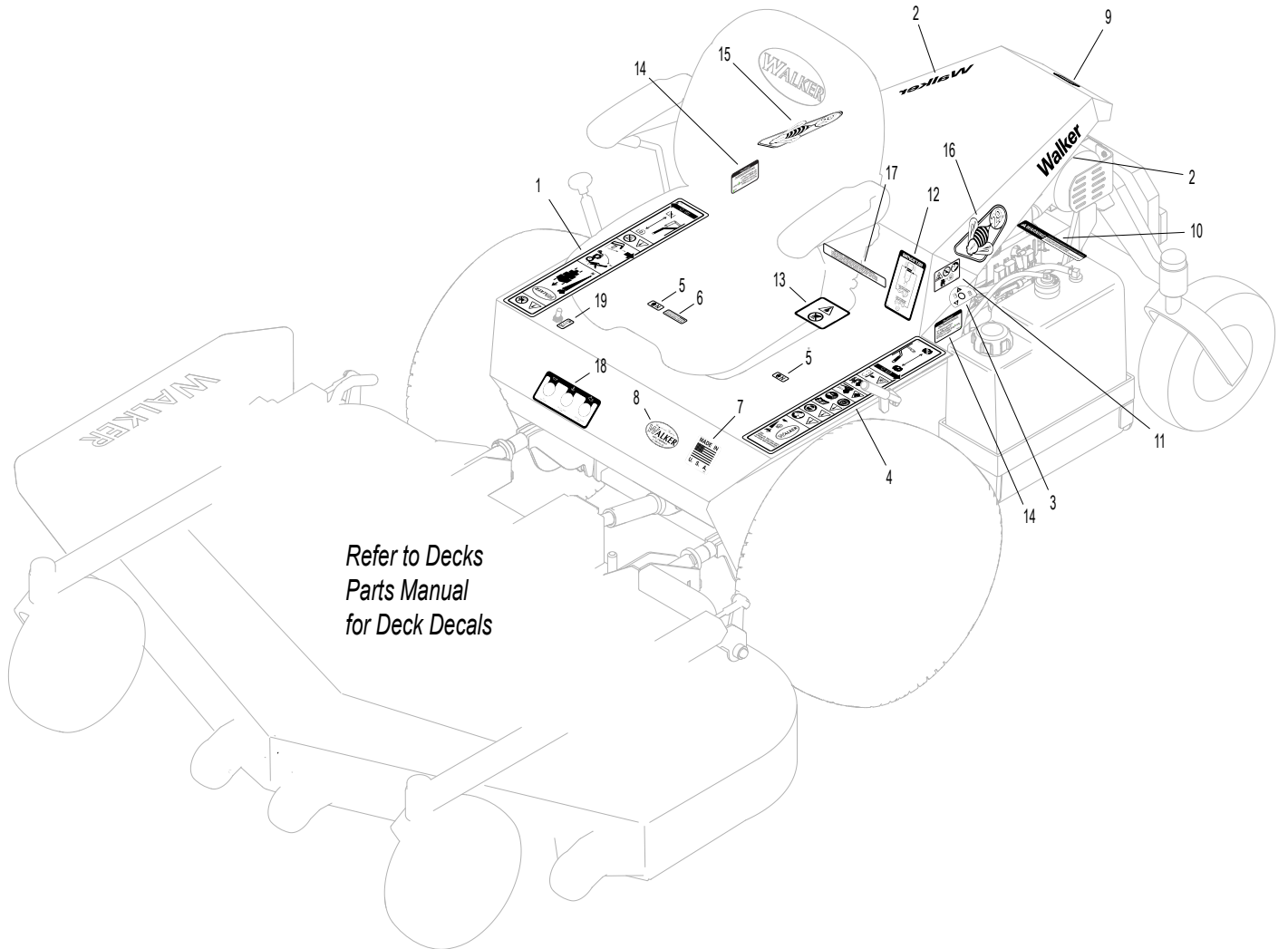

BODY / CHASSIS ASSEMBLY

ITEM NO.	PART NO.	DESCRIPTION	NO. REQ'D	ITEM NO.	PART NO.	DESCRIPTION	NO. REQ'D
Body & Seat Assembly				Deck Support Arm & Hitch Assemblies			
1	2103-1	Seat	1	44	2300-9	Deck Arm Support Mount	1
2	2105-12	Rear Body (Includes Item # 3)	1	45	6840-1	Support Arm Bushing (2-1/16)	2
3	2190-1	Insulation Foam Pad	1	46	2775	Lynch Pin (5/16 x 1-1/4)	2
4	4102-1	Body Guide, Upper	1	47	2431	Deck Support Arm, LH (Includes Item # 26)	1
5	7844	Rubber Bumper (1.25 x .250)	2	48	2430	Deck Support Arm, RH (Includes Item # 26)	1
6	5146	10mm Ball Stud	2	Tilt-Up Latch Assembly*			
7	2145	Gas Spring	1	49	5847	Plastic Tip	1
8	5180	Edge Molding, Lever Opening	2	50	5744-20	Spring Arm, Tilt-Up Latch	1
9	2100-3	Front Body Doubler	1	51	5744-10	Spring Pivot Bushing	1
10	2504-4	Hinge (22.5)	1	52	5744-15	Compression Spring (3/8 x 5/8)	1
11	2100-2	Front Body	1	53	5744-13	Mount Angle, LH	1
12	5989-5	Dome Plug (7/16)	1	54	5744-12	Hook, Tilt-Up Latch	1
13	7854	Plastic Tip, Red	1	55	5744-14	Mount Angle, RH	1
14	2383	Body Latch Hook	1	Fasteners			
15	7222	Extension Spring (1/4 x 3)	1	F002	10-24 Keps Nut		5
16	5989-4	Dome Plug (3/8)	2	F004	1/4-20 Keps Nut		18
17	5989-3	Dome Plug (5/16)	2	F005	1/4-20 ESNA Nut		2
Chassis Assembly				F009	5/16-18 Whiz Locknut		18
18	2010-12	Flex Coupling Guard, RH	1	F013	3/8-16 Whiz Locknut		2
19	2010-13	Flex Coupling Guard, LH	1	F020	5/16-18 ESNA Nut		1
20	2390-1	Battery Pan	1	F025	10-24 x 3/8 PPHMS		5
21	2046-1	Gas Tank Mount, LH	1	F029	1/4-20 x 1/2 Hex Bolt		4
22	2300-3	Chassis Frame	1	F031	1/4-20 x 5/8 Hex Bolt		2
23	2046	Gas Tank Mount	1	F034	5/16-18 x 3/4 Hex Bolt		10
24	4102-2	Body Guide, Lower	1	F050	1/4 SAE Washer		1
25	2325-8	Belt Guide	1	F093	5/16-18 x 1 Hex Bolt		1
Tail Wheel Assembly				F151	3/8-16 x 7/8 Hex Bolt		2
26	5830	Grease Fitting	4	F183	.312 x .700 x .074 Washer		4
27	2201-2	Fiberglide Thrust Washer	2	F205	5/16-18 x 1/4 Set Screw (Knurl Point)		2
28	2201-3	Fiberglide Bearing (1-5/8)	2	F218	7/16 Split Lock Washer		5
29	2300-6	Tail Wheel Pivot (Includes Items # 26 & 30)	1	F219	7/16-14 x 1-1/4 Hex Bolt		5
30	5830-3	Grease Fitting (45 Deg.)	1	F236	1/4-20 x 1-3/4 Hex Bolt		2
31	2201-4	Washer (2-1/4 x 7/16 x 1/4 Thk)	1	F246	1/4-20 x 1/2 PTHMS		5
32	8769-8	Dust Cap, Deck Caster	2	F256	7/16 SAE Washer		1
33	8769-6	Bearing Cone (1" ID)	4	F341	Coil Roll Pin (7/64 x 9/16)		1
34	8769-5	Bearing Cup (2 x 1-5/8)	4	F342	5/16 Conical Washer		2
35	8769-7	Seal	2	F344	3/4-16 Slotted Hex Nut		2
36	2770	Caster Wheel Fork	2	F347	3/4 SAE Washer		2
37	8039	Nut, Tail Wheel Axle	2	F348	1/8 x 1-1/2 Cotter Pin		2
38	8038-1	Spacer, Tail Wheel Axle (.750 x ID x 1.125 OD)	2	F430	7/16-20 ESNA Nut		2
39	8768-2	Seal, Reverse Lip	2	F442	1/4-20 x 5/8 PTHMS		5
40	8037	Bearing Cone (3/4 ID)	4	F446	7/16-20 x 3-1/2 Grd 8 Bolt		2
41	8035	Tail Wheel & Tire (13 x 5.00-6) (W/Bearing Race)	2	F477	1/4-20 x 5/8 Carriage Bolt		2
42	8037-1	Seal, Outer (1-3/4 x 1-1/8)	2	* Complete Tilt-Up Latch Assembly Kit available by ordering kit # 5747.			
43	7038	Tail Wheel Axle (3/4 x 5-9/16)	2				

Beginning S/N 115338

Effective Date 07-19-12

Use only genuine Walker® replacement parts.

BODY / CHASSIS ASSEMBLY

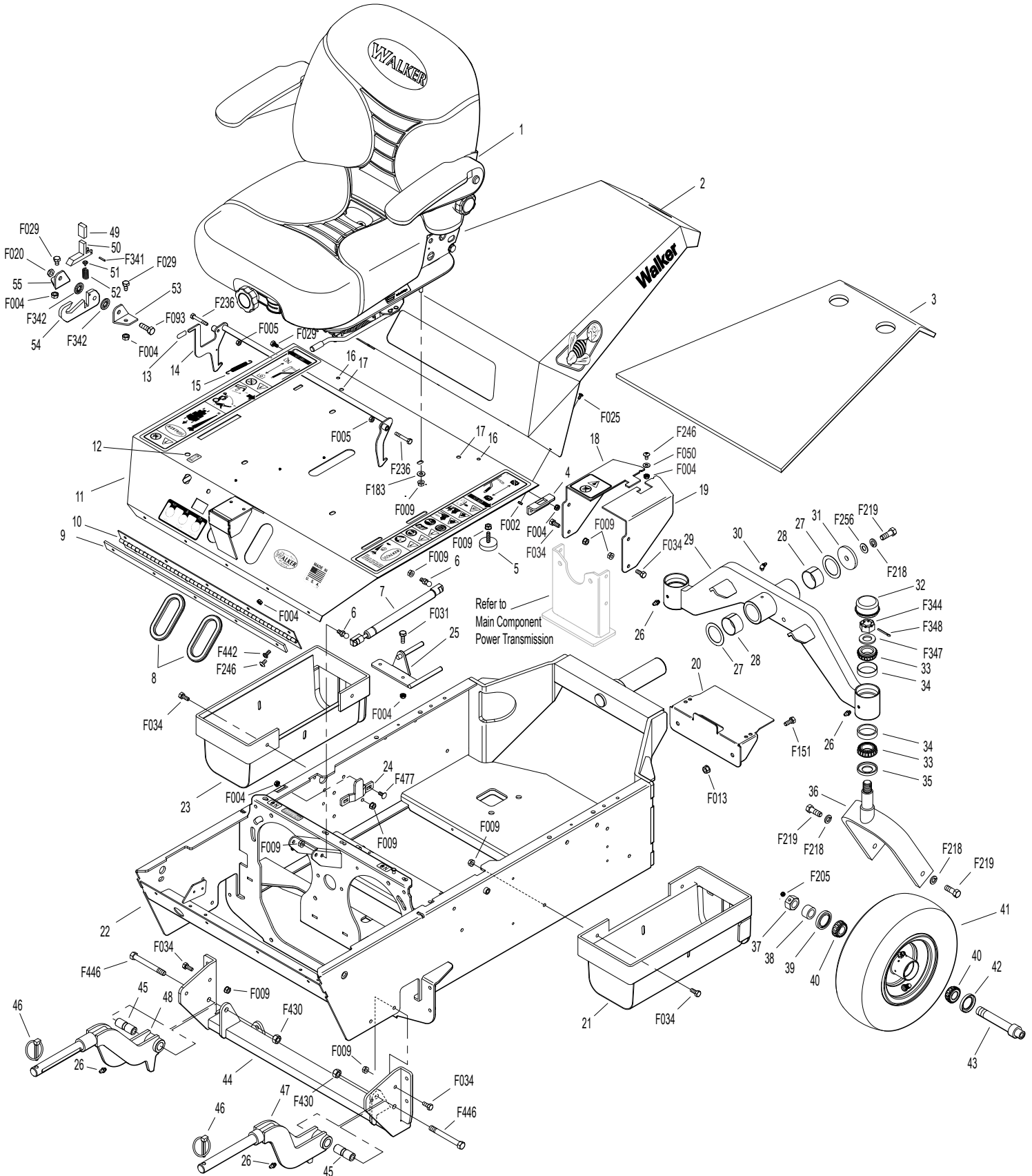

Beginning S/N 115338
 Effective Date 07-19-12
 Use only genuine Walker® replacement parts.

MAIN COMPONENT POWER TRANSMISSION

ITEM NO.	PART NO.	DESCRIPTION	NO. REQ'D	ITEM NO.	PART NO.	DESCRIPTION	NO. REQ'D
PTO Drive Assembly				Fasteners			
1	4850	Handle Grip, Black	1	F004		1/4-20 Keps Nut	5
2	2358-1	Clutch Lever, MBS (Includes Items # 1 & 3)	1	F008		5/16-24 Keps Nut	1
3	5830-3	Grease Fitting (45 Deg.)	3	F009		5/16-18 Whiz Locknut	15
4	4303-7	Clutch Actuator Bolt (5/16)	1	F010		5/16-24 ESNA Nut	1
5	2306-2	Oilite Flanged Bushing	2	F012		3/8-16 Keps Nut	1
6	5830	Grease Fitting	1	F013		3/8-16 Whiz Locknut	3
7	2325-7	Clutch Arm (Includes Items # 5 & 6)	1	F029		1/4-20 x 1/2 Hex Bolt	1
8	5221-1	Extension Spring (3/4 x 5)	1	F031		1/4-20 x 5/8 Hex Bolt	11
9	2358-11	Clutch Actuator	1	F034		5/16-18 x 3/4 Hex Bolt	9
10	5214-13	Ball Joint (3/8)	2	F035		5/16-18 x 1-1/4 Hex Bolt	2
11	2358-9	Clutch Pivot Base	1	F039		3/8-16 x 1-1/4 Hex Bolt	1
12	2358-8	Adjustor Brace	1	F051		3/8 SAE Washer	2
13	7775-6	Wire Lock Pin (2-1/2")	3	F058		1/4 Wave Spring Washer	6
14	2302-4	Right Hand Shoe	1	F060		AN960516 Washer	2
15	2302-7	Upper Shoe, LH	1	F061		1/4 Star Lock Washer	1
16	2302-3	Left Hand Shoe	1	F069		3/32 x 1/2 Cotter Pin	1
17	2349-7	Bearing Mount	1	F091		5/16-18 x 5/8 Hex Bolt	1
18	2406-5	Spacer	1	F104		1/4-20 x 3/4 PFH Bolt	2
19	2236-5	PTO Pulley (4.5/AAA)	1	F120		AN960416 Washer	8
20	2359-1	Brake Band / Guard Mount	1	F146		1/4-20 Jam Nut	1
21	7775-8	Wire Lock Pin (4")	1	F149		1/4 x 1/4 x 1-1/2 Key	1
22	2302-5	PTO Shoe	1	F168		5/16 Split Lock Washer	1
23	7275-9	Quick Coupler Installation Tool	**	F170		5/16 x 1 x 7/64 Flat Washer (Zinc Plate)	1
24	7275-16	Universal Joint Tube Assembly / Spline	1	F171		5/16-18 x 3/8 Set Screw	1
25	2274-10	PTO Drive Shaft Assembly	*	F178		1/4 x 1 Fender Washer	1
26	2302-6	Shoe Mount, LH	2	F182		1/4 x 5/8 x 1/8 Washer	1
27	2358-7	Clutch / Pivot Stop	1	F183		.312 x .700 x .074 Washer	4
28	7523-2	Clevis Pin W/Hole (1/4 x 5/8)	1	F211		1/4-20 x 7/8 Hex Bolt	2
29	4359-2	Brake Band Link, Rear	1	F217		7/16-14 Hex Nut	2
30	8304	Brake Band (14-1/2)	1	F218		7/16 Split Lock Washer	2
31	4359-1	Brake Band Link, Front	1	F219		7/16-14 x 1-1/4 Hex Bolt	2
32	2410-2	Drive Shaft	1	F241		.375 x .875 x .10 Washer	1
33	2265	Bearing (20mm)	4	F255		5/16-18 x 1-1/2 Hex Bolt	4
34	2406-7	Pivot Shaft Spacer	1	F298		3/8-24 Jam Nut	2
35	2236-1	Idler Pulley (4.5/AAA)	2	F350		1/4-20 LP Nylock	9
36	2230	Engine PTO Belt / Set (3)	1	F389		3/8-16 x 2-3/4 Hex Bolt	1
37	2236-6	Pulley (Includes Items # F149 & F171)	1	F431		1/4-20 x 3-1/2 Hex Bolt	1
38	2236-4	Idler Pulley Shaft	1	F435		1/4 x 1/4 x 1-1/4 Key	2
39	7201-3	Fiberglide Bearing	2	F450		Washer 5/8 x 1-3/4 x 1/4	1
40	7201-9	Inner Race	1	F452		5/8-18 Nylon Locknut	1
41	2359-2	Clutch Engagement (Includes Items # 3 & 39)	1	F473		5/16-18 x 5 Hex Bolt	1
42	2349-6	Flanged Bearing	1	F476		3/8-16 x 6-1/2 Hex Bolt	1
43	4302-2	Shoe Mount	1	F484		Washer .370 ID x 1.0 OD x .120	2
44	2358-12	Fiberglide Bushing	1				
45	7201-2	Fiberglide Bearing 1/2"	1				
46	7377	Plastic Washer (1 x .438 x .025)	2				
47	7378	Pivot Bearing (7/16 x 9/16)	1				
48	5214-2	Ball Joint (5/16-24) (Nylon Lined)	1				
49	7226	Compression Spring (3/4 x 2-1/2)	1				
50	7380	Knuckle Joint	1				

* Service Part Only

** The Quick Coupler Installation Tool is used to assist the installation of the Quick Coupler Tube and PTO Shaft connection by holding the disconnect ring in the retracted position when joined to the tractor spline shaft on the PTO Drive Shaft.

Beginning S/N 115338

Effective Date 07-19-12

Use only genuine **Walker**® replacement parts.

MAIN COMPONENT POWER TRANSMISSION

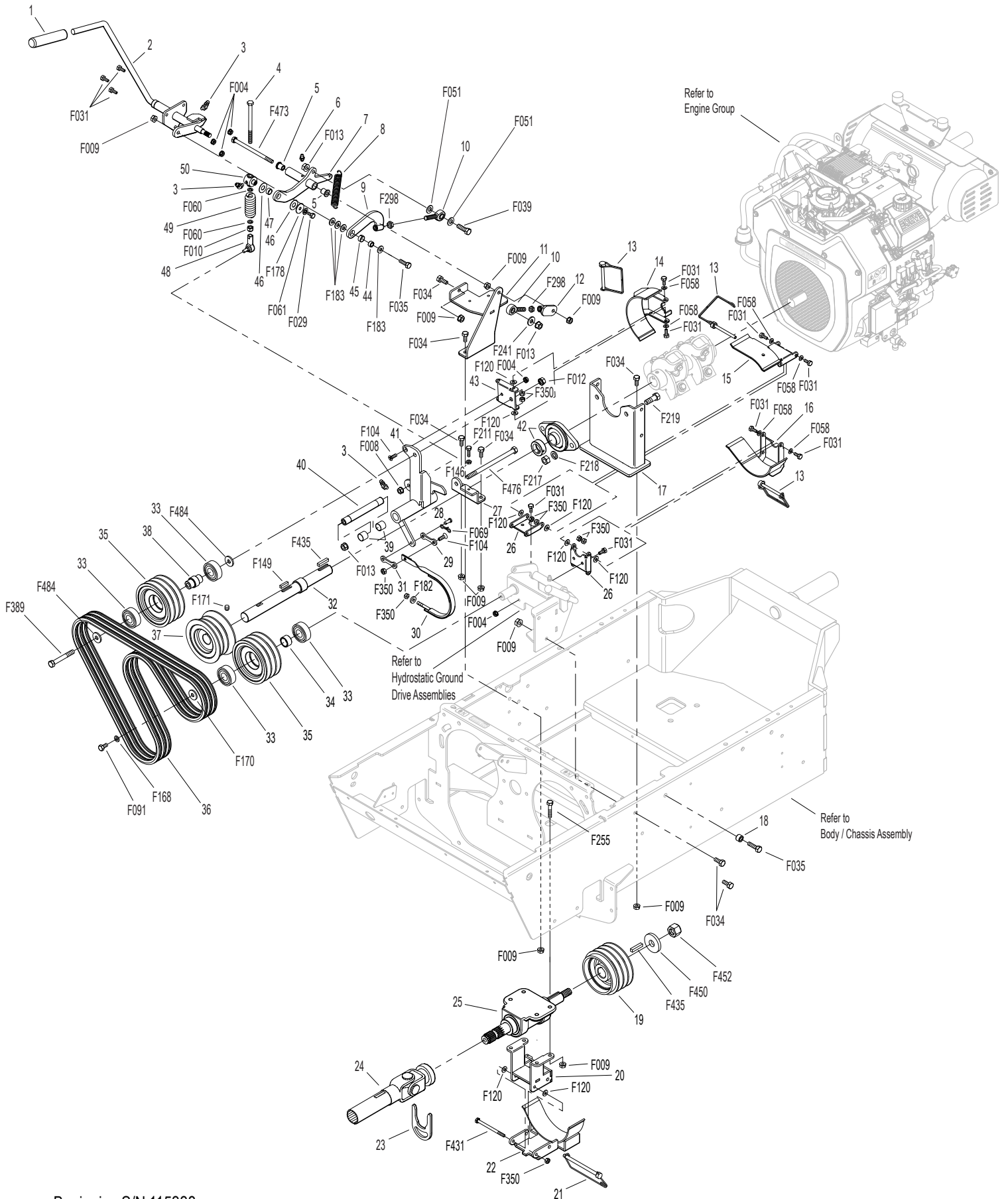

Beginning S/N 115338
 Effective Date 07-19-12
 Use only genuine **Walker**® replacement parts.

ENGINE GROUP

ITEM NO.	PART NO.	DESCRIPTION	NO. REQ'D	ITEM NO.	PART NO.	DESCRIPTION	NO. REQ'D
Fuel Tank Assembly				Precleaner Assembly			
1	5082-4	2-1/4 Ratchet Fuel Cap (EPA)	2	36	6029	Hose Clamp (2-1/2)	3
2	5083-1	Bushing, Rubber (Fits 5083)	4	37	2012-2	Air Intake Hose	1
3	8046-1	Diffuser	2	38	7026-2	Remote Precleaner	1
4	8043-5	Grommet	2	39	2088-10	Air Cleaner Assembly	*
5	8043-7	Elbow	2			(Includes Items # 39-45)	
6	5083-8	Tank Tube 13"	2	40	5091-2	Air Flow Indicator (Vacuum 10" H2O)	1
7	5879-3	Hose Clamp (1/2)	7	41	5091-9	Street Elbow 90' (1/8 x 1/8)	1
8	M111	Fuel Line (1/4 x 24")	1**	42	2088-1	Air Cleaner Band	1
9	M113	Fuel Line (3/16 x 9")	1**	43	2090-3	Safety Filter Insert	1
10	M113	Fuel Line (3/16 x 12")	1**	44	2090-1	Air Cleaner Cartridge	1
11	7014-9	Fuel Filter	1	45	2088-2	Air Cleaner Cap	1
12	8043-6	Connector "Y"	1	46	2090-2	Vacuator Valve	1
13	M111	Fuel Line (1/4 x 26-1/2")	1**	Choke and Throttle Assemblies			
14	5975-3	Cable Tie (50# x 7")	4	47	2108-4	Control Cable (68")	1
15	M113	Fuel Line (3/16 x 31")	1**	48	8123-3	Insultherm (3/8 x 10)	1
16	4010-1	Drain Valve 3/8-18 NPTF	1	49	5108-1	Control Lever, Throttle / Choke	1
17	2010-3	Fuel Valve	1	50	5108-5	Throttle Control Knob, Red	1
18	2010-14	Fuel Transfer Mount	1	51	5108-11	Friction Washer (.062)	1
19	M111	Fuel Line (1/4 x 11")	1**	52	7108	Control Assembly	1
20	8046-3	Fuel Tank, 4.7 Gallon, Gas (Includes Items # 2 & 7)	2			(Includes Items # 49, 51, 53-55 & F201)	
21	5086-7	Hose (1/4 x 6)	2		2108-3	Throttle Control and Cable Assembly	*
22	5020-2	Fuel Filter, In Tank	2			(Includes Items # 49-51, 53-56, F002, F005, F050, F164 & F201)	
Remote Oil Cooler Assembly				53	5108-8	Control Bracket	1
23	NS	Oil Cooler Hose (Kohler 24 326 130-S)	1	54	5108-10	Friction Washer (.125)	1
24	NS	Oil Cooler Hose (Kohler 24 326 129-S)	1	55	5108-7	Control Lock Tab	1
25	NS	Clamp (Kohler 24-237-16-S)	4	56	5172	Bearing, Delrin (.255 ID x .379 OD x .250)	1
26	NS	Oil Cooler (Kohler 24-594-42-S)	1	Fasteners			
27	4016	Oil Cooler Mount	1	F002	10-24 Keps Nut		7
Engine Assembly				F004	1/4-20 Keps Nut		4
28	2104-1	Body Support	1	F005	1/4-20 ESNA Nut		1
29	4845	Rubber Bumper (1.0 x .625)	2	F009	5/16-18 Whiz Locknut		4
30	NS	Kohler Nut	*	F025	10-24 x 3/8 PPHMS		6
31	2013-4	Shield Side	2	F031	1/4-20 x 5/8 Hex Bolt		2
32	2013-3	Muffler Heat Shield	1	F034	5/16-18 x 3/4 Hex Bolt		4
33	NS	Oxygen Sensor (Kohler 25 418 07-S)	1	F050	1/4 SAE Washer		1
34	NS	Muffler (Kohler 24 786 33-S)	*	F164	10-24 x 1/4 x 3/8 SHL Bolt		1
35	NS	29 HP Engine (Pulse Pump) (Kohler, Spec. # ECH 749-3028)	*	F175	1/2 Split Lock Washer		4
	NS	29 HP Engine (Kohler, Spec. # 749-3017)	*	F184	1/4-20 x 1/2 Hex Bolt, SS		4
				F185	1/4 Internal Star Lock Washer, SS		4
				F201	1/4 Belleville Spring Washer		2
				F439	1/2-13 x 1-3/4 Hex Bolt		4

* Service Part Only

** **Required hose specifications:**

M111 - 1/4" ID fuel/oil/vapor hose (Gates 4219-0103 or equivalent)

M113 - 3/16" ID fuel/oil/vapor hose (Gates 4219-0093 or equivalent)

Beginning S/N 115338

Effective Date 07-19-12

Use only genuine **Walker®** replacement parts.

ENGINE GROUP

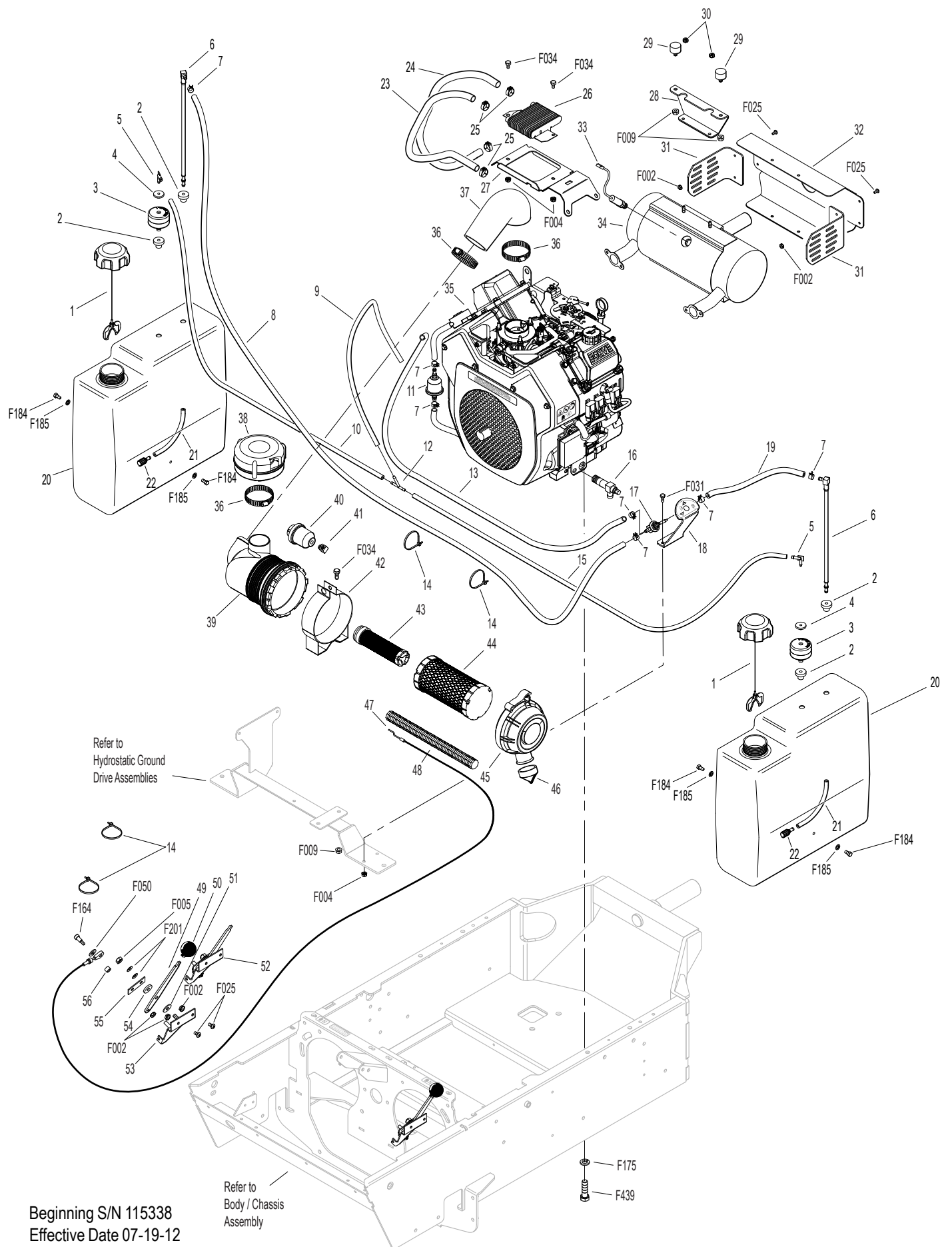

HYDROSTATIC GROUND DRIVE ASSEMBLIES

ITEM NO.	PART NO.	DESCRIPTION	NO. REQ'D	ITEM NO.	PART NO.	DESCRIPTION	NO. REQ'D
Parking Brake Assembly				49	7201-5	Inner Race (2-1/4)	1
1	2358-6	5/16-18 x 1-3/4 Stud	2	50	2300-5	Spring Mount Plate (Prior to S/N 118509)	1
2	2300-2	Parking Brake Hydro Mount, RH	1		2300-7	Spring Mount Plate (Beginning S/N 118509)	1
3	5103-2	Pivot Bushing (5/16 ID)	2	51	2028-3	Hydro Lockout Rod, LH	1
4	2406-3	Parking Brake Actuator Tube	1	52	9430-1	Spacer Tube	4
5	5222	Extension Spring (1/2 x 3-1/4)	1	53	2349-9	Idler Mount	1
6	2280	Clevis (3/8)	1	54	2025-13	Hydro-Gear ZT3400, LH	1
7	2406-4	Clevis Pin (5/16 x 1-1/8)	1	55	2026-13	Hydro-Gear ZT3400, RH	1
8	8655-4	Clevis Pin (5/16 x 3/4)	2	Wheel Assembly			
9	2406-1	Brake Actuator Pull	1	56	2071	Wheel & Tire (22 x 10.50-12)	2
10	4407-4	Bow Tie Cotter Pin	6	PTO Coupler			
11	5830-4	Grease Fitting (90 Deg.)	1	57	2351-3	Flex Coupler Half (Includes Items # F171 & F435)	2
12	7406-1	Handle Grip, Red	1	58	2351-7	Inner Flex Coupler Half / MBS (1/4)	1
13	2406-8	Parking Brake Lever Idler Mount (Includes Items # 11 & 12)	1	59	2351-1	Rubber Coupler	6
14	2406-5	Spacer	1	Fasteners			
15	2300-1	Parking Brake Hydro Mount, LH	1	F003		1/4-28 Hex Nut	2
16	5281-5	Clevis Pin (1/4 x 0.80)	2	F004		1/4-20 Keps Nut	9
17	5280	Clevis (1/4)	2	F005		1/4-20 ESNA Nut	2
18	2406-2	Parking Brake Rod	2	F009		5/16-18 Whiz Locknut	13
19	5665-1	Compression Spring (2-1/2)	2	F010		5/16-24 ESNA Nut	4
20	5463	Steering Lever Actuator	2	F012		3/8-16 Keps Nut	4
Transaxle Reservoir Assemblies				F013		3/8-16 Whiz Locknut	7
21	2025-17	Straight Thread Hose Fit	2	F015		1/2-20 Wheel Lug Nut	8
22	5879-4	Hose Clamp (7/16)	2	F029		1/4-20 x 1/2 Hex Bolt	4
23	2025-14	Hose Channel	1	F031		1/4-20 x 5/8 Hex Bolt	1
24	6836-1	Clamp, Double (1/2 x 1/2)	3	F032		1/4-20 x 3/4 Hex Bolt	2
25	5086-14	Hose (1/4 x 26-1/4")	1	F034		5/16-18 x 3/4 Hex Bolt	16
26	5879-3	Hose Clamp (1/2)	2	F035		5/16-18 x 1-1/4 Hex Bolt	1
27	4024-1	Oil Expansion Reservoir Elbow	2	F039		3/8-16 x 1-1/4 Hex Bolt	2
28	2010-9	Hose Reducer (1/2-1/4)	2	F040		3/8-16 x 1-1/2 Hex Bolt	2
29	5879-8	Hose Clamp (13/16)	4	F043		3/8-16 x 3 Hex Bolt	1
30	5087-1	Hose (1/2 x 1-3/4)	2	F049		5/16 SAE Washer	2
31	2025-1	Oil Expansion Reservoir	2	F050		1/4 SAE Washer	7
32	5879-7	Hose Clamp (5/8)	2	F051		3/8 SAE Washer	2
33	2025-8	Reservoir Bottom Caps	2	F052		5/16 Ext. Star Lock Washer	12
34	5086-15	Hose (1/4 x 23)	1	F116		1/4-20 x 1-1/4 Hex Bolt	1
35	2025	Reservoir Bottle Mount	1	F169		5/16-18 x 1 Carriage Bolt	2
Ground Drive Assemblies				F171		5/16-18 x 3/8 Set Screw	6
36	2028-4	Hydro Lockout Rod, RH	1	F179		1/4-20 x 1 Hex Bolt	2
37	2248	Ground Drive Belt	1	F182		1/4 x 5/8 x 1/8 Washer	4
38	4245	Idler Pulley (3/A)	2	F183		.312 x .700 x .074 Washer	3
39	4349-6	Flanged Bearing (1") (Prior to S/N 118509)	1	F231		1/4 x 3/4 Woodruff Key (#806)	1
	4349-9	Flanged Bearing (1") (Beginning S/N 118509)	1	F306		3/8-16 x 3/4 Hex Bolt	2
40	2240-2	Drive Pulley (Includes Item # F171)	1	F336		3/8-16 Jam Nut	1
41	2349-8	Tensioner Rod	1	F350		1/4-20 LP Nylock	2
42	7223-2	Compression Spring (1/2 x 6-1/2")	1	F388		3/8-16 x 2-1/2 Hex Bolt	4
43	2724-8	Tensioner Guide	1	F434		5/16-18 x 3-1/2 Hex Bolt	4
44	5221-1	Extension Spring (3/4 x 5)	1	F435		1/4 x 1/4 x 1-1/4 Key	2
45	5830-3	Grease Fitting (45 Deg.)	1	F447		1/4 x 1/4 x 1 Key	1
46	5841	Retainer Washer (3/8 x 1-1/4)	1	F481		Washer 5/16 x 7/8 x .125	12
47	7201-3	Fiberglide Bearing	2	F490		5/16-18 ESNA Wing Nut	1
48	2349-5	Hydro Idler Arm (Includes Items # 45 & 47)	1				

Beginning S/N 115338

Effective Date 07-19-12

Use only genuine **Walker**® replacement parts.

HYDROSTATIC GROUND DRIVE ASSEMBLIES

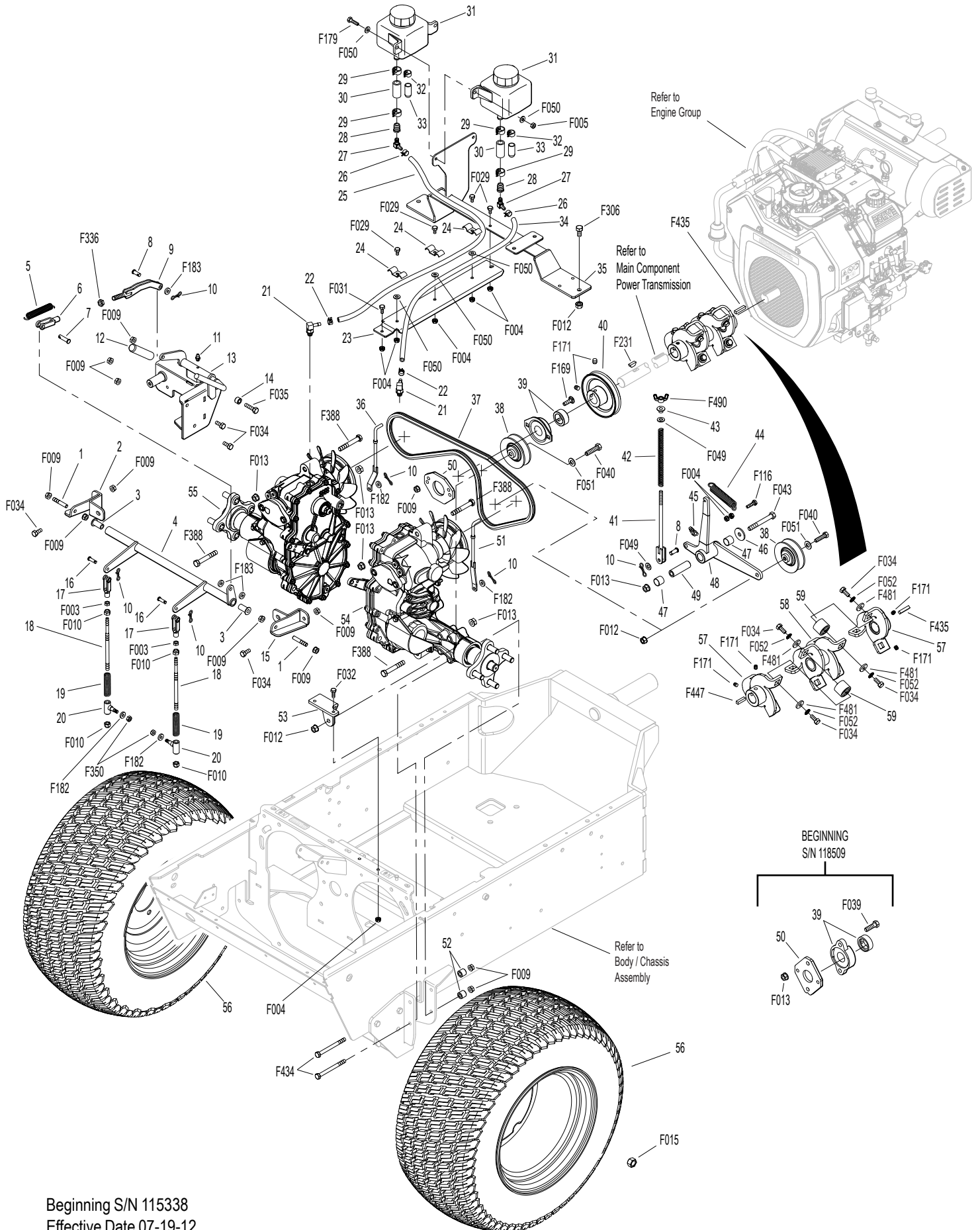

Beginning S/N 115338
 Effective Date 07-19-12
 Use only genuine Walker® replacement parts.

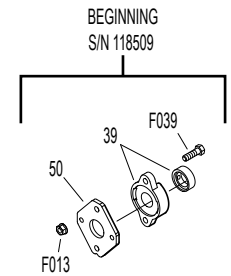

STEERING CONTROL ASSEMBLIES

ITEM NO.	PART NO.	DESCRIPTION	NO. REQ'D	ITEM NO.	PART NO.	DESCRIPTION	NO. REQ'D
Steering Lever & FSC Assemblies				Transmission Spring Assemblies			
1	5862	FSC Knob	1	39	4199	Transmission Spring Assembly (Includes Items # 40-46, F004, F211, F320 & F352)	*
2	4170	FSC Lever Assembly (Includes Item # 4)	*	40	4552	Ball Joint (1/4-28)	2
3	2170-1	Step Washer	1	41	5194	Plunger Sleeve	2
4	5830	Grease Fitting	1	42	5192-2	Spring Plunger (Female)	2
5	5214-5	Ball Joint (5/16-24/LH) W/O Stud	1	43	5193	Washer (3/4 x 1 x .085)	2
6	4213	Control Rod (6-1/4)	1	44	6191	Spring Slide (4-3/4)	2
7	5214-4	Ball Joint (5/16-24) W/O Stud	1	45	5195	Compress Spring (1 x 5-1/8)	2
8	5463-2	Steering Lever Actuator	2	46	6196	Spring Slide Cap	2
9	5665-1	Compression Spring (2-1/2)	2	Fasteners			
10	2213	Control Rod (7")	2				
11	2212-3	Seal Retainer	2				
12	2212	Transmission Control Arm Stop	2				
13	2212-2	Transmission Control Arm, RH	1	F003		1/4-28 Hex Nut	2
14	5214-2	Ball Joint (5/16-24) (Nylon Lined)	2	F004		1/4-20 Keps Nut	4
15	2212-1	Transmission Control Arm, LH	1	F005		1/4-20 ESNA Nut	2
16	2451-1	Steering Pivot Shaft With Stop	1	F008		5/16-24 Keps Nut	2
17	5830-3	Grease Fitting (45 Degree)	1	F009		5/16-18 Whiz Locknut	6
18	7201-2	Fiberglide Bearing (1/2")	2	F010		5/16-24 ESNA Nut	2
19	2463	Actuator Washer	2	F024		5/16-24 Jam Nut	3
20	8201-3	Fiberglide Bearing	4	F029		1/4-20 x 1/2 Hex Bolt	2
21	2451-5	Speed Control Actuator, LH (Includes Items # 17 & 20)	1	F035		5/16-18 x 1-1/4 Hex Bolt	1
22	5146	10mm Ball Stud	4	F044		5/16-24 x 3/4 Hex Bolt	2
23	2215-5	Steering Lever Dampener	2	F059		3/8 Wave Spring Washer	1
24	2451-6	Speed Control Actuator, RH (Includes Items # 20 & 25)	1	F093		5/16-18 x 1 Hex Bolt	2
25	5830-4	Grease Fitting (90 Deg.)	1	F121		5/16-18 x 3/8 x 1 SHL Bolt	1
26	4451-4	FSC Friction Actuator	1	F146		1/4-20 Jam Nut	2
27	4219	Extension Spring (3/4 x 6-1/2)	1	F167		5/16-18 Hex Nut	1
28	5850-2	Handle Grip, Foam (5-1/2)	2	F183		.312 x .700 x .074 Washer	6
29	5453-20	Steering Lever Handle (+1") Adjustable / SS (Includes Items # 28, F188, F198 & F345)	2	F188		1/4-20 Self-Locking Nut	4
30	4452-4	Steering Lever Tube W/Tab	2	F192		3/8-24 Self-Locking Nut	1
31	5450	D-Clip	2	F198		.250 x .625 x .040 Washer, SS	2
32	5222	Extension Spring (1/2 x 3-1/4)	2	F211		1/4-20 x 7/8 Hex Bolt	3
33	4452-6	Steering Pivot (1/4-20 x 1-5/8)	2	F320		1/8 x 3/4 Split Spring Pin	2
34	4142-1	FSC Cam	1	F345		1/4-20 x .770 Knurled Bolt	4
35	5141	FSC Friction Washer (1-1/2 x 3/8 x 1/16)	1	F352		5/32 x 1 Heavy Duty Roll Pin	2
36	4142-2	FSC Friction Washer (1-1/2 x 1-1/32 x 1/16)	1	F373		5/16-24 Hex Nut, LH	1
37	9704-3	Pivot Rod Bushing, Plastic	2	F385		1/4 x 1-1/4 Roll Pin	1
38	2451-4	Steering Shaft Spacer	1	F386		5/16-18 x 1-1/2 x 3/8 Shoulder Bolt	1
				F391		1/4-20 x 1/2 Set Screw, SS	2
				F407		Belleville Washer 3/8 x 1.187, SS	1
				F427		5/16-18 Flange Nut	1
				* Service Part Only			

STEERING CONTROL ASSEMBLIES

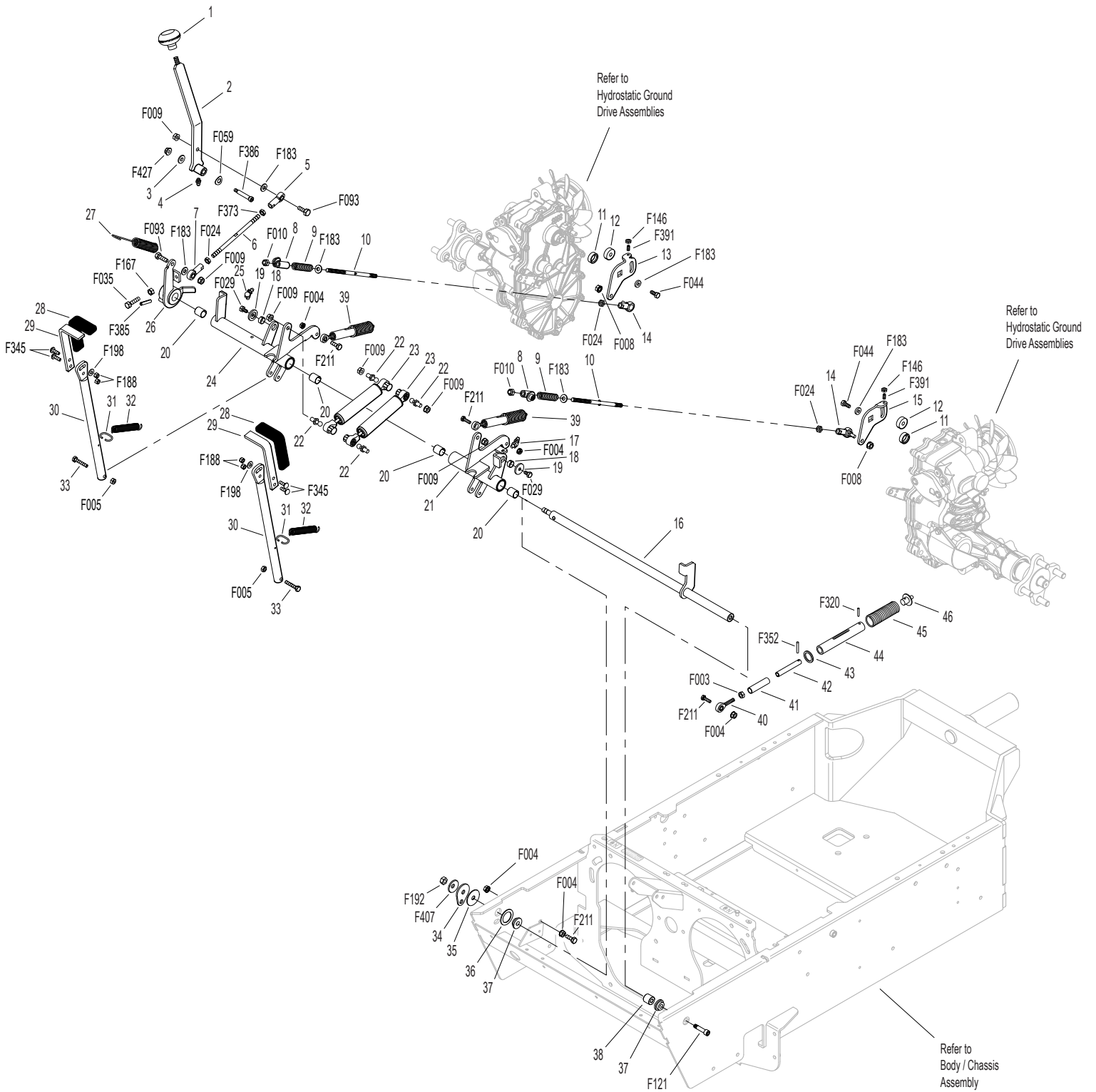

Beginning S/N 115338
Effective Date 07-19-12
Use only genuine **Walker**® replacement parts.

ELECTRICAL ASSEMBLY

ITEM NO.	PART NO.	DESCRIPTION	NO. REQ'D	ITEM NO.	PART NO.	DESCRIPTION	NO. REQ'D
Electrical Assembly				24	5933	Battery Terminal Insl., Red (+)	1
1	8960-15	Ignition Switch W/Keys (Includes Items # 2, 3 & F349)	1	25	5932	Battery Terminal Insl., Blk (-)	1
2	7854	Plastic Tip, Red	1	26	5844	Battery Hold-Down Bar	1
3	8960-3	Key Set W/Umbrella	1	27	2910-1	Battery Shield	1
4	7941-3	Boot, Circuit Breaker	1	28	5839	Hook Bolt	2
5	7941-6	Circuit Breaker (15 Amp)	1	29	8941	Circuit Breaker (30 Amp) (Auto Reset/Sealed)	1
6	8990-1	Hourmeter (Global)	1	30	5833	Cable Clamp (1/4)	1
7	8996-2	Red Indicator Light Assembly (Includes Items # 10 & 11)	2	31	2940-13	Wire Harness, MBS29	1
8	8996-10	Amber Indicator Light Assembly	1	32	5942-4	PTO Safety Switch (NO)	1
9	8536-2	Warning Horn Assembly	1	33	6941-7	Relay Mount	*
10	8996-4	Red Indicator Lens (Includes Items # 11 & 12)	2	34	6941-6	Relay Switch 30/40AMP	*
11	8996-3	Indicator Bulb (Replacement for P/N 8996-2)	*	Fasteners			
12	8996-6	Amber Indicator Lens	1	F002	10-24 Keps Nut		13
13	6105-3	Harness Clip	3	F004	1/4-20 Keps Nut		2
14	2940-4	Seat Switch Harness	1	F009	5/16-18 Whiz Locknut		1
15	6942	Relay Switch 30/40 Amp (NC) (Includes Items # 33 & 34)	3	F019	1/4-20 ESNA Wing Nut		2
16	7948-6	Time Delay Module (.5 Second Delay)	1	F026	10-24 x 1/2 PPHMS		13
17	7948-5	Time Delay Harness	1	F031	1/4-20 x 5/8 Hex Bolt		2
18	5941-2	Safety Switch	1	F034	5/16-18 x 3/4 Hex Bolt		1
19	7833-2	Cable Clamp (1 x 1/4)	2	F050	1/4 SAE Washer		4
20	7938	Lead Wire, Battery Charge (Alternator to Starter)	1	F232	10-32 Keps Nut		2
21	2940-3	Battery Cable (14")	2	F349	Washer .835 ID 1.122 OD, SS		1
22	NS	Battery (12V/275CCA/Dry)	1	* Service Part Only			
23	5975-1	Cable Tie (18# x 3-3/4")	2				

ELECTRICAL ASSEMBLY

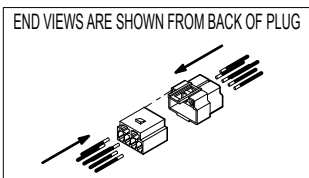
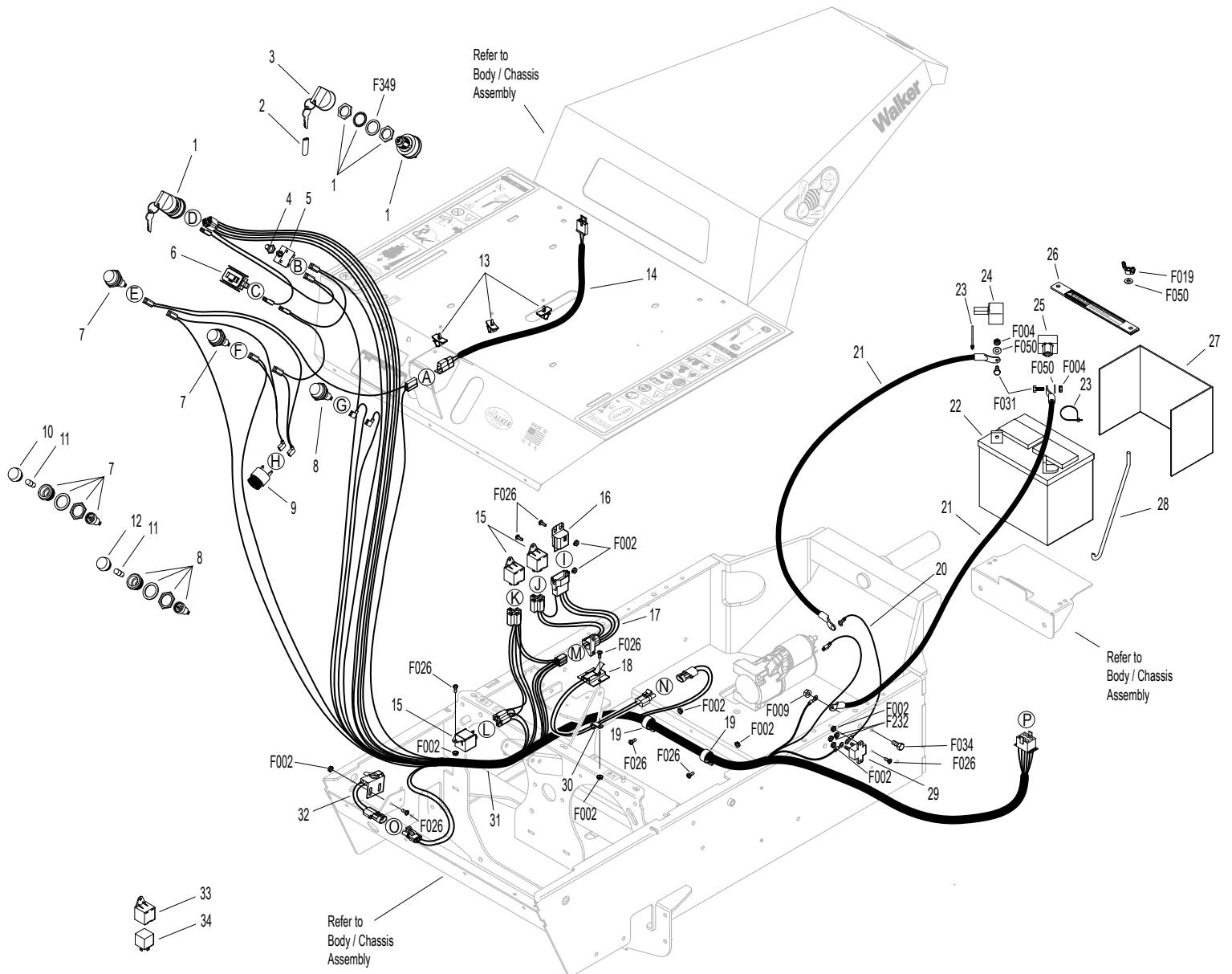

DETAIL A



DETAIL B



DETAIL C



DETAIL D



DETAIL E



DETAIL F



DETAIL G



DETAIL H



DETAIL I



DETAIL J



DETAIL K



DETAIL L



DETAIL M



DETAIL N



DETAIL O



DETAIL P



Beginning S/N 115338
Effective Date 07-19-12
Use only genuine Walker® replacement parts.

LUBRICATION POINTS

ITEM NO.	LOCATION	LUBRICATION TYPE	NO. PLACES	ITEM NO.	LOCATION	LUBRICATION TYPE	NO. PLACES
Lubrication Points							
1	Steering Lever Pivot	Grease	2	10	Clutch Arm Pivot	Grease	1
2	Deck-to-PTO Coupling (Grease Spline Slide Area)	Grease	1	11	Transaxle Oil Reservoir	Oil	2
3	Deck Support Arm Pivot	Grease	2	12	Throttle Control Cable Ends	Oil	2
4	Universal Joint Tube Assembly	Grease*	1	13	Engine Dipstick	Oil**	1
5	FSC Lever Pivot	Grease	1	14	Tail Wheel Caster Fork Pivot	Grease	2
6	Hydro Idler Arm Pivot	Grease	1	15	Rear Wheel Pivot	Grease	1
7	Clutch Actuator Push Rod	Grease	1	16	Rear Wheel Bearing	Grease	2
8	Body Latch Pivot	Oil	2	17	Engine / Oil Filler	Oil**	1
9	PTO Clutch Lever Pivot	Grease	1	18	PTO Belt Tightener Pivot	Grease	1
				19	Parking Brake Pivot	Grease	1
				20	Throttle Control Pivot	Oil	1

* Grease every eight (8) hours.

** Refer to MBS29 **Operator's Manual** for procedure for checking and changing oil in Engine Crankcase.

NOTE: See Model MBS29 **Operator's Manual** (P/N 2000-7) for proper lubrication intervals.

LUBRICATION POINTS

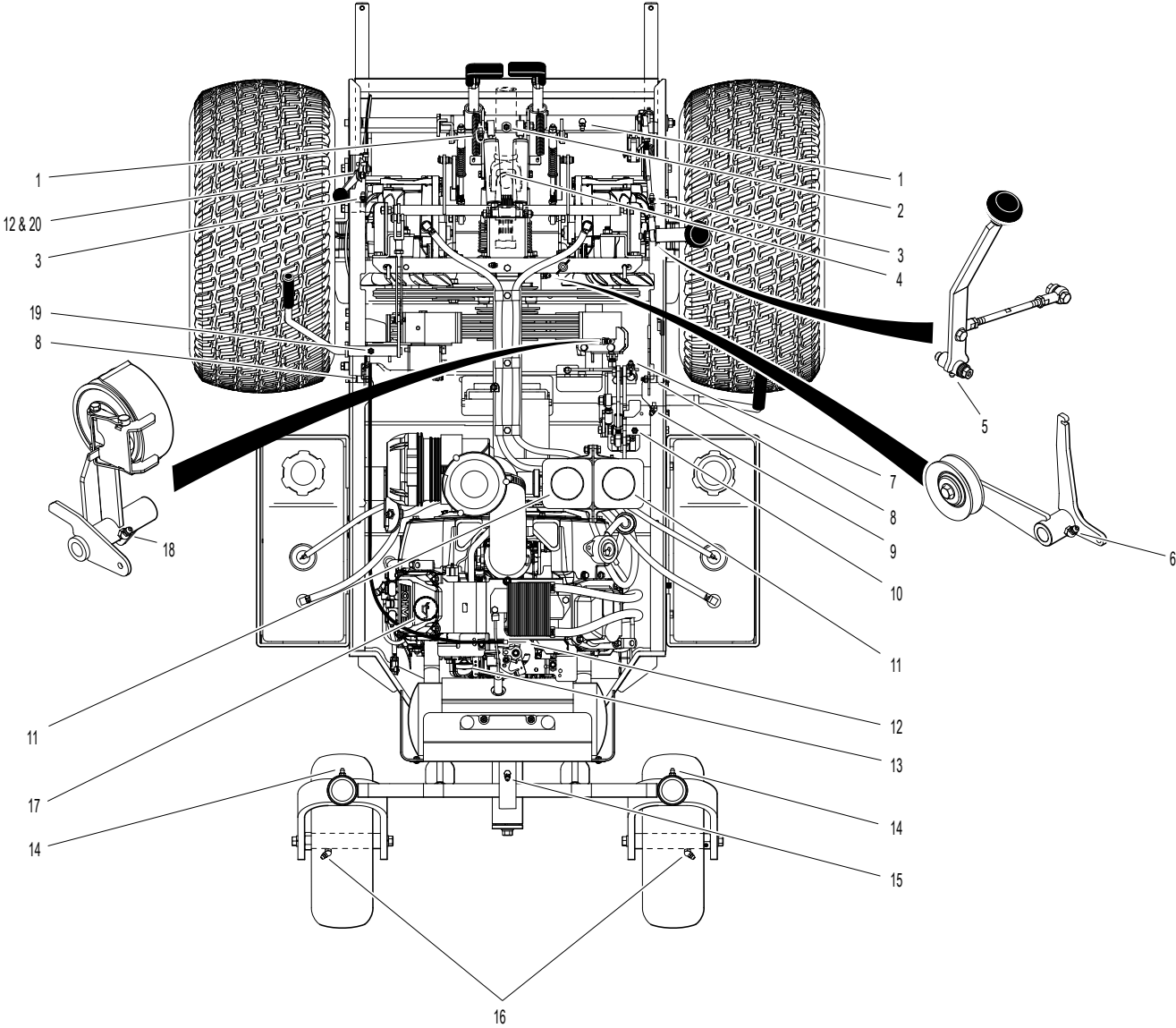

Beginning S/N 115338
Effective Date 07-19-12
Use only genuine **Walker**® replacement parts.

WIRING SCHEMATIC

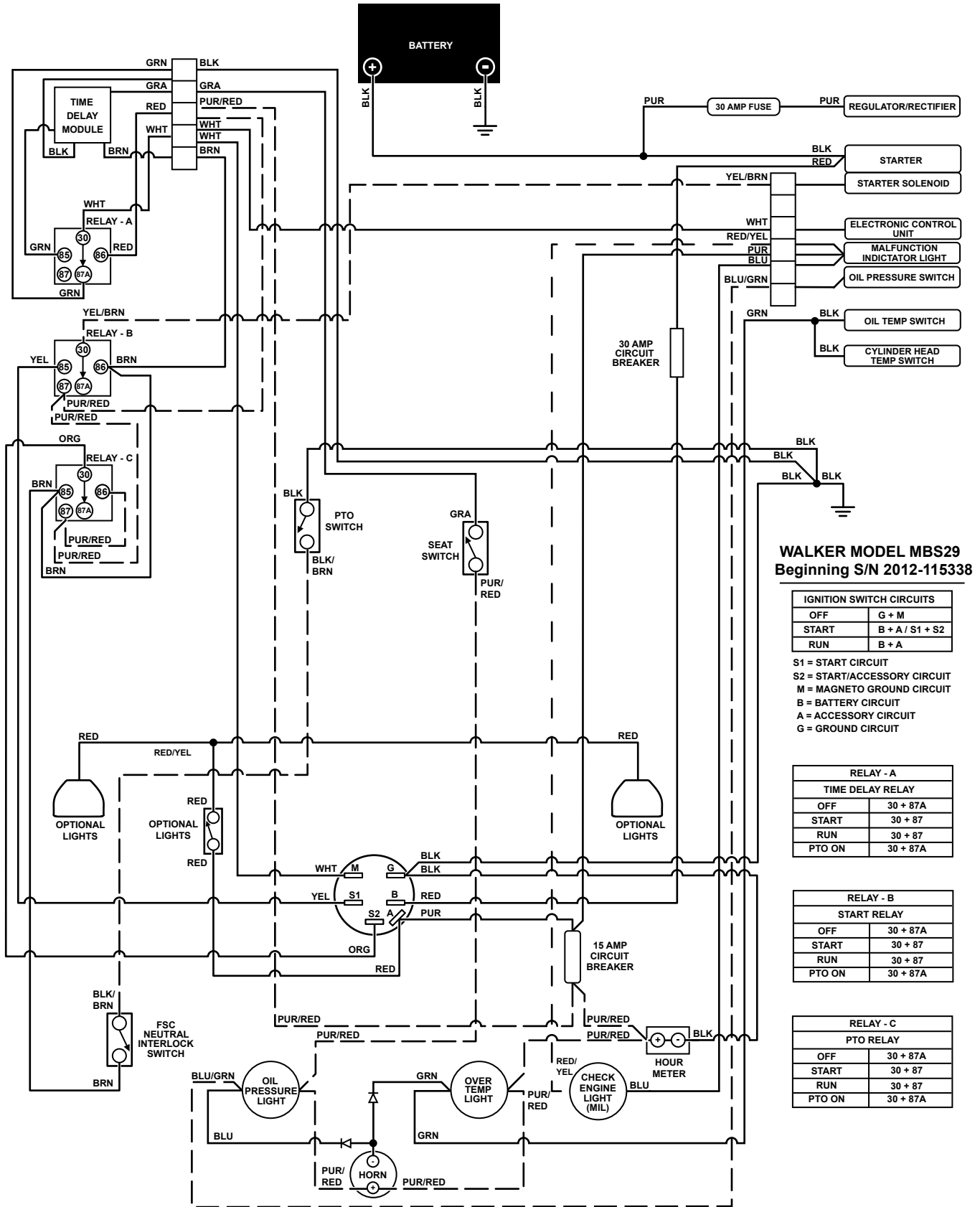

WALKER MODEL MBS29
Beginning S/N 2012-115338

IGNITION SWITCH CIRCUITS	
OFF	G + M
START	B + A / S1 + S2
RUN	B + A

S1 = START CIRCUIT
S2 = START/ACCESSORY CIRCUIT
M = MAGNETO GROUND CIRCUIT
B = BATTERY CIRCUIT
A = ACCESSORY CIRCUIT
G = GROUND CIRCUIT

RELAY - A	
TIME DELAY RELAY	
OFF	30 + 87A
START	30 + 87
RUN	30 + 87
PTO ON	30 + 87A

RELAY - B	
START RELAY	
OFF	30 + 87A
START	30 + 87
RUN	30 + 87
PTO ON	30 + 87A

RELAY - C	
PTO RELAY	
OFF	30 + 87A
START	30 + 87
RUN	30 + 87
PTO ON	30 + 87A

OPERATOR'S NOTES

OPERATOR'S NOTES

LIMITED WARRANTY FOR WALKER MODEL MBS29 RIDER MOWER

1. WHAT THIS WARRANTY COVERS, AND FOR HOW LONG:

Walker Manufacturing company will, at its option, repair or replace, without charge, any part covered by this warranty which is found to be defective in material and/or workmanship within one (1) year after date of sale to the original retail purchaser unless the product is used for rental purposes, in which case this warranty is limited to ninety (90) days. At Walker's request, customer will make the defective part available for inspection by Walker and/or return the defective part to Walker, transportation charges prepaid. All parts and components of the Walker Mower are covered by this warranty **except** the following components which are warranted separately by their respective manufacturers:

Kohler Engine
Yanmar Engine
Hydro-Gear Transaxles
Battery
Tires

The available warranties covering these items are furnished with each mower. Walker does not assume any warranty obligation, liability or modification for these items, which are covered exclusively by the stated warranty of the respective manufacturers noted above.

2. WHAT THIS WARRANTY DOES NOT COVER:

- A. This warranty does not cover defects caused by depreciation or damage caused by normal wear, accidents, improper maintenance, improper use or abuse of the product, alterations, or failure to follow the instructions contained in the Operator's Manual for operation and maintenance.
- B. The customer shall pay any charges for making service calls and/or for transporting the mower to and from the place where the inspection and/or warranty work is performed.

3. HOW TO OBTAIN SERVICE UNDER THIS WARRANTY:

Warranty service can be arranged by contacting the dealer where you purchased the mower or by contacting Walker Manufacturing Company, 5925 East Harmony Road, Ft. Collins, CO 80528. Proof of the date of purchase may be required to verify warranty coverage.

4. WARRANTY LIMITATION:

- A. **THERE IS NO OTHER EXPRESS WARRANTY. ANY WARRANTY THAT MAY BE IMPLIED FROM THIS PURCHASE INCLUDING MERCHANTABILITY AND FITNESS FOR A PARTICULAR PURPOSE IS HEREBY LIMITED TO THE DURATION OF THIS WARRANTY AND TO THE EXTENT PERMITTED BY LAW ANY AND ALL IMPLIED WARRANTIES ARE EXCLUDED.** Some states do not allow limitations on how long an implied warranty lasts, so the above limitations may not apply to you.
- B. **WALKER WILL NOT BE LIABLE FOR ANY INCIDENTAL, CONSEQUENTIAL, OR SPECIAL DAMAGES AND/OR EXPENSES IN CONNECTION WITH THE PURCHASE OR USE OF THE MOWER.** Some states do not allow the exclusion or limitation of incidental or consequential damages, so the above limitation(s) or exclusion(s) may not apply to you.
- C. Only the warranty expressed in this limited warranty shall apply and no dealer, distributor, or individual is authorized to amend, modify, or extend this warranty in any way. Accordingly, additional statements such as dealer advertising or presentations, whether oral or written, do not constitute warranties by Walker, and should not be relied upon.
- D. This warranty gives you specific legal rights, and you may also have other rights which vary from state to state.

WALKER MOWERS

WALKER MFG. CO. • 5925 E. HARMONY ROAD, FORT COLLINS, CO 80528 • (970) 221-5614
FORM NO. 071912 PRINTED IN USA www.walkermowers.com ©2012 WALKER MFG. CO