

# WALKER

## Illustrated Parts Manual

### *T30i*



Beginning S/N: 124884  
Effective Date: 10.07.13  
P/N 8000-19

# KEY TO ABBREVIATIONS USED IN THIS MANUAL

<i>Abbreviation</i>	<i>What it Represents</i>
° (Dimension)	Degrees (Angle)
" (Dimension)	inches
(-)	Negative (Polarity)
(+)	Positive (Polarity)
AT	All-Terrain
CCW	Counter-clockwise
Conn	Connector
CW	Clockwise
D	Diameter
DC	Deck, Collection (number refers to size in inches)
DM	Deck, Mulching (number refers to size in inches)
DR	Deck, Rear Discharge (number refers to size in inches)
DS	Deck, Side Discharge (number refers to size in inches)
DU	Garlock (Bearing)
ESNA (Fastener)	Nylon Insert Locknut
FSC	Forward Speed Control
GA	Gauge
gal	gallon
GHS	Grass Handling System
GR (Fastener)	Grade
HD	Heavy Duty
HP	Horse Power
ID	Identification or Inside Diameter
L	Length
LH	Left Hand (orientated with operator on seat)
LP	Low Profile
mm (Dimension)	millimeters
MS (Fastener)	Machine Screw
NS (as part number)	Item is not sold by Walker Manufacturing
OD	Outside Diameter
oz	ounce
PFH (Fastener)	Phillips Flat Head
P/N	Part Number
PPH (Fastener)	Phillips Pan Head
PTH (Fastener)	Phillips Truss Head
PTO	Power Take-Off
QKS	Quick Slide
qt	quart
RH	Right Hand (orientated with operator on seat)
SAE (Fastener)	Society of Automotive Engineers
SBH (Fastener)	Socket Button Head (Bolt)
SD	Side Discharge
SFH (Fastener)	Slotted Flat Head
SHC (Fastener)	Socket Head Cap
SHL (Fastener)	Shoulder (Bolt)
SM (Fastener)	Sheet Metal (Screw)
S/N	Serial Number
Spg	Spring
SQH (Fastener)	Square Head
SS (Fastener)	Stainless Steel
ST (Fastener)	Self-Tapping (Screw)
Term	Terminal
V	Volts

**NOTE:** In some instances, combinations of abbreviations may be used (e.g. PPHMS - Phillips Pan Head Machine Screw).

Beginning S/N 124884

Effective Date 10-07-13

Use only genuine **Walker**® replacement parts.

# ILLUSTRATED PARTS LIST

<i>Section of Tractor Covered</i>	<i>Page</i>	<i>Section of Tractor Covered</i>	<i>Page</i>
<hr/>		<hr/>	
<b>Decals</b>		<b>Electrical Components</b>	
Tractor Decals .....	2	Electrical Assembly .....	32
<b>Body / Chassis Assemblies</b>		Electrical Assembly (EFI Components).....	34
Body / Chassis Assembly .....	4	Electrical Assemblies	
Rear Body Assembly .....	6	(GHS 10.0 Bushel Components).....	36
<b>Tractor Components</b>		Electrical Connectors.....	38
Main Component Power Transmission .....	8	<b>Maintenance</b>	
Engine Group.....	10	Lubrication Points .....	40
Engine Group (Fuel Components) .....	12	Wiring Schematic.....	42
Radiator Group .....	14	<b>Operator's Notes</b> .....	44
Hydrostatic Ground Drive Assemblies.....	16	<b>Warranty</b>	
Steering Control Assemblies.....	18	Limited Warranty .....	45
Throttle Control Assembly.....	20		
Parking Brake Assembly .....	22		
GHS Group .....	24		
GHS Powerfil® Assembly (10.0) .....	26		
GHS 10.0 Bushel Catcher Assembly.....	28		
Instrument Panel Assembly .....	30		

# TRACTOR DECALS

ITEM NO.	PART NO.	DESCRIPTION	LOCATION	NO. REQ'D GHS
<b>Walker Product and Operation Decals</b>				
1	8600-33	RH Fender	Body, RH Side Near Seat	1
2	5800-11	Walker (8" Round)	10.0 Bushel Catcher (one on each side)	2
3	8821-12	Decal, T30i	Body	1
4	5856-1	Made in USA	Body	1
<b>Danger Decals Warning Decals Caution Decals</b>				
5	8600-34	Warning, Read Manual	Body	1
6	5810-3	Decal, Hydro Warning	Bridge Assembly and LH Gear Axle Drive Assembly	2
7	8600-12	Danger, Engine Exhaust	Front Body, LH Side	1
8	8600-10	Danger, Pinch Point	10.0 Bushel Catcher Mounting Frame Assembly (one on each side)	2
9	8600-4	Danger, Rotating Blower Blades	Body, Near Body Chute	1
<b>Maintenance Decals</b>				
10	8600-30	Parking Brake	Body, RH Side Below Seat	1
11	8600-23	Body Latch Decal	Body, RH Side Below Seat	1
12	5082-5	Fuel Recommendations	Precleaner Tube	1
13	5855	Important, Engine Cooling	Engine	1
14	5869	Removable Screen	10.0 Bushel Catcher Removable Screen	1
15	8600-16	Front Body Closure	Rear Cross Member, Body	1
16	7827	Oil Level	Jackshaft Support	1
17	5810-1	Axle Oil Level	Gear Axle Drive Assemblies (one on each)	2
18	8600-31	Throttle	Body, LH Side	1
19	6875	PTO Alignment Arrow	Universal Joint Tube Assembly	1
20	NS	Sealed Reservoir	Hydrostatic Drives (one on each)	2

**NOTE:** All parts requiring decals are shipped with decals applied.

# TRACTOR DECALS

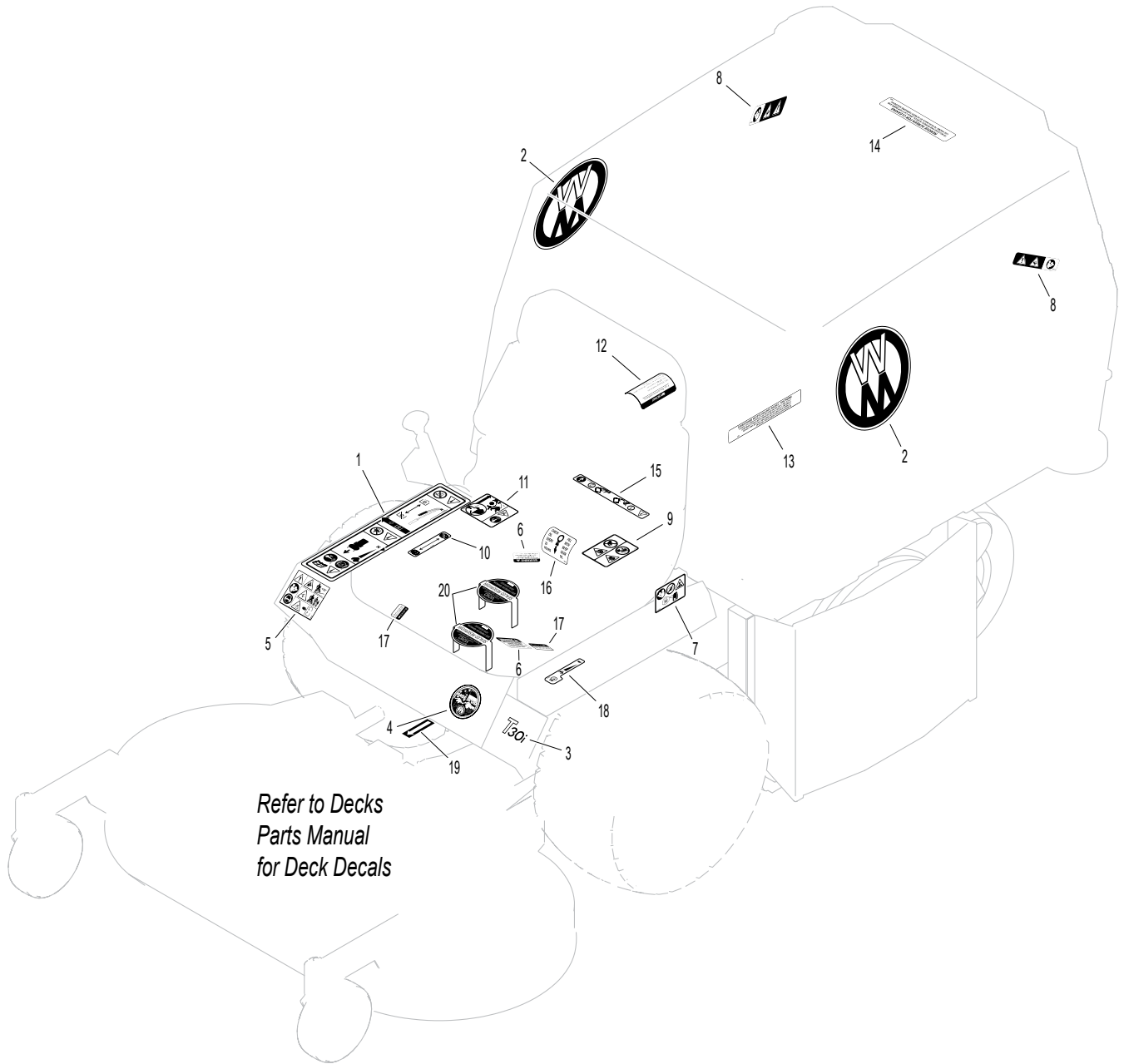

# BODY / CHASSIS ASSEMBLY

ITEM NO.	PART NO.	DESCRIPTION	NO. REQ'D	ITEM NO.	PART NO.	DESCRIPTION	NO. REQ'D
<b>Seat Assembly</b>				44	8037-1	Seal, Outer (1-3/4 x 1-1/8)	2
1	6103-14	Suspension Seat	1	45	8038-1	Spacer, Tail Wheel Axle	2
2	6103-35	Suspension Seat Mount	2	46	8037	Bearing Cone (3/4 ID)	4
3	7440-7	Shock Mount	4	47	8035	Tail Wheel & Tire Assembly (13 x 5.00-6)	2
4	6105-1	Shoulder Washer	2			(With Bearing Race)	
<b>Rear Bumper Assembly</b>					7035-1	Tail Wheel Tire (13 x 5.00-6)	*
5	7516-7	GHS Rear Bumper	1		8036	Wheel & Hub (6 x 3.25)	*
6	7516-5	Catcher Pivot Bushing	2			(Includes Items # 42 & Bearing Race)	
7	5162	Roller Wheel (5" Rubber)	2		8037-2	Bearing Race	*
8	7517-2	Catcher Pivot Plate	2	48	8768-2	Seal, Reverse Lip	2
<b>Body Assembly</b>				49	8038	Tail Wheel Axle (3/4 x 10-3/8)	1
9	8531-19	Heat Guard	1	50	7070	Wheel & Tire Assembly (18 x 9.50-8)	2
10	8531-4	Body Grass Shield (Includes Items # 9 & F362)	1		7070-1	Drive Tire (18 x 9.50-8)	*
11	7833-2	Cable Clamp (1 x 1/4)	1		5070-4	Wide Wheel (8 x 7)	*
12	5977-3	Grommet (9/16)	1	51	8300-17	Chassis Frame	1
13	NS	Body ID Plate	1	<b>Fasteners</b>			
14	5845	Rubber Bumper (1.50 OD x 1.25)	4		F002	10-24 Keps Nut	3
15	8118	Heat Deflector	1		F004	1/4-20 Keps Nut	5
16	7422	Panel Guard	1		F005	1/4-20 ESNA Nut	1
17	5989-4	Dome Plug (3/8)	4		F009	5/16-18 Whiz Locknut	16
18	5989-3	Dome Plug (5/16)	2		F012	3/8-16 Keps Nut	8
19	6105-3	Harness Clip	2		F013	3/8-16 Whiz Locknut	2
20	7146	13mm Ball Stud	2		F014	3/8-16 ESNA Nut	4
21	7145	Gas Spring Assembly (Includes Item # 20)	1		F020	5/16-18 ESNA Nut	1
22	7844	Rubber Bumper (1.25 OD x .250)	1		F025	10-24 x 3/8 PPHMS	3
23	7383-3	Body Latch Hook (2-1/2 Side Bars)	1		F029	1/4-20 x 1/2 Hex Bolt	2
24	7222	Extension Spring (1/4 x 3)	1		F031	1/4-20 x 5/8 Hex Bolt	4
25	7854	Plastic Tip, Red	1		F034	5/16-18 x 3/4 Hex Bolt	2
26	5989-9	Dome Plug (1/4)	8		F038	3/8-16 x 1 Hex Bolt	6
27	5180	Edge Molding, Lever Opening	2		F040	3/8-16 x 1-1/2 Hex Bolt	2
28	8100-7	Front Body	1		F042	3/8-16 x 2-1/4 Hex Bolt	2
29	5989-55	Dome Plug (1/2)	1		F050	1/4 SAE Washer	4
30	5989-5	Dome Plug (7/16)	1		F051	3/8 SAE Washer	2
<b>Tilt-Up Latch Assembly**</b>					F059	3/8 Wave Spring Washer	2
31	5847	Plastic Tip	1		F093	5/16-18 x 1 Hex Bolt	1
32	5744-20	Spring Arm, Tilt-Up Latch	1		F151	3/8-16 x 7/8 Hex Bolt	2
33	5744-10	Spring Pivot Bushing	1		F157	1/2-20 x 1-1/4 Wheel Lug Bolt	8
34	5744-15	Compression Spring (3/8 x 5/8)	1		F191	3/8 x 1-1/2 x 3/16 Washer	2
35	5744-13	Mount Angle, LH	1		F205	5/16-18 x 1/4 Set Screw, Knurl Point	2
36	5744-12	Hook, Tilt-Up Latch	1		F206	#2 x 3/16 Drive Pin	2
37	5744-14	Mount Angle, RH	1		F218	7/16 Split Lock Washer	2
<b>Chassis Assembly</b>					F219	7/16-14 x 1-1/4 Hex Bolt	2
38	5267-1	Retainer Collar (1") (Includes Item # F413)	1		F241	.375 x .875 x .10 Washer	4
39	5270-1	Pivot Bearing	2		F341	Coil Roll Pin (7/64 x 9/16)	1
40	5842-1	Washer (1.0 ID x 1.350 OD)	1		F342	5/16 Conical Washer	2
41	7420	Tail Wheel Fork	1		F362	A/A62D Alum. Pop Rivet (3/16 D x 13/32 L)	6
42	5830-3	Grease Fitting (45 Degree)	2		F413	5/16-24 x 5/16 Set Screw	2
43	8039	Nut, Tail Wheel Axle	2		F429	5/16-18 x 1/2 SFH Screw	4
				*	Service Part Only		
				**	Complete Tilt-Up Latch Assembly Kit available by ordering kit # 5747.		

Beginning S/N 124884

Effective Date 10-07-13

Use only genuine **Walker**® replacement parts.

# BODY / CHASSIS ASSEMBLY

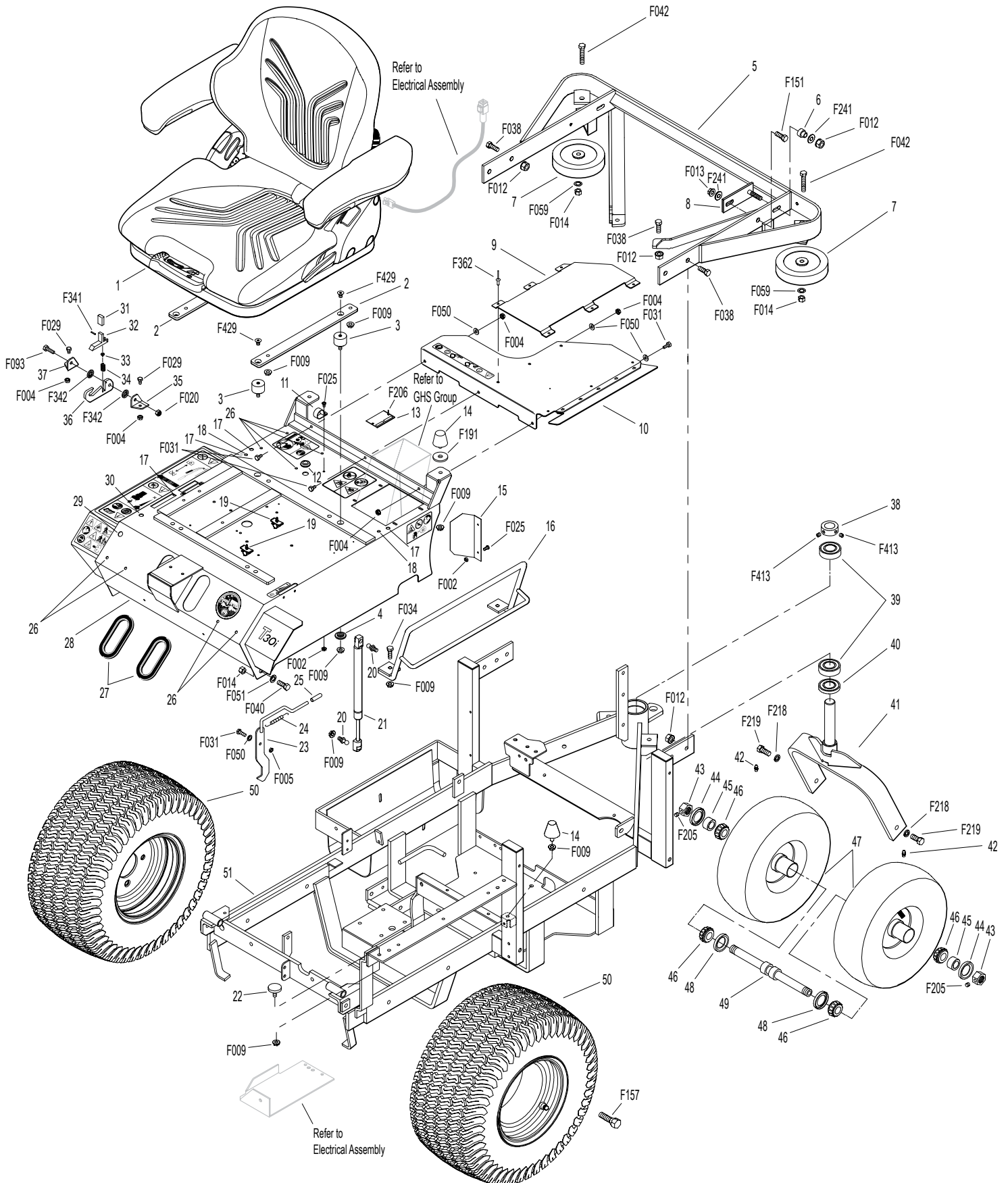

Beginning S/N 124884  
 Effective Date 10-07-13  
 Use only genuine Walker® replacement parts.

# REAR BODY ASSEMBLY

ITEM NO.	PART NO.	DESCRIPTION	NO. REQ'D	ITEM NO.	PART NO.	DESCRIPTION	NO. REQ'D
<b>Rear Body Assembly</b>				<b>Fasteners</b>			
1	8515-13	Catcher Handle Plate, LH	1	F002		10-24 Keps Nut	12
2	8515-14	Catcher Handle Plate, RH	1	F004		1/4-20 Keps Nut	5
3	8615-4	Catcher Support Frame, 10.0	1	F009		5/16-18 Whiz Locknut	2
4	7190-2	Insulation Foam Pad, RH	1	F025		10-24 x 3/8 PPHMS	5
5	7190-1	Insulation Foam Pad, LH	1	F026		10-24 x 1/2 PPHMS	7
6	5832	Cable Clamp (1/2)	1	F027		10-24 x 5/8 PPHMS	1
7	8389-3	Splash Guard	1	F031		1/4-20 x 5/8 Hex Bolt	2
8	7145	Gas Spring Assembly (Includes Items # 9 & 10)	1	F032		1/4-20 x 3/4 Hex Bolt	1
9	7147	Spring Clip	2	F085		3/16 Rivet Backup Washer	3
10	7146	13mm Ball Stud	2	F178		1/4 x 1 Fender Washer	1
11	8082-2	Heat Shield, 10.0	1	F390		1/4-20 x 7/8 Carriage Bolt	2
12	7190-4	Insulation Foam Pad / GHS	1	<b>NOTE:</b> Rear Bumper Assembly for GHS Models is not shown here. Refer to <b>BODY / CHASSIS ASSEMBLY</b> , Page 4.			
13	8105-16	Rear Body Panel	1				



# REAR BODY ASSEMBLY

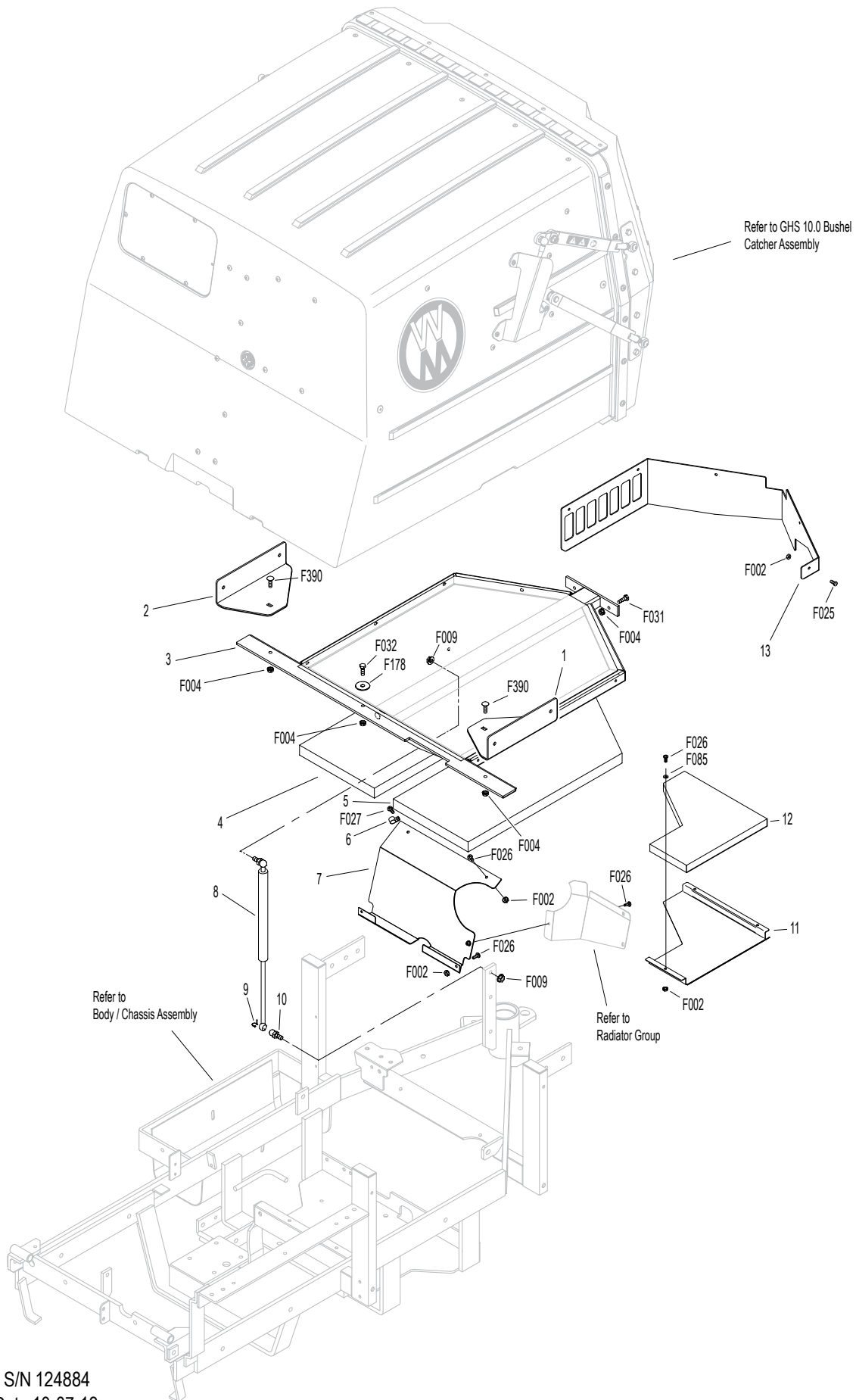

Beginning S/N 124884  
Effective Date 10-07-13  
Use only genuine **Walker**® replacement parts.

# MAIN COMPONENT POWER TRANSMISSION

ITEM NO.	PART NO.	DESCRIPTION	NO. REQ'D	ITEM NO.	PART NO.	DESCRIPTION	NO. REQ'D
<b>Clutch Lever Assembly</b>				41	8349-3	Idler Arm	1
1	8358-3	Clutch Lever (Includes Items # 2 & 3)	1	42	6325-4	Spacer Bushing (3/16)	1
2	5830	Grease Fitting	7	43	7201-4	Inner Race (1-1/2)	2
3	4850	Handle Grip, Black	1	44	5221-1	Extension Spring (3/4 x 5)	2
4	7303-10	Clutch Actuator Bolt (3/8)	1	45	8539	Starter Relay Mount	1
5	7380-5	Knuckle Joint (3/8 ID)	1	46	5268	Bearing W/Collar (3/4)	2
6	7226-10	Compression Spring (3/4 x 2-1/2)	1	47	7241-2	Transmission Drive Pulley (3-1/4MV) (Includes Items # F067 & F171)	1
7	8130-5	Pushrod, Clutch Actuator (Threaded Tube) (Includes Item # 2)	1	48	7833	Cable Clamp (7/8 x 1/4)	1
8	8130-10	Clutch Actuator Rod Assembly (Includes Items # 2, 4-7, F054, F336 & F353)	1	49	8349	Transmission Belt Tightener Arm	1
9	7201-3	Fiberglide Bearing	6	50	6325-2	Spacer Bushing (5/16)	1
10	7201-5	Inner Race (2-1/4)	1	51	8394-1	Hydro Jackshaft Mount Assembly (Includes Items # 2, 9, 43, 46, 51 & 52)	*
11	8368	PTO Belt Tightener	1	52	8273	Jackshaft (3/4 x 7-1/2)	1
12	5841	Retainer Washer (3/8 x 1-1/4)	4	53	7240-4	Jackshaft Drive Pulley (3.3/3V) (Includes Items # F067 & F171)	1
13	8243-1	Clutch Idler Pulley	1	<b>Fasteners</b>			
	8243	Clutch Idler Pulley Assembly (Includes Items # 13-15 & F070)	*	F003	1/4-28 Hex Nut		2
14	5265	Bearing (3/4)	1	F004	1/4-20 Keps Nut		3
15	8243-3	Hub, Idler Pulley	1	F005	1/4-20 ESNA Nut		1
16	8375	PTO Belt Tightener Stop	1	F009	5/16-18 Whiz Locknut		3
17	7377	Plastic Washer (1 x .438 x .025)	2	F012	3/8-16 Keps Nut		7
18	7378	Pivot Bearing (7/16 x 9/16)	1	F029	1/4-20 x 1/2 Hex Bolt		1
19	5281-1	Clevis Spring Pin	1	F040	3/8-16 x 1-1/2 Hex Bolt		1
20	5280	Clevis (1/4)	2	F041	3/8-16 x 1-3/4 Hex Bolt		2
21	8305	Brake Actuator Rod	1	F042	3/8-16 x 2-1/4 Hex Bolt		3
22	8370	Bearing, Brake Actuator	1	F043	3/8-16 x 3 Hex Bolt		1
23	5281-5	Clevis Pin (1/4 x 0.80)	1	F047	3/8-16 x 4-1/2 Hex Bolt		1
24	8250	Brake Spring (1/2 x 2-1/2)	1	F054	AN960616 Washer		3
25	8369	Brake Actuator (Includes Items # 2 & 22)	1	F061	1/4 Internal Star Lock Washer		1
<b>PTO Drive Shaft Assembly</b>				F067	3/16 x 3/16 x 1 Key		2
26	7050-1	Dipstick, Gearbox	1	F069	3/32 x 1/2 Cotter Pin		1
27	8371-1	Mount Bracket, Brake Band	1	F070	1-3/4 Internal Snap Ring		1
28	8377	Brake Band Guide	1	F090	1/4-20 x 2-1/2 Hex Bolt		1
29	8050-11	PTO Gearbox / Flange Pulley	1	F116	1/4-20 x 1-1/4 Hex Bolt		1
30	5245	Idler Pulley (3")	2	F121	5/16-18 x 3/8 x 1 SHL Bolt		1
31	7248	Ground Drive Belt, Micro-V	1	F131	5/16-18 x 1/2 Hex Bolt		2
32	7275-16	Universal Joint Tube Assembly / Spline	1	F132	1/4-20 x 2-3/4 Hex Bolt		1
33	7275-9	Quick Coupler Installation Tool	1	F168	5/16 Split Lock Washer		14
34	7523-2	Clevis Pin W/Hole (1/4 x 5/8)	1	F171	5/16-18 x 3/8 Set Screw		4
35	8304	Brake Band (14-1/2)	1	F178	1/4 x 1 Fender Washer		1
36	6250-1	Drive Belt (3VX370)	1	F182	1/4 x 5/8 x 1/8 Washer		2
37	7236-1	PTO Drive Pulley (4-1/2/3V) (Includes Items # F168 & F226)	1	F186	5/64 x 1/2 Cotter Pin		1
38	8237-2	Engine Pulley, Bolt On (4/3.8/3V) (Includes Items # F168 & F226)	1	F226	5/16-18 x 7/8 Hex Bolt		14
39	8230	Engine PTO Belt	1	F241	.375 x .875 x .10 Washer		1
<b>Jackshaft Assembly</b>				F255	5/16-18 x 1-1/2 Hex Bolt		2
40	7245-1	Idler Pulley (3/8 Groove)	1	F261	AN960616L Washer		1
				F336	3/8-16 Jam Nut		1
				F353	3/8-16 ESNA LP Nut		1
				*	Service Part Only		

Beginning S/N 124884

Effective Date 10-07-13

Use only genuine **Walker**® replacement parts.

# MAIN COMPONENT POWER TRANSMISSION

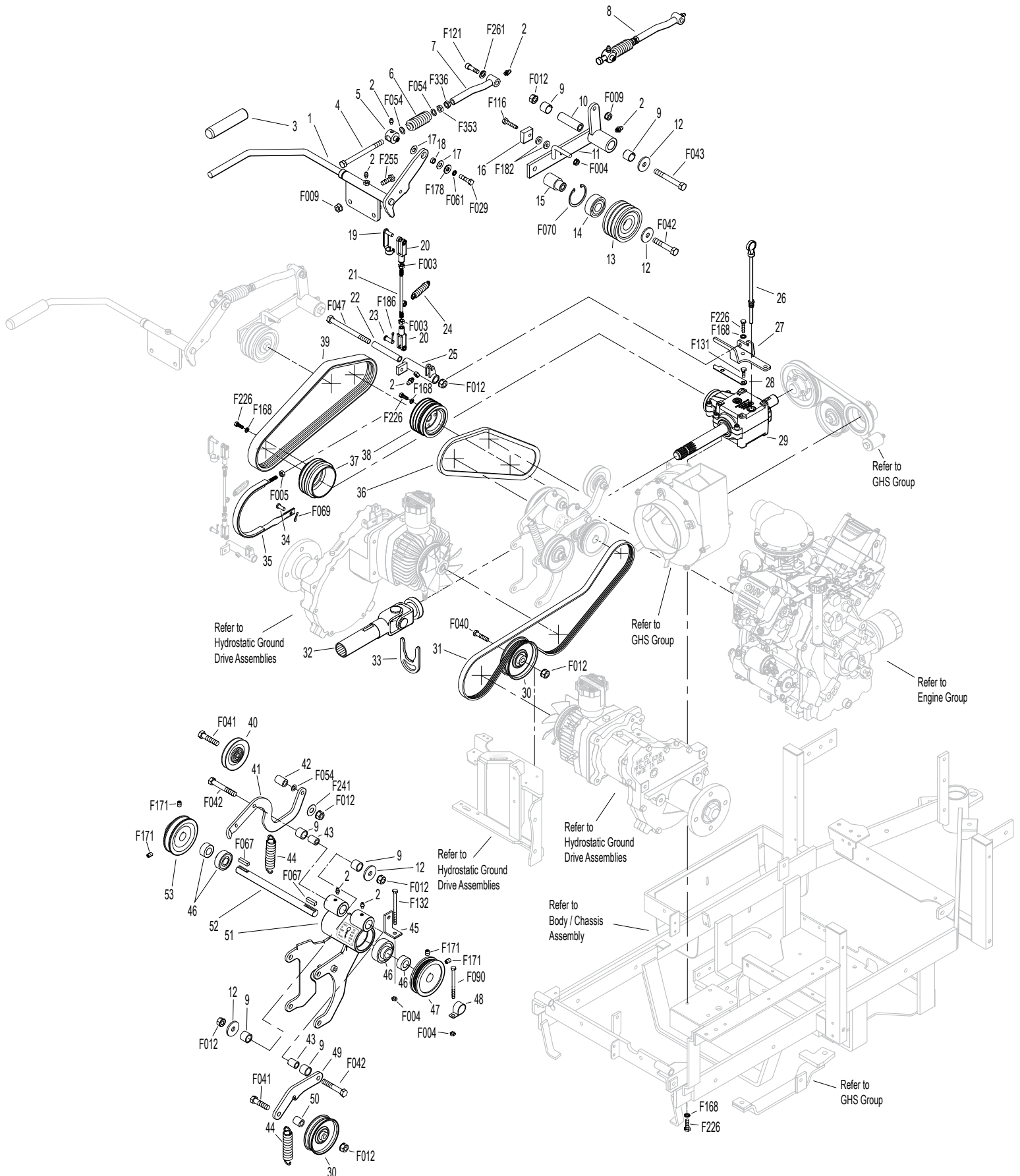

Beginning S/N 124884  
 Effective Date 10-07-13  
 Use only genuine **Walker**® replacement parts.

# ENGINE GROUP

ITEM NO.	PART NO.	DESCRIPTION	NO. REQ'D	ITEM NO.	PART NO.	DESCRIPTION	NO. REQ'D
<b>Precleaner Assembly</b>				31	8533-3	Muffler Base Shield	1
1	7026-2	Remote Precleaner (Includes Item # 5)	1	32	8533-4	Muffler Shield	1
2	7440	Shock Mount (1 x 3/4)	3	33	8318-3	Engine Brace	1
3	7028-20	Rear Precleaner Mount	1	34	8531-10	Rear Muffler Heat Shield	1
4	7032	Elbow, Precleaner	1	35	NS	Oxygen Sensor (Kohler)	1
5	7840-5	Hose Clamp (1-1/2 to 2)	5	36	NS	Gasket (Kohler)	2
6	5091-2	Air Flow Indicator (Vacuum 10" H2O)	1	37	NS	Nut (Kohler)	4
7	5091-4	Indicator Nipple	1	<b>Fasteners</b>			
8	5088-12	Air Cleaner Assembly (Includes Items # 6, 7 & 10-14)	*	F002	10-24 Keps Nut		4
9	5088-1	Air Cleaner Band	1	F004	1/4-20 Keps Nut		3
10	5090-3	Safety Filter Insert	1	F009	5/16-18 Whiz Locknut		9
11	5090-1	Air Cleaner Cartridge	1	F012	3/8-16 Keps Nut		8
12	5088-5	Air Cleaner Draw Latch	2	F025	10-24 x 3/8 PPHMS		1
13	5088-11	Air Cleaner Cap (Includes Item # 12)	1	F028	10-24 x 3/4 PPHMS		2
14	5090-2	Vacuator Valve	1	F032	1/4-20 x 3/4 Hex Bolt		3
15	8026-10	Air Hose, Cleaner	1	F038	3/8-16 x 1 Hex Bolt		3
16	7031-2	Tube Support Arm	1	F041	3/8-16 x 1-3/4 Hex Bolt		4
17	7028-6	Precleaner Tube, 1-3/4 GHS	1	F050	1/4 SAE Washer		2
<b>Engine Assembly</b>				F051	3/8 SAE Washer		4
18	7306-15	Water Temperature Sender	1	F053	7/16 Internal Star Lock Washer		2
19	7306-12	Temperature Sender Adapter	1	F061	1/4 Internal Star Lock Washer		1
20	NS	Oil Filter (Kohler 1205001)	1	F063	3/8 Internal Star Lock Washer		1
21	NS	30 HP Kohler EFI Engine	1	F091	5/16-18 x 5/8 Hex Bolt		4
22	8016-2	Regulator Mount	1	F128	10-24 x 3/8 PTHMS		1
23	NS	Screw (Kohler)	1	F129	10-24 x 1/2 PTHMS		4
24	NS	Regulator (Kohler)	1	F132	1/4-20 x 2-3/4 Hex Bolt		1
<b>Exhaust Assembly</b>				F140	7/16-14 x 1 Hex Bolt		2
25	5665	Compression Spring (1/2 x 1)	2	F151	3/8-16 x 7/8 Hex Bolt		1
26	8013-38	Muffler	1	F187	1/4-20 x 1-1/2 Hex Bolt		2
27	8532-5	Upper Grass Shield	1	F188	1/4-20 Self-Locking Nut		2
28	8532-2	Rear Shield	1	F396	10-24 x 1-1/4 PPH Bolt		1
29	8530-15	Muffler End Shield	1	F511	M5 x 20MM Thread Forming Screw		1
30	8533-2	Top Shield	1	* Service Part Only			

**NOTE:** Refer to Kohler Engine Decal (NS) for Engine Identification Numbers.

# ENGINE GROUP

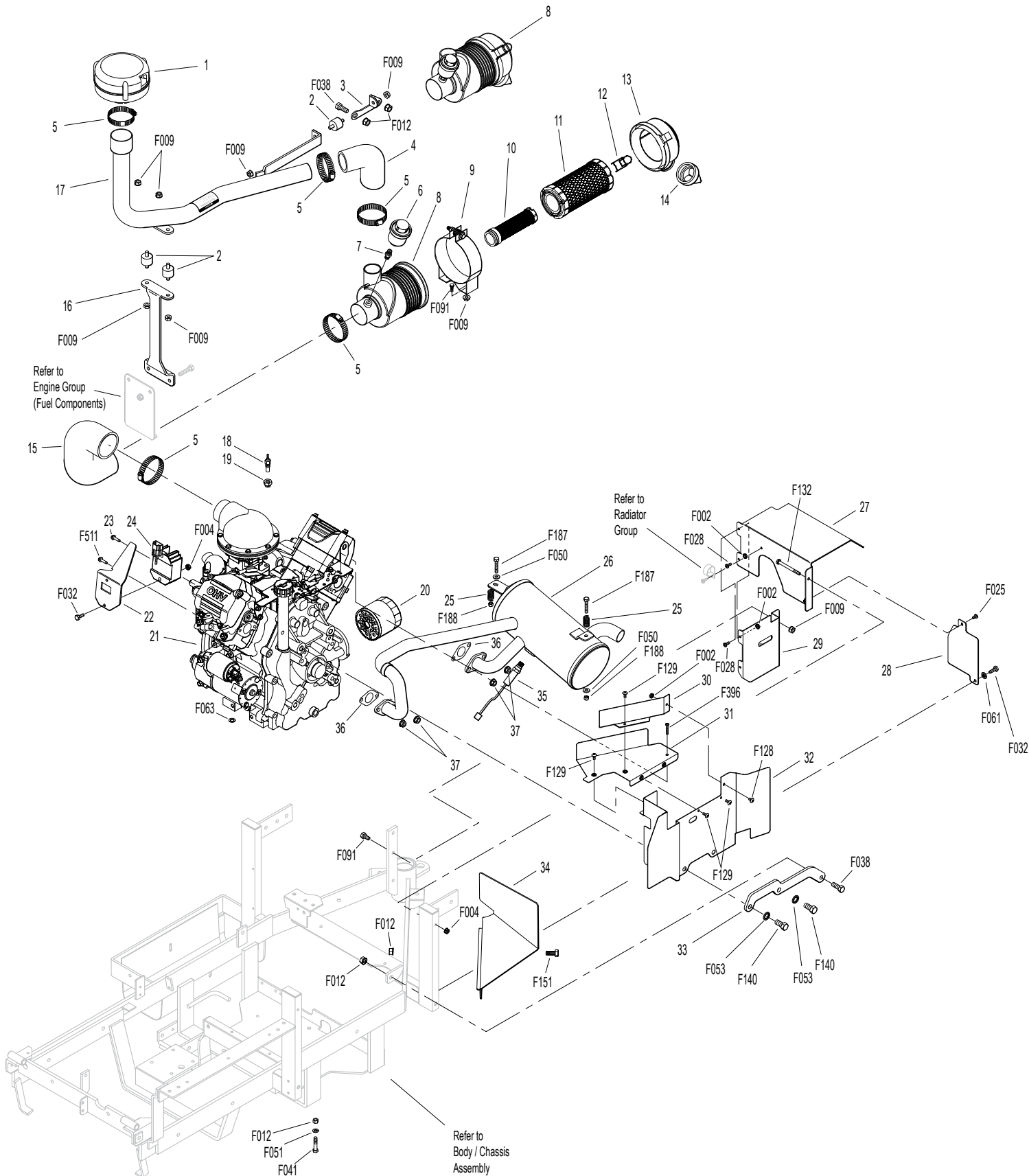

Beginning S/N 124884  
 Effective Date 10-07-13  
 Use only genuine Walker® replacement parts.

## ENGINE GROUP (FUEL COMPONENTS)

ITEM NO.	PART NO.	DESCRIPTION	NO. REQ'D	ITEM NO.	PART NO.	DESCRIPTION	NO. REQ'D
<b>Fuel Tank Assembly</b>				27	5082-4	2-1/4 Ratchet Fuel Cap	1
1	7046-1	Fuel Return Tube	1	28	8055-2	Fuel Tank Gauge	1
2	5879-3	Hose Clamp (1/2)	2	29	5977-7	Roll Over Grommet (.900 x 1-1/2)	1
3	M111	Fuel Line (1/4 x 16")	1*	30	8043-8	Roll Over Valve	1
4	M247	Fuel Line (5/16 x 21") Regulator To Filter (Includes Item # 5)	1*	31	M113	Fuel Line (3/16 x 15")	1*
5	5879-5	Stepless Ear Clamp (5/8)	7	32	5975-1	Cable Tie (18# x 3-3/4")	1
6	8026-14	Clamp, Loop Style	1	33	5083-1	Bushing, Rubber	1
7	NS	Fuel Filter (Kohler)	1	<b>Fasteners</b>			
8	M247	Fuel Line (5/16 x 26") Filter to Engine	1*	F002	10-24 Keps Nut		6
9	M247	Fuel Line (5/16 x 16") Pump To Regulator	1*	F004	1/4-20 Keps Nut		4
10	M113	Vent Tube, Regulator (3/16 x 4")	1*	F009	5/16-18 Whiz Locknut		4
11	NS	Fuel Regulator (Kohler)	1	F025	10-24 x 3/8 PPHMS		1
12	7014-8	Regulator / Filter Mount	1	F026	10-24 x 1/2 PPHMS		7
13	7833	Cable Clamp (7/8 x 1/4)	1	F029	1/4-20 x 1/2 Hex Bolt		4
14	NS	Fuel Pump (Kohler)	1	F031	1/4-20 x 5/8 Hex Bolt		2
15	NS	Clamp (Kohler)	2	F034	5/16-18 x 3/4 Hex Bolt		2
16	7014-5	Fuel Pump Mount (Includes Items # F002 & F004)	1	F061	1/4 Internal Star Lock Washer		2
17	7014-6	Fuel Pump Cover	1	F255	5/16-18 x 1-1/2 Hex Bolt		2
18	5832	Cable Clamp (1/2)	1	<b>* Required hose specifications:</b>			
19	8023	Fuel Tank Support	1	M111 - 1/4" ID fuel/oil/vapor hose (Gates 4219-0103 or equivalent)			
20	M247	Fuel Line (5/16 x 8") Tank to Pump	1*	M113 - 3/16" ID fuel/oil/vapor hose (Gates 4219-0093 or equivalent)			
21	7014-7	Fuel Line Guard	1	M247 - 5/16" ID low permeation (<15g/m <sup>2</sup> /day) fuel hose (Parker 38905 or equivalent)			
22	5083-2	Tank Tube Elbow	1	<b>NOTE:</b> Refer to Kohler Engine Decal (NS) for Engine Identification Numbers.			
23	5083-4	Plug Bushing (Viton)	1				
24	5086-7	Hose (1/4 x 6")	1				
25	5020-2	Fuel Filter, In Tank	1				
26	8055-1	Fuel Tank, 4.7 Gallon, Gas (Black) (Includes Items # 1, 23-25, 28-30 & 33)	1				

# ENGINE GROUP (FUEL COMPONENTS)

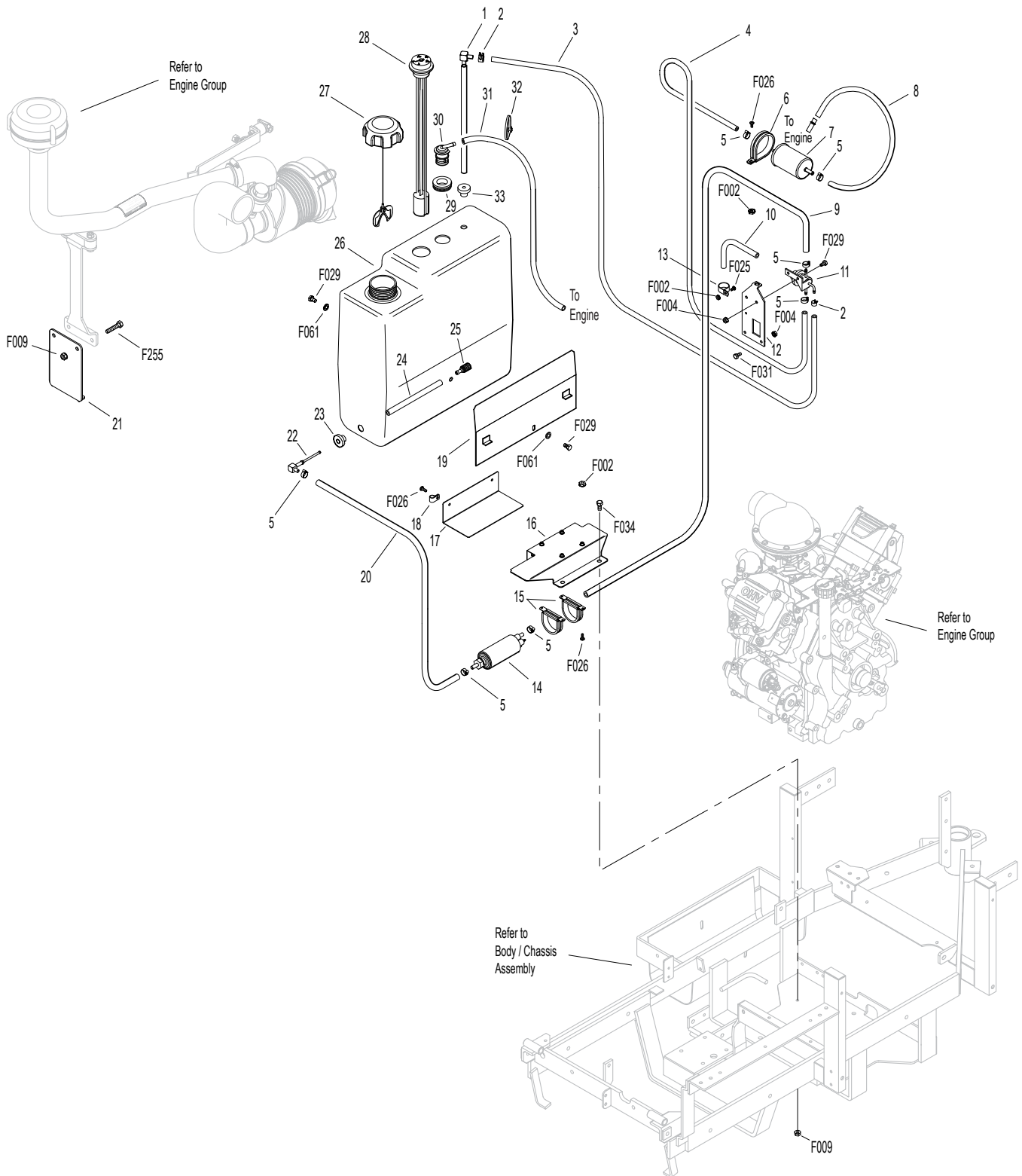

# RADIATOR GROUP

ITEM NO.	PART NO.	DESCRIPTION	NO. REQ'D	ITEM NO.	PART NO.	DESCRIPTION	NO. REQ'D
<b>Radiator Assembly</b>				<b>Fasteners</b>			
1	7017-12	Upper Radiator Hose, RH	1	F002		10-24 Keps Nut	6
2	7840-3	Hose Clamp (1/2 to 1-1/4)	4	F004		1/4-20 Keps Nut	4
3	8531-13	Tee Coupling	1	F014		3/8-16 ESNA Nut	2
4	7833-2	Cable Clamp (1 x 1/4)	2	F025		10-24 x 3/8 PPHMS	2
5	7017-11	Upper Radiator Hose, LH	1	F026		10-24 x 1/2 PPHMS	3
6	8123-2	Insultherm (1 x 6)	1	F028		10-24 x 3/4 PPHMS	1
7	7840-4	Hose Clamp (3/4 to 1-1/2)	2	F029		1/4-20 x 1/2 Hex Bolt	5
8	7017-6	Lower Radiator Hose	1	F031		1/4-20 x 5/8 Hex Bolt	6
9	7432	Shock Mount (1.00 OD x .75)	1	F032		1/4-20 x 3/4 Hex Bolt	6
10	7426-3	Rubber Isolator Mount	1	F061		1/4 Internal Star Lock Washer	14
11	7426-5	Screen Channel	2	F073		1/4 x 1.5 Fender Washer	2
12	7426-7	Radiator Brace	1	F129		10-24 x 1/2 PTHMS	4
13	7425	Radiator Screen	1	F132		1/4-20 x 2-3/4 Hex Bolt	2
14	7426-8	Screen Stop	2	F360		1/4-20 x 3/8 Hex Bolt	1
15	7431-2	Radiator Channel Seal	2				
16	7427-9	Radiator Cap	*				
17	7427-13	Radiator	1				
18	7426-6	Radiator Fan Shroud	1				
19	7427-22	Fan Mount Tab, RH	2				
20	7429-6	Radiator Cooling Fan	*				
21	7429-7	Fan Blade Replacement	*				
22	7427-21	Fan Mount Tab, LH	2				
23	8531-7	Rear Shield	1				
24	8531-6	Lower Shield	1				
25	7430-5	Radiator Guard	1				
26	7426-4	Radiator Mount	1				
27	7434	Washer (3/8 x 1-1/4 x 1/4)	4				
28	5841	Retainer Washer (3/8 x 1-1/4)	2				
29	7427-3	Coolant Recovery Tank	1				
30	7427-10	Recovery Tank Mount	1				
31	7427-11	Recovery Tank Keeper	1				
32	7015-13	Recovery Tank Hose (25")	1				
33	5975-3	Cable Tie (50# x 7")	3				
				*		Service Part Only	



# RADIATOR GROUP

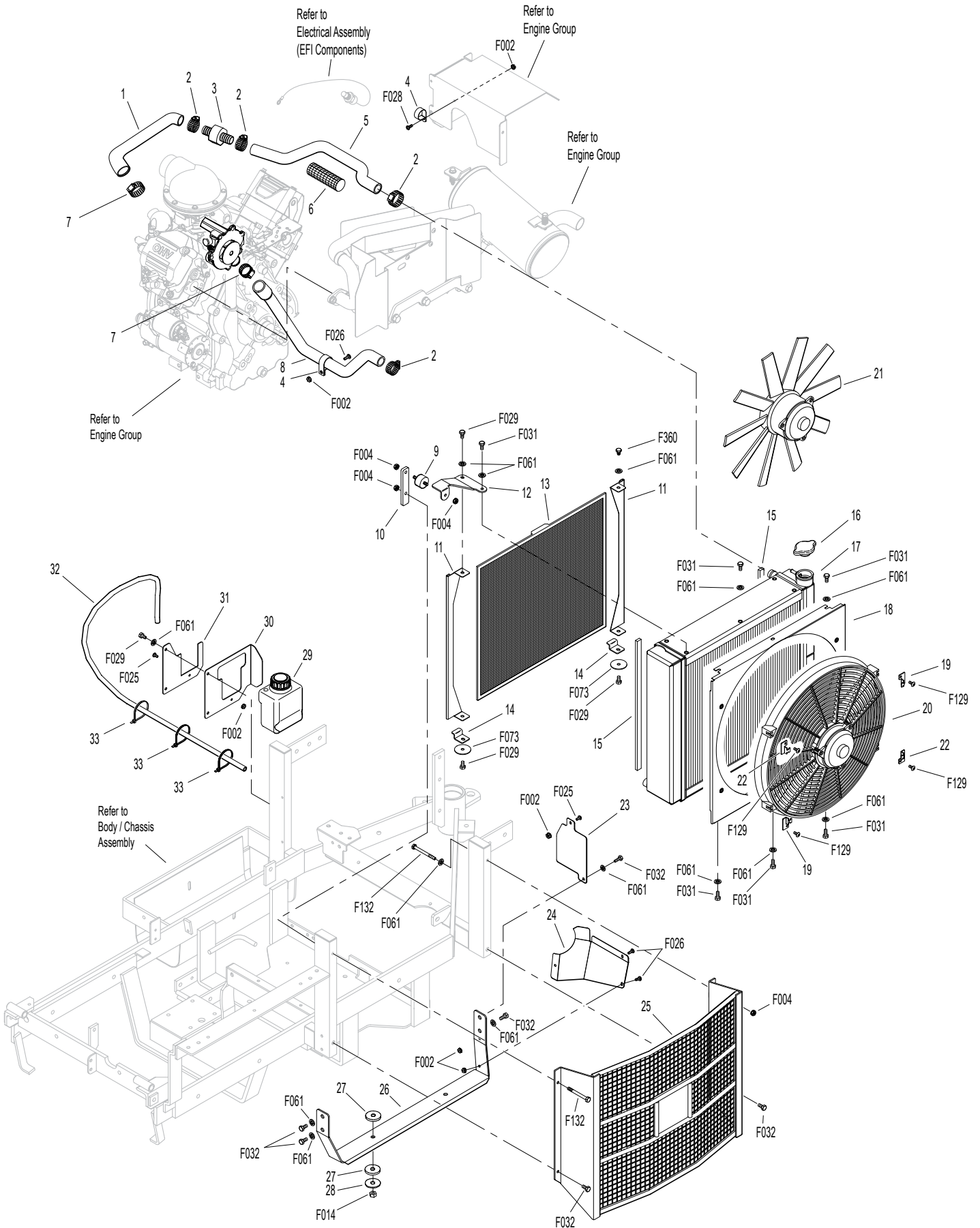

Beginning S/N 124884  
 Effective Date 10-07-13  
 Use only genuine Walker® replacement parts.

# HYDROSTATIC GROUND DRIVE ASSEMBLIES

ITEM NO.	PART NO.	DESCRIPTION	NO. REQ'D	ITEM NO.	PART NO.	DESCRIPTION	NO. REQ'D
<b>Transmission Lockout Assembly</b>				<b>Transmission Repair Parts</b>			
1	5028-3	Transmission Lockout Assembly (Includes Items # 2-5, F023, F027 & F081)	*	26	5025-5	Input Shaft	*
2	5847	Plastic Tip	2	27	5025-8	Bearing, Input Shaft	*
3	5057	Lockout Cam (Includes Item # F081)	2	28	5025-7	Snap Ring	*
4	5028-5	Lockout Lever	2	29	5025-2	Seal, Input Shaft	*
5	5027-5	Lockout Mount	1**	30	5022	Reservoir to Casting Gasket	*
<b>Ground Drive Assemblies</b>				31	5024	Reservoir Cap and Gasket	*
6	6209-4	Bridge Assembly	1	32	5023	Transmission Reservoir Kit	*
7	6243-2	Hydro Fan, CCW	1	33	5023-1	Rubber Bladder	*
8	5026	Hydrostatic Drive, CW (700-051)	1	34	5025-6	O-Ring & Plug Assembly	*
9	6206-1	Air Vent Valve	*	35	5025-3	Seal, Control Shaft	*
10	6200-9	Gear Axle Drive Assembly (Includes Items # 9 & 11)	2	<b>Fasteners</b>			
11	6207-12	Pipe Plug (1/4 NPTF)	4	F012	3/8-16 Keps Nut		2
12	5126	Cable Retainer (Uses existing bolt on Gear Axle Drive Assembly)	1	F023	10-24 ESNA Nut		2
13	6233-1	Pinion Gear	2	F027	10-24 x 5/8 PPHMS		2
14	6234	Spacer, Pinion Gear	2	F036	1/4-20 x 1/2 SBH Screw		2
15	6201	O-Ring Seal	2	F038	3/8-16 x 1 Hex Bolt		4
16	7244	Hydro Pulley (3-7/8/MV) (Includes Items # F064 & F359)	2	F040	3/8-16 x 1-1/2 Hex Bolt		4
17	6243-1	Hydro Fan, CW	1	F043	3/8-16 x 3 Hex Bolt		6
18	5025	Hydrostatic Drive, CCW (700-052)	1	F053	7/16 Internal Star Lock Washer		4
<b>Deck Support Arm Assemblies</b>				F063	3/8 Internal Star Lock Washer		14
19	6430-10	Outboard Mount, LH	1	F064	1/8 x 1/2 Woodruff Key (#3)		4
20	6431-1	Deck Support Arm, LH (Includes Item # 24)	1	F081	A/A45D Aluminum Pop Rivet		2
21	5775-2	Hitch Pin (# 6)	2	F160	External Snap Ring (.669 Shaft)		2
22	6431-2	Deck Support Arm, RH (Includes Item # 24)	1	F178	1/4 x 1 Fender Washer		2
23	6430-9	Outboard Mount, RH	1	F194	7/16 x 1-1/4 x 1/8 Washer		2
24	5830	Grease Fitting	2	F200	7/16-20 x 3 Grade 8 Bolt		2
25	6840-1	Support Arm Bushing (2-1/16)	2	F244	7/16-20 x 3/4 Hex Bolt		2
				F262	3/8-16 x 4 Hex Bolt All Thread		2
				F359	5/16-18 x 5/16 Set Screw (Unbrako Knurl Point)		4
				* Service Part Only			
				** Part not used on Jackshaft side of tractor.			



# STEERING CONTROL ASSEMBLIES

ITEM NO.	PART NO.	DESCRIPTION	NO. REQ'D	ITEM NO.	PART NO.	DESCRIPTION	NO. REQ'D
<b>Transmission Spring Assemblies</b>				30	5470-1	Speed Control Stop	1
1	6201-2	Shock Mount Gear Drive, RH	1	31	5450-10	Steering Lever Assembly, RH / Adjustable (Includes Items # 9, 10, 16, F360 & F489)	1
2	5146	10mm Ball Stud	4		5450-7	Steering Lever Arm, RH / Adjustable	*
3	5199-3	Steering Lever Dampener Assembly	2	32	5862	FSC Knob	1
4	6201-1	Shock Mount Gear Drive, LH	1	33	7170	FSC Lever Assembly (Includes Item # 16)	1
5	5214-2	Ball Joint (5/16-24) Nylon Lined	2	34	5975-3	Cable Tie (50# x 7")	1
6	6212-1	Transmission Control Arm, LH	1	<b>Fasteners</b>			
7	5213-3	Control Rod (6")	1		F003	1/4-28 Hex Nut	1
8	5665-1	Compression Spring (2-1/2)	2		F004	1/4-20 Keps Nut	6
9	5463-2	Steering Lever Actuator	2		F007	5/16-18 Jam Nut	1
10	7201-2	Fiberglide Bearing 1/2"	2		F008	5/16-24 Keps Nut	2
11	5213-4	Control Rod (14-3/4")	1		F009	5/16-18 Whiz Locknut	5
12	5212	Transmission Control Arm, RH	1		F010	5/16-24 ESNA Nut	2
<b>Steering Lever &amp; FSC Assemblies</b>					F024	5/16-24 Jam Nut	2
13	5173	FSC Actuator Rod	1		F029	1/4-20 x 1/2 Hex Bolt	2
14	5172	Bearing, Delrin (.255 ID x .379 OD x .250)	1		F032	1/4-20 x 3/4 Hex Bolt	4
15	5142-2	FSC Actuator Cam	1		F034	5/16-18 x 3/4 Hex Bolt	1
16	5830	Grease Fitting	6		F050	1/4 SAE Washer	3
17	5141	FSC Friction Washer (1-1/2 x 3/8 x 1/16)	2		F051	3/8 SAE Washer	2
18	5140-15	FSC Friction Body (Includes Item # 16)	1		F064	1/8 x 1/2 Woodruff Key (#3)	2
19	5142-7	FSC Key W/Stop	1		F068	1/8 x 1 Cotter Pin	1
	5140-13	FSC Control Assembly (Includes Items # 15-19, F192 & F193)	*		F069	3/32 x 1/2 Cotter Pin	1
20	5850-2	Handle Grip, Foam (5-1/2)	2		F093	5/16-18 x 1 Hex Bolt	1
21	5223	Extension Spring (1/4 x 5-1/2)	2		F183	.312 x .700 x .074 Washer	2
22	5450	D-Clip	2		F186	5/64 x 1/2 Cotter Pin	1
23	5391-3	Steering Lever Support	1		F188	1/4-20 Self-Locking Nut	4
24	5217	Pivot Pin, Steering Lever	1		F192	3/8-24 Self-Locking Nut	1
25	5451-10	Steering Lever Assembly, LH / Adjustable (Includes Items # 9, 10, 16, F360 & F489)	1		F193	3/8 Belleville Spring Washer	3
	5451-7	Steering Lever Arm, LH / Adjustable	*		F198	.250 x .625 x .040 Washer, SS	2
26	5453-20	Steering Lever Handle +1" Adjustable / SS (Includes Items # 20, F188, F198 & F345)	2		F345	1/4-20 x .770 Knurled Bolt	4
27	5219	Extension Spring (3/4 x 6-3/4)	1		F353	3/8-16 ESNA LP Nut	2
28	5280	Clevis (1/4")	1		F360	1/4-20 x 3/8 Hex Bolt	2
29	5281-5	Clevis Pin (1/4 x 0.80)	1		F401	.504 x .751 x .030 Washer	1
					F489	Washer 1/4 x 7/8 x .090	2
				* Service Part Only			



# THROTTLE CONTROL ASSEMBLY

ITEM NO.	PART NO.	DESCRIPTION	NO. REQ'D	ITEM NO.	PART NO.	DESCRIPTION	NO. REQ'D
<b>Throttle Control Assembly</b>				<b>Fasteners</b>			
1	8108-3	Throttle Cable	1	F002		10-24 Keps Nut	2
2	5172	Bearing, Delrin (.255 x .379 x .250)	1	F005		1/4-20 ESNA Nut	1
3	5108-7	Control Lock Tab	1	F025		10-24 x 3/8 PPHMS	2
4	5108-10	Friction Washer (.125)	1	F050		1/4 SAE Washer	1
5	5108-1	Control Lever, Throttle & Choke	1	F129		10-24 x 1/2 PTHMS	1
6	5108-5	Throttle Control Knob, Red	1	F145		4-40 Keps Nut	2
7	5108-11	Friction Washer (.062)	1	F164		10-24 x 1/4 x 3/8 SHL Bolt	1
8	5108-8	Control Bracket	1	F201		1/4 Belleville Spring Washer	2
9	7108	Control Assembly	1	F491		4-40 x 3/8 PPHMS	2
		(Includes Items # 3-5, 7, 8 & F201)					
	8108	Throttle Control and Cable Assembly (Includes Item # 6)	*	*		Service Part Only	
10	8123	Insulation Sleeve (3/8 x 6)	1				
11	8108-8	Throttle Bracket	1				
12	5975-1	Cable Tie (18# x 3-3/4")	1				
13	8108-9	Cable Mount	1				
14	NS	Bolt (Kohler)	1				
15	NS	Wire Clamp	1				

# THROTTLE CONTROL ASSEMBLY

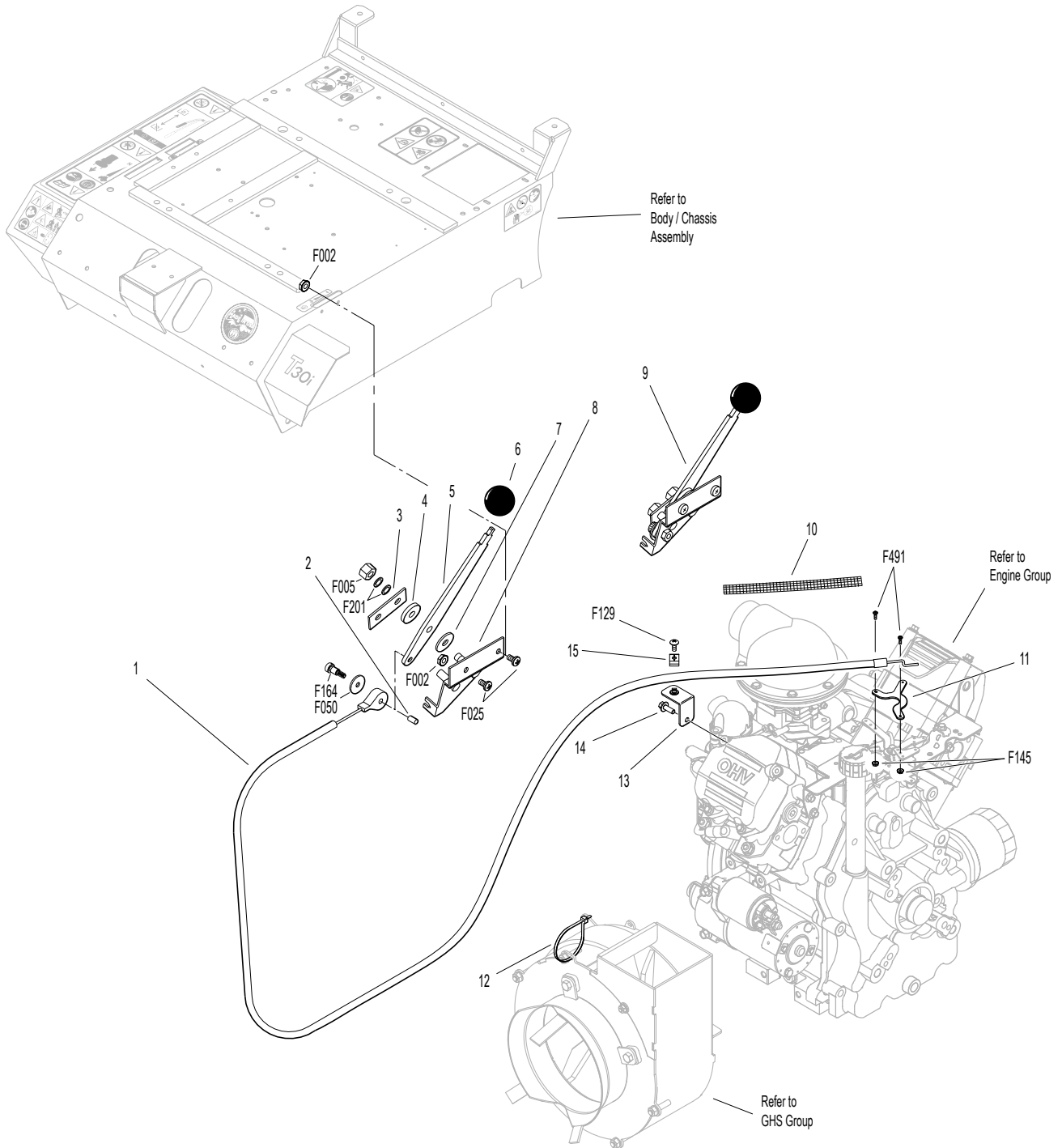

Beginning S/N 124884  
Effective Date 10-07-13  
Use only genuine **Walker**® replacement parts.

# PARKING BRAKE ASSEMBLY

ITEM NO.	PART NO.	DESCRIPTION	NO. REQ'D	ITEM NO.	PART NO.	DESCRIPTION	NO. REQ'D
<b>Parking Brake Assembly</b>				<b>Fasteners</b>			
1	7406-1	Handle Grip, Red	1	F002		10-24 Keps Nut	2
2	7406-8	Parking Brake Lever (4-1/4)	1	F003		1/4-28 Hex Nut	1
3	7406-2	Lever Mount	1	F004		1/4-20 Keps Nut	4
4	5830	Grease Fitting	1	F025		10-24 x 3/8 PPHMS	2
5	7407	Clevis Pin (3/16 x 1/2)	2	F029		1/4-20 x 1/2 Hex Bolt	3
6	7404-6	Brake Actuator Arm	2	F032		1/4-20 x 3/4 Hex Bolt	1
7	7405	Pin, Transmission Lock	2	F054		AN960616 Washer	2
8	7402	Clevis	2	F072		1/4 "E" Retainer Ring	2
9	7408	Compression Spring (1/2 x 3/4)	2	F086		#10 SAE Washer	4
10	7415	Rubber Dust Shield (5/8 x 3/8 x 1/32)	2	F109		1/8 x 5/8 Roll Pin	2
11	5567-3	O-Ring Seal (1/4 x 3/8)	4	F111		1/8 x 3/4 Cotter Pin	1
12	7403	Plunger Bushing, Gear Axle	2	F112		5/8 x 1-1/4 x .03 Washer	2
13	7404-7	Brake Actuator Mount	2	F127		1/16 x 1/2 Cotter Pin	4
14	7412	Clevis Pin (3/16 x 5/8)	2	F261		AN960616L Washer	5
15	5833	Cable Clamp (1/4)	2	F287		1/4-28 Keps Nut	1
16	7410	Brake Control Cable, LH (25.5")	1				
17	7409	Brake Control Cable, RH (20.5")	1				
18	7401-3	Cable Mount Bracket	1				
19	7401-1	Cable Pull Rod	1				
20	5552	Ball Joint (1/4-28)	1				



# PARKING BRAKE ASSEMBLY

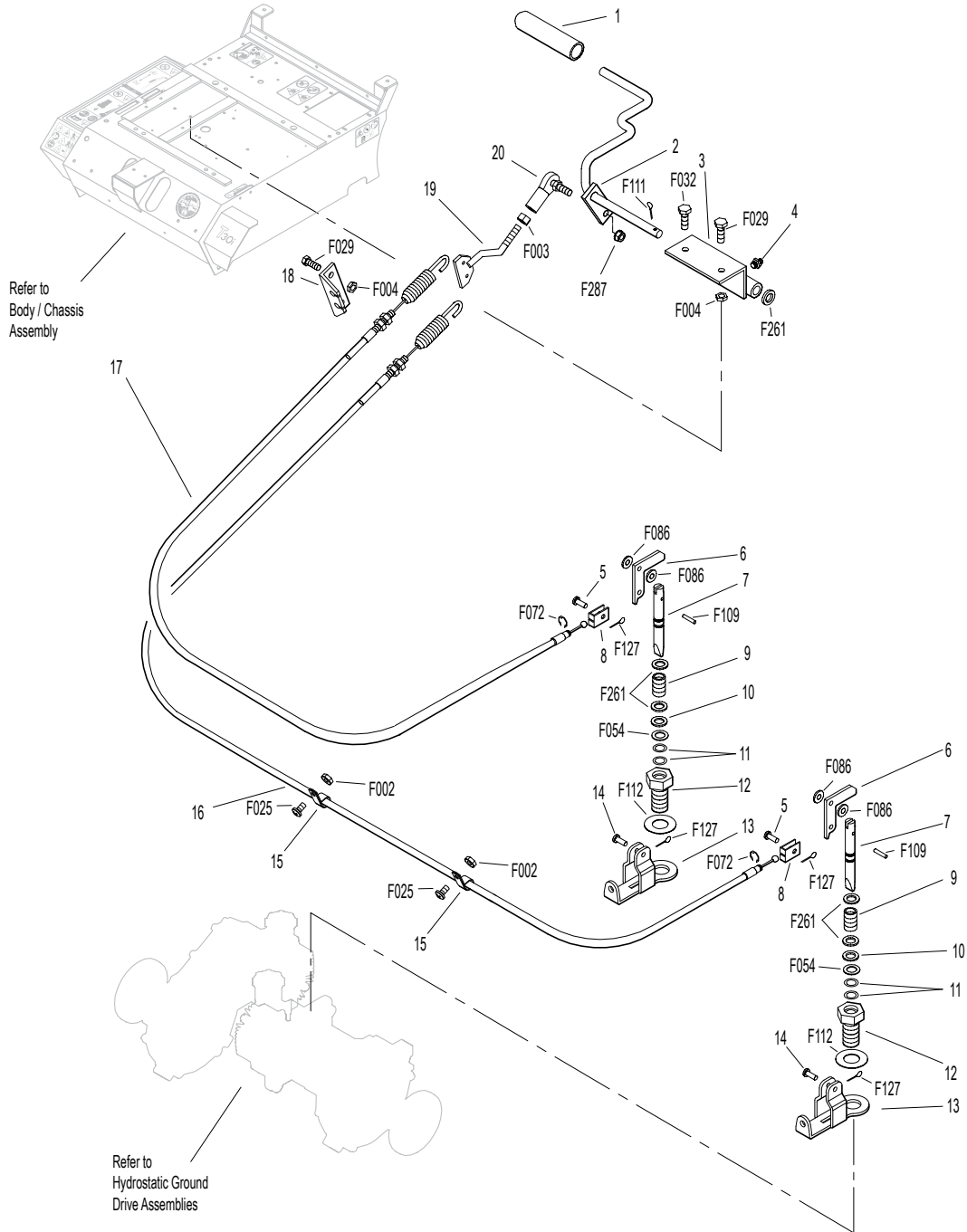

Beginning S/N 124884  
 Effective Date 10-07-13  
 Use only genuine **Walker**® replacement parts.

# GHS GROUP

ITEM NO.	PART NO.	DESCRIPTION	NO. REQ'D	ITEM NO.	PART NO.	DESCRIPTION	NO. REQ'D
<b>Delivery Chute Assembly</b>				<b>Fasteners</b>			
1	5515-2	Elbow Delivery Spout	1	F002	10-24 Keps Nut		6
2	5592-13	Backing Plate, Grass-Pak® Switch	1	F004	1/4-20 Keps Nut		3
3	5578	Rear Clip, Chute Mount	1	F009	5/16-18 Whiz Locknut		7
4	5577	Side Clip, Chute Mount	2	F012	3/8-16 Keps Nut		3
5	8511-1	Delivery Chute W/Clips / 10.0 (Includes Items # 3, 4, 6, F362 & F411)	1	F026	10-24 x 1/2 PPHMS		2
6	5578-10	Front Clip, Chute Mount	1	F029	1/4-20 x 1/2 Hex Bolt		3
7	7530-4	Body Chute (10.5 Blower)	1	F034	5/16-18 x 3/4 Hex Bolt		1
<b>Blower Belt Tightener Assembly</b>				F039	3/8-16 x 1-1/4 Hex Bolt		1
8	7238-6	Blower Drive Pulley (Includes Items # F075, F114 & F231)	1	F040	3/8-16 x 1-1/2 Hex Bolt		1
9	7234-2	Blower Belt (Micro-V)	1	F042	3/8-16 x 2-1/4 Hex Bolt		1
10	7239-1	Blower Pulley (Mirco-V) (Includes Items # F067, F075 & F114)	1	F050	1/4 SAE Washer		1
11	7364-2	Torsion Spring	1	F054	AN960616 Washer		1
12	7201-3	Fiberglide Bearing	2	F067	3/16 x 3/16 x 1 Key		1
13	5830-3	Grease Fitting (45 Deg.)	1	F075	5/16-18 x 1/2 SQH Set Screw		2
14	7364-1	Blower Belt Tightener Arm	1	F079	A/A66D Aluminum Pop Rivet		6
15	7201-4	Inner Race (1-1/2)	1	F114	5/16-18 x 5/8 SQH Set Screw		2
16	5841	Retainer Washer (3/8 x 1-1/4)	1	F128	10-24 x 3/8 PTHMS		4
17	5245	Idler Pulley (3")	1	F131	5/16-18 x 1/2 Hex Bolt		3
<b>Blower Assembly</b>				F132	1/4-20 x 2-3/4 Hex Bolt		2
18	7544	Blower Assembly (10.5") (Includes Items # 19-24, F004, F009, F029, F050, F131, F168 & F426)	1	F168	5/16 Split Lock Washer		3
19	5268	Bearing W/Collar (3/4)	2	F217	7/16-14 Hex Nut		1
20	7544-3	Blower Housing (10.5)	1	F218	7/16 Split Lock Washer		1
21	7545-2	Blower Output Shaft (10.5)	1	F231	1/4 x 3/4 Woodruff Key (# 806)		1
22	7545	Blower Wheel (10.5")	1	F281	7/16-14 x 1-3/4 Hex Bolt		1
23	7543-1	Blower Faceplate (10.5)	1	F362	A/A62D Alum. Pop Rivet (3/16D x 13/32L)		2
24	7526	Intake Tube (10.5 Blower)	1	F411	3/16 Bulbex Rivet		6
25	5595-2	Intake Cover / GHS	1	F426	1/4-20 x 1/2 Carriage Bolt		1
26	7528-4	Skid Bar (10.5" Blower)	1				

# GHS GROUP

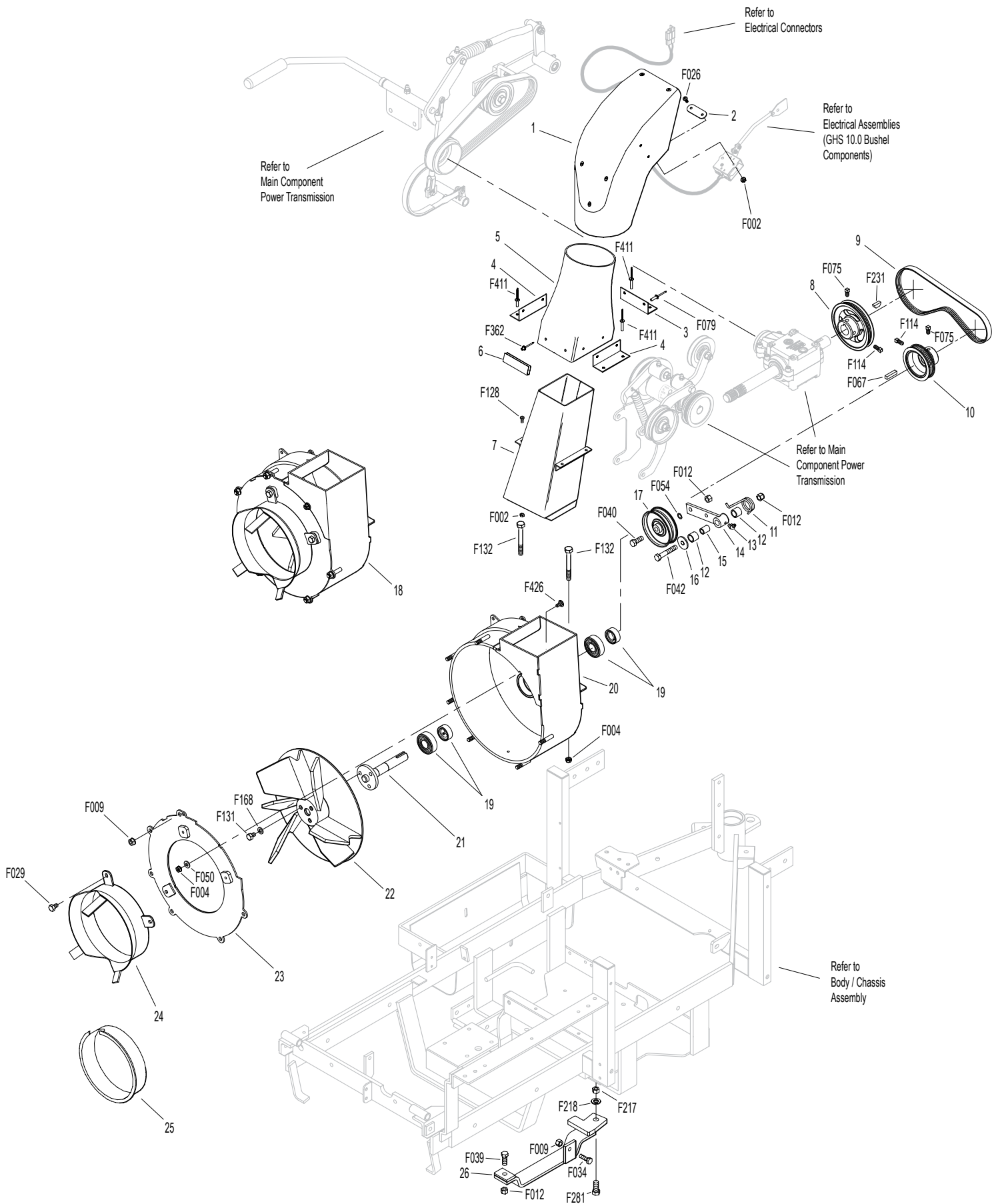

Beginning S/N 124884  
 Effective Date 10-07-13  
 Use only genuine **Walker**® replacement parts.

# GHS POWERFIL® ASSEMBLY (10.0)

ITEM NO.	PART NO.	DESCRIPTION	NO. REQ'D	ITEM NO.	PART NO.	DESCRIPTION	NO. REQ'D
<b>10.0 GHS Powerfil® Assembly</b>				<b>Fasteners</b>			
1	5551-3	Bearing Cap, Powerfil®	1	F002		10-24 Keps Nut	10
2	5551-1	Pivot Bearing (#S3PP)	2	F003		1/4-28 Hex Nut	3
3	5518-2	Pivot, Delivery Spout	1	F026		10-24 x 1/2 PPHMS	1
4	5517-2	Pivot Mount	1	F037		10-24 x 5/8 PTH Screw	2
5	5552	Ball Joint (1/4-28)	2	F054		AN960616 Washer	1
6	5558-1	Powerfil® Push Rod	1	F085		3/16 Rivet Backup Washer	1
7	5553-3	Bushing, Powerfil® Actuator	4	F101		10-24 x 1-1/4 SHC Screw	1
8	5553-1	Compression Spring (1/2 x 2)	2	F109		1/8 x 5/8 Roll Pin	1
9	5558-2	Powerfil® Actuator Rod	1	F129		10-24 x 1/2 PTHMS	6
	5549	Actuator Rod Assembly (Includes Items # 5-9 & F003)	*	F261		AN960616L Washer	1
10	5554	Actuator Arm	1	F287		1/4-28 Keps Nut	1
11	5519-3	Motor Mount Nut (5/8-24)	*	* Service Part Only			
12	5519-2	Motor Mount Washer	*				
13	5976-2	Grommet (3/16 x 3/4)	1				
14	5519-5	Actuator Motor (12V) (Includes Items # 11 & 12)	1				

# GHS POWERFIL® ASSEMBLY (10.0)

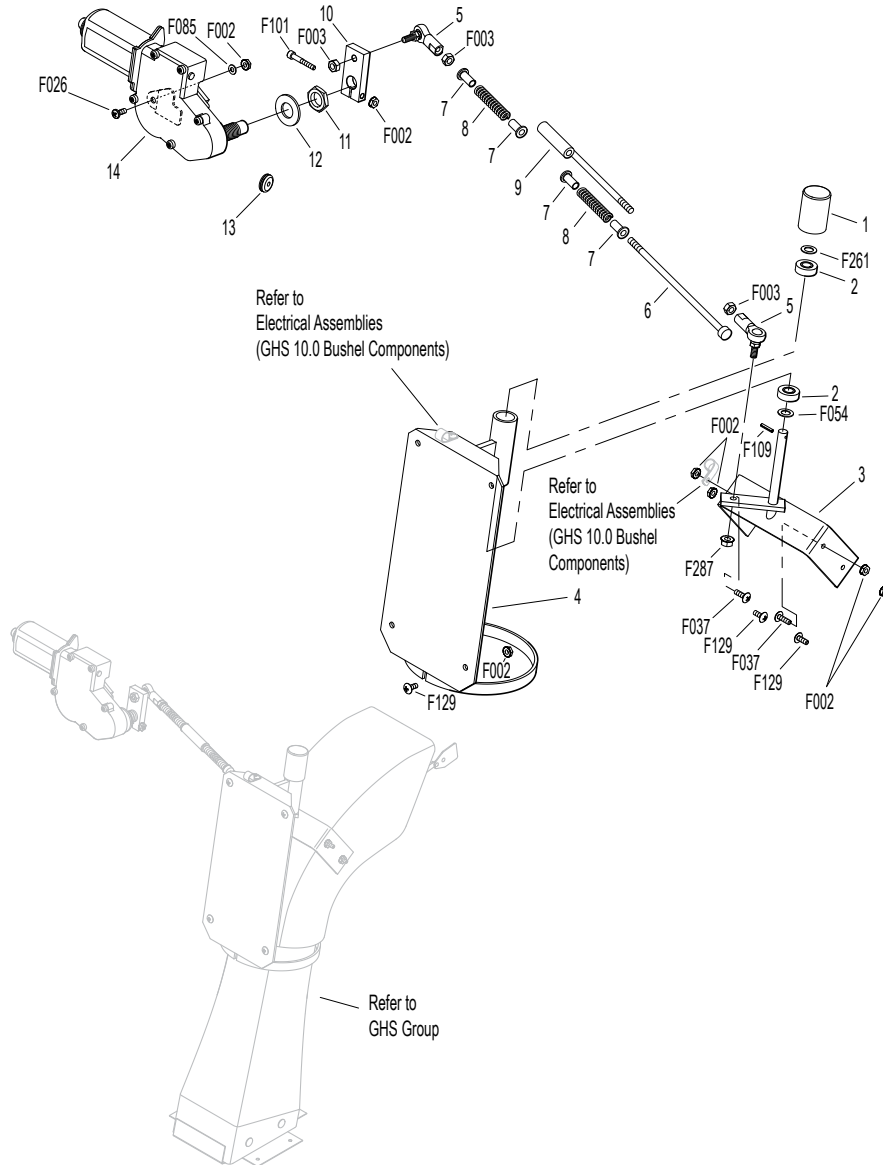

# GHS 10.0 BUSHEL CATCHER ASSEMBLY

ITEM NO.	PART NO.	DESCRIPTION	NO. REQ'D	ITEM NO.	PART NO.	DESCRIPTION	NO. REQ'D
<b>Upper Baffle Screen Assembly (Removable)</b>				45	8608-10	Box Support, Gas Spring	2
1	7512-2	Removable Screen (3/16 Hole) (Includes Items # 2, 5, F025 & F190)	1**	46	7532-1	Handle, Catcher Lift	2
2	7506	Knob / Threaded Insert (10-24)	2	47	5977	Grommet (1/2 x 7/8 x 1/16)	2
3	8606-3	Channel Top, LH	1	48	8117	Wire Harness Channel	1
4	8606-2	Channel Bottom	2	49	8602-3	10.0 Catcher W/O Powerfil®, Gray (Includes Door)	*
5	7856-1	Edge Molding (26")	1		8602-4	10.0 Catcher W/Powerfil®, Gray (Includes Door)	*
6	7507	Screen Seal (27-1/2)	1		8610-5	10.0 Bushel Catcher Box, Gray	*
7	7505	Mustache Spring	2	50	8607-9	Powerfil® Cover Plate	1
8	8606	C-Channel (10.0)	1	51	8155-2	Gas Spring Cover, RH	1
	8606-20	C-Channel With Spring (10.0) (Includes Items # 7, 8 & F340)	*	52	8608-8	Hinge Plate, RH	1
9	8606-4	Channel Top, RH	1	53	8608-9	Torsion Bar	1
<b>10.0 Exhaust Deflector Door Assembly</b>				<b>5598-2 Optional Dump Bag (Not Shown)</b>			
10	8607-6	Upper Seal Support	1	May be ordered as an option. Contact your Walker dealer.			
11	8607-5	Upper Door Seal	1	<b>Fasteners</b>			
12	8607-11	Backup Plate	1	F002	10-24 Keps Nut		28
13	8512-3	10.0 Catcher Box Door (Includes Items # 10-14, 16, 17, F085, F330 & F411)	1	F004	1/4-20 Keps Nut		25
14	5583	Handle	1	F009	5/16-18 Whiz Locknut		4
15	8607-1	Door Mount, LH	1	F020	5/16-18 ESNA Nut		2
16	8607-12	Upper Door Stiffener	1	F024	5/16-24 Jam Nut		4
17	8607-7	Lower Door Stiffener	1	F025	10-24 x 3/8 PPHMS		4
18	8607-8	Door Guide	1	F026	10-24 x 1/2 PPHMS		2
19	8607-2	Door Mount, RH	1	F027	10-24 x 5/8 PPHMS		6
<b>GHS 10.0 Bushel Catcher Assembly</b>				F029	1/4-20 x 1/2 Hex Bolt		10
20	8608-5	Center Strap	1	F049	5/16 SAE Washer		8
21	8608-3	Upper Frame Doubler	2	F050	1/4 SAE Washer		2
22	8608-1	Outside Box Strap, LH	2	F068	1/8 x 1 Cotter Pin		2
23	8608-2	Lower Frame Doubler	2	F079	A/A66D Aluminum Pop Rivet		14
24	8608-4	Center Frame Doubler	1	F085	3/16 Rivet Backup Washer		13
25	8608-11	Catcher Door Finger	1	F094	8-32 x 1/2 PTHMS		6
26	8608-6	Catcher Mount	1	F129	10-24 x 1/2 PTHMS		18
27	8610-4	Catcher Dump Flap W/Plate 10.0	1	F190	#10 Internal Star Lock Washer		2
28	8610-3	Backing Plate, Dump Flap	1	F195	1/4-20 x 3/4 PPHMS, SS		4
29	7584	Reinforcing Strap	1	F196	1/4-20 x 1 PPHMS, SS		4
30	5103-5	Pivot Bushing Inner	2	F208	5/16-18 x 2-1/4 Hex Bolt		2
31	5801-3	Decal Plate, Round (Set of 2)	1	F230	1/4-20 x 1-1/4 PPHMS, SS		4
32	7620-3	Pivot Bushing (1/2 x 9/16)	2	F242	1/4-20 x 7/8 PPHMS, SS		8
33	8608-7	Hinge Plate, LH	1	F330	3/16D x 21/32L Rivet, SS		9
34	5103-7	Outside Torsion Bushing	2	F340	Rivet, Aluminum		4
35	8607-4	Upper Arm	2	F351	Aluminum Pop Rivet		6
36	5214-12	Ball Joint (5/16-24)	4	F360	1/4-20 x 3/8 Hex Bolt		2
37	5155-12	5/16 Ball Stud	2	F390	1/4-20 x 7/8 Carriage Bolt		4
38	5155-4	Gas Spring	2	F411	3/16 Bulbex Rivet		10
39	5147	Spring Clip	4	F456	5/16-18 x 3/4 SBH Cap Screw, SS		4
40	8155-1	Gas Spring Cover, LH	1	F503	1/4-20 x 1-1/2 PPHMS, SS		1
41	8607-3	Lower Arm	2	F524	3/16 x 3/8 Aluminum Rivet, Black		6
42	5103-6	Pivot Bushing Outer	2	* Service Part Only			
43	5155-13	3/4 Ball Stud	2	** This screen can be replaced by P/N 7512-3 Removable Screen (3/4" holes) for improved air flow performance in wet conditions.			
44	5523-6	Gas Spring Plate	2				

Beginning S/N 124884

Effective Date 10-07-13

Use only genuine Walker® replacement parts.

# GHS 10.0 BUSHEL CATCHER ASSEMBLY

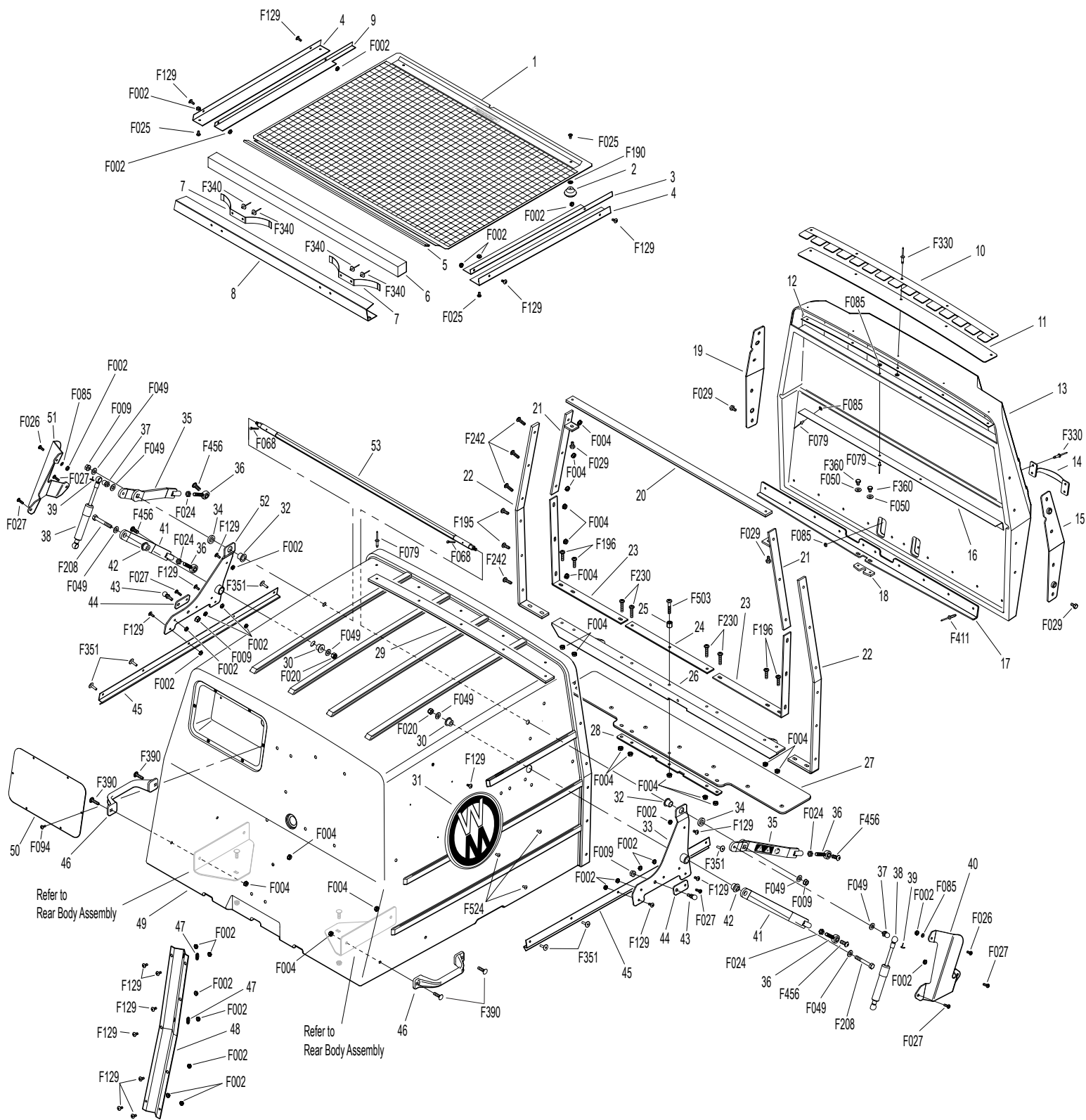

Beginning S/N 124884  
 Effective Date 10-07-13  
 Use only genuine **Walker**® replacement parts.

# INSTRUMENT PANEL ASSEMBLY

ITEM NO.	PART NO.	DESCRIPTION	NO. REQ'D	ITEM NO.	PART NO.	DESCRIPTION	NO. REQ'D
<b>Instrument Panel Assembly</b>				21	8385	Panel Box W/Graphic	1
1	7307-2	Instrument Panel Cover (Optional)	**	22	7977-1	Grommet (1/8 x 1-1/16)	1
	8306-7	Instrument Panel Assembly (Includes Items # 2-15, 24, 25, F129, F228, F250, F251 & F349)	1	23	7307-16	Lining, Panel Box (1/8)	1
2	7307-7	Panel Frame	1	24	8536	Warning Horn	1
3	8820-6	Panel Faceplate W/Decal	1	25	6942	Relay Switch (30/40 Amp) NC (Includes Items # 26 & 27)	3
4	7386	Panel Gasket	1	26	6941-6	Relay Switch (30/40 Amp)	*
5	8960-15	Ignition Switch (with Keys) (Includes Items # 17, 18 & F349)	1	27	6941-7	Relay Mount	*
6	8996-15	Red Indicator Light Assembly	3	<b>Fasteners</b>			
7	7941-3	Boot, Circuit Breaker	2		F002	10-24 Keps Nut	3
8	7941-5	Circuit Breaker (7 Amp)	1		F004	1/4-20 Keps Nut	6
9	7941-2	Circuit Breaker (10 Amp)	1		F129	10-24 x 1/2 PTHMS	1
10	8990-1	Hourmeter (Global)	1		F228	#6 x 5/8 PPHSMS, SS	8
11	5995	Toggle Switch (Off-On)	1		F238	J Clip, Instrument Panel	8
12	5995-2	Switch Boot	1		F250	6-32 x 1/2 PPHMS	2
13	7306-14	Water Temperature Gauge	1		F251	6-32 Keps Nut	2
14	8997	Voltmeter Gauge	1		F349	Washer .835 ID, 1.122 OD, SS	1
15	8945-5	Wire Harness, Instrument Panel	1	* Service Part Only			
16	5975-1	Cable Tie (18# x 3-3/4")	2	** May be ordered as an option. Contact your Walker dealer.			
17	8960-3	Key Set W/Umbrella	*	<b>NOTE:</b> Refer to <b>ELECTRICAL CONNECTORS</b> , Page 38 for identification of all Electrical Wiring Service Parts.			
18	7854	Plastic Tip, Red	1				
19	7307-1	Shock Mount (1.0 x .25)	3				
20	7391	Panel Box Mount Plate	2				



# INSTRUMENT PANEL ASSEMBLY

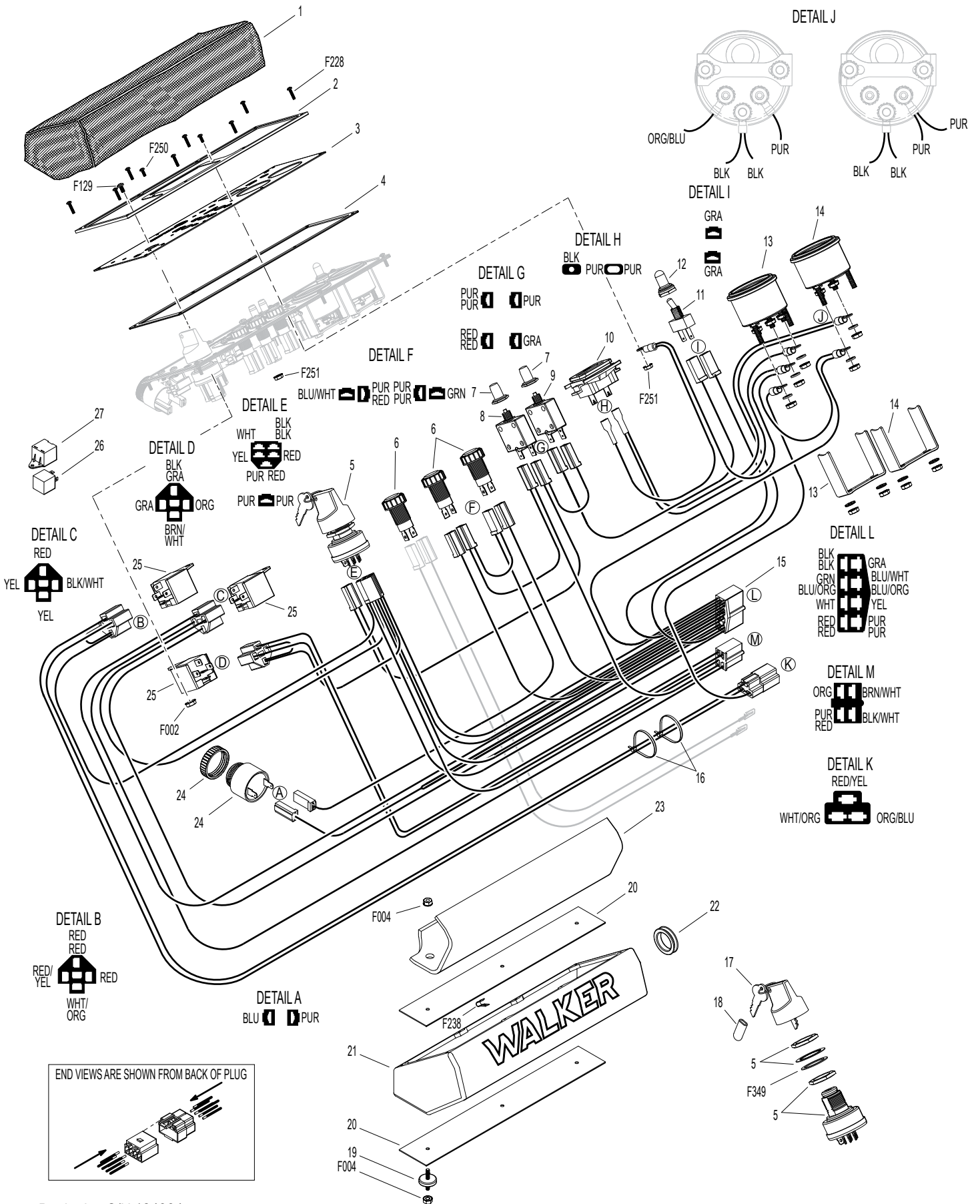

Beginning S/N 124884  
 Effective Date 10-07-13  
 Use only genuine **Walker**® replacement parts.

# ELECTRICAL ASSEMBLY

ITEM NO.	PART NO.	DESCRIPTION	NO. REQ'D	ITEM NO.	PART NO.	DESCRIPTION	NO. REQ'D
<b>Harness Assembly</b>				<b>Fasteners</b>			
1	5975-3	Cable Tie (50# x 7")	6	F002		10-24 Keps Nut	8
2	5942-4	Safety Switch (NO)	1	F004		1/4-20 Keps Nut	4
3	5833	Cable Clamp (1/4)	1	F009		5/16-18 Whiz Locknut	1
4	8940-9	Wire Harness	1	F019		1/4-20 ESNA Wing Nut	2
5	5832	Cable Clamp (1/2)	5	F025		10-24 x 3/8 PPHMS	3
6	8950	Wire Harness (9.5 / 10.0)	1	F026		10-24 x 1/2 PPHMS	3
7	7833-2	Cable Clamp (1 x 1/4)	2	F031		1/4-20 x 5/8 Hex Bolt	2
8	6942	Relay Switch (30/40 Amp) NC (Includes Items # 16 & 17)	1	F032		1/4-20 x 3/4 Hex Bolt	2
9	7948-6	Time Delay Module	1	F050		1/4 SAE Washer	4
10	7948-5	Time Delay Harness	1	F061		1/4 Star Lock Washer	1
11	8941	Circuit Breaker (30 Amp) Auto Reset / Sealed	1	F079		A/A66D Aluminum Pop Rivet	4
12	8943	Positive Battery Lead Wire (Red)	1	F085		3/16 Rivet Backup Washer	1
13	5942-5	Safety Switch (Normal Open)	1	F093		5/16-18 x 1 Hex Bolt	1
14	5975-1	Cable Tie (18# x 3-3/4")	3	F124		10-32 x 3/8 Tapitite Machine Screw	2
15	6103-19	Adapter Harness	1	F129		10-24 x 1/2 PTHMS	1
16	6941-7	Relay Mount	*	F232		10-32 Keps Nut	2
17	6941-6	Relay Switch (30/40 Amp)	*	F284		M6 x 1.0 x 8 SCH Screw	1
<b>Battery Assembly</b>				* Service Part Only			
18	6923	Negative Battery Cable	1	<b>NOTE:</b> Refer to <b>ELECTRICAL CONNECTORS</b> , Page 38 for identification of all Electrical Wiring Service Parts.			
19	5933	Battery Terminal Insul., Red (+)	1				
20	5844-3	Battery Hold-Down Bar	1				
21	5839	Hook Bolt	2				
22	7390-1	Battery Pan	1				
23	NS	Battery (12V/340CCA/Wet)	1				
24	5932	Battery Terminal Insul., Black (-)	1				
25	7834-2	Wire Saddle (2 Wires)	1				

# ELECTRICAL ASSEMBLY

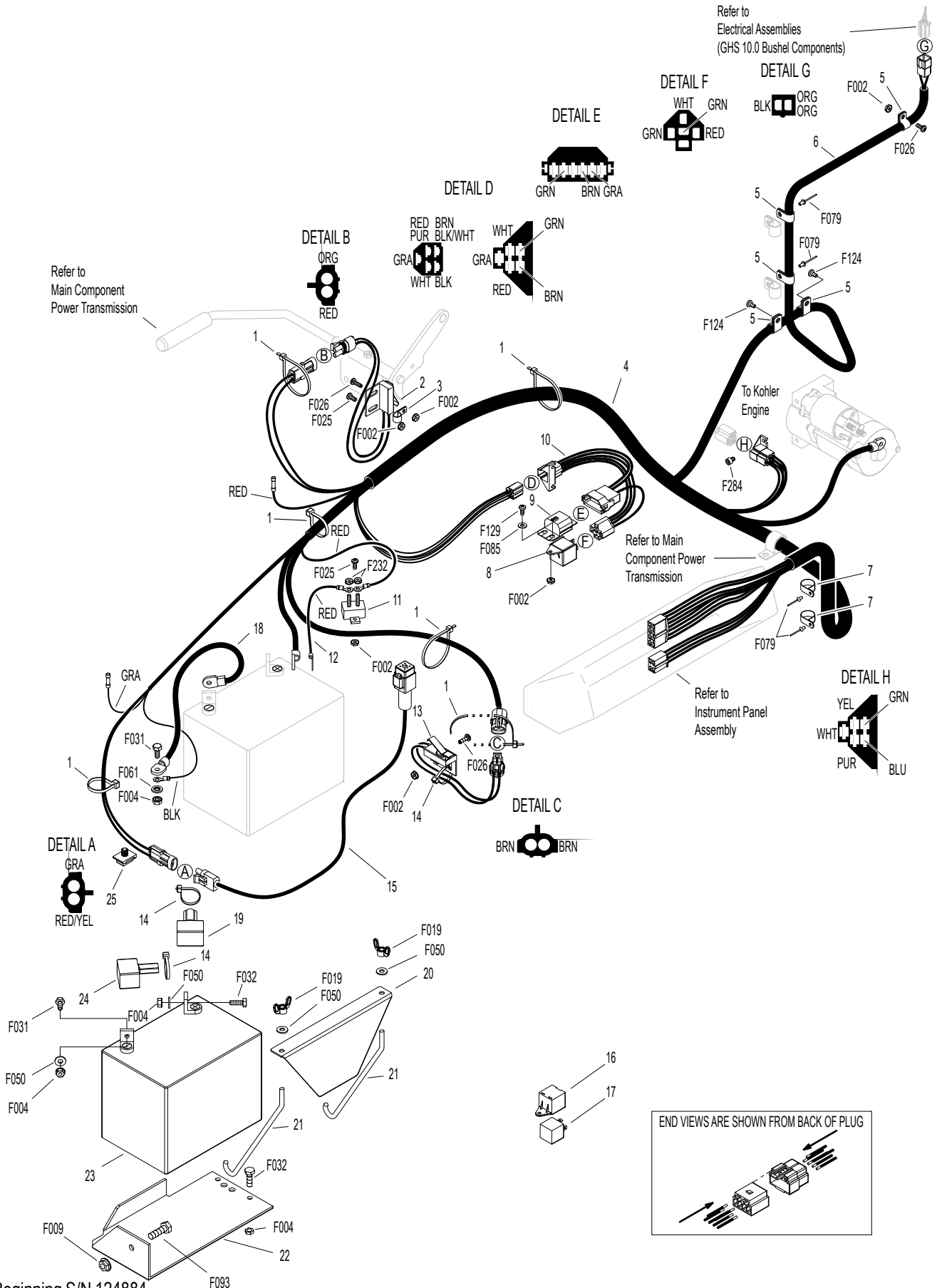

Beginning S/N 124884  
 Effective Date 10-07-13  
 Use only genuine **Walker**® replacement parts.





# ELECTRICAL ASSEMBLIES (GHS 10.0 BUSHEL COMPONENTS)

ITEM NO.	PART NO.	DESCRIPTION	NO. REQ'D	ITEM NO.	PART NO.	DESCRIPTION	NO. REQ'D
<b>10.0 Harness Components</b>				<b>Fasteners</b>			
1	5519-4	Adapter Harness	1	F002		10-24 Keps Nut	4
2	5975-1	Cable Tie (18# x 3-3/4")	1	F025		10-24 x 3/8 PPHMS	1
3	7835	Frame Clip (3/16)	6	F037		10-24 x 5/8 PTH Screw	1
4	5975-3	Cable Tie (50# x 7")	1	F129		10-24 x 1/2 PTHMS	2
5	5536-2	Horn, Full Signal	*	F508		4-40 Keps Nut, SS	2
6	8950	9.5 / 10.0 Wire Harness	1	F509		4-40 x 1/2 Hex Head, SS	2
7	5977-2	Grommet, Cut (1/8 x 3/8)	1				
<b>Grass-Pak® Switch Assemblies</b>				* Service Part Only			
8	5594-6	Aluminum Shaft & Vane Assembly	1	<b>NOTE:</b> Refer to <b>ELECTRICAL CONNECTORS</b> , Page 38 for identification of all Electrical Wiring Service Parts.			
9	5592-14	Grass-Pak® Switch Assembly	1				
10	5833	Cable Clamp (1/4)	2				

# ELECTRICAL ASSEMBLIES (GHS 10.0 BUSHEL COMPONENTS)

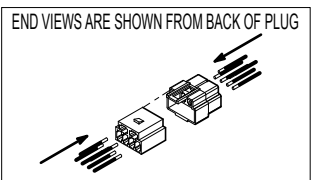
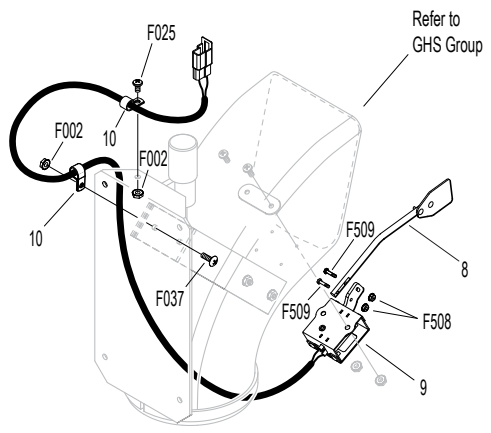
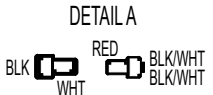
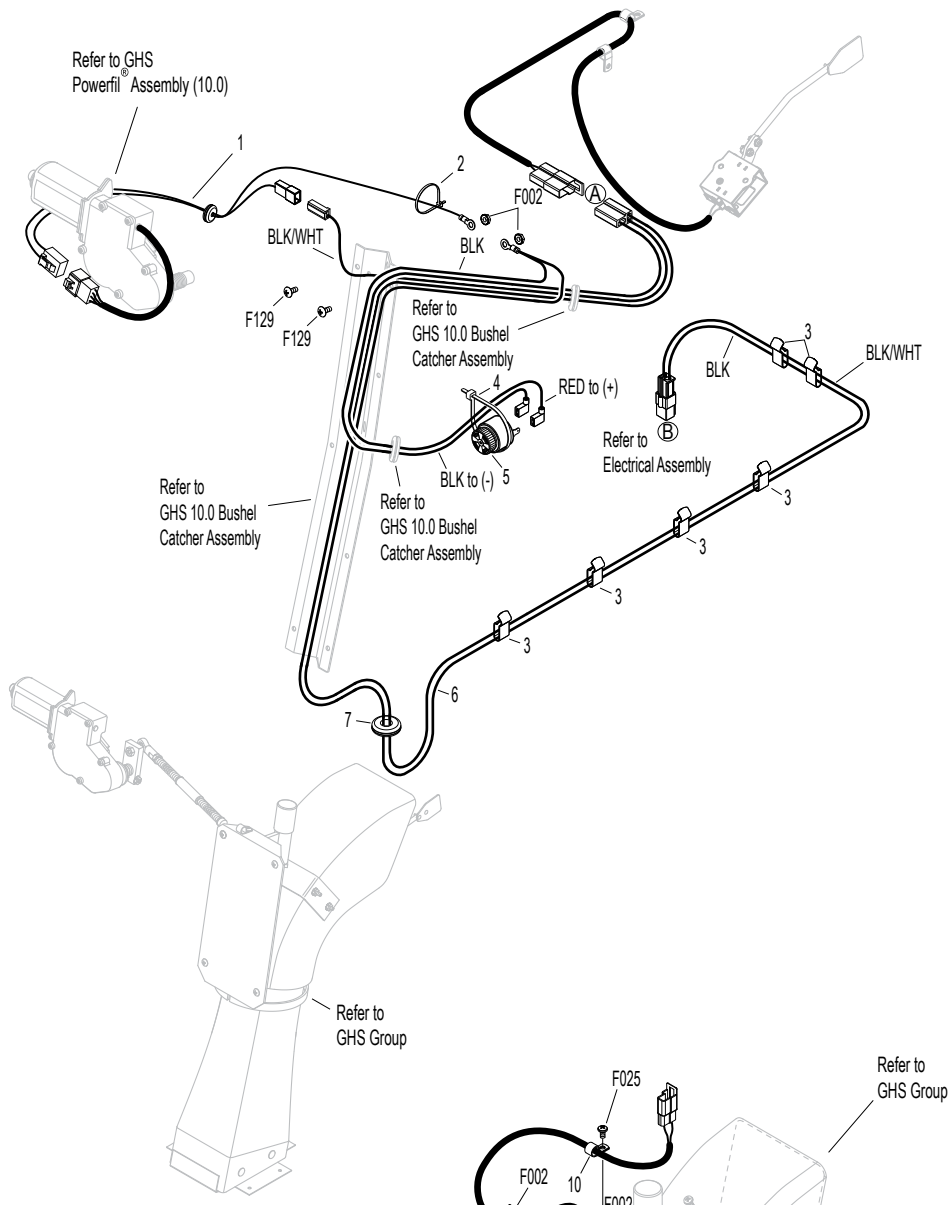

Beginning S/N 124884  
 Effective Date 10-07-13  
 Use only genuine **Walker**® replacement parts.

# ELECTRICAL CONNECTORS

ITEM NO.	PART NO.	DESCRIPTION	NO. REQ'D	ITEM NO.	PART NO.	DESCRIPTION	NO. REQ'D
<b>Electrical Wiring Service Parts</b>				29	7942-1	2-Way Locking Connector, Female	*
1	5996-1	16-14 GA Butt Connector	*	30	7942-2	2-Way Connector, Male	*
2	5996-11	12-10 GA Butt Connector	*	31	7942-3	2-Way Connector, Female	*
3	7942-14	16-14 GA Shrink Connector	*	32	7942-10	2-Way Locking Connector, Male	*
4	7942-13	12-10 GA Shrink Connector	*	33	5940-8	3-Way Connector, Male	*
5	5995-1	Wire Terminal Adapter	*	34	7942-9	3-Way Connector, Male	*
6	5996-4	16-14 GA Bullet Conn., Male	*	35	8944	3-Way Locking Connector, Male	*
7	5996-5	16-14 GA Bullet Conn., Female	*	36	8944-1	3-Way Locking Connector, Female	*
8	5940-4	16-14 GA Spg. Loaded Term., Female	*	37	7942-11	4-Way Connector, Male	*
9	5940-7	Wire Clip, Female	*	38	7942-12	4-Way Connector, Female	*
10	5996	1/4 x 16-14 GA QKS Term., Female	*	39	7942-5	5-Way Connector, Male	*
11	5996-2	3/16 x 22-18 GA QKS Term., Female	*	40	5940-2	5-Way Connector, Male	*
12	7996	16-14 GA QKS Term., Female	*	41	8942-1	5-Way Connector, Female	*
13	5940-5	16-14 GA Spg. Loaded Term., Male	*	42	7942-6	6-Way Connector, Male	*
14	5996-0	1/4 x 22-18 GA QKS Term., Male	*	43	7942-7	6-Way Connector, Male	*
15	5996-18	16-14 GA Ring Term. (#8) Nylon Insulated	*	44	7942-8	8-Way Connector, Male	*
16	7996-1	1/4 x 16-14 GA QKS Term., Male	*	45	8942-2	8-Way Connector, Female	*
17	5996-8	6 GA Ring Lug (5/16)	*	46	8942-3	5-Way Connector, Male	*
18	5996-9	22-18 GA Ring Term., #10	*	47	5940-9	3-Way Connector (M)	*
19	5996-10	16-14 GA Ring Term. (5/16)	*	48	7942-15	6-Way Connector (Female)	*
20	5996-12	12-10 GA Ring Term. (5/16)	*	49	7940-3	Packard Plug (Male)	*
21	5996-13	16-14 GA Ring Term., # 10	*	50	7940-4	Packard Plug (Female)	*
22	5996-15	12-10 GA Ring Term. (1/2)	*	* Service Part Only			
23	5996-16	6 GA Ring Terminal (1/4)	*	<b>NOTE:</b> Not all Electrical Connectors are used with all assemblies.			
24	5996-17	16-14 GA Ring Term. (1/4)	*	<b>NOTE:</b> Refer to <b>ELECTRICAL ASSEMBLY</b> , Page 32 for locations of Wiring Harness and of all Electrical Wiring Service Parts.			
25	5996-20	12-10 GA Ring Term. (1/4)	*				
26	5996-21	12-10 GA Ring Term., #10	*				
27	7942-4	Single Connector, Male	*				
28	8942	2-Way Connector, Male	*				



# ELECTRICAL CONNECTORS

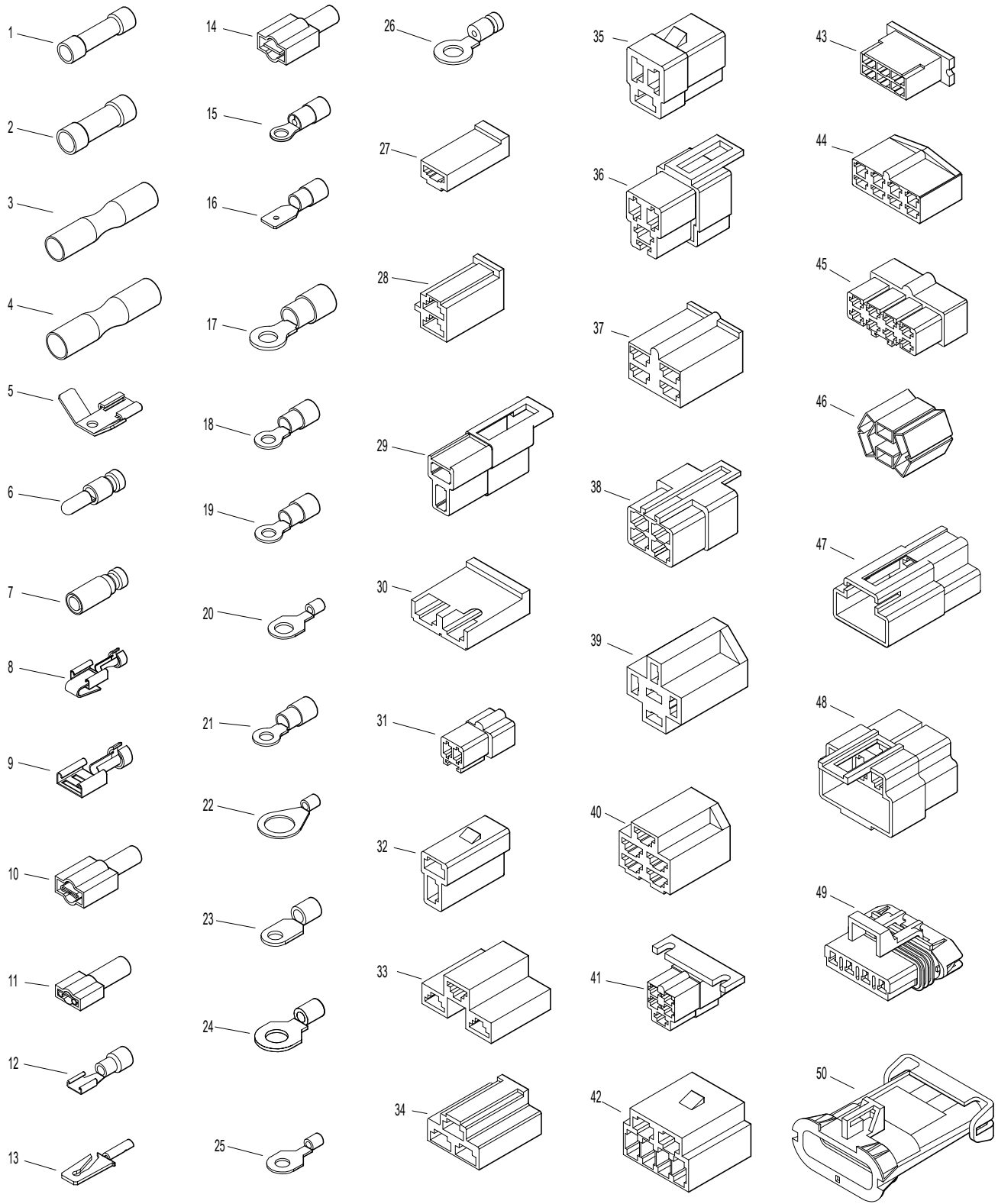

Beginning S/N 124884  
Effective Date 10-07-13  
Use only genuine Walker® replacement parts.

# LUBRICATION POINTS

ITEM NO.	LOCATION	LUBRICATION TYPE	NO. PLACES	ITEM NO.	LOCATION	LUBRICATION TYPE	NO. PLACES
<b>Lubrication Points</b>				17	Brake Actuator Rod and Brake Band Pivot Pins (Clevis)	Oil	3
1	Steering Lever Pivot	Grease	4	18	Brake Actuator Pivot	Grease	1
2	Body Hinge Point	Oil	2	19	Throttle Control Cable Ends	Oil	2
3	Deck-to-PTO Coupling (Grease Spline Slide Area)	Grease	1	20	Catcher Hinge Point	Oil	2
4	FSC Actuator Rod Pivot Pins	Oil	2	21	Rear Wheel Bearings	Grease	2
5	(FSC) Friction Body Pivot	Grease	1	22	Engine Oil	Oil**	1
6	FSC Lever Pivot	Grease	1	23	Belt Tightener Pivot, Blower Drive (GHS Model Only)	Grease	1
7	FSC Lever Fork (Grease Slide Area)	Grease	1	24	Belt Tightener Pivot, Ground Drive	Grease	1
8	Deck Support Arm Pivot	Grease	2	25	PTO Gearbox Dipstick	Oil**	1
9	Universal Joint Tube Assembly	Grease*	1	26	Hydrostatic Drive	Oil**	2
10	Parking Brake Lever	Grease	1	27	Throttle Control Pivot	Oil	1
11	Universal Joint Quick Connect Spline (Grease Slide Area)	Grease	1	* Grease every eight (8) hours.			
12	Gear Axle	Oil**	2	** Refer to MT <b>Operator's Manual</b> for procedure for checking and changing oil in Engine Crankcase, Hydrostatic Transmissions and Gear Axles.			
13	Belt Tightener Pivot, Jackshaft Drive	Grease	1	<b>NOTE:</b> See Model MT <b>Operator's Manual</b> for proper lubrication intervals.			
14	PTO Clutch Lever Pivot	Grease	1				
15	Clutch Actuator Push Rod	Grease	2				
16	Belt Tightener Pivot, PTO Clutch	Grease	1				

# LUBRICATION POINTS

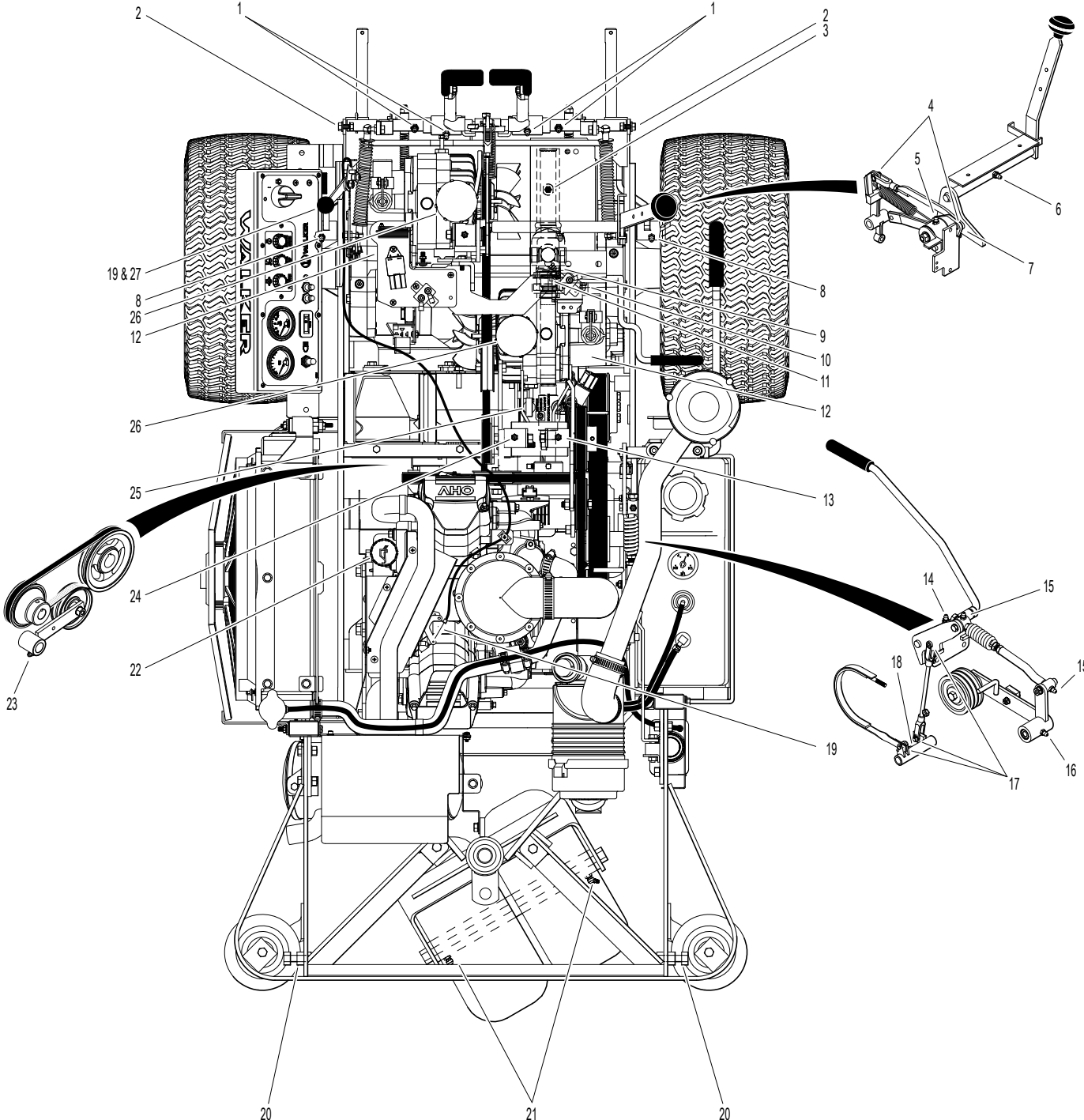

Beginning S/N 124884  
Effective Date 10-07-13  
Use only genuine Walker® replacement parts.

# WIRING SCHEMATIC

## WALKER MODEL T30i Beginning S/N 124884

- S1 = START CIRCUIT
- S2 = START / ACCESSORY CIRCUIT
- M = MAGNETO GROUND CIRCUIT
- B = BATTERY CIRCUIT
- A = ACCESSORY CIRCUIT
- G = GROUND CIRCUIT
- J1 = #1 FUEL INJECTOR
- J2 = #2 FUEL INJECTOR
- J3 = THROTTLE POSITION SENSOR
- J4 = OIL TEMP SENSOR
- J5 = OXYGEN SENSOR
- J6 = REGULATOR / RECTIFIER
- J8 = ENGINE GROUND
- J10 = #1 IGNITION COIL
- J11 = #2 IGNITION COIL
- J12 = #1 IGNITION COIL
- J13 = #2 IGNITION COIL
- J14 = IGNITION COIL GROUND
- J20 = SPEED PICK-UP SENSOR

RELAY - A	
PTO RELAY	
OFF	30 + 87A
START	30 + 87A
PTO ON	OPEN

RELAY - B	
START RELAY	
OFF	OPEN
START	30 + 87
RUN	OPEN

RELAY - C	
FAN INTERRUPT RELAY	
OFF	30 + 87A
START	OPEN
PTO ON	30 + 87A

RELAY - D	
FAN SPEED CONTROL	
OFF	30 + 87A
START	30 + 87A
PTO ON	30 + 87

RELAY - E	
DELAY RELAY	
OFF	30 + 87A
START	OPEN
PTO ON	OPEN

RELAY - F	
IGNITION / FUEL RELAY	
OFF	OPEN
START	OPEN
PTO ON	30 + 87

IGNITION SWITCH CIRCUITS	
OFF	G + M
START	B + A / S1 + S2
RUN	B + A

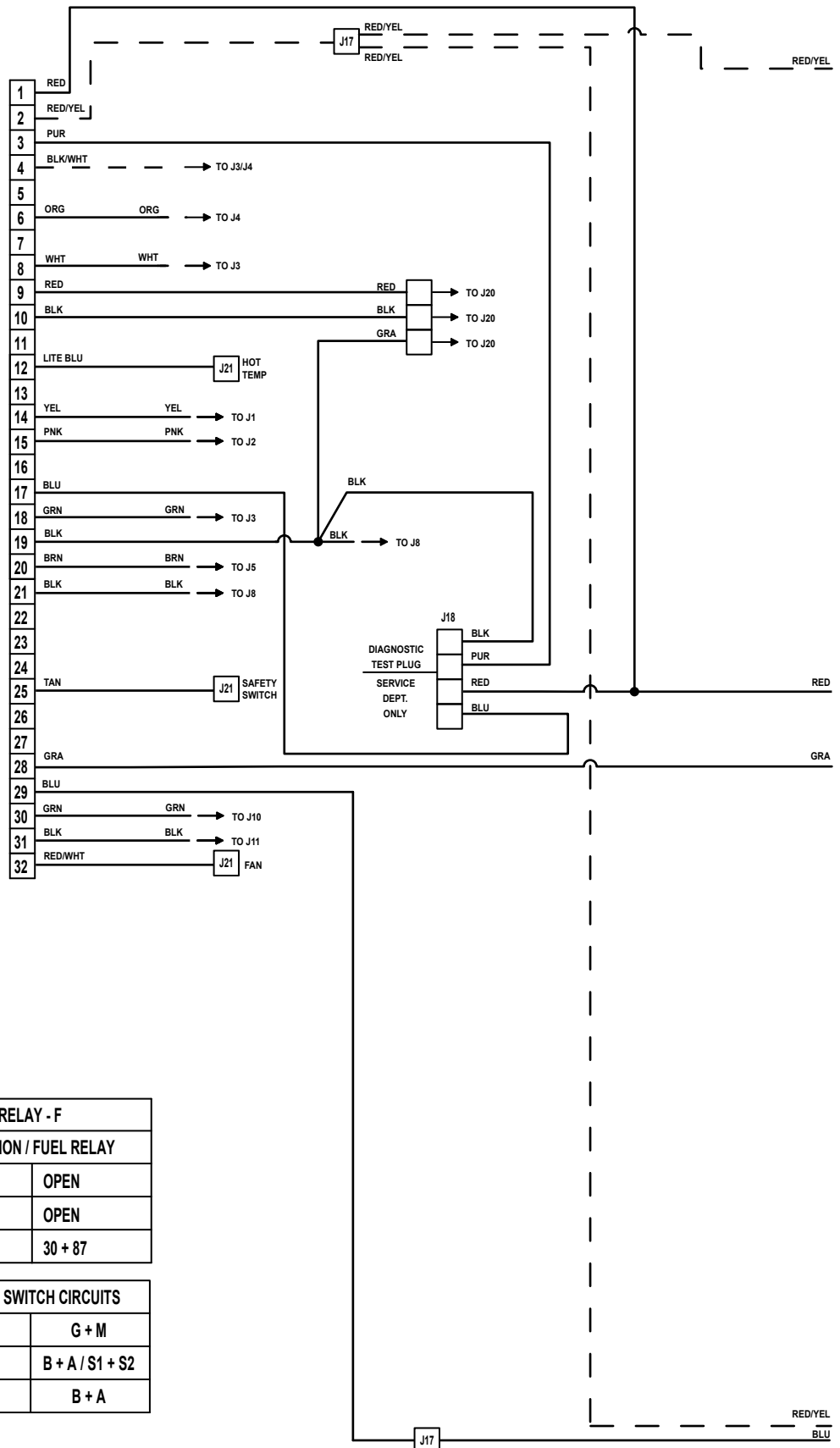

Beginning S/N 124884  
Effective Date 10-07-13

Use only genuine Walker® replacement parts.

# WIRING SCHEMATIC

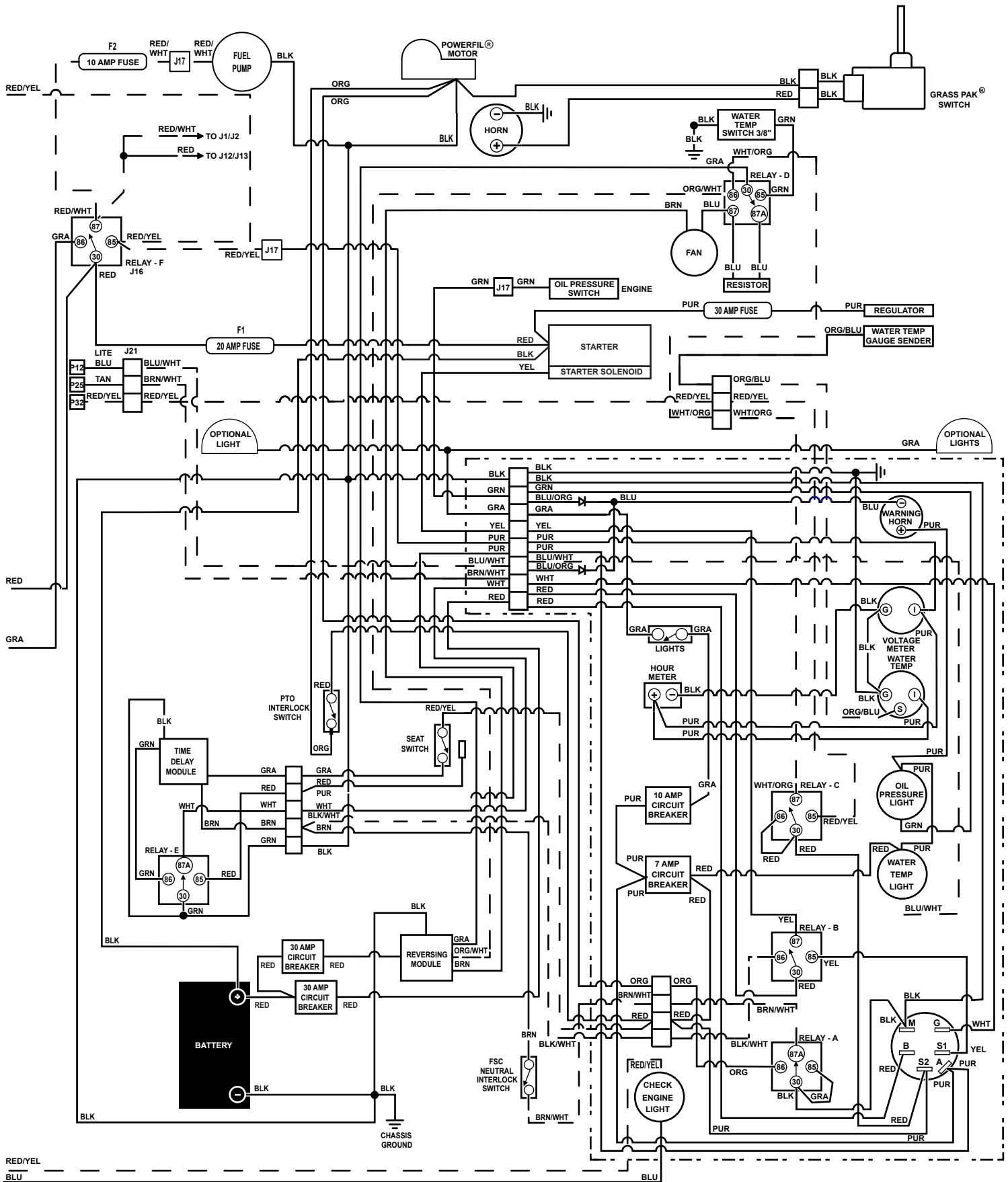

Beginning S/N 124884  
 Effective Date 10-07-13  
 Use only genuine **Walker**® replacement parts.

# OPERATOR'S NOTES

---

# LIMITED WARRANTY FOR WALKER COMMERCIAL RIDER MOWER

## 1. WHAT THIS WARRANTY COVERS, AND FOR HOW LONG:

Walker Manufacturing company will, at its option, repair or replace, without charge, any part covered by this warranty which is found to be defective in material and/or workmanship within one (1) year\* after date of sale to the original retail purchaser unless the product is used for rental purposes, in which case this warranty is limited to ninety (90) days. At Walker's request, customer will make the defective part available for inspection by Walker and/or return the defective part to Walker, transportation charges prepaid. All parts and components of the Walker Mower are covered by this warranty **except** the following components which are warranted separately by their respective manufacturers:

Kohler Engine  
Battery

The available warranties covering these items are furnished with each mower. Walker does not assume any warranty obligation, liability or modification for these items, which are covered exclusively by the stated warranty of the respective manufacturers noted above.

\* Extended warranties are offered for the following powertrain components:

- A three (3) year unlimited hour warranty is offered for the Walker P/N 6200-9 Gear Axle Assembly.
- A three (3) year or 3000 hour (whichever comes first) warranty is offered for Eaton Model 7 Hydrostatic transmissions; covers full cost of replacement up to 1000 hours of use, and after 1000 hours warranty coverage is prorated against 3000 hours.

## 2. WHAT THIS WARRANTY DOES NOT COVER:

- A. This warranty does not cover defects caused by depreciation or damage caused by normal wear, accidents, improper maintenance, improper use or abuse of the product, alterations, or failure to follow the instructions contained in the Operator's Manual for operation and maintenance.
- B. The customer shall pay any charges for making service calls and/or for transporting the mower to and from the place where the inspection and/or warranty work is performed.

## 3. HOW TO OBTAIN SERVICE UNDER THIS WARRANTY:

Warranty service can be arranged by contacting the dealer where you purchased the mower or by contacting Walker Manufacturing Company, 5925 East Harmony Road, Ft. Collins, CO 80528. Proof of the date of purchase may be required to verify warranty coverage.

## 4. WARRANTY LIMITATION:

- A. **THERE IS NO OTHER EXPRESS WARRANTY. ANY WARRANTY THAT MAY BE IMPLIED FROM THIS PURCHASE INCLUDING MERCHANTABILITY AND FITNESS FOR A PARTICULAR PURPOSE IS HEREBY LIMITED TO THE DURATION OF THIS WARRANTY AND TO THE EXTENT PERMITTED BY LAW ANY AND ALL IMPLIED WARRANTIES ARE EXCLUDED.** Some states do not allow limitations on how long an implied warranty lasts, so the above limitations may not apply to you.
- B. **WALKER WILL NOT BE LIABLE FOR ANY INCIDENTAL, CONSEQUENTIAL, OR SPECIAL DAMAGES AND/OR EXPENSES IN CONNECTION WITH THE PURCHASE OR USE OF THE MOWER.** Some states do not allow the exclusion or limitation of incidental or consequential damages, so the above limitation(s) or exclusion(s) may not apply to you.
- C. Only the warranty expressed in this limited warranty shall apply and no dealer, distributor, or individual is authorized to amend, modify, or extend this warranty in any way. Accordingly, additional statements such as dealer advertising or presentations, whether oral or written, do not constitute warranties by Walker, and should not be relied upon.
- D. This warranty gives you specific legal rights, and you may also have other rights which vary from state to state.

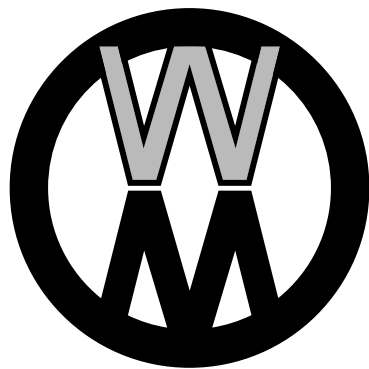

**WALKER**

**WALKER MFG. CO. • 5925 E. HARMONY ROAD, FORT COLLINS, CO 80528 • (970) 221-5614**  
**FORM NO. 100713      PRINTED IN USA      [www.walkermowers.com](http://www.walkermowers.com)      ©2015 WALKER MFG. CO**