



# WALKER

## Illustrated Parts Manual

### *T25i*



Beginning S/N: 125598  
Effective Date: 11.18.13  
P/N 8000-18

# KEY TO ABBREVIATIONS USED IN THIS MANUAL

<i>Abbreviation</i>	<i>What it Represents</i>
° (Dimension)	Degrees (Angle)
" (Dimension)	inches
(-)	Negative (Polarity)
(+)	Positive (Polarity)
AT	All-Terrain
CCW	Counter-clockwise
Conn	Connector
CW	Clockwise
D	Diameter
DC	Deck, Collection (number refers to size in inches)
DM	Deck, Mulching (number refers to size in inches)
DR	Deck, Rear Discharge (number refers to size in inches)
DS	Deck, Side Discharge (number refers to size in inches)
DU	Garlock (Bearing)
ESNA (Fastener)	Nylon Insert Locknut
FSC	Forward Speed Control
GA	Gauge
gal	gallon
GHS	Grass Handling System
GR (Fastener)	Grade
HD	Heavy Duty
HP	Horse Power
ID	Identification or Inside Diameter
L	Length
LH	Left Hand (orientated with operator on seat)
LP	Low Profile
mm (Dimension)	millimeters
MS (Fastener)	Machine Screw
NS (as part number)	Item is not sold by Walker Manufacturing
OD	Outside Diameter
oz	ounce
PFH (Fastener)	Phillips Flat Head
P/N	Part Number
PPH (Fastener)	Phillips Pan Head
PTH (Fastener)	Phillips Truss Head
PTO	Power Take-Off
QKS	Quick Slide
qt	quart
RH	Right Hand (orientated with operator on seat)
SAE (Fastener)	Society of Automotive Engineers
SBH (Fastener)	Socket Button Head (Bolt)
SD	Side Discharge
SFH (Fastener)	Slotted Flat Head
SHC (Fastener)	Socket Head Cap
SHL (Fastener)	Shoulder (Bolt)
SM (Fastener)	Sheet Metal (Screw)
S/N	Serial Number
Spg	Spring
SQH (Fastener)	Square Head
SS (Fastener)	Stainless Steel
ST (Fastener)	Self-Tapping (Screw)
Term	Terminal
V	Volts

**NOTE:** In some instances, combinations of abbreviations may be used (e.g. PPHMS - Phillips Pan Head Machine Screw).

Beginning S/N 125598

Effective Date 11-18-13

Use only genuine **Walker®** replacement parts.

# ILLUSTRATED PARTS LIST

<i>Section of Tractor Covered</i>	<i>Page</i>	<i>Section of Tractor Covered</i>	<i>Page</i>
<b>Decals</b>		<b>Electrical Components</b>	
Tractor Decals .....	2	Electrical Assembly .....	34
<b>Body / Chassis Assemblies</b>		Electrical Assemblies (GHS 10.0 Bushel Components).....	36
Body / Chassis Assembly (GHS Models) .....	4	Electrical Connectors.....	38
Rear Body Assembly (GHS Models) .....	6	<b>Maintenance</b>	
Body Assembly (SD Models).....	8	Lubrication Points .....	40
<b>Tractor Components</b>		Wiring Schematic.....	42
Main Component Power Transmission		Maintenance And Service Record Sheet.....	43
(GHS Models) .....	10	<b>Operator's Notes</b> .....	44
(SD Models) .....	12	<b>Warranty</b>	
Engine Group.....	14	Limited Warranty .....	45
Engine Group (Fuel Components) .....	16		
Hydrostatic Ground Drive Assemblies.....	18		
Steering Control Assemblies.....	20		
Throttle Control Assembly.....	22		
Parking Brake Assembly .....	24		
GHS Group .....	26		
GHS Powerfil® Assembly .....	28		
GHS 10.0 Bushel Catcher Assembly.....	30		
Instrument Panel Assembly .....	32		

# TRACTOR DECALS

ITEM NO.	PART NO.	DESCRIPTION	LOCATION	NO. REQ'D. GHS	NO. REQ'D SD
<b>Walker Product and Operation Decals</b>					
1	8600-33	RH Fender	Body, RH Side Near Seat	1	1
2	5800	Walker Mower (4" Round)	Utility Bed (one on each side)	0	2
3	5800-11	Walker (8" Round)	10.0 Bushel Catcher (one on each side)	2	0
4	5856-1	Made in USA	Body	1	1
<b>Danger Decals Warning Decals Caution Decals</b>					
5	8600-34	Warning, Read Manual	Body	1	1
6	5810-3	Decal, Hydro Warning	Bridge Assembly and LH Gear Axle Drive Assembly	2	2
7	8600-12	Danger, Engine Exhaust	Front Body, LH Side	1	1
8	8600-10	Danger, Pinch Point	10.0 Bushel Catcher Mounting Frame Assembly (one on each side)	2	0
9	8600-4	Danger, Rotating Blower Blades	Body, Near Body Chute	1	0
<b>Maintenance Decals</b>					
10	8600-30	Parking Brake	Body, RH Side Below Seat	1	1
11	8600-23	Body Latch Decal	Body, RH Side Below Seat	1	1
12	5082-5	Fuel Recommendations	Precleaner Tube	1	1
13	5855	Important, Engine Cooling	Engine	1	1
14	5869	Removable Screen	10.0 Bushel Catcher Removable Screen	1	0
15	8600-16	Front Body Closure	Rear Cross Member, Body	1	1
16	7827	Oil Level	Jackshaft Support	1	1
17	5810-1	Axle Oil Level	Gear Axle Drive Assemblies (one on each)	2	2
18	8600-31	Throttle	Body, LH Side	1	1
19	8821-11	Decal, T25i	Body	1	1
20	6875	PTO Alignment Arrow	Universal Joint Tube Assembly	1	1
21	NS	Sealed Reservoir	Hydrostatic Drives (one on each)	2	2

**NOTE:** All parts requiring decals are shipped with decals applied.



## BODY / CHASSIS ASSEMBLY (GHS MODELS)

ITEM NO.	PART NO.	DESCRIPTION	NO. REQ'D	ITEM NO.	PART NO.	DESCRIPTION	NO. REQ'D
<b>Seat Assembly</b>				46	8037	Bearing Cone (3/4 ID)	4
1	5103	Seat	1	47	8035	Tail Wheel & Tire Assembly (13 x 5.00-6) (With Bearing Race)	2
2	7203	Seat Spring Plate	1		7035-1	Tail Wheel Tire (13 x 5.00-6)	**
3	7223-1	Compression Spring	2		8036	Wheel & Hub (6 x 3.25) (Includes Items # 42 & Bearing Race)	**
4	7845-1	Rubber Bumper (1.375 x .750)	2		8037-2	Bearing Race	**
5	7846	Washer (3/8 ID x 1-1/4 OD x 1/8)	2	48	8768-2	Seal, Reverse Lip	2
6	5841-1	Retainer Washer	2	49	8038	Tail Wheel Axle (3/4 x 10-3/8)	1
7	7440-5	Shock Mount (1-1/4 x 3/4)	2	50	7070	Wheel & Tire Assembly (18 x 9.50-8)	2
<b>Rear Bumper Assembly (GHS Models Only)*</b>					7070-1	Drive Tire (18 x 9.50-8)	**
8	7516	GHS Rear Bumper	1		5070-4	Wide Wheel (8 x 7)	**
9	7516-5	Catcher Pivot Bushing	2	51	8300-16	Chassis Frame (EFI / 5.0 gal.)	1
10	5162	Roller Wheel (5" Rubber)	2	<b>Fasteners</b>			
11	7517-2	Catcher Pivot Plate	2		F002	10-24 Keps Nut	2
<b>Body Assembly</b>					F004	1/4-20 Keps Nut	2
12	NS	Body ID Plate	1		F005	1/4-20 ESNA Nut	1
13	5989-12	Dome Plug (3/16)	1		F009	5/16-18 Whiz Locknut	12
14	5989-10	Dome Plug (9/16)	1		F012	3/8-16 Keps Nut	8
15	5845	Rubber Bumper (1.50 OD x 1.25)	4		F013	3/8-16 Whiz Locknut	2
16	8118	Heat Deflector	1		F014	3/8-16 ESNA Nut	4
17	7422	Panel Guard	1		F020	5/16-18 ESNA Nut	1
18	5989-4	Dome Plug (3/8)	4		F025	10-24 x 3/8 PPHMS	2
19	5989-3	Dome Plug (5/16)	2		F029	1/4-20 x 1/2 Hex Bolt	2
20	5146	10mm Ball Stud	2		F031	1/4-20 x 5/8 Hex Bolt	1
21	7844	Rubber Bumper (1.25 OD x .250)	1		F034	5/16-18 x 3/4 Hex Bolt	2
22	2145	Gas Spring	1		F038	3/8-16 x 1 Hex Bolt	6
23	7222	Extension Spring (1/4 x 3)	1		F040	3/8-16 x 1-1/2 Hex Bolt	2
24	7383-3	Body Latch Hook (2-1/2 Side Bars)	1		F042	3/8-16 x 2-1/4 Hex Bolt	2
25	7854	Plastic Tip, Red	1		F050	1/4 SAE Washer	1
26	5989-9	Dome Plug (1/4)	8		F051	3/8 SAE Washer	2
27	8100-5	Front Body	1		F059	3/8 Wave Spring Washer	2
28	5180	Edge Molding, Lever Opening	2		F093	5/16-18 x 1 Hex Bolt	1
29	5989-55	Dome Plug (1/2)	1		F151	3/8-16 x 7/8 Hex Bolt	2
30	5989-5	Dome Plug (7/16)	1		F157	1/2-20 x 1-1/4 Wheel Lug Bolt	8
<b>Tilt-Up Latch Assembly***</b>					F205	5/16-18 x 1/4 Set Screw, Knurl Point	2
31	5847	Plastic Tip	1		F206	#2 x 3/16 Drive Pin	2
32	5744-20	Spring Arm, Tilt-Up Latch	1		F218	7/16 Split Lock Washer	2
33	5744-10	Spring Pivot Bushing	1		F219	7/16-14 x 1-1/4 Hex Bolt	2
34	5744-15	Compression Spring (3/8 x 5/8)	1		F227	3/8 x 1-1/4 x 1/8 Plastic Washer	2
35	5744-13	Mount Angle, LH	1		F241	.375 x .875 x .10 Washer	4
36	5744-12	Hook, Tilt-Up Latch	1		F257	3/8 x 1-11/16 Shoulder Bolt	2
37	5744-14	Mount Angle, RH	1		F341	Coil Roll Pin (7/64 x 9/16)	1
<b>Chassis Assembly</b>					F342	5/16 Conical Washer	2
38	5267-1	Retainer Collar (1") (Includes Item # F413)	1		F413	5/16-24 x 5/16 Set Screw	2
39	5270-1	Pivot Bearing	2	*	Rear Bumper Assembly for SD Models is not shown here. Refer to <b>BODY ASSEMBLY (SD MODELS)</b> , Page 8.		
40	5842-1	Washer (1.0 ID x 1.350 OD)	1	**	Service Part Only		
41	7420	Tail Wheel Fork	1	***	Complete Tilt-Up Latch Assembly Kit available by ordering kit # 5747.		
42	5830-3	Grease Fitting (45 Degree)	2				
43	8039	Nut, Tail Wheel Axle	2				
44	8037-1	Seal, Outer (1-3/4 x 1-1/8)	2				
45	8038-1	Spacer, Tail Wheel Axle (.750 x ID x 1.125 OD)	2				

Beginning S/N 125598

Effective Date 11-18-13

Use only genuine **Walker**® replacement parts.

# BODY / CHASSIS ASSEMBLY (GHS MODELS)

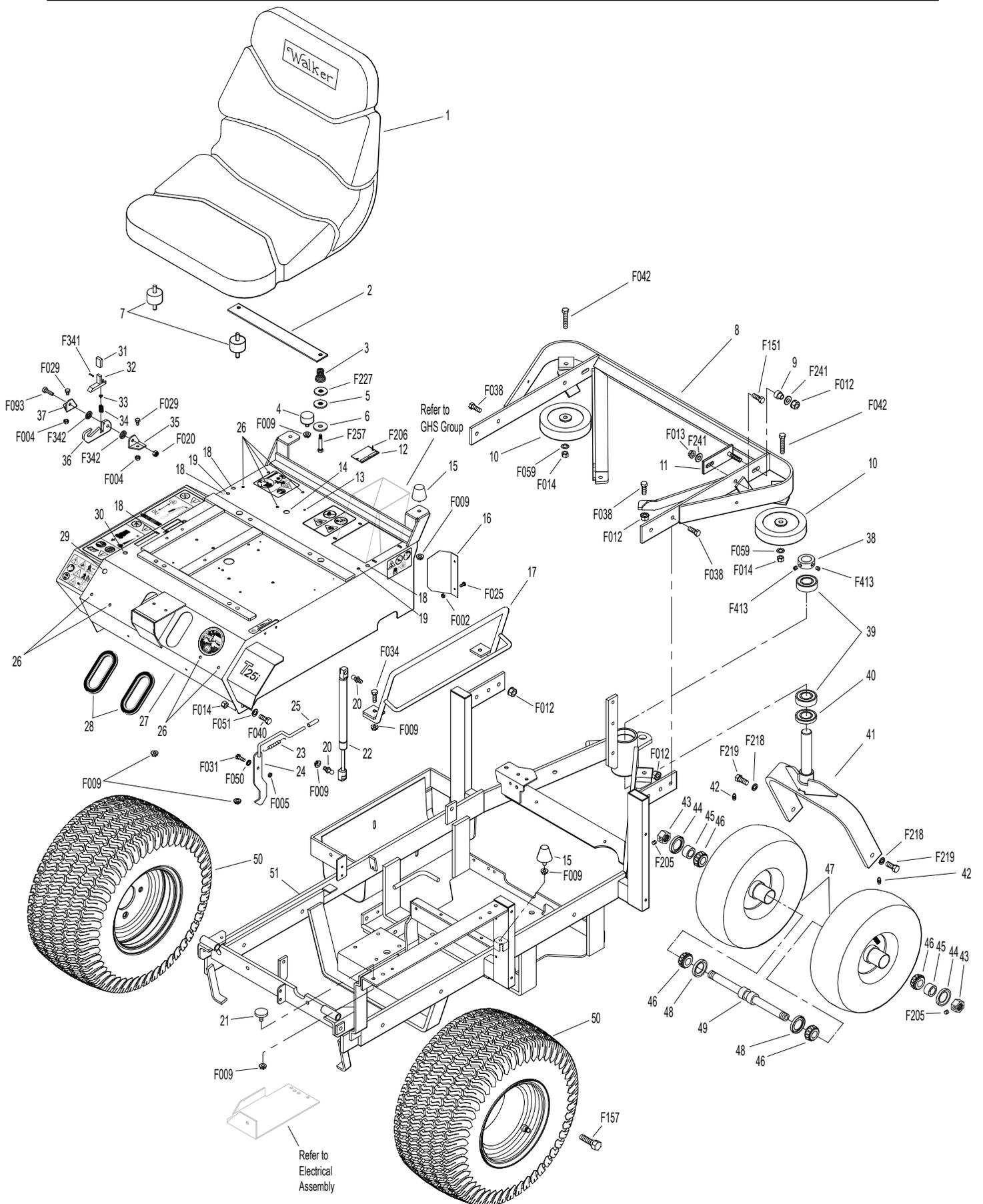

Beginning S/N 125598  
 Effective Date 11-18-13  
 Use only genuine **Walker**® replacement parts.

## REAR BODY ASSEMBLY (GHS MODELS)

ITEM NO.	PART NO.	DESCRIPTION	NO. REQ'D	ITEM NO.	PART NO.	DESCRIPTION	NO. REQ'D
<b>Rear Body Assembly (GHS Models)</b>				<b>Fasteners</b>			
1	7190-3	Insulation Foam Pad (5 x 20)	1	F002		10-24 Keps Nut	14
2	8082	Heat Shield	1	F004		1/4-20 Keps Nut	5
3	8515-14	Catcher Handle Plate, RH	1	F009		5/16-18 Whiz Locknut	2
4	8515-13	Catcher Handle Plate, LH	1	F025		10-24 x 3/8 PPHMS	8
5	8615-3	Catcher Support Frame, 10.0	1	F026		10-24 x 1/2 PPHMS	5
6	7190-2	Insulation Foam Pad, RH	1	F027		10-24 x 5/8 PPHMS	1
7	7190-1	Insulation Foam Pad, LH	1	F031		1/4-20 x 5/8 Hex Bolt	2
8	5832	Cable Clamp (1/2)	1	F032		1/4-20 x 3/4 Hex Bolt	1
9	8389-4	Splash Guard	1	F085		3/16 Rivet Backup Washer	2
10	7145	Gas Spring Assembly (Includes Items # 11 & 12)	1	F178		1/4 x 1 Fender Washer	1
11	7147	Spring Clip	2	F390		1/4-20 x 7/8 Carriage Bolt	2
12	7146	13mm Ball Stud	2	<b>NOTE:</b> Rear Bumper Assembly for GHS Models is not shown here. Refer to <b>BODY / CHASSIS ASSEMBLY (GHS MODELS)</b> , Page 4.			
13	8105-1	Rear Body Panel	1				

# REAR BODY ASSEMBLY (GHS MODELS)

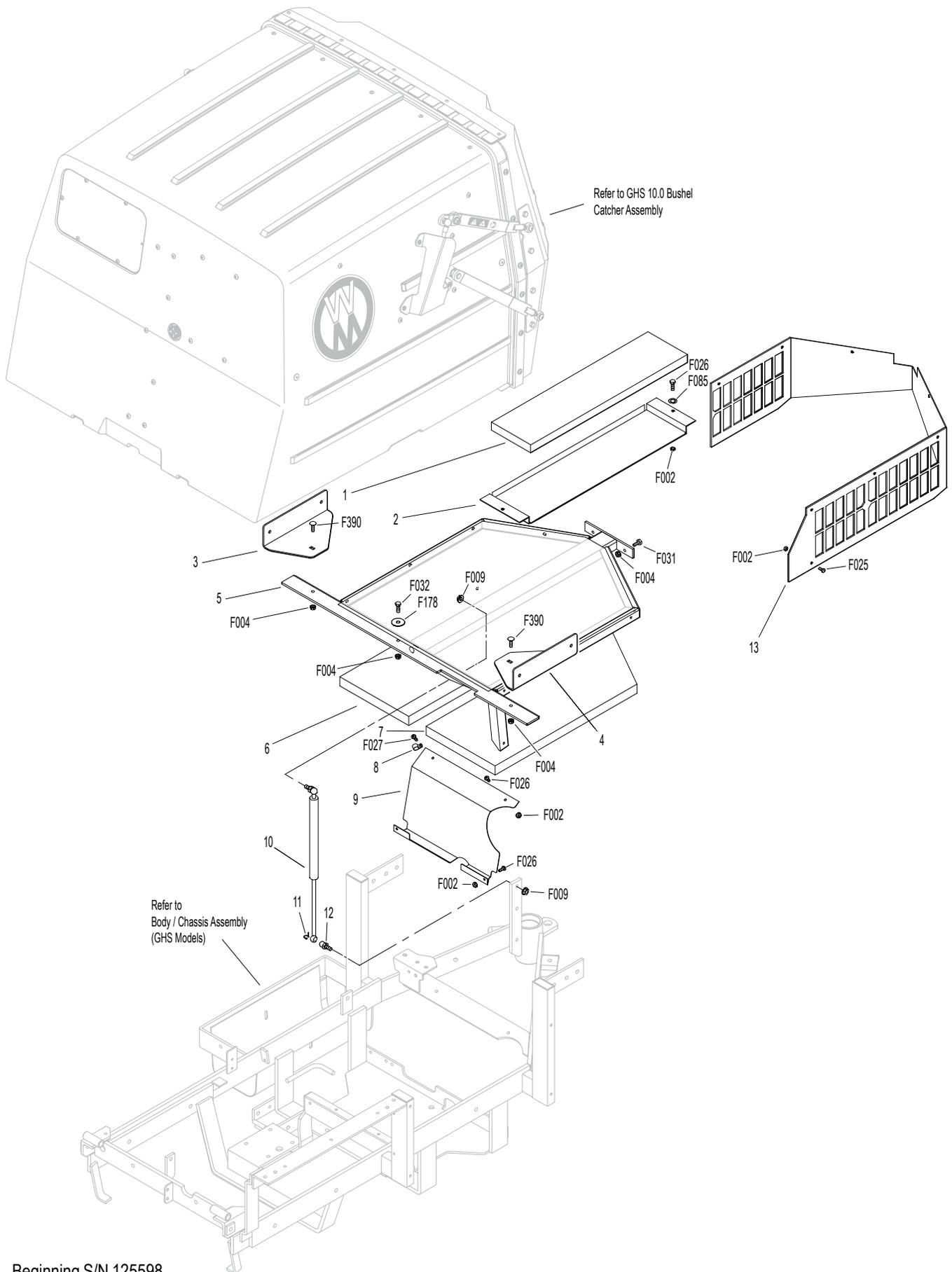

Beginning S/N 125598  
Effective Date 11-18-13  
Use only genuine **Walker**® replacement parts.

## BODY ASSEMBLY (SD MODELS)

ITEM NO.	PART NO.	DESCRIPTION	NO. REQ'D	ITEM NO.	PART NO.	DESCRIPTION	NO. REQ'D
<b>Utility Bed Assembly</b>				<b>Fasteners</b>			
1	8650-10	Bed Liner (21.5 x 27.5)	1	F002		10-24 Keps Nut	16
2	8650-2	Utility Bed (Includes Item # 1)	1	F009		5/16-18 Whiz Locknut	2
3	7190-2	Insulation Foam Pad, RH	1	F012		3/8-16 Keps Nut	6
4	7190-1	Insulation Foam Pad, LH	1	F013		3/8-16 Whiz Locknut	4
<b>Rear Bumper Assembly (SD Models)</b>				F014		3/8-16 ESNA Nut	2
5	7153-3	Cover Plate	1	F025		10-24 x 3/8 PPHMS	8
6	7145	Gas Spring Assembly (Includes Item # 7)	1	F026		10-24 x 1/2 PPHMS	3
7	7146	13mm Ball Stud	2	F027		10-24 x 5/8 PPHMS	1
8	7521	Rear Bumper	1	F038		3/8-16 x 1 Hex Bolt	6
9	5162	Roller Wheel (5" Rubber)	2	F040		3/8-16 x 1-1/2 Hex Bolt	2
10	8105-1	Rear Body Panel	1	F042		3/8-16 x 2-1/4 Hex Bolt	2
11	8389-2	Splash Guard with Mat (Includes Item # 12)	1	F051		3/8 SAE Washer	4
12	8389-12	Rubber Mat (3 x 3)	1	F059		3/8 Wave Spring Washer	2
				F128		10-24 x 3/8 PTHMS	4

**NOTE:** Refer to **BODY / CHASSIS ASSEMBLY (GHS MODELS)**,  
Page 4 for all common parts used on both models.



# MAIN COMPONENT POWER TRANSMISSION (GHS MODELS)

ITEM NO.	PART NO.	DESCRIPTION	NO. REQ'D	ITEM NO.	PART NO.	DESCRIPTION	NO. REQ'D
<b>Clutch Lever Assembly</b>				41	6325-2	Spacer Bushing (5/16)	2
1	8358-3	Clutch Lever (Includes Items # 2 & 3)	1	42	8349-2	Idler Arm	1
2	5830	Grease Fitting	7	43	7201-4	Inner Race (1-1/2)	2
3	4850	Handle Grip, Black	1	44	5221-1	Extension Spring (3/4 x 5)	2
4	7303-10	Clutch Actuator Bolt (3/8)	1	45	8539	Starter Relay Mount	1
5	7380-5	Knuckle Joint (3/8 ID)	1	46	5268	Bearing W/Collar (3/4)	2
6	7226-10	Compression Spring (3/4 x 2-1/2)	1	47	7241-2	Transmission Drive Pulley (3-1/4MV) (Includes Items # F067 & F171)	1
7	8130-5	Pushrod, Clutch Actuator (Threaded Tube) (Includes Item # 2)	1	48	7833	Cable Clamp (7/8 x 1/4)	1
8	8130-10	Clutch Actuator Rod Assembly (Includes Items # 2, 4-7, F054, F336 & F353)	1	49	8349	Transmission Belt Tightener Arm	1
9	7201-3	Fiberglide Bearing	6	50	8393-7 8394-1	Hydro Jackshaft Mount Hydro Jackshaft Mount Assembly (Includes Items # 2, 9, 43, 46, 50 & 51)	1 *
10	7201-5	Inner Race (2-1/4)	1	51	8273	Jackshaft (3/4 x 7-1/2)	1
11	8368	PTO Belt Tightener	1	52	7240-4	Jackshaft Drive Pulley (3.3/3V) (Includes Items # F067 & F171)	1
12	5841	Retainer Washer (3/8 x 1-1/4)	4	<b>Fasteners</b>			
13	8243-1	Clutch Idler Pulley	1	F003	1/4-28 Hex Nut		2
	8243	Clutch Idler Pulley Assembly (Includes Items # 14, 15 & F070)	*	F004	1/4-20 Keps Nut		3
14	5265	Bearing (3/4)	1	F005	1/4-20 ESNA Nut		1
15	8243-3	Hub, Idler Pulley	1	F009	5/16-18 Whiz Locknut		3
16	8375	PTO Belt Tightener Stop	1	F012	3/8-16 Keps Nut		7
17	7377	Plastic Washer (1 x .438 x .025)	2	F029	1/4-20 x 1/2 Hex Bolt		1
18	7378	Pivot Bearing (7/16 x 9/16)	1	F040	3/8-16 x 1-1/2 Hex Bolt		1
19	5281-1	Clevis Spring Pin	1	F041	3/8-16 x 1-3/4 Hex Bolt		2
20	5280	Clevis (1/4)	2	F042	3/8-16 x 2-1/4 Hex Bolt		3
21	8305	Brake Actuator Rod	1	F043	3/8-16 x 3 Hex Bolt		1
22	8370	Bearing, Brake Actuator	1	F047	3/8-16 x 4-1/2 Hex Bolt		1
23	5281-5	Clevis Pin (1/4 x 0.80)	1	F054	AN960616 Washer		3
24	8250	Brake Spring (1/2 x 2-1/2)	1	F061	1/4 Internal Star Lock Washer		1
25	8369	Brake Actuator (Includes Items # 2 & 22)	1	F067	3/16 x 3/16 x 1 Key		2
<b>PTO Drive Shaft Assembly</b>				F069	3/32 x 1/2 Cotter Pin		1
26	7050-1	Dipstick, Gearbox	1	F070	1-3/4 Internal Snap Ring		1
27	8371-1	Mount Bracket, Brake Band	1	F090	1/4-20 x 2-1/2 Hex Bolt		1
28	8377	Brake Band Guide	1	F116	1/4-20 x 1-1/4 Hex Bolt		1
29	8050-11	PTO Gearbox / Flange Pulley	1	F121	5/16-18 x 3/8 x 1 SHL Bolt		1
30	5245	Idler Pulley (3")	2	F131	5/16-18 x 1/2 Hex Bolt		2
31	7248	Ground Drive Belt, Micro-V	1	F132	1/4-20 x 2-3/4 Hex Bolt		1
32	7275-16	Universal Joint Tube Assembly / Spline	1	F168	5/16 Split Lock Washer		14
33	7275-9	Quick Coupler Installation Tool	1	F171	5/16-18 x 3/8 Set Screw		4
34	7523-2	Clevis Pin W/Hole (1/4 x 5/8)	1	F178	1/4 x 1 Fender Washer		1
35	8304	Brake Band (14-1/2)	1	F182	1/4 x 5/8 x 1/8 Washer		2
36	6250-1	Drive Belt (3VX370)	1	F186	5/64 x 1/2 Cotter Pin		1
37	7236-1	PTO Drive Pulley (4-1/2/3V) (Includes Items # F168 & F226)	1	F226	5/16-18 x 7/8 Hex Bolt		14
38	8237-2	Engine Pulley, Bolt On (4/3.8/3V) (Includes Items # F168 & F226)	1	F241	.375 x .875 x .10 Washer		1
39	8230	Engine PTO Belt	1	F255	5/16-18 x 1-1/2 Hex Bolt		2
<b>Jackshaft Assembly</b>				F261	AN960616L Washer		1
40	7245-1	Idler Pulley (3/8 Groove)	1	F336	3/8-16 Jam Nut		1
				F353	3/8-16 ESNA LP Nut		1
				*	Service Part Only		

Beginning S/N 125598

Effective Date 11-18-13

Use only genuine **Walker**® replacement parts.

# MAIN COMPONENT POWER TRANSMISSION (GHS MODELS)

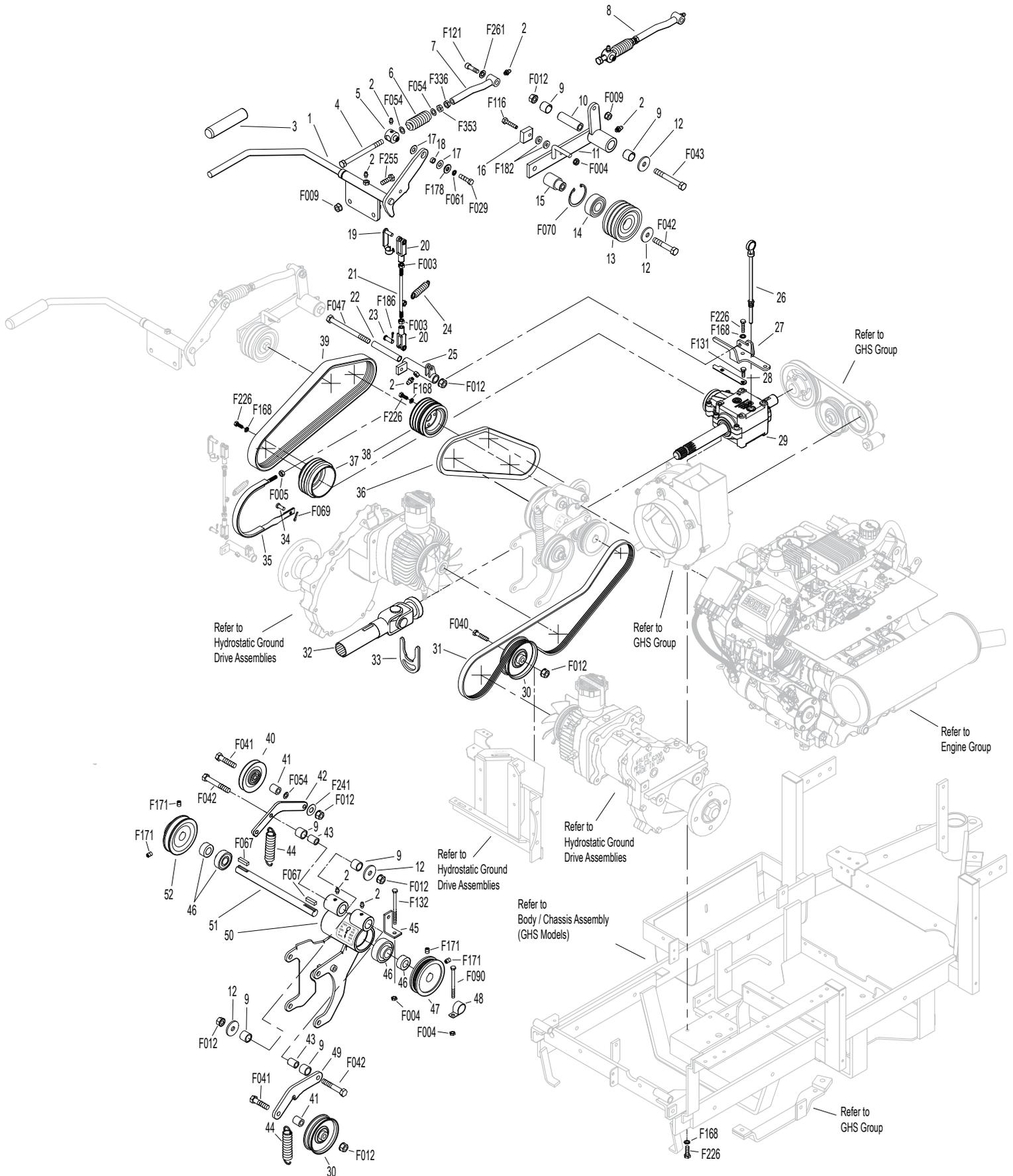

Beginning S/N 125598  
 Effective Date 11-18-13  
 Use only genuine **Walker**® replacement parts.

# MAIN COMPONENT POWER TRANSMISSION (SD MODELS)

ITEM NO.	PART NO.	DESCRIPTION	NO. REQ'D	ITEM NO.	PART NO.	DESCRIPTION	NO. REQ'D
<b>Clutch Lever Assembly</b>				42	8349-2	Idler Arm	1
1	8358-3	Clutch Lever (Includes Items # 2 & 3)	1	43	7201-4	Inner Race (1-1/2)	2
2	5830	Grease Fitting	7	44	5221-1	Extension Spring (3/4 x 5)	2
3	4850	Handle Grip, Black	1	45	8539	Starter Relay Mount	1
4	7303-10	Clutch Actuator Bolt (3/8)	1	46	5268	Bearing W/Collar (3/4)	2
5	7380-5	Knuckle Joint (3/8 ID)	1	47	7241-2	Transmission Drive Pulley (3-1/4MV) (Includes Items # F067 & F171)	1
6	7226-10	Compression Spring (3/4 x 2-1/2)	1	48	7833	Cable Clamp (7/8 x 1/4)	1
7	8130-5	Pushrod, Clutch Actuator (Threaded Tube) (Includes Item # 2)	1	49	7394-6	Idler Pulley Spring Mount	1
8	8130-10	Clutch Actuator Rod Assembly (Includes Items # 2, 4-7, F054, F336 & F353)	1	50	8349	Transmission Belt Tightener Arm	1
9	7201-3	Fiberglide Bearing	6	51	8393-7	Hydro Jackshaft Mount	1
10	7201-5	Inner Race (2-1/4)	1		8394-1	Hydro Jackshaft Mount Assembly (Includes Items # 2, 9, 43, 46, 51 & 52)	*
11	8368	PTO Belt Tightener	1	52	8273	Jackshaft (3/4 x 7-1/2)	1
12	5841	Retainer Washer (3/8 x 1-1/4)	4	53	7240-4	Jackshaft Drive Pulley (3.3/3V) (Includes Items # F067 & F171)	1
13	8243-1	Clutch Idler Pulley	1	<b>Fasteners</b>			
	8243	Clutch Idler Pulley Assembly (Includes Items # 13-15 & F070)	*	F003	1/4-28 Hex Nut		2
14	5265	Bearing (3/4)	1	F004	1/4-20 Keps Nut		3
15	8243-3	Hub, Idler Pulley	1	F005	1/4-20 ESNA Nut		1
16	8375	PTO Belt Tightener Stop	1	F009	5/16-18 Whiz Locknut		3
17	7377	Plastic Washer (1 x .438 x .025)	2	F012	3/8-16 Keps Nut		7
18	7378	Pivot Bearing (7/16 x 9/16)	1	F029	1/4-20 x 1/2 Hex Bolt		1
19	5281-1	Clevis Spring Pin	1	F040	3/8-16 x 1-1/2 Hex Bolt		1
20	5280	Clevis (1/4)	2	F041	3/8-16 x 1-3/4 Hex Bolt		2
21	8305	Brake Actuator Rod	1	F042	3/8-16 x 2-1/4 Hex Bolt		3
22	8370	Bearing, Brake Actuator	1	F043	3/8-16 x 3 Hex Bolt		1
23	5281-5	Clevis Pin (1/4 x 0.80)	1	F047	3/8-16 x 4-1/2 Hex Bolt		1
24	8250	Brake Spring (1/2 x 2-1/2)	1	F054	AN960616 Washer		3
25	8369	Brake Actuator (Includes Items # 2 & 22)	1	F061	1/4 Internal Star Lock Washer		1
<b>PTO Drive Shaft Assembly</b>				F067	3/16 x 3/16 x 1 Key		2
26	7050-1	Dipstick, Gearbox	1	F069	3/32 x 1/2 Cotter Pin		1
27	8371-1	Mount Bracket, Brake Band	1	F070	1-3/4 Internal Snap Ring		1
28	8377	Brake Band Guide	1	F090	1/4-20 x 2-1/2 Hex Bolt		2
29	8050-11	PTO Gearbox / Flange Pulley	1	F116	1/4-20 x 1-1/4 Hex Bolt		1
30	5245	Idler Pulley (3")	2	F121	5/16-18 x 3/8 x 1 SHL Bolt		1
31	7248	Ground Drive Belt, Micro-V	1	F131	5/16-18 x 1/2 Hex Bolt		2
32	7275-16	Universal Joint Tube Assembly / Spine	1	F168	5/16 Split Lock Washer		14
33	7275-9	Quick Coupler Installation Tool	1	F171	5/16-18 x 3/8 Set Screw		4
34	7523-2	Clevis Pin W/Hole (1/4 x 5/8)	1	F178	1/4 x 1 Fender Washer		1
35	8304	Brake Band (14-1/2)	1	F182	1/4 x 5/8 x 1/8 Washer		2
36	6250-1	Drive Belt (3VX370)	1	F186	5/64 x 1/2 Cotter Pin		1
37	7236-1	PTO Drive Pulley (4-1/2/3V) (Includes Items # F168 & F226)	1	F226	5/16-18 x 7/8 Hex Bolt		14
38	8237-2	Engine Pulley, Bolt On (4/3.8/3V) (Includes Items # F168 & F226)	1	F241	.375 x .875 x .10 Washer		1
39	8230	Engine PTO Belt	1	F255	5/16-18 x 1-1/2 Hex Bolt		2
<b>Jackshaft Assembly</b>				F261	AN960616L Washer		1
40	7245-1	Idler Pulley (3/8 Groove)	1	F336	3/8-16 Jam Nut		1
41	6325-2	Spacer Bushing (5/16)	2	F353	3/8-16 ESNA LP Nut		1
				*	Service Part Only		

Beginning S/N 125598

Effective Date 11-18-13

Use only genuine **Walker**® replacement parts.



# ENGINE GROUP

ITEM NO.	PART NO.	DESCRIPTION	NO. REQ'D	ITEM NO.	PART NO.	DESCRIPTION	NO. REQ'D
<b>Precleaner Assembly</b>				35	8013-2	Upright Support	1
1	7026-2	Remote Precleaner (Includes Item # 2)	1	36	8013-13	Muffler Heat Shield	1
2	7840	Hose Clamp (1-5/16 to 2-1/4)	4	37	8013-61	Muffler Heat Deflector W/Knurled Inserts	1
3	7028-5	Precleaner Tube (1-3/4)	1	38	8013-29	Muffler Heat Shield Endcap	1
4	7440	Shock Mount (1 x 3/4)	3	39	8013-18	Muffler Brace	1
5	7028-20	Rear Precleaner Mount	1	40	8021	Engine Brace	1
6	8026-17	Air Intake Hose	1	<b>Fasteners</b>			
7	6090-11	Air Cleaner Assembly (Includes Items # 10-14, 16 & 17)	*	F002	10-24 Keps Nut		2
8	7027	Elbow, Precleaner	1	F004	1/4-20 Keps Nut		7
9	6029	Hose Clamp (1-3/4 to 2-1/4)	1	F009	5/16-18 Whiz Locknut		11
10	5090-3	Safety Filter Insert	1	F012	3/8-16 Keps Nut		4
11	5090-1	Air Cleaner Cartridge	1	F025	10-24 x 3/8 PPHMS		2
12	5088-5	Air Cleaner Draw Latch	2	F026	10-24 x 1/2 PPHMS		3
13	5088-11	Air Cleaner Cap (Includes Item # 12)	1	F029	1/4-20 x 1/2 Hex Bolt		4
14	5090-2	Vacuator Valve	1	F031	1/4-20 x 5/8 Hex Bolt		3
15	5088-1	Air Cleaner Band	1	F038	3/8-16 x 1 Hex Bolt		3
16	5091-0	1/8 Pipe Thread Male W/Barb	1	F050	1/4 SAE Washer		3
17	5091-9	Street Elbow 90° (1/8 x 1/8)	1	F052	5/16 External Star Lock Washer		2
18	M258	Vacuum Hose (7")	1**	F053	7/16 Int. Star Lock Washer		2
19	5091-6	Air Flow Indicator W/Bracket	1	F061	1/4 Internal Star Lock Washer		2
20	7031-2	Tube Support Arm	1	F063	3/8 Internal Star Lock Washer		2
<b>Engine Assembly</b>				F090	1/4-20 x 2-1/2 Hex Bolt		2
21	5845	Rubber Bumper (1.50 x 1.25)	1	F091	5/16-18 x 5/8 Hex Bolt		2
22	8010-2	Engine Bumper Mount	1	F106	3/8-16 x 5/8 Hex Bolt		2
23	NS	Oil Filter (Kohler 1205001)	1	F120	AN960416 Washer		2
24	NS	25-hp EFI Engine	1	F129	10-24 x 1/2 PTHMS		1
<b>Remote Oil Cooler Assembly</b>				F132	1/4-20 x 2-3/4 Hex Bolt		1
25	NS	Clamp (Kohler 25 237 02-S)	4	F140	7/16-14 x 1 Hex Bolt		2
26	NS	Oil Cooler Hose (Kohler 24326127)	2	F175	1/2 Split Lock Washer		4
27	NS	Oil Cooler (Kohler 24 594 12-S)	1	F255	5/16-18 x 1-1/2 Hex Bolt		2
28	8016-7	Oil Cooler / Regulator Mount	1	F256	7/16 SAE Washer		2
<b>Exhaust Assembly</b>				F273	M6 x 1.0 Nut		4
29	8530-9	Grass Shield, Muffler (EFI) (Includes Items # F002 & F025)	1	F274	M6 x 1.0 x 45 Stud		2
30	NS	Screw (Kohler M645016-S)	2	F285	1/2-13 x 1-1/2 Hex Bolt		4
31	NS	Sensor, Oxygen (Kohler)	1	F324	M8 x 1.25 x 12 Hex Bolt		2
32	NS	Gasket (Kohler)	2	F482	8-32 Nylock Nut		2
33	NS	Nut (Kohler M-0841080)	4	F483	8-32 x 3/4 PPHMS		2
34	8013-11	Muffler (EFI)	1	* Service Part Only			
				** <b>Required hose specifications:</b> M258 - 7/64" ID automotive vacuum hose			
				<b>NOTE:</b> Refer to Kohler Engine Decal (NS) for Engine Identification Numbers.			

# ENGINE GROUP

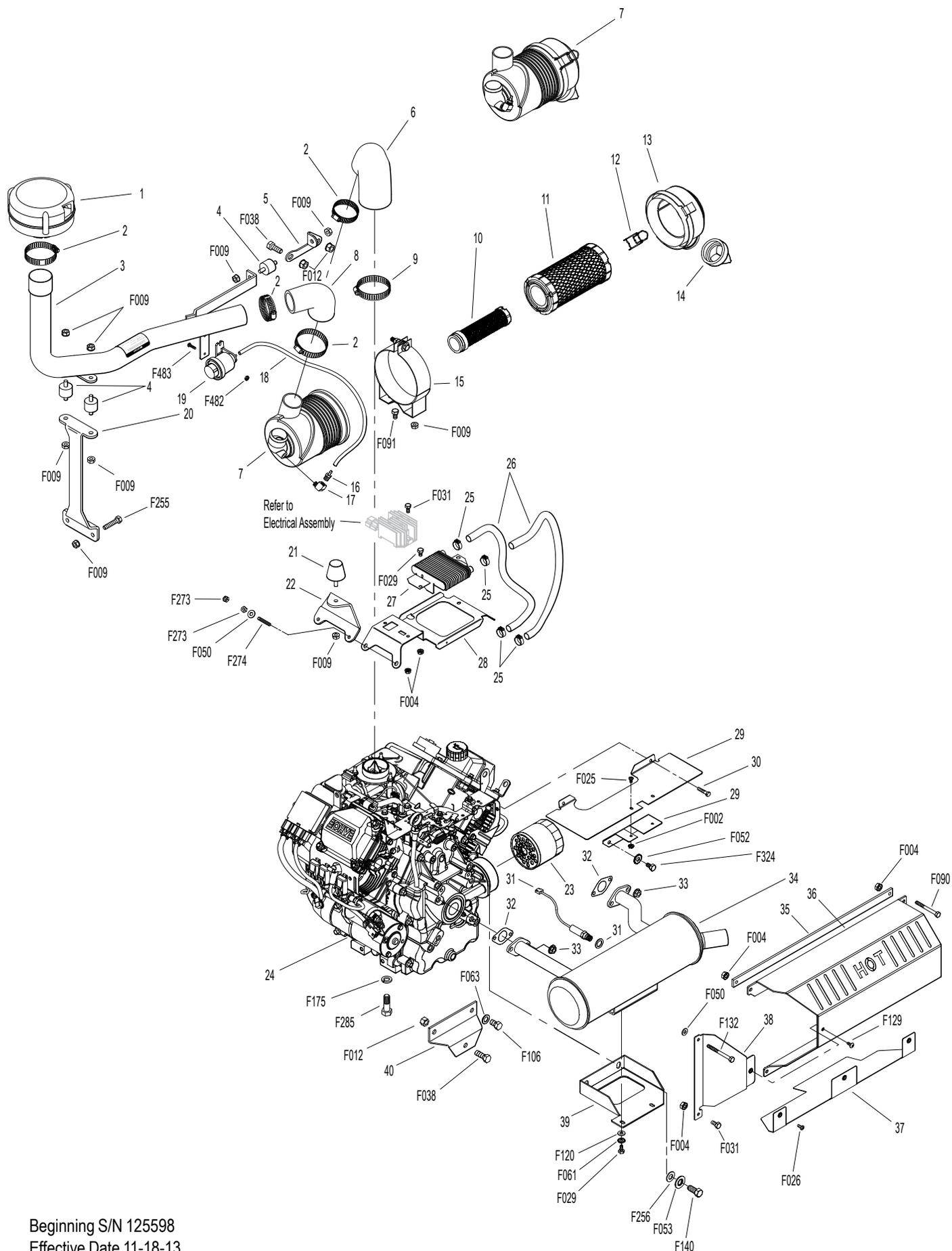

Beginning S/N 125598  
 Effective Date 11-18-13  
 Use only genuine **Walker**® replacement parts.

## ENGINE GROUP (FUEL COMPONENTS)

ITEM NO.	PART NO.	DESCRIPTION	NO. REQ'D	ITEM NO.	PART NO.	DESCRIPTION	NO. REQ'D
<b>Fuel Tank Assembly</b>				<b>Fasteners</b>			
1	8046-3	Fuel Tank, 4.7 Gallon, Gas (Includes Items # 5, 6 & 18)	1	F002		10-24 Keps Nut	3
2	5082-4	2-1/4 Ratchet Fuel Cap	*	F004		1/4-20 Keps Nut	3
3	8043-8	Roll-Over Valve	1	F009		5/16-18 Whiz Locknut	2
4	5977-7	Roll Over Grommet (.900 x 1-1/2)	1	F025		10-24 x 3/8 PPHMS	2
5	5083-1	Bushing, Rubber	1	F029		1/4-20 x 1/2 Hex Bolt	2
6	5879-3	Hose Clamp (1/2)	6	F034		5/16-18 x 3/4 Hex Bolt	2
7	5975-3	Cable Tie (50# x 7")	2	F050		1/4 SAE Washer	3
8	M113	Fuel Line (3/16 x 28")	1**	F061		1/4 Internal Star Lock Washer	2
9	7833	Cable Clamp (7/8 x 1/4)	2	F079		A/A66D Aluminum Pop Rivet	2
10	8018-4	Fuel Module Cover	1	F128		10-24 x 3/8 PTHMS	1
11	8018-1	Fuel Module Bracket	1	F129		10-24 x 1/2 PTHMS	1
12	8018-2	Fuel Bracket Spacer	1	F398		1/4-20 x 2 Hex Bolt	3
13	M113	Fuel Line (3/16 x 12")	1**	* Service Part Only			
14	5879-4	Hose Clamp (7/16)	1	** <b>Required hose specifications:</b>			
15	8046-16	Quick Connector 5/16 x 5/16 - 45°	1	M113 - 3/16" ID fuel/oil/vapor hose (Gates 4219-0093 or equivalent)			
16	8046-14	Quick Connector, Male (5/16)	1	M246 - 1/4" ID low permeation (<15g/m <sup>2</sup> /day) fuel hose (Parker 38904 or equivalent)			
17	M246	Fuel Line (1/4 x 20.5")	1**	M247 - 5/16" ID low permeation (<15g/m <sup>2</sup> /day) fuel hose (Parker 38905 or equivalent)			
18	5879-5	Stepless Ear Clamp (5/8)	2	<b>NOTE:</b> Refer to Kohler Engine Decal (NS) for Engine Identification Numbers.			
19	M247	Fuel Line (5/16 x 6")	1**				
20	NS	Fuel Line, Engine (Kohler)	1				
21	5020	Fuel Filter	*				
22	M246	Fuel Line (1/4 x 23")	1**				
23	8016-6	ECU Mount	1				
24	5086-7	Hose (1/4 x 6")	1				
25	8023	Fuel Tank Support	1				
26	5020-2	Fuel Filter, In Tank	1				

# ENGINE GROUP (FUEL COMPONENTS)

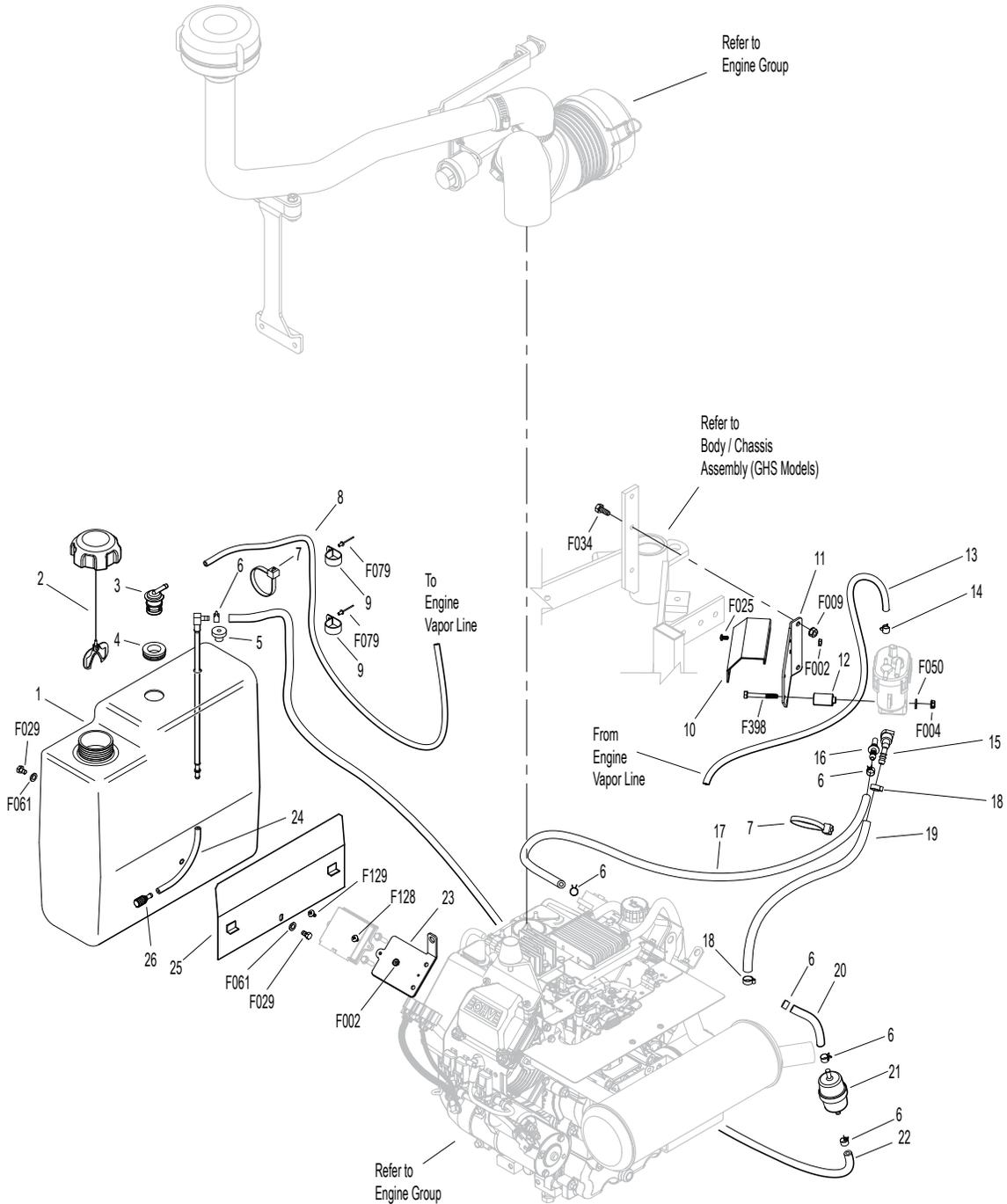

Beginning S/N 125598  
 Effective Date 11-18-13  
 Use only genuine **Walker**® replacement parts.

# HYDROSTATIC GROUND DRIVE ASSEMBLIES

ITEM NO.	PART NO.	DESCRIPTION	NO. REQ'D	ITEM NO.	PART NO.	DESCRIPTION	NO. REQ'D
<b>Transmission Lockout Assembly</b>				<b>Transmission Repair Parts</b>			
1	5028-3	Transmission Lockout Assembly (Includes Items # 2-5, F023, F027 & F081)	*	26	5025-5	Input Shaft	*
2	5847	Plastic Tip	2	27	5025-8	Bearing, Input Shaft	*
3	5057	Lockout Cam (Includes Item # F081)	2	28	5025-7	Snap Ring	*
4	5028-5	Lockout Lever	2	29	5025-2	Seal, Input Shaft	*
5	5027-5	Lockout Mount	1**	30	5022	Reservoir to Casting Gasket	*
<b>Ground Drive Assemblies</b>				31	5024	Reservoir Cap and Gasket	*
6	6209-3	Bridge Assembly	1	32	5023	Transmission Reservoir Kit	*
7	6243-2	Hydro Fan, CCW	1	33	5023-1	Rubber Bladder	*
8	5026	Hydrostatic Drive, CW (700-051)	1	34	5025-6	O-Ring & Plug Assembly	*
9	6206-1	Air Vent Valve	*	35	5025-3	Seal, Control Shaft	*
10	6200-9	Gear Axle Drive Assembly (Includes Items # 9 & 11)	2	<b>Fasteners</b>			
11	6207-12	Pipe Plug (1/4 NPTF)	4	F012	3/8-16 Keps Nut		2
12	5126	Cable Retainer (Uses existing bolt on Gear Axle Drive Assembly)	1	F023	10-24 ESNA Nut		2
13	6233-1	Pinion Gear	2	F027	10-24 x 5/8 PPHMS		2
14	6234	Spacer, Pinion Gear	2	F036	1/4-20 x 1/2 SBH Screw		2
15	6201	O-Ring Seal	2	F038	3/8-16 x 1 Hex Bolt		4
16	7244	Hydro Pulley (3-7/8/MV) (Includes Items # F064 & F359)	2	F040	3/8-16 x 1-1/2 Hex Bolt		4
17	6243-1	Hydro Fan, CW	1	F043	3/8-16 x 3 Hex Bolt		6
18	5025	Hydrostatic Drive, CCW (700-052)	1	F051	3/8 SAE Washer		2
<b>Deck Support Arm Assemblies</b>				F053	7/16 Internal Star Lock Washer		4
19	6430-10	Outboard Mount, LH	1	F063	3/8 Internal Star Lock Washer		14
20	6431-1	Deck Support Arm, LH (Includes Item # 24)	1	F064	1/8 x 1/2 Woodruff Key (#3)		4
21	5775-2	Hitch Pin (# 6)	2	F081	A/A45D Aluminum Pop Rivet		2
22	6431-2	Deck Support Arm, RH (Includes Item # 24)	1	F160	External Snap Ring (.669 Shaft)		2
23	6430-9	Outboard Mount, RH	1	F178	1/4 x 1 Fender Washer		2
24	5830	Grease Fitting	2	F194	7/16 x 1-1/4 x 1/8 Washer		2
25	6840-1	Support Arm Bushing (2-1/16)	2	F200	7/16-20 x 3 Grade 8 Bolt		2
				F244	7/16-20 x 3/4 Hex Bolt		2
				F262	3/8-16 x 4 Hex Bolt All Thread		1
				F359	5/16-18 x 5/16 Set Screw (Unbrako Knurl Point)		4
				F416	3/8-16 x 4 Socket Head Cap Screw		1
				* Service Part Only			
				** Part not used on Jackshaft side of tractor.			

# HYDROSTATIC GROUND DRIVE ASSEMBLIES

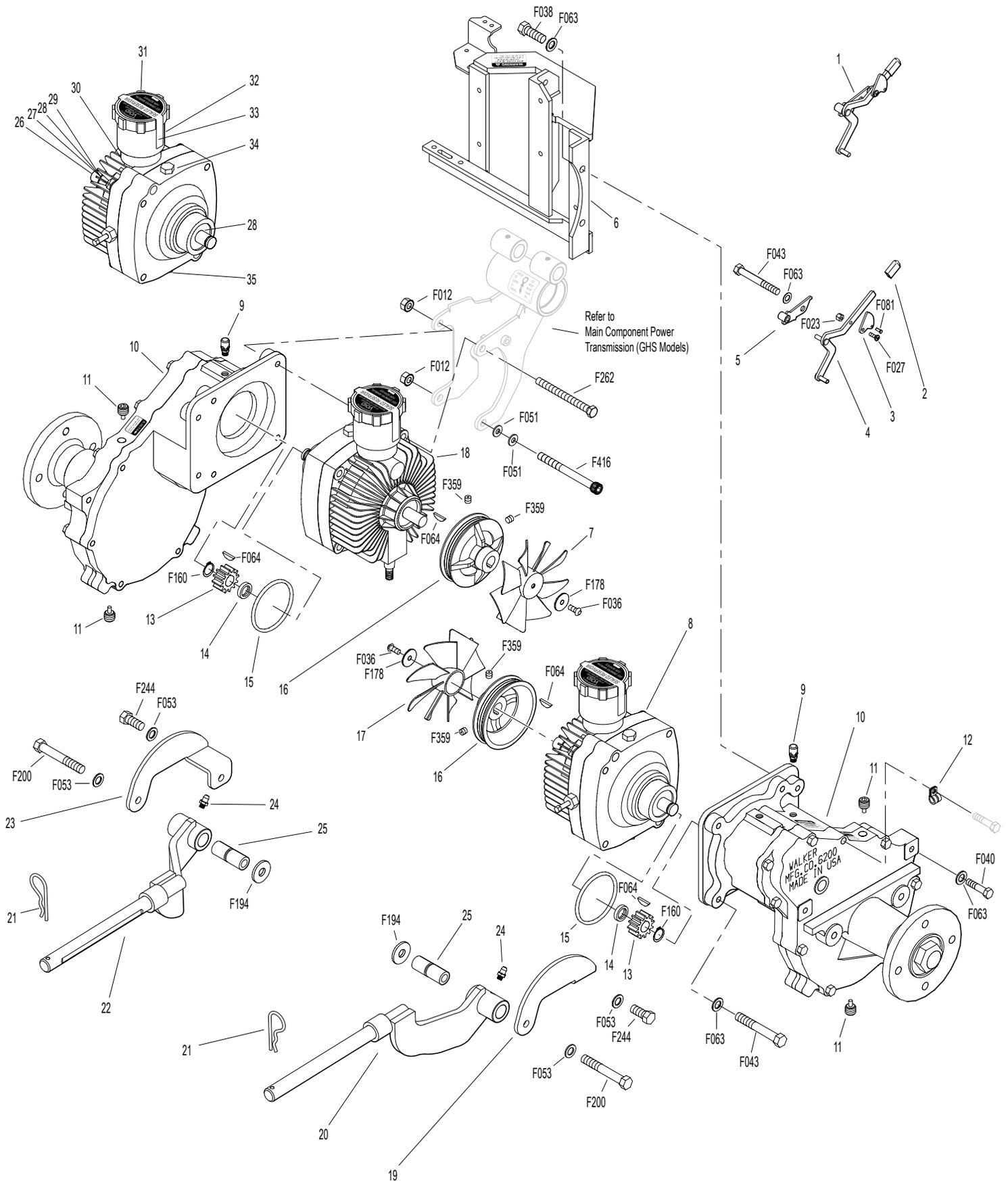

Beginning S/N 125598  
 Effective Date 11-18-13  
 Use only genuine **Walker**® replacement parts.

# STEERING CONTROL ASSEMBLIES

ITEM NO.	PART NO.	DESCRIPTION	NO. REQ'D	ITEM NO.	PART NO.	DESCRIPTION	NO. REQ'D
<b>Transmission Spring Assemblies</b>				30	5470-1	Speed Control Stop	1
1	6201-2	Shock Mount Gear Drive, RH	1	31	5450-10	Steering Lever Assembly, RH / Adjustable (Includes Items # 9, 10, 16, F360 & F489)	1
2	5146	10mm Ball Stud	4		5450-7	Steering Lever Arm, RH / Adjustable	*
3	5199-3	Steering Lever Dampener Assembly	2	32	5862	FSC Knob	1
4	6201-1	Shock Mount Gear Drive, LH	1	33	7170	FSC Lever Assembly (Includes Item # 16)	1
5	5214-2	Ball Joint (5/16-24) Nylon Lined	2	34	5975-3	Cable Tie (50# x 7")	1
6	6212-1	Transmission Control Arm, LH	1	<b>Fasteners</b>			
7	5213-3	Control Rod (6")	1		F003	1/4-28 Hex Nut	1
8	5665-1	Compression Spring (2-1/2)	2		F004	1/4-20 Keps Nut	6
9	5463-2	Steering Lever Actuator	2		F007	5/16-18 Jam Nut	1
10	7201-2	Fiberglide Bearing 1/2"	2		F008	5/16-24 Keps Nut	2
11	5213-4	Control Rod (14-3/4")	1		F009	5/16-18 Whiz Locknut	5
12	5212	Transmission Control Arm, RH	1		F010	5/16-24 ESNA Nut	2
<b>Steering Lever &amp; FSC Assemblies</b>					F024	5/16-24 Jam Nut	2
13	5173	FSC Actuator Rod	1		F029	1/4-20 x 1/2 Hex Bolt	2
14	5172	Bearing, Delrin (.255 ID x .379 OD x .250)	1		F032	1/4-20 x 3/4 Hex Bolt	4
15	5142-2	FSC Actuator Cam	1		F034	5/16-18 x 3/4 Hex Bolt	1
16	5830	Grease Fitting	6		F050	1/4 SAE Washer	3
17	5141	FSC Friction Washer (1-1/2 x 3/8 x 1/16)	2		F051	3/8 SAE Washer	2
18	5140-15	FSC Friction Body (Includes Item # 16)	1		F064	1/8 x 1/2 Woodruff Key (#3)	2
19	5142-7	FSC Key W/Stop	1		F068	1/8 x 1 Cotter Pin	1
	5140-13	FSC Control Assembly (Includes Items # 15-19, F192 & F193)	*		F069	3/32 x 1/2 Cotter Pin	1
20	5850-2	Handle Grip, Foam (5-1/2)	2		F093	5/16-18 x 1 Hex Bolt	1
21	5223	Extension Spring (1/4 x 5-1/2)	2		F183	.312 x .700 x .074 Washer	2
22	5450	D-Clip	2		F186	5/64 x 1/2 Cotter Pin	1
23	5391-3	Steering Lever Support	1		F188	1/4-20 Self-Locking Nut	4
24	5217	Pivot Pin, Steering Lever	1		F192	3/8-24 Self-Locking Nut	1
25	5451-10	Steering Lever Assembly, LH / Adjustable (Includes Items # 9, 10, 16, F360 & F489)	1		F193	3/8 Belleville Spring Washer	3
	5451-7	Steering Lever Arm, LH / Adjustable	*		F198	.250 x .625 x .040 Washer, SS	2
26	5453-10	Steering Lever Handle, Adjustable (Includes Items # 20 & F345)	2		F345	1/4-20 x .770 Knurled Bolt	4
27	5219	Extension Spring (3/4 x 6-3/4)	1		F353	3/8-16 ESNA LP Nut	2
28	5280	Clevis (1/4")	1		F360	1/4-20 x 3/8 Hex Bolt	2
29	5281-5	Clevis Pin (1/4 x 0.80)	1		F401	.504 x .751 x .030 Washer	1
					F489	Washer 1/4 x 7/8 x .090	2
				*	Service Part Only		



# THROTTLE CONTROL ASSEMBLY

ITEM NO.	PART NO.	DESCRIPTION	NO. REQ'D	ITEM NO.	PART NO.	DESCRIPTION	NO. REQ'D
<b>Throttle &amp; Choke Control Assemblies</b>				<b>Fasteners</b>			
1	8121-1	Throttle Cable	1		F002	10-24 Keps Nut	2
2	5172	Bearing, Delrin (.255 x .379 x .250)	1		F005	1/4-20 ESNA Nut	1
3	5108-7	Control Lock Tab	1		F025	10-24 x 3/8 PPHMS	2
4	5108-10	Friction Washer (.125)	1		F050	1/4 SAE Washer	1
5	5108-1	Control Lever, Throttle & Choke	1		F164	10-24 x 1/4 x 3/8 SHL Bolt	1
6	5108-5	Throttle Control Knob, Red	1		F201	1/4 Belleville Spring Washer	2
7	5108-11	Friction Washer (.062)	1				
8	5108-8	Control Bracket	1	*		Service Part Only	
9	7108	Control Assembly (Includes Items # 3-5, 7, 8 & F201)	1				
	8121	Throttle Control and Cable Assembly (Includes Item # 6)	*				
10	8123	Insulation Sleeve (3/8 x 6)	1				
11	5975-1	Cable Tie (18# x 3-3/4")	1				

# THROTTLE CONTROL ASSEMBLY

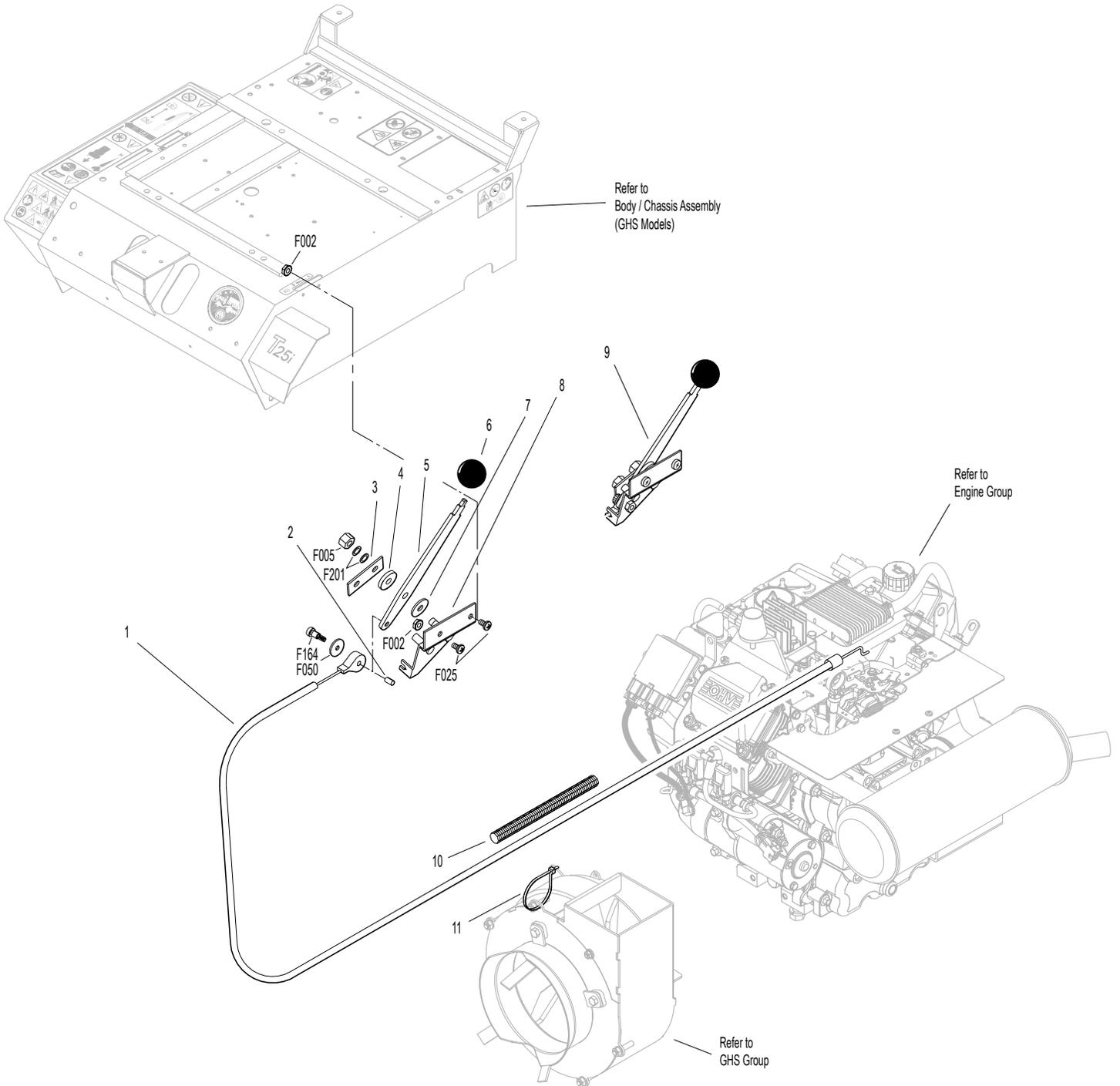

Beginning S/N 125598  
Effective Date 11-18-13  
Use only genuine **Walker**® replacement parts.

# PARKING BRAKE ASSEMBLY

ITEM NO.	PART NO.	DESCRIPTION	NO. REQ'D	ITEM NO.	PART NO.	DESCRIPTION	NO. REQ'D
<b>Parking Brake Assembly</b>				<b>Fasteners</b>			
1	7406-1	Handle Grip, Red	1	F002		10-24 Keps Nut	2
2	7406-8	Parking Brake Lever (4-1/4)	1	F003		1/4-28 Hex Nut	1
3	7406-2	Lever Mount	1	F004		1/4-20 Keps Nut	4
4	5830	Grease Fitting	1	F025		10-24 x 3/8 PPHMS	2
5	7407	Clevis Pin (3/16 x 1/2)	2	F029		1/4-20 x 1/2 Hex Bolt	3
6	7404	Brake Actuator Arm	2	F032		1/4-20 x 3/4 Hex Bolt	1
7	7405	Pin, Transmission Lock	2	F054		AN960616 Washer	2
8	7402	Clevis	2	F072		1/4 "E" Retainer Ring	2
9	7408	Compression Spring (1/2 x 3/4)	2	F086		#10 SAE Washer	4
10	7415	Rubber Dust Shield (5/8 x 3/8 x 1/32)	2	F109		1/8 x 5/8 Roll Pin	2
11	5567-3	O-Ring Seal (1/4 x 3/8)	4	F111		1/8 x 3/4 Cotter Pin	1
12	7403	Plunger Bushing, Gear Axle	2	F112		5/8 x 1-1/4 x .03 Washer	2
13	7404-1	Brake Actuator Mount	2	F127		1/16 x 1/2 Cotter Pin	4
14	7412	Clevis Pin (3/16 x 5/8)	2	F261		AN960616L Washer	5
15	5833	Cable Clamp (1/4)	2	F287		1/4-28 Keps Nut	1
16	7410	Brake Control Cable, LH (25.5")	1				
17	7409	Brake Control Cable, RH (20.5")	1				
18	7401-3	Cable Mount Bracket	1				
19	7401-1	Cable Pull Rod	1				
20	5552	Ball Joint (1/4-28)	1				

# PARKING BRAKE ASSEMBLY

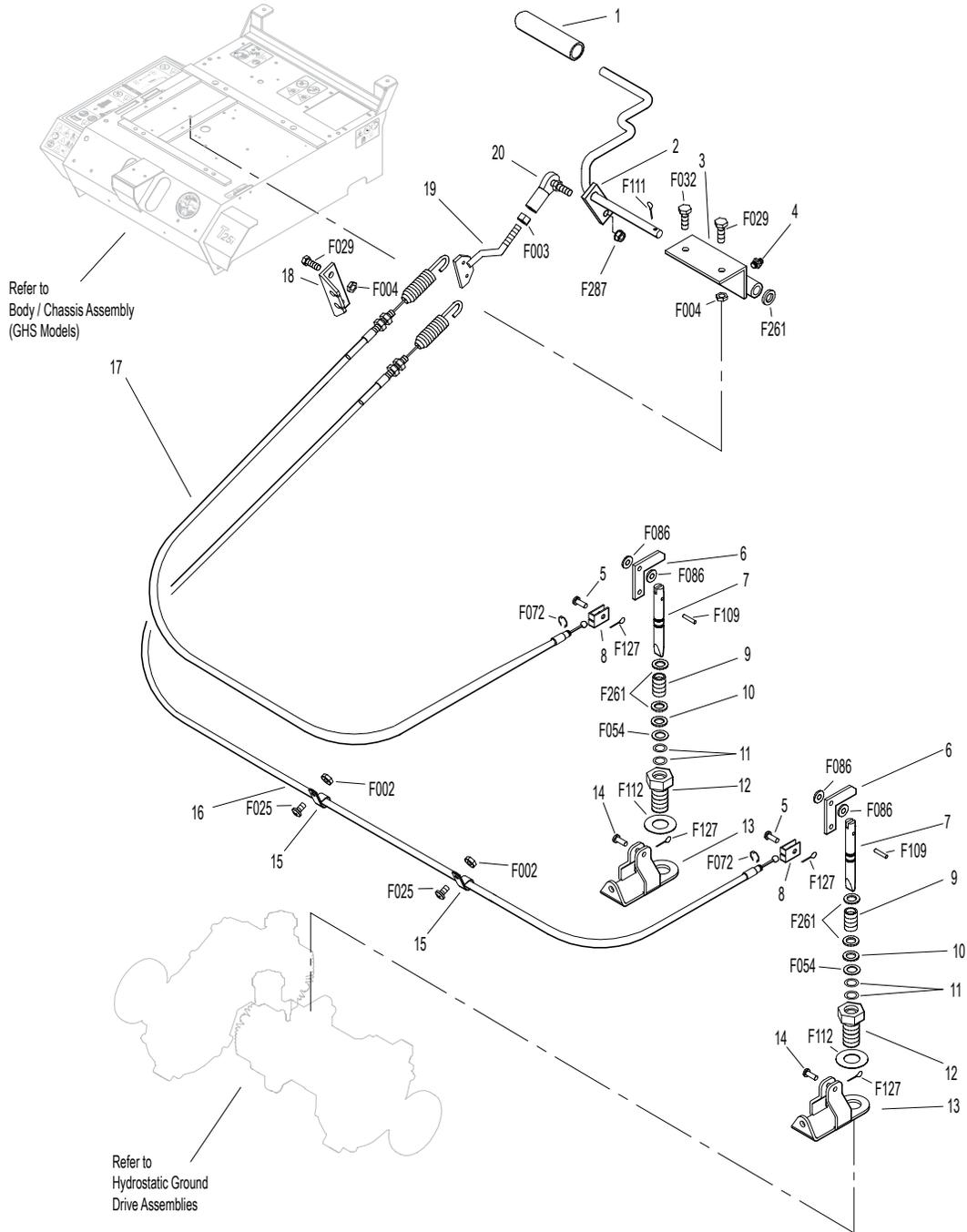

# GHS GROUP

ITEM NO.	PART NO.	DESCRIPTION	NO. REQ'D	ITEM NO.	PART NO.	DESCRIPTION	NO. REQ'D
<b>Delivery Chute Assembly</b>				<b>Fasteners</b>			
1	5515-4	Elbow Delivery Spout	1	F002		10-24 Keps Nut	6
2	5592-13	Backing Plate, Grass-Pak® Switch	1	F004		1/4-20 Keps Nut	3
3	5578	Rear Clip, Chute Mount	1	F009		5/16-18 Whiz Locknut	7
4	5577	Side Clip, Chute Mount	2	F012		3/8-16 Keps Nut	3
5	8511-1	Delivery Chute W/Clips (Includes Items # 3, 4, 6, F362 & F411)	1	F026		10-24 x 1/2 PPHMS	2
6	5578-10	Front Clip, Chute Mount	1	F029		1/4-20 x 1/2 Hex Bolt	3
7	7530-4	Body Chute (10.5 Blower)	1	F034		5/16-18 x 3/4 Hex Bolt	1
<b>Blower Belt Tightener Assembly</b>				F039		3/8-16 x 1-1/4 Hex Bolt	1
8	7238-6	Blower Drive Pulley (Includes Items # F075, F114 & F231)	1	F040		3/8-16 x 1-1/2 Hex Bolt	1
9	7234-2	Blower Belt (Micro-V)	1	F042		3/8-16 x 2-1/4 Hex Bolt	1
10	7239-1	Blower Pulley (Mirco-V) (Includes Items # F067, F075 & F114)	1	F050		1/4 SAE Washer	1
11	7364-2	Torsion Spring	1	F054		AN960616 Washer	1
12	7201-3	Fiberglide Bearing	2	F067		3/16 x 3/16 x 1 Key	1
13	5830-3	Grease Fitting (45 Deg.)	1	F075		5/16-18 x 1/2 SQH Set Screw	2
14	7364-1	Blower Belt Tightener Arm	1	F079		A/A66D Aluminum Pop Rivet	6
15	7201-4	Inner Race (1-1/2)	1	F090		1/4-20 x 2-1/2 Hex Bolt	1
16	5841	Retainer Washer (3/8 x 1-1/4)	1	F114		5/16-18 x 5/8 SQH Set Screw	2
17	5245	Idler Pulley (3")	1	F128		10-24 x 3/8 PTHMS	4
<b>Blower Assembly</b>				F131		5/16-18 x 1/2 Hex Bolt	3
18	7544	Blower Assembly (10.5") (Includes Items # 19-24, F004, F009, F029, F050, F131, F168 & F426)	1	F132		1/4-20 x 2-3/4 Hex Bolt	1
19	5268	Bearing W/Collar (3/4)	2	F168		5/16 Split Lock Washer	3
20	7544-3	Blower Housing (10.5)	1	F217		7/16-14 Hex Nut	1
21	7545-2	Blower Output Shaft (10.5)	1	F218		7/16 Split Lock Washer	1
22	7545	Blower Wheel (10.5")	1	F231		1/4 x 3/4 Woodruff Key (# 806)	1
23	7543-1	Blower Faceplate (10.5)	1	F281		7/16-14 x 1-3/4 Hex Bolt	1
24	7526	Intake Tube (10.5 Blower)	1	F362		A/A62D Alum. Pop Rivet (3/16D x 13/32L)	2
25	5595-2	Intake Cover / GHS	*	F411		3/16 Bulbex Rivet	6
26	7528-2	Skid Bar (10.5" Blower)	1	F426		1/4-20 x 1/2 Carriage Bolt	1

# GHS GROUP

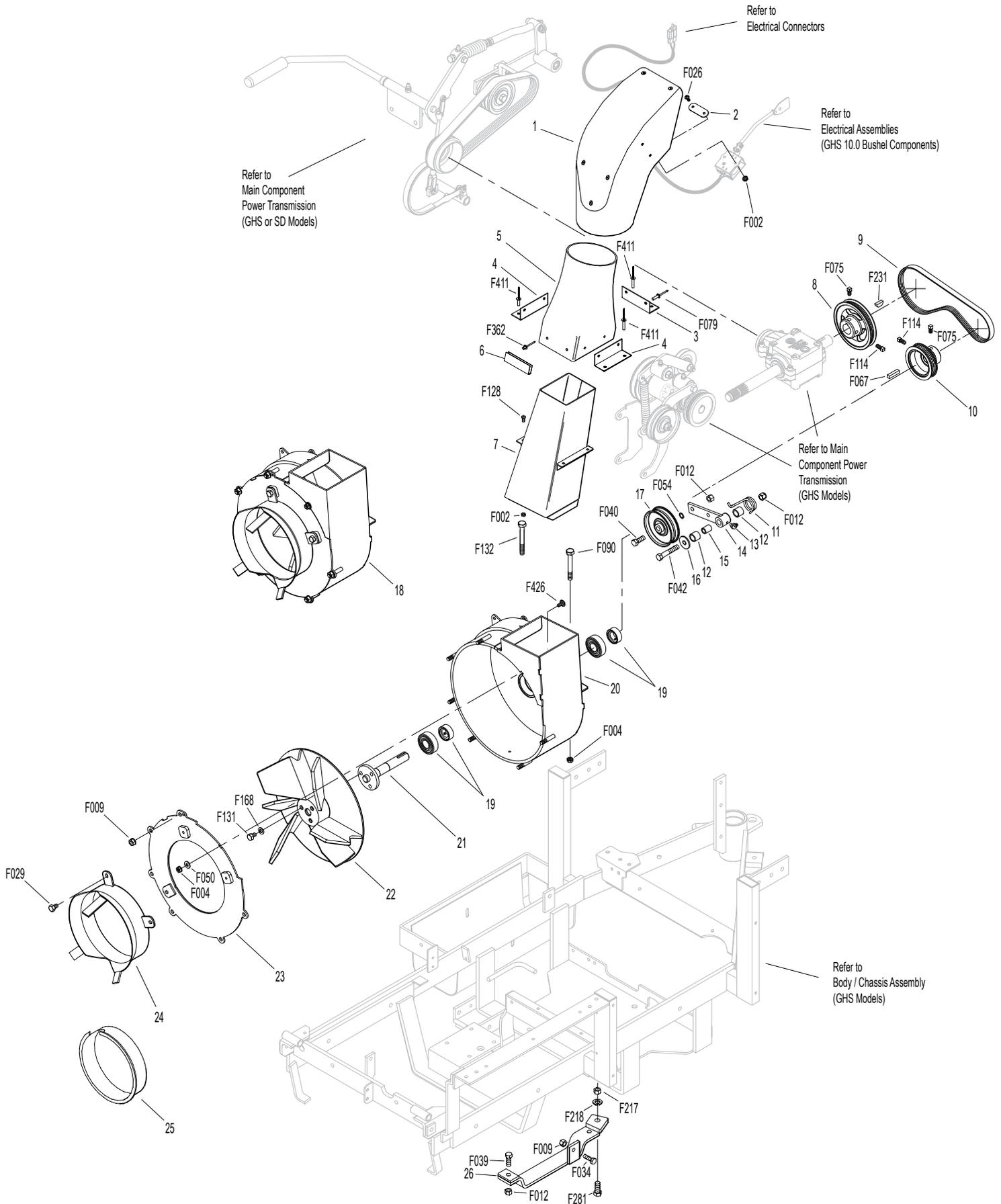

Beginning S/N 125598  
 Effective Date 11-18-13  
 Use only genuine **Walker®** replacement parts.

# GHS POWERFIL® ASSEMBLY

ITEM NO.	PART NO.	DESCRIPTION	NO. REQ'D	ITEM NO.	PART NO.	DESCRIPTION	NO. REQ'D
<b>10.0 GHS Powerfil® Assembly</b>				<b>Fasteners</b>			
1	5551-3	Bearing Cap, Powerfil®	1		F002	10-24 Keps Nut	10
2	5551-1	Pivot Bearing (#S3PP)	2		F003	1/4-28 Hex Nut	3
3	5518-2	Pivot, Delivery Spout	1		F026	10-24 x 1/2 PPHMS	1
4	5517-2	Pivot Mount	1		F037	10-24 x 5/8 PTH Screw	2
5	5552	Ball Joint (1/4-28)	2		F054	AN960616 Washer	1
6	5558-1	Powerfil® Push Rod	1		F085	3/16 Rivet Backup Washer	1
7	5553-3	Bushing, Powerfil® Actuator	4		F101	10-24 x 1-1/4 SHC Screw	1
8	5553-1	Compression Spring (1/2 x 2)	2		F109	1/8 x 5/8 Roll Pin	1
9	5558-2	Powerfil® Actuator Rod	1		F129	10-24 x 1/2 PTHMS	6
	5549	Actuator Rod Assembly (Includes Items # 5-9 & F003)	*		F261	AN960616L Washer	1
10	5554	Actuator Arm	1		F287	1/4-28 Keps Nut	1
11	5519-3	Motor Mount Nut (5/8-24)	*	*	Service Part Only		
12	5519-2	Motor Mount Washer	*				
13	5976-2	Grommet (3/16 x 3/4)	1				
14	5519-5	Actuator Motor (12V) (Includes Items # 11 & 12)	1				

# GHS POWERFIL® ASSEMBLY

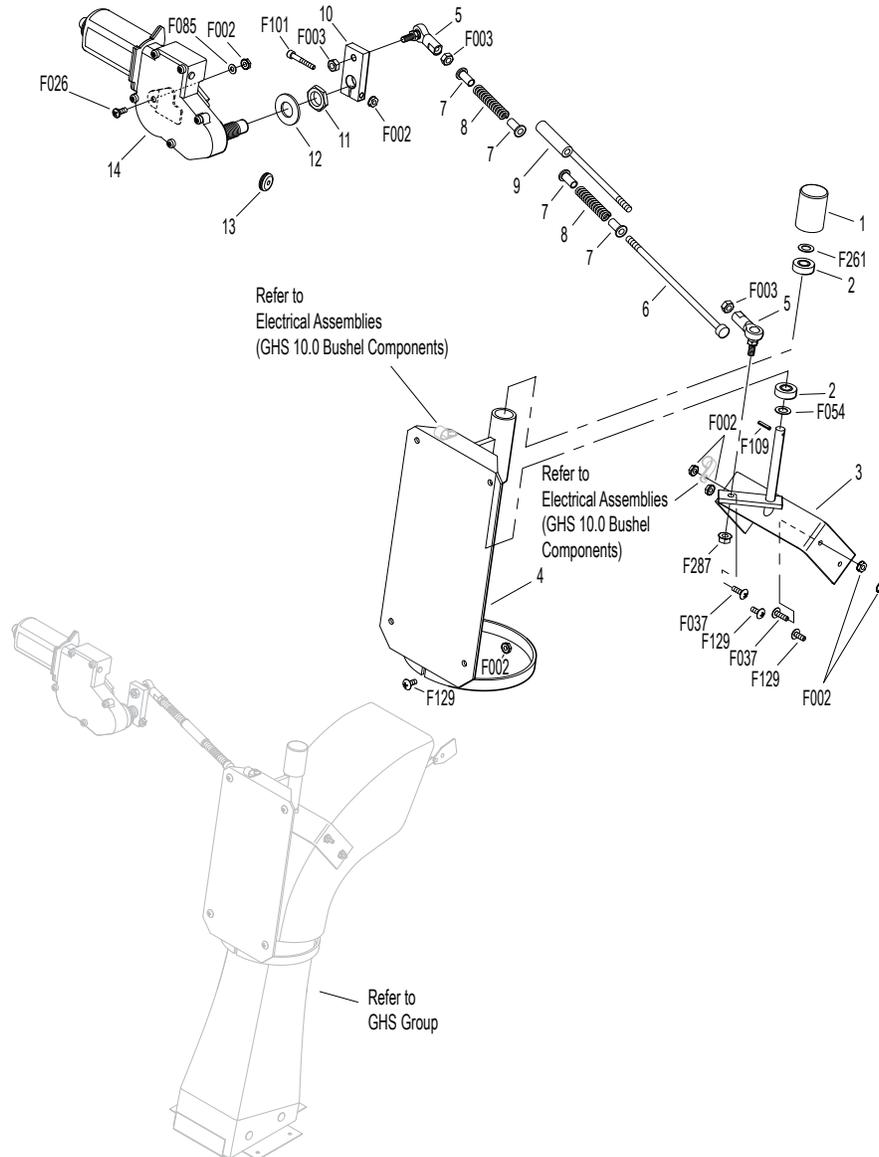

Beginning S/N 125598  
Effective Date 11-18-13  
Use only genuine **Walker**® replacement parts.

# GHS 10.0 BUSHEL CATCHER ASSEMBLY

ITEM NO.	PART NO.	DESCRIPTION	NO. REQ'D	ITEM NO.	PART NO.	DESCRIPTION	NO. REQ'D
<b>Upper Baffle Screen Assembly (Removable)</b>				45	8608-10	Box Support, Gas Spring	2
1	7512-2	Removable Screen (3/16 Hole) (Includes Items # 2, 5, F025 & F190)	1**	46	7532-1	Handle, Catcher Lift	2
2	7506	Knob / Threaded Insert (10-24)	2	47	5977	Grommet (1/2 x 7/8 x 1/16)	2
3	8606-3	Channel Top, LH	1	48	8117	Wire Harness Channel	1
4	8606-2	Channel Bottom	2	49	8602-3	10.0 Catcher W/O Powerfil®, Gray (Includes Door)	*
5	7856-1	Edge Molding (26")	1		8602-4	10.0 Catcher W/Powerfil®, Gray (Includes Door)	*
6	7507	Screen Seal (27-1/2)	1		8610-5	10.0 Bushel Catcher Box, Gray	*
7	7505	Mustache Spring	2	50	8607-9	Powerfil® Cover Plate	1
8	8606	C-Channel (10.0)	1	51	8155-2	Gas Spring Cover, RH	1
	8606-20	C-Channel With Spring (10.0) (Includes Items # 7, 8 & F340)	*	52	8608-8	Hinge Plate, RH	1
9	8606-4	Channel Top, RH	1	53	8608-9	Torsion Bar	1
<b>10.0 Exhaust Deflector Door Assembly</b>				<b>5598-2 Optional Dump Bag (Not Shown)</b>			
10	8607-6	Upper Seal Support	1	May be ordered as an option. Contact your Walker dealer.			
11	8607-5	Upper Door Seal	1	<b>Fasteners</b>			
12	8607-11	Backup Plate	1	F002	10-24 Keps Nut		29
13	8512-3	10.0 Catcher Box Door (Includes Items # 10-14, 16, 17, F085, F330 & F411)	1	F004	1/4-20 Keps Nut		25
14	5583	Handle	1	F009	5/16-18 Whiz Locknut		4
15	8607-1	Door Mount, LH	1	F020	5/16-18 ESNA Nut		2
16	8607-12	Upper Door Stiffener	1	F024	5/16-24 Jam Nut		4
17	8607-7	Lower Door Stiffener	1	F025	10-24 x 3/8 PPHMS		4
18	8607-8	Door Guide	1	F026	10-24 x 1/2 PPHMS		2
19	8607-2	Door Mount, RH	1	F027	10-24 x 5/8 PPHMS		8
<b>GHS 10.0 Bushel Catcher Assembly</b>				F029	1/4-20 x 1/2 Hex Bolt		10
20	8608-5	Center Strap	1	F049	5/16 SAE Washer		8
21	8608-3	Upper Frame Doubler	2	F050	1/4 SAE Washer		2
22	8608-1	Outside Box Strap, LH	2	F068	1/8 x 1 Cotter Pin		2
23	8608-2	Lower Frame Doubler	2	F079	A/A66D Aluminum Pop Rivet		14
24	8608-4	Center Frame Doubler	1	F085	3/16 Rivet Backup Washer		13
25	8608-11	Catcher Door Finger	1	F094	8-32 x 1/2 PTHMS		6
26	8608-6	Catcher Mount	1	F129	10-24 x 1/2 PTHMS		18
27	8610-4	Catcher Dump Flap W/Plate 10.0	1	F190	#10 Internal Star Lock Washer		2
28	8610-3	Backing Plate, Dump Flap	1	F195	1/4-20 x 3/4 PPHMS, SS		4
29	7584	Reinforcing Strap	1	F196	1/4-20 x 1 PPHMS, SS		4
30	5103-5	Pivot Bushing Inner	2	F208	5/16-18 x 2-1/4 Hex Bolt		2
31	5801-3	Decal Plate, Round (Set of 2)	1	F230	1/4-20 x 1-1/4 PPHMS, SS		4
32	7620-3	Pivot Bushing (1/2 x 9/16)	2	F242	1/4-20 x 7/8 PPHMS, SS		8
33	8608-7	Hinge Plate, LH	1	F330	3/16D x 21/32L Rivet, SS		9
34	5103-7	Outside Torsion Bushing	2	F340	Rivet, Aluminum		4
35	8607-4	Upper Arm	2	F351	Aluminum Pop Rivet		6
36	5214-12	Ball Joint (5/16-24)	4	F360	1/4-20 x 3/8 Hex Bolt		2
37	5155-12	5/16 Ball Stud	2	F390	1/4-20 x 7/8 Carriage Bolt		4
38	5155-4	Gas Spring	2	F411	3/16 Bulbex Rivet		10
39	5147	Spring Clip	4	F456	5/16-18 x 3/4 SBH Cap Screw, SS		4
40	8155-1	Gas Spring Cover, LH	1	F503	1/4-20 x 1-1/2 PPHMS, SS		1
41	8607-3	Lower Arm	2	F524	3/16 x 3/8 Aluminum Rivet, Black		6
42	5103-6	Pivot Bushing Outer	2	* Service Part Only			
43	5155-13	3/4 Ball Stud	2	** This screen can be replaced by P/N 7512-3 Removable Screen (3/4" holes) for improved air flow performance in wet conditions.			
44	5523-6	Gas Spring Plate	2				

Beginning S/N 125598

Effective Date 11-18-13

Use only genuine Walker® replacement parts.



# INSTRUMENT PANEL ASSEMBLY

ITEM NO.	PART NO.	DESCRIPTION	NO. REQ'D	ITEM NO.	PART NO.	DESCRIPTION	NO. REQ'D
<b>Instrument Panel Assembly</b>				21	8996-10	Amber Indicator Light Assembly (Includes Items # 16 & 20)	1
1	7307-2	Instrument Panel Cover (Optional)	**	22	7307-1	Shock Mount (1.0 x .25)	3
	8306-5	Instrument Panel Assembly (Includes Items # 2-12, 14, 19, 21, 29, F228, F250, F251, F349 & F448)	1	23	7391	Panel Box Mount Plate	2
2	7307-7	Panel Frame	1	24	8385	Panel Box W/Graphic	1
3	8820-4	Panel Faceplate	1	25	7977-1	Grommet (1/8 x 1-1/16)	1
4	7386	Panel Gasket	1	26	7307-16	Lining, Panel Box (1/8)	1
5	8996-2	Red Indicator Light Assembly	2	27	6941-6	Relay Switch (30/40 Amp)	*
6	6942	Relay Switch (30/40 Amp) NC (Includes Items # 27 & 28)	2	28	6941-7	Relay Mount	*
7	7941-3	Boot, Circuit Breaker	1	29	8536	Warning Horn	1
8	7941-5	Circuit Breaker (7 Amp)	1	<b>Fasteners</b>			
9	8997	Voltmeter Gauge	1	F004	1/4-20 Keps Nut		6
10	5995-2	Switch Boot	1	F228	#6 x 5/8 PPHSMS, SS		8
11	5995	Toggle Switch (Off-On)	1	F238	J Clip, Instrument Panel		8
12	8990-1	Hourmeter (Global)	1	F250	6-32 x 1/2 PPHMS		1
13	5975-1	Cable Tie (18# x 3-3/4")	2	F251	6-32 Keps Nut		2
14	8945-3	Wire Harness, Instrument Panel	1	F349	Washer .835 ID, 1.122 OD, SS		1
15	8996-4	Red Indicator Lens	2	F448	6-32 x 5/16 PPHMS		1
16	8996-3	Indicator Bulb (Replacement for P/N 8996-2)	*	* Service Part Only			
17	8960-3	Key Set W/Umbrella	*	** May be ordered as an option. Contact your Walker dealer.			
18	7854	Plastic Tip, Red	1	<b>NOTE:</b> Refer to <b>ELECTRICAL CONNECTORS</b> , Page 38 for identification of all Electrical Wiring Service Parts.			
19	8960-15	Ignition Switch (with Keys) (Includes Items # 17, 18 & F349)	1				
20	8996-6	Amber Indicator Lens	1				

# INSTRUMENT PANEL ASSEMBLY

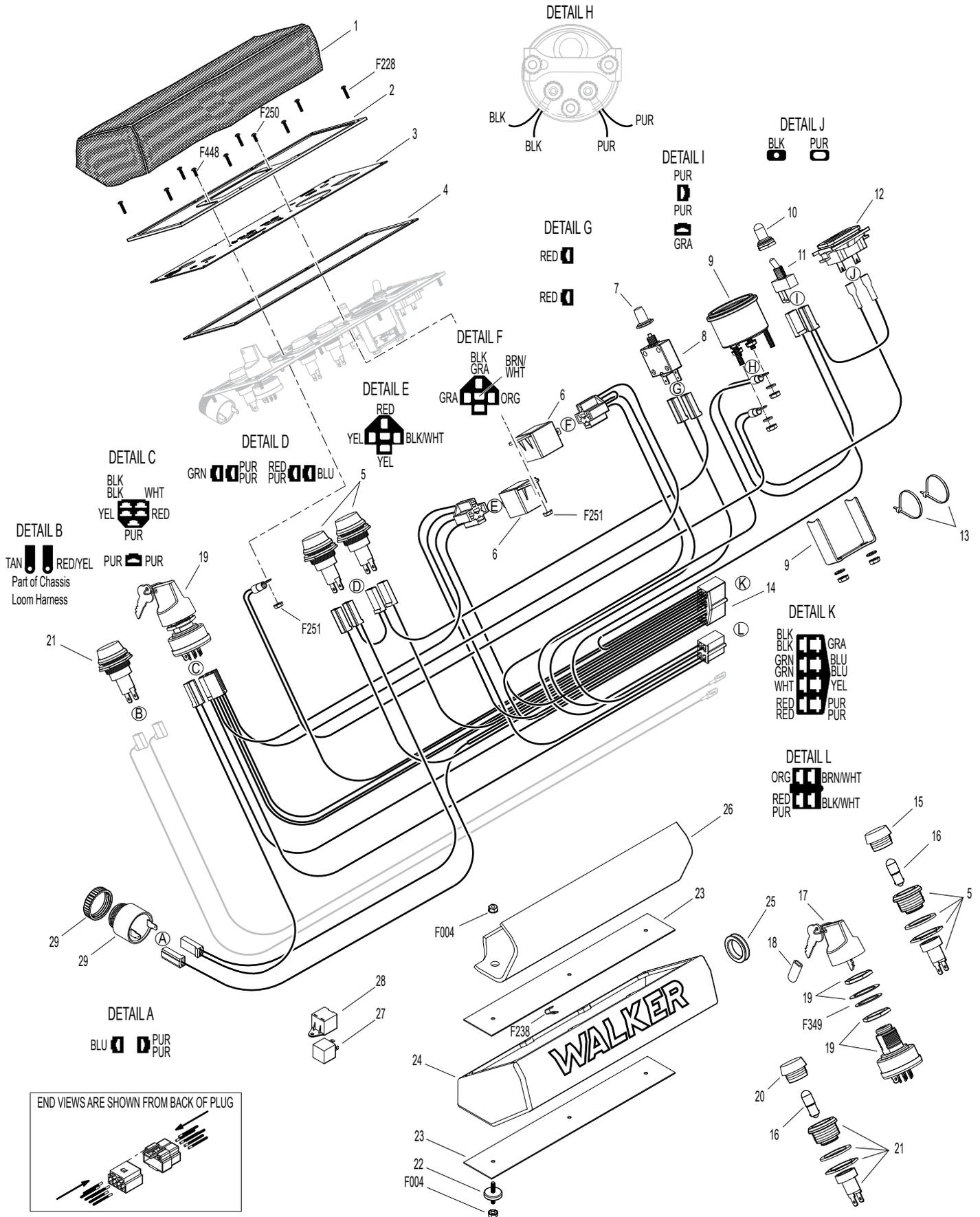

Beginning S/N 125598  
 Effective Date 11-18-13  
 Use only genuine **Walker**® replacement parts.

# ELECTRICAL ASSEMBLY

ITEM NO.	PART NO.	DESCRIPTION	NO. REQ'D	ITEM NO.	PART NO.	DESCRIPTION	NO. REQ'D
<b>Harness Assembly</b>				<b>Fasteners</b>			
1	5975-3	Cable Tie (50# x 7")	6	F002		10-24 Keps Nut	10
2	5942-4	PTO Safety Switch (Normal Open)	1	F004		1/4-20 Keps Nut	4
3	5833	Cable Clamp (1/4)	1	F009		5/16-18 Whiz Locknut	1
4	8940-22	Wire Harness, EFI	1	F019		1/4-20 ESNA Wing Nut	2
5	7833	Cable Clamp (7/8 x 1/4)	2	F025		10-24 x 3/8 PPHMS	5
6	5832	Cable Clamp (1/2)	1	F026		10-24 x 1/2 PPHMS	3
7	8012-5	Regulator Adapter Harness	1	F031		1/4-20 x 5/8 Hex Bolt	2
8	NS	Rectifier	*	F032		1/4-20 x 3/4 Hex Bolt	2
9	8012-7	Ground Wire	1	F050		1/4 SAE Washer	4
10	7833-2	Cable Clamp (1 x 1/4)	2	F061		1/4 Star Lock Washer	1
11	6942	Relay Switch (30/40 Amp) NC (Includes Items # 21 & 22)	1	F063		3/8 Internal Star Lock Washer	1
12	7948-6	Time Delay Module	1	F079		A/A66D Aluminum Pop Rivet	2
13	7948-5	Time Delay Harness	1	F085		3/16 Rivet Backup Washer	1
14	8941	Circuit Breaker (30 Amp) Auto Reset / Sealed	1	F093		5/16-18 x 1 Hex Bolt	1
15	8943	Positive Battery Lead Wire (Red)	1	F106		3/8-16 x 5/8 Hex Bolt	1
16	5942-5	Safety Switch (Normal Open)	1	F124		10-32 x 3/8 Taptite Machine Screw	2
17	5975-1	Cable Tie (18# x 3-3/4")	3	F129		10-24 x 1/2 PTHMS	1
18	5941-5	Safety Switch (Normal Open)	1	F232		10-32 Keps Nut	2
19	7203-6	Riser Plate, Seat Switch	2				
20	5977-6	Grommet (1 x 1-1/4)	1				
21	6941-7	Relay Mount	*				
22	6941-6	Relay Switch (30/40 Amp)	*				
<b>Battery Assembly</b>				* Service Part Only			
23	6923	Negative Battery Cable	1	<b>NOTE:</b> Refer to <b>ELECTRICAL CONNECTORS</b> , Page 38 for identification of all Electrical Wiring Service Parts.			
24	5933	Battery Terminal Insul., Red (+)	1				
25	5844-3	Battery Hold-Down Bar	1				
26	5839	Hook Bolt	2				
27	7390-1	Battery Pan	1				
28	NS	Battery (12V/340CCA/Dry)	1				
29	5932	Battery Terminal Insul., Black (-)	1				
30	7834-2	Wire Saddle (2 Wires)	1				



# ELECTRICAL ASSEMBLIES (GHS 10.0 BUSHEL COMPONENTS)

ITEM NO.	PART NO.	DESCRIPTION	NO. REQ'D
----------	----------	-------------	-----------

## 10.0 Harness Components

1	5519-4	Adapter Harness	1
2	5975-1	Cable Tie (18# x 3-3/4")	1
3	7835	Frame Clip (3/16)	6
4	5975-3	Cable Tie (50# x 7")	1
5	5536-2	Horn, Full Signal	*
6	8950	9.5 / 10.0 Wire Harness	1
7	5977-2	Grommet, Cut (1/8 x 3/8)	1

## Grass-Pak® Switch Assemblies

8	5594-6	Aluminum Shaft & Vane Assembly	1
9	5592-14	Grass-Pak® Switch Assembly	1
10	5833	Cable Clamp (1/4)	2

ITEM NO.	PART NO.	DESCRIPTION	NO. REQ'D
----------	----------	-------------	-----------

## Fasteners

F002	10-24 Keps Nut	4
F025	10-24 x 3/8 PPHMS	1
F037	10-24 x 5/8 PTH Screw	1
F129	10-24 x 1/2 PTHMS	2
F508	4-40 Keps Nut, SS	2
F509	4-40 x 1/2 Hex Head, SS	2

\* Service Part Only

**NOTE:** Refer to **ELECTRICAL CONNECTORS**, Page 38 for identification of all Electrical Wiring Service Parts.

# ELECTRICAL ASSEMBLIES (GHS 10.0 BUSHEL COMPONENTS)

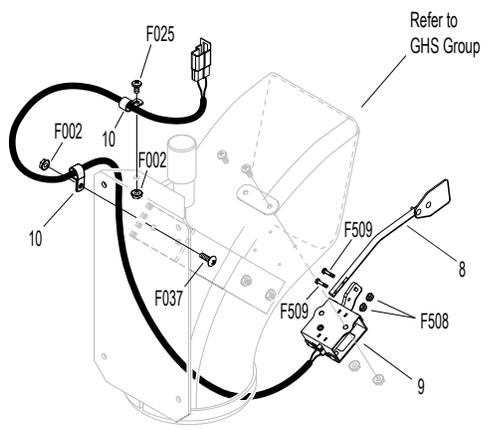
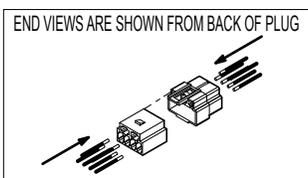
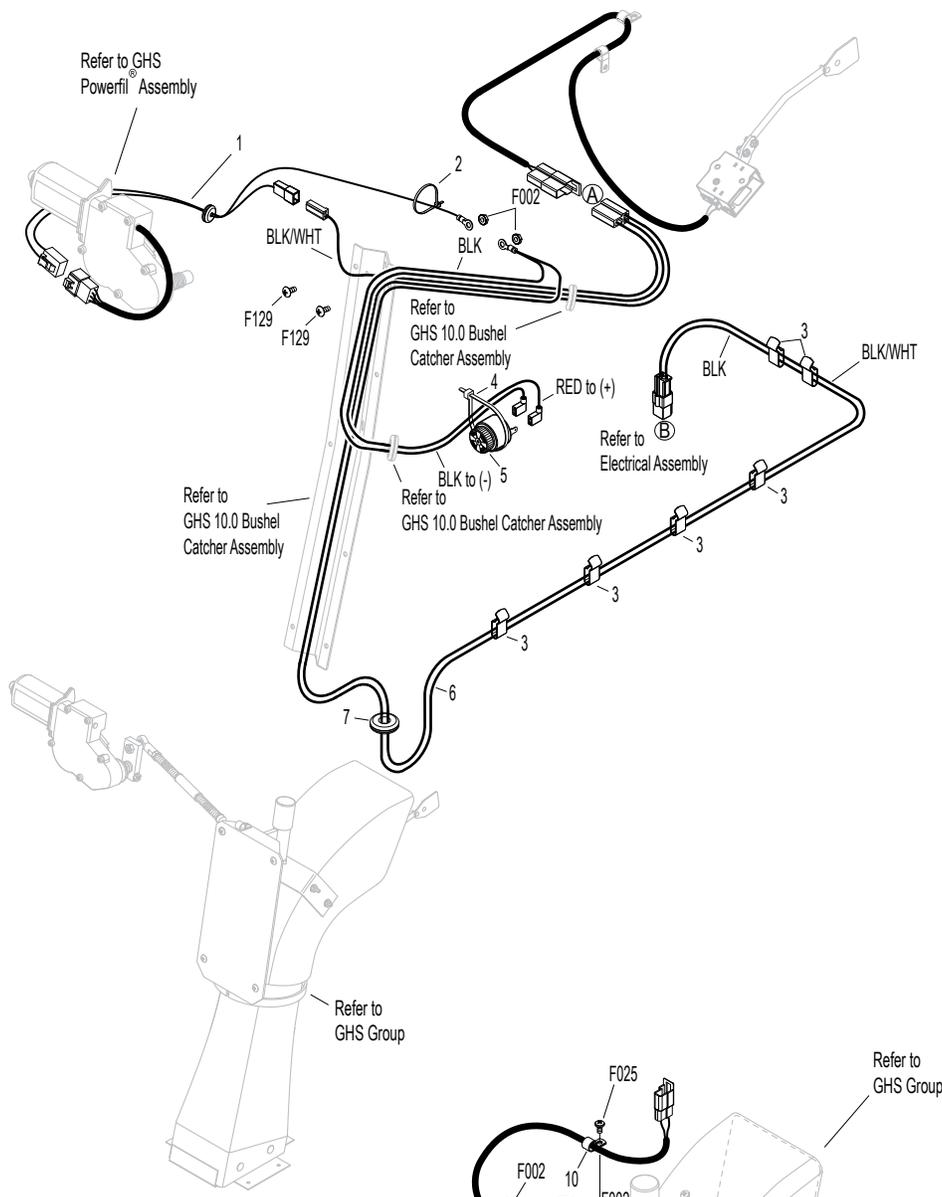

Beginning S/N 125598  
 Effective Date 11-18-13  
 Use only genuine **Walker**® replacement parts.

# ELECTRICAL CONNECTORS

ITEM NO.	PART NO.	DESCRIPTION	NO. REQ'D	ITEM NO.	PART NO.	DESCRIPTION	NO. REQ'D
<b>Electrical Wiring Service Parts</b>				29	7942-1	2-Way Locking Connector, Female	*
1	5996-1	16-14 GA Butt Connector	*	30	7942-2	2-Way Connector, Male	*
2	5996-11	12-10 GA Butt Connector	*	31	7942-3	2-Way Connector, Female	*
3	7942-14	16-14 GA Shrink Connector	*	32	7942-10	2-Way Locking Connector, Male	*
4	7942-13	12-10 GA Shrink Connector	*	33	5940-8	3-Way Connector, Male	*
5	5995-1	Wire Terminal Adapter	*	34	7942-9	3-Way Connector, Male	*
6	5996-4	16-14 GA Bullet Conn., Male	*	35	8944	3-Way Locking Connector, Male	*
7	5996-5	16-14 GA Bullet Conn., Female	*	36	8944-1	3-Way Locking Connector, Female	*
8	5940-4	16-14 GA Spg. Loaded Term., Female	*	37	7942-11	4-Way Connector, Male	*
9	5940-7	Wire Clip, Female	*	38	7942-12	4-Way Connector, Female	*
10	5996	1/4 x 16-14 GA QKS Term., Female	*	39	7942-5	5-Way Connector, Male	*
11	5996-2	3/16 x 22-18 GA QKS Term., Female	*	40	5940-2	5-Way Connector, Male	*
12	7996	16-14 GA QKS Term., Female	*	41	8942-1	5-Way Connector, Female	*
13	5940-5	16-14 GA Spg. Loaded Term., Male	*	42	7942-6	6-Way Connector, Male	*
14	5996-0	1/4 x 22-18 GA QKS Term., Male	*	43	7942-7	6-Way Connector, Male	*
15	5996-18	16-14 GA Ring Term. (#8) Nylon Insulated	*	44	7942-8	8-Way Connector, Male	*
16	7996-1	1/4 x 16-14 GA QKS Term., Male	*	45	8942-2	8-Way Connector, Female	*
17	5996-8	6 GA Ring Lug (5/16)	*	46	8942-3	5-Way Connector, Male	*
18	5996-9	22-18 GA Ring Term., #10	*	47	5940-9	3-Way Connector (M)	*
19	5996-10	16-14 GA Ring Term. (5/16)	*	48	7942-15	6-Way Connector (Female)	*
20	5996-12	12-10 GA Ring Term. (5/16)	*	49	7940-3	Packard Plug (Male)	*
21	5996-13	16-14 GA Ring Term., # 10	*	50	7940-4	Packard Plug (Female)	*
22	5996-15	12-10 GA Ring Term. (1/2)	*	* Service Part Only			
23	5996-16	6 GA Ring Terminal (1/4)	*	<b>NOTE:</b> Not all Electrical Connectors are used with all assemblies.			
24	5996-17	16-14 GA Ring Term. (1/4)	*	<b>NOTE:</b> Refer to <b>ELECTRICAL ASSEMBLY</b> , Page 34 for locations of Wiring Harness and of all Electrical Wiring Service Parts.			
25	5996-20	12-10 GA Ring Term. (1/4)	*				
26	5996-21	12-10 GA Ring Term., #10	*				
27	7942-4	Single Connector, Male	*				
28	8942	2-Way Connector, Male	*				

# ELECTRICAL CONNECTORS

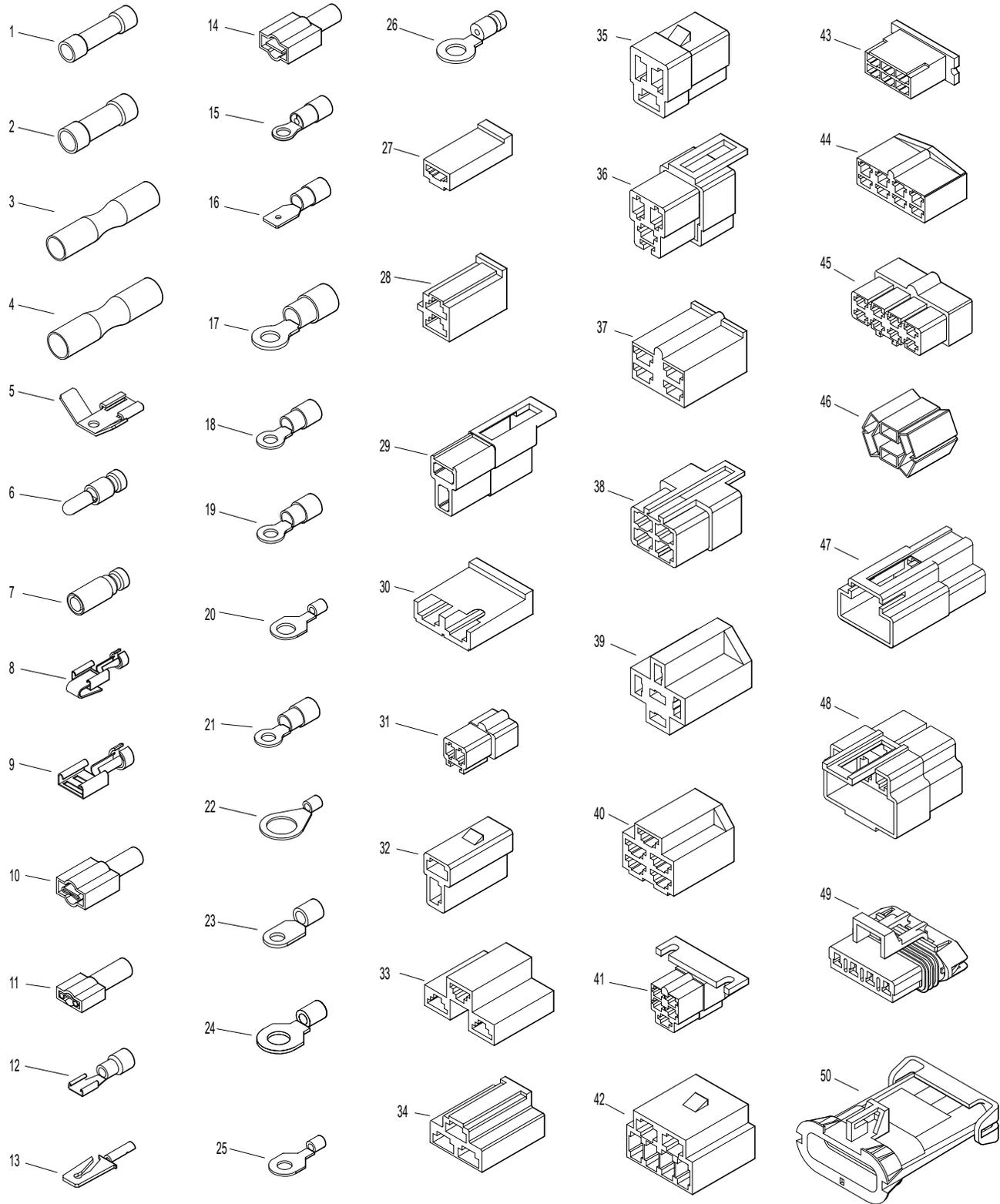

Beginning S/N 125598  
Effective Date 11-18-13  
Use only genuine **Walker**® replacement parts.

# LUBRICATION POINTS

ITEM NO.	LOCATION	LUBRICATION TYPE	NO. PLACES	ITEM NO.	LOCATION	LUBRICATION TYPE	NO. PLACES
<b>Lubrication Points</b>				19	Throttle Control Cable Ends	Oil	2
1	Steering Lever Pivot	Grease	4	20	Catcher Hinge Point	Oil	2
2	Body Hinge Point	Oil	2	21	Rear Wheel Bearings	Grease	2
3	Deck-to-PTO Coupling (Grease Spline Slide Area)	Grease	1	22	Engine Oil	Oil**	1
4	FSC Actuator Rod Pivot Pins	Oil	2	23	Belt Tightener Pivot, Blower Drive (GHS Model Only)	Grease	1
5	(FSC) Friction Body Pivot	Grease	1	24	Belt Tightener Pivot, Ground Drive	Grease	1
6	FSC Lever Pivot	Grease	1	25	PTO Gearbox Dipstick	Oil**	1
7	FSC Lever Fork (Grease Slide Area)	Grease	1	26	Hydrostatic Drive	Oil**	2
8	Deck Support Arm Pivot	Grease	2	27	Throttle Control Pivot	Oil	1
9	Universal Joint Tube Assembly	Grease*	1	* Grease every eight (8) hours.			
10	Parking Brake Lever	Grease	1	** Refer to MT <b>Operator's Manual</b> for procedure for checking and changing oil in Engine Crankcase, Hydrostatic Transmissions and Gear Axles.			
11	Universal Joint Quick Connect Spline (Grease Slide Area)	Grease	1	<b>NOTE:</b> See Model MT <b>Operator's Manual</b> (P/N 8000-17) for proper lubrication intervals.			
12	Gear Axle	Oil**	2				
13	Belt Tightener Pivot, Jackshaft Drive	Grease	1				
14	PTO Clutch Lever Pivot	Grease	1				
15	Clutch Actuator Push Rod	Grease	2				
16	Belt Tightener Pivot, PTO Clutch	Grease	1				
17	Brake Actuator Rod and Brake Band Pivot Pins (Clevis)	Oil	3				
18	Brake Actuator Pivot	Grease	1				

# LUBRICATION POINTS

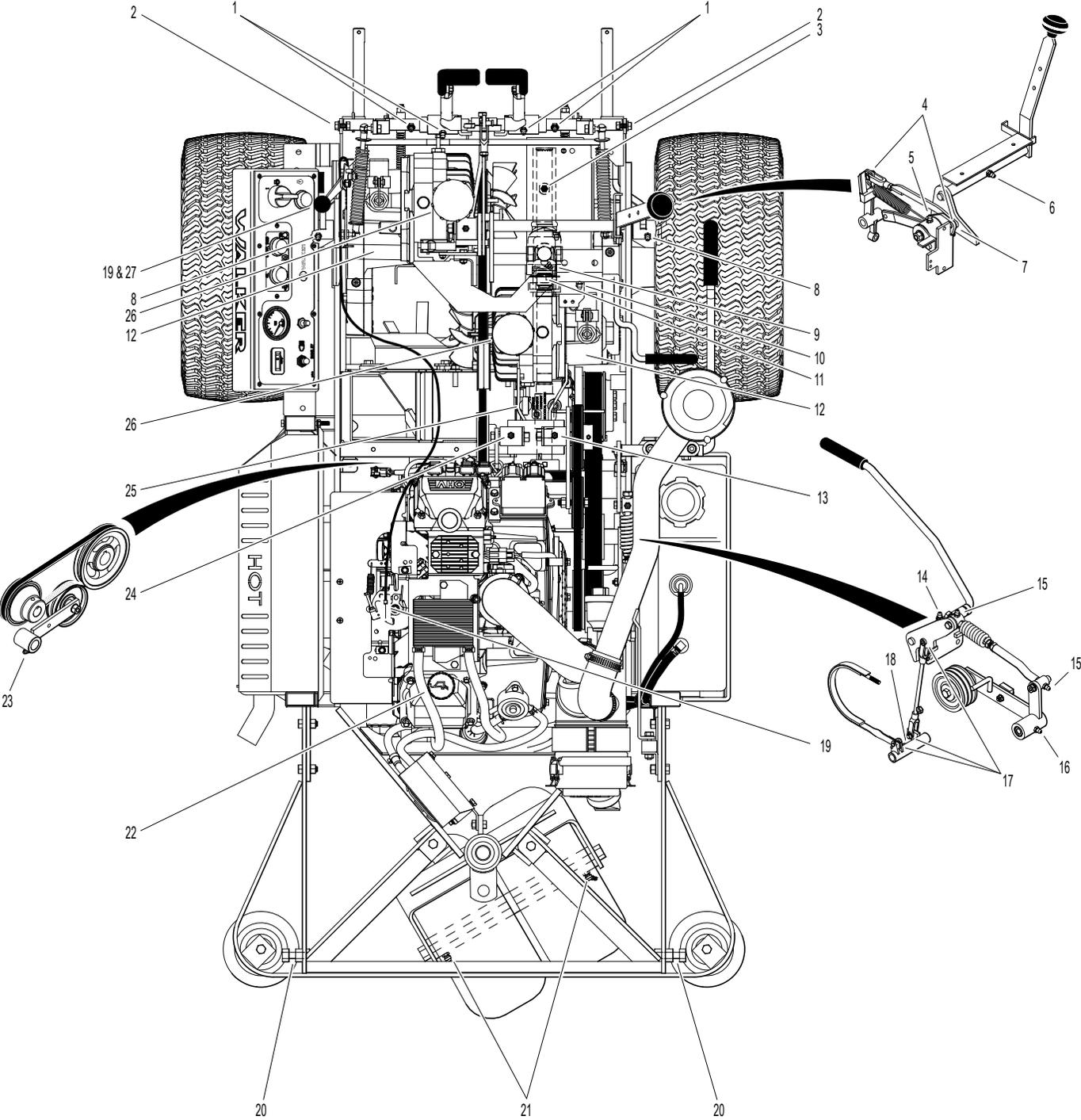

Beginning S/N 125598  
Effective Date 11-18-13  
Use only genuine Walker® replacement parts.

# WIRING SCHEMATIC

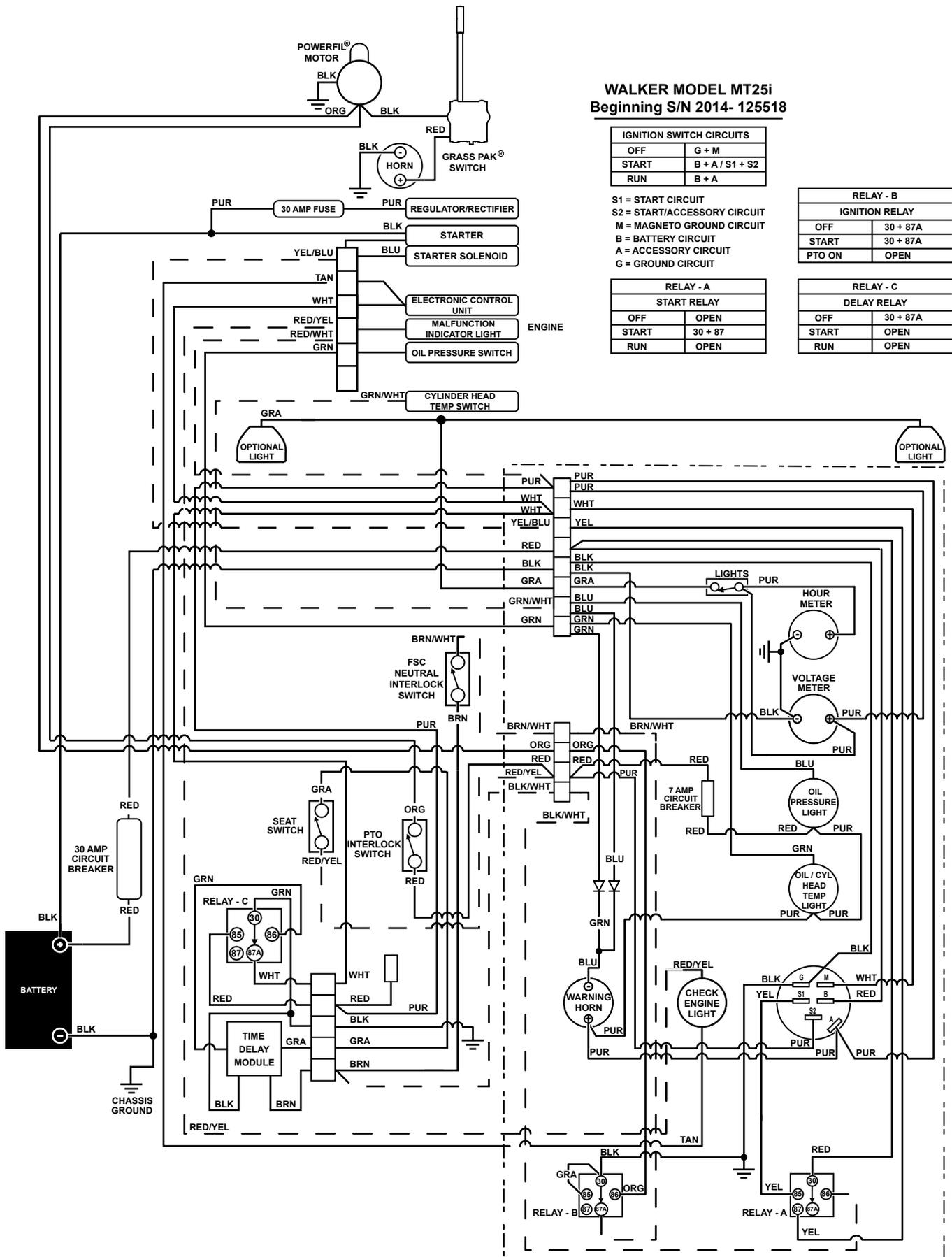

## WALKER MODEL MT25i Beginning S/N 2014- 125518

IGNITION SWITCH CIRCUITS	
OFF	G + M
START	B + A / S1 + S2
RUN	B + A

S1 = START CIRCUIT  
 S2 = START/ACCESSORY CIRCUIT  
 M = MAGNETO GROUND CIRCUIT  
 B = BATTERY CIRCUIT  
 A = ACCESSORY CIRCUIT  
 G = GROUND CIRCUIT

RELAY - A START RELAY	
OFF	OPEN
START	30 + 87
RUN	OPEN

RELAY - B IGNITION RELAY	
OFF	30 + 87A
START	30 + 87A
PTO ON	OPEN

RELAY - C DELAY RELAY	
OFF	30 + 87A
START	OPEN
RUN	OPEN

Beginning S/N 125598

Effective Date 11-18-13

Use only genuine Walker® replacement parts.



# OPERATOR'S NOTES

---

# LIMITED WARRANTY FOR WALKER COMMERCIAL RIDER MOWER

## 1. WHAT THIS WARRANTY COVERS, AND FOR HOW LONG:

Walker Manufacturing company will, at its option, repair or replace, without charge, any part covered by this warranty which is found to be defective in material and/or workmanship within one (1) year\* after date of sale to the original retail purchaser unless the product is used for rental purposes, in which case this warranty is limited to ninety (90) days. At Walker's request, customer will make the defective part available for inspection by Walker and/or return the defective part to Walker, transportation charges prepaid. All parts and components of the Walker Mower are covered by this warranty **except** the following components which are warranted separately by their respective manufacturers:

Kohler Engine  
Kubota Engine  
Kawasaki Engine  
Eaton Hydraulic Transmission  
Peerless Gearboxes  
Battery  
Tires

The available warranties covering these items are furnished with each mower. Walker does not assume any warranty obligation, liability or modification for these items, which are covered exclusively by the stated warranty of the respective manufacturers noted above.

\* An extended three (3) year warranty is offered on the Walker P/N 6200-9 Gear Axle Assembly.

## 2. WHAT THIS WARRANTY DOES NOT COVER:

- A. This warranty does not cover defects caused by depreciation or damage caused by normal wear, accidents, improper maintenance, improper use or abuse of the product, alterations, or failure to follow the instructions contained in the Operator's Manual for operation and maintenance.
- B. The customer shall pay any charges for making service calls and/or for transporting the mower to and from the place where the inspection and/or warranty work is performed.

## 3. HOW TO OBTAIN SERVICE UNDER THIS WARRANTY:

Warranty service can be arranged by contacting the dealer where you purchased the mower or by contacting Walker Manufacturing Company, 5925 East Harmony Road, Ft. Collins, CO 80528. Proof of the date of purchase may be required to verify warranty coverage.

## 4. WARRANTY LIMITATION:

- A. **THERE IS NO OTHER EXPRESS WARRANTY. ANY WARRANTY THAT MAY BE IMPLIED FROM THIS PURCHASE INCLUDING MERCHANTABILITY AND FITNESS FOR A PARTICULAR PURPOSE IS HEREBY LIMITED TO THE DURATION OF THIS WARRANTY AND TO THE EXTENT PERMITTED BY LAW ANY AND ALL IMPLIED WARRANTIES ARE EXCLUDED.** Some states do not allow limitations on how long an implied warranty lasts, so the above limitations may not apply to you.
- B. **WALKER WILL NOT BE LIABLE FOR ANY INCIDENTAL, CONSEQUENTIAL, OR SPECIAL DAMAGES AND/OR EXPENSES IN CONNECTION WITH THE PURCHASE OR USE OF THE MOWER.** Some states do not allow the exclusion or limitation of incidental or consequential damages, so the above limitation(s) or exclusion(s) may not apply to you.
- C. Only the warranty expressed in this limited warranty shall apply and no dealer, distributor, or individual is authorized to amend, modify, or extend this warranty in any way. Accordingly, additional statements such as dealer advertising or presentations, whether oral or written, do not constitute warranties by Walker, and should not be relied upon.
- D. This warranty gives you specific legal rights, and you may also have other rights which vary from state to state.

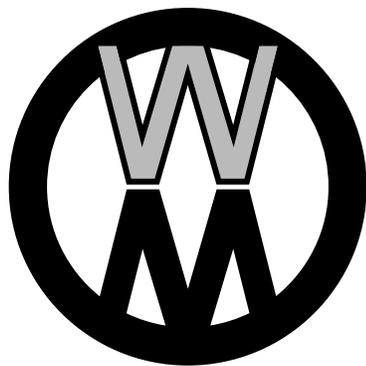

**WALKER**

**WALKER MFG. CO. • 5925 E. HARMONY ROAD, FORT COLLINS, CO 80528 • (970) 221-5614**  
**FORM NO. 111813      PRINTED IN USA      [www.walkermowers.com](http://www.walkermowers.com)      ©2014 WALKER MFG. CO**