

WALKER

Illustrated Parts Manual

D21d



Beginning S/N: 124860
Effective Date: 10.04.13
P/N 7000-12

KEY TO ABBREVIATIONS USED IN THIS MANUAL

<i>Abbreviation</i>	<i>What it Represents</i>
° (Dimension)	Degrees (Angle)
" (Dimension)	inches
(-)	Negative (Polarity)
(+)	Positive (Polarity)
AT	All-Terrain
CCW	Counter-clockwise
Conn	Connector
CW	Clockwise
D	Diameter
DC	Deck, Collection (number refers to size in inches)
DM	Deck, Mulching (number refers to size in inches)
DR	Deck, Rear Discharge (number refers to size in inches)
DS	Deck, Side Discharge (number refers to size in inches)
DU	Garlock (Bearing)
ESNA (Fastener)	Nylon Insert Locknut
FSC	Forward Speed Control
GA	Gauge
gal	gallon
GHS	Grass Handling System
GR (Fastener)	Grade
HD	Heavy Duty
HP	Horse Power
ID	Identification or Inside Diameter
L	Length
LH	Left Hand (orientated with operator on seat)
LP	Low Profile
mm (Dimension)	millimeters
MS (Fastener)	Machine Screw
NS (as part number)	Item is not sold by Walker Manufacturing
OD	Outside Diameter
oz	ounce
PFH (Fastener)	Phillips Flat Head
P/N	Part Number
PPH (Fastener)	Phillips Pan Head
PTH (Fastener)	Phillips Truss Head
PTO	Power Take-Off
QKS	Quick Slide
qt	quart
RH	Right Hand (orientated with operator on seat)
SAE (Fastener)	Society of Automotive Engineers
SBH (Fastener)	Socket Button Head (Bolt)
SD	Side Discharge
SFH (Fastener)	Slotted Flat Head
SHC (Fastener)	Socket Head Cap
SHL (Fastener)	Shoulder (Bolt)
SM (Fastener)	Sheet Metal (Screw)
S/N	Serial Number
Spg	Spring
SQH (Fastener)	Square Head
SS (Fastener)	Stainless Steel
ST (Fastener)	Self-Tapping (Screw)
Term	Terminal
V	Volts

NOTE: In some instances, combinations of abbreviations may be used (e.g. PPHMS - Phillips Pan Head Machine Screw).

Beginning S/N 124860

Effective Date 10-04-13

Use only genuine **Walker**[®] replacement parts.

ILLUSTRATED PARTS LIST

<i>Section of Tractor Covered</i>	<i>Page</i>	<i>Section of Tractor Covered</i>	<i>Page</i>
Decals		Electrical Components	
Tractor Decals	2	Electrical Assembly	36
Body / Chassis Assemblies		Electrical Assemblies (GHS 10.0 Bushel Components).....	38
Body / Chassis Assembly (GHS Models)	4	Electrical Connectors.....	40
Rear Body Assembly (GHS Models)	6	Maintenance	
Body Assembly (SD Models).....	8	Lubrication Points	42
Tractor Components		Wiring Schematic.....	44
Main Component Power Transmission (GHS Models)	10	Warranty	
(SD Models)	12	Limited Warranty.....	45
Engine Group.....	14		
Air Intake And Exhaust Group	16		
Radiator Group	18		
Hydrostatic Ground Drive Assemblies.....	20		
Steering Control Assemblies	22		
Throttle Control Assembly.....	24		
Parking Brake Assembly	26		
GHS Group	28		
GHS Powerfil® Assembly (10.0)	30		
GHS 10.0 Bushel Catcher Assembly.....	32		
Instrument Panel Assembly	34		

TRACTOR DECALS

ITEM NO.	PART NO.	DESCRIPTION	LOCATION	NO. REQ'D. GHS	NO. REQ'D SD
Walker Product Decals					
1	8600-33	RH Fender	Body, RH Side Near Seat	1	1
2	5800	Walker Mower (4" Round)	Utility Bed (one on each side)	0	2
3	5856-1	Made in USA	Body	1	1
4	5800-11	Walker (8" Round)	10.0 Bushel Catcher (one on each side)	2	0
5	8821-9	Decal, D21d	Body	1	1
Danger Decals Warning Decals Caution Decals					
6	8600-34	Warning, Read Manual	Body	1	1
7	5810-3	Decal, Hydro Warning	Bridge Assembly and LH Gear Axle Drive Assembly	2	2
8	8600-10	Danger, Pinch Point	10.0 Bushel Catcher Mounting Frame Assembly (one on each side)	2	0
9	8600-4	Danger, Rotating Blower Blades	Body, Near Body Chute	1	0
Maintenance Decals					
10	8600-30	Parking Brake	Body, RH Side Below Seat	1	1
11	8600-23	Danger, Body Latch	Body, RH Side Below Seat	1	1
12	NS	Caution (19426-87903 Kubota)	Air Cleaner Cover	1	1
13	NS	Caution (19426-87881 Kubota)	Radiator	1	1
14	8600-16	Front Body Closure	Rear Cross Member, Body	1	1
15	7827	Oil Level	Jackshaft Support	1	1
16	5810-1	Axle Oil Level	Gear Axle Drive Assemblies (one on each)	2	2
17	8600-31	Throttle	Body, LH Side	1	1
18	6875	PTO Alignment Arrow	Universal Joint Tube Assembly	1	1
19	NS	Sealed Reservoir	Hydrostatic Drives (one on each)	2	2
20	5869	Removable Screen	10.0 Bushel Catcher Removable Screen	1	0

NOTE: All parts requiring decals are shipped with decals applied.

TRACTOR DECALS

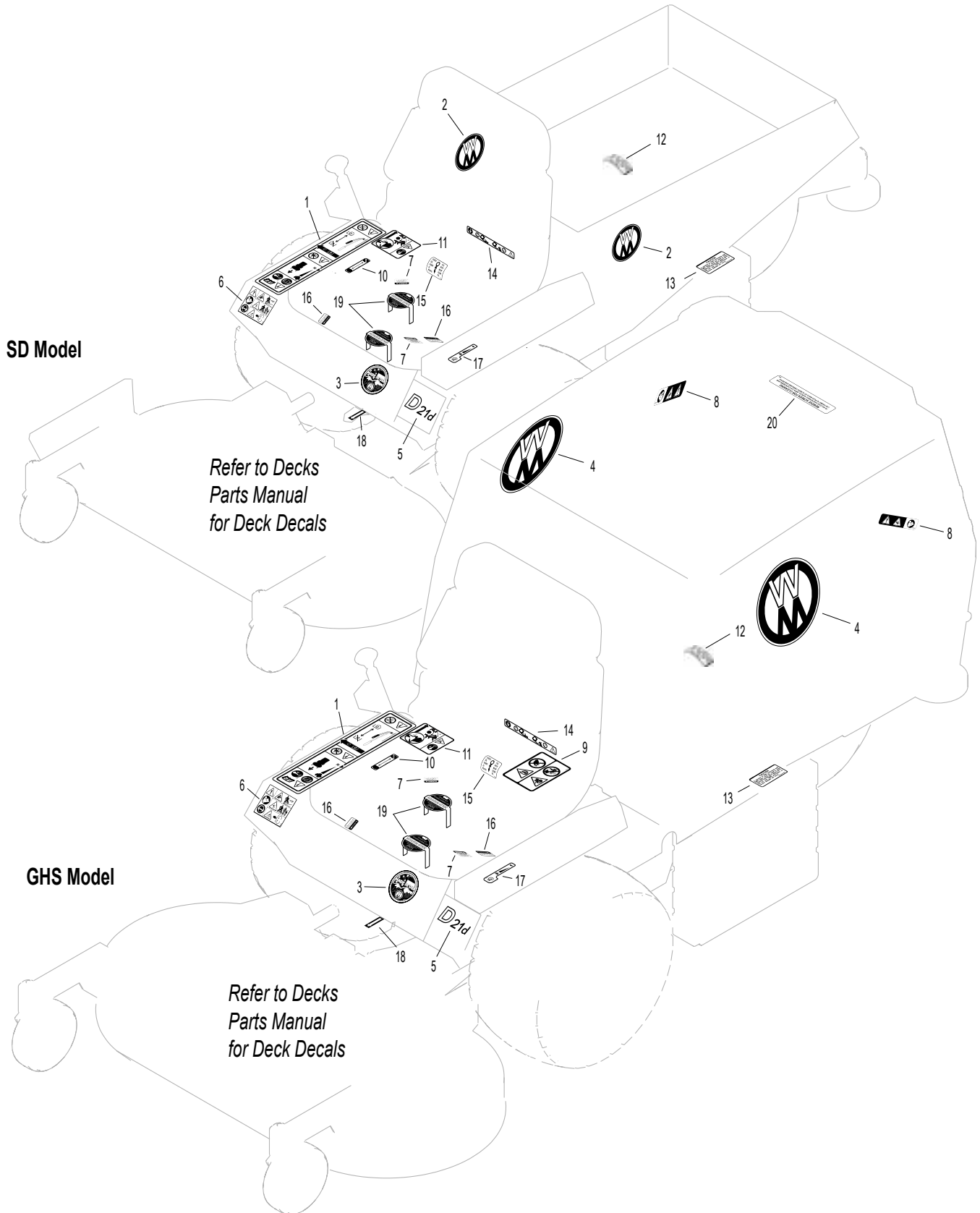

BODY / CHASSIS ASSEMBLY (GHS MODELS)

ITEM NO.	PART NO.	DESCRIPTION	NO. REQ'D	ITEM NO.	PART NO.	DESCRIPTION	NO. REQ'D
Seat Assembly				45	8037	Bearing Cone (3/4 ID)	4
1	6103-14	Suspension Seat	1	46	8037-2	Bearing Race	4
2	6103-35	Suspension Seat Mount	2	47	8035	Tail Wheel & Tire (13 x 5.00-6) (With Bearing Race)	2
3	7440-7	Shock Mount	4		7035-1	Tail Wheel Tire (13 x 5.00-6)	**
4	6105-1	Shoulder Washer	2		8036	Tail Wheel & Hub (6 x 3.25) (Includes Items # 40 & 46)	**
Rear Bumper Assembly (GHS Models Only)*					7420-20	Dual Tail Wheel & Tire Assembly (Includes Items # 42-45 & 47-49)	**
5	NS	Recovery Tank Mount (19449-72502 Kubota)	1	48	8768-2	Seal, Reverse Lip	2
6	7047-5	Mount Plate	1	49	8038	Tail Wheel Axle (3/4 x 10-3/8)	1
7	7516-7	7.0 / 10.0 Rear Bumper	1	50	7070	Wheel & Tire (18 x 9.50-8)	2
8	7516-5	Catcher Pivot Bushing	2		7070-1	Drive Tire (18 x 9.50-8)	**
9	5162	Roller Wheel (5" Rubber)	2		5070-4	Wide Wheel (8 x 7)	**
10	7517-2	Catcher Pivot Plate	2	51	7300-6	Chassis Frame (2-1/2 Side Bars)	1
11	5832	Cable Clamp (1/2)	2	Fasteners			
Body Assembly					F002	10-24 Keps Nut	3
12	7833-2	Cable Clamp (1 x 1/4)	1	F004	1/4-20 Keps Nut	6	
13	5977-3	Grommet (9/16)	1	F005	1/4-20 ESNA Nut	1	
14	6105-3	Harness Clip	2	F009	5/16-18 Whiz Locknut	15	
15	NS	Body ID Plate	1	F012	3/8-16 Keps Nut	8	
16	5845	Rubber Bumper (1.50 OD x 1.25)	4	F013	3/8-16 Whiz Locknut	2	
17	7422	Panel Guard	1	F014	3/8-16 ESNA Nut	4	
18	5989-4	Dome Plug (3/8)	4	F020	5/16-18 ESNA Nut	1	
19	5989-3	Dome Plug (5/16)	2	F025	10-24 x 3/8 PPHMS	1	
20	7146	13mm Ball Stud	2	F026	10-24 x 1/2 PPHMS	2	
21	7145	Gas Spring Assembly (Includes Item # 20)	1	F029	1/4-20 x 1/2 Hex Bolt	2	
22	7844	Rubber Bumper (1.25 OD x .250)	1	F031	1/4-20 x 5/8 Hex Bolt	1	
23	7854	Plastic Tip, Red	1	F034	5/16-18 x 3/4 Hex Bolt	6	
24	7222	Extension Spring (1/4 x 3)	1	F038	3/8-16 x 1 Hex Bolt	6	
25	7383-3	Body Latch Hook (2-1/2 Side Bars)	1	F040	3/8-16 x 1-1/2 Hex Bolt	2	
26	5989-9	Dome Plug (1/4)	8	F042	3/8-16 x 2-1/4 Hex Bolt	2	
27	7100-7	Front Body	1	F050	1/4 SAE Washer	1	
28	5180	Edge Molding, Lever Opening	2	F051	3/8 SAE Washer	2	
29	5989-55	Dome Plug (1/2)	1	F059	3/8 Wave Spring Washer	2	
30	5989-5	Dome Plug (7/16)	1	F093	5/16-18 x 1 Hex Bolt	1	
Tilt-Up Latch Assembly***					F104	1/4-20 x 3/4 PFH Bolt	4
31	5847	Plastic Tip	1	F151	3/8-16 x 7/8 Hex Bolt	2	
32	5744-20	Spring Arm, Tilt-Up Latch	1	F157	1/2-20 x 1-1/4 Wheel Lug Bolt	8	
33	5744-10	Spring Pivot Bushing	1	F191	3/8 x 1-1/2 x 3/16 Washer	2	
34	5744-15	Compression Spring (3/8 x 5/8)	1	F205	5/16-18 x 1/4 Set Screw, Knurl Point	2	
35	5744-13	Mount Angle, LH	1	F206	#2 x 3/16 Drive Pin	2	
36	5744-12	Hook, Tilt-Up Latch	1	F218	7/16 Split Lock Washer	2	
37	5744-14	Mount Angle, RH	1	F219	7/16-14 x 1-1/4 Hex Bolt	2	
Chassis Assembly					F241	.375 x .875 x .10 Washer	4
38	5267-1	Retainer Collar (1") (Includes Item # F413)	1	F341	Coil Roll Pin (7/64 x 9/16)	1	
39	5270-1	Pivot Bearing	2	F342	5/16 Conical Washer	2	
40	7420	Tail Wheel Fork	1	F413	5/16-24 x 5/16 Set Screw	2	
41	5830-3	Grease Fitting (45 Degree)	2	F429	5/16-18 x 1/2 SFH Screw	4	
42	8039	Nut, Tail Wheel Axle	2	* Rear Bumper Assembly for SD Models is not shown here. Refer to BODY ASSEMBLY (SD MODELS) , Page 8.			
43	8037-1	Seal, Outer (1-3/4 x 1-1/8)	2	** Service Part Only			
44	8038-1	Spacer, Tail Wheel Axle (.750 ID x 1.125 OD)	2	*** Complete Tilt-Up Latch Assembly Kit available by ordering kit # 5747.			

BODY / CHASSIS ASSEMBLY (GHS MODELS)

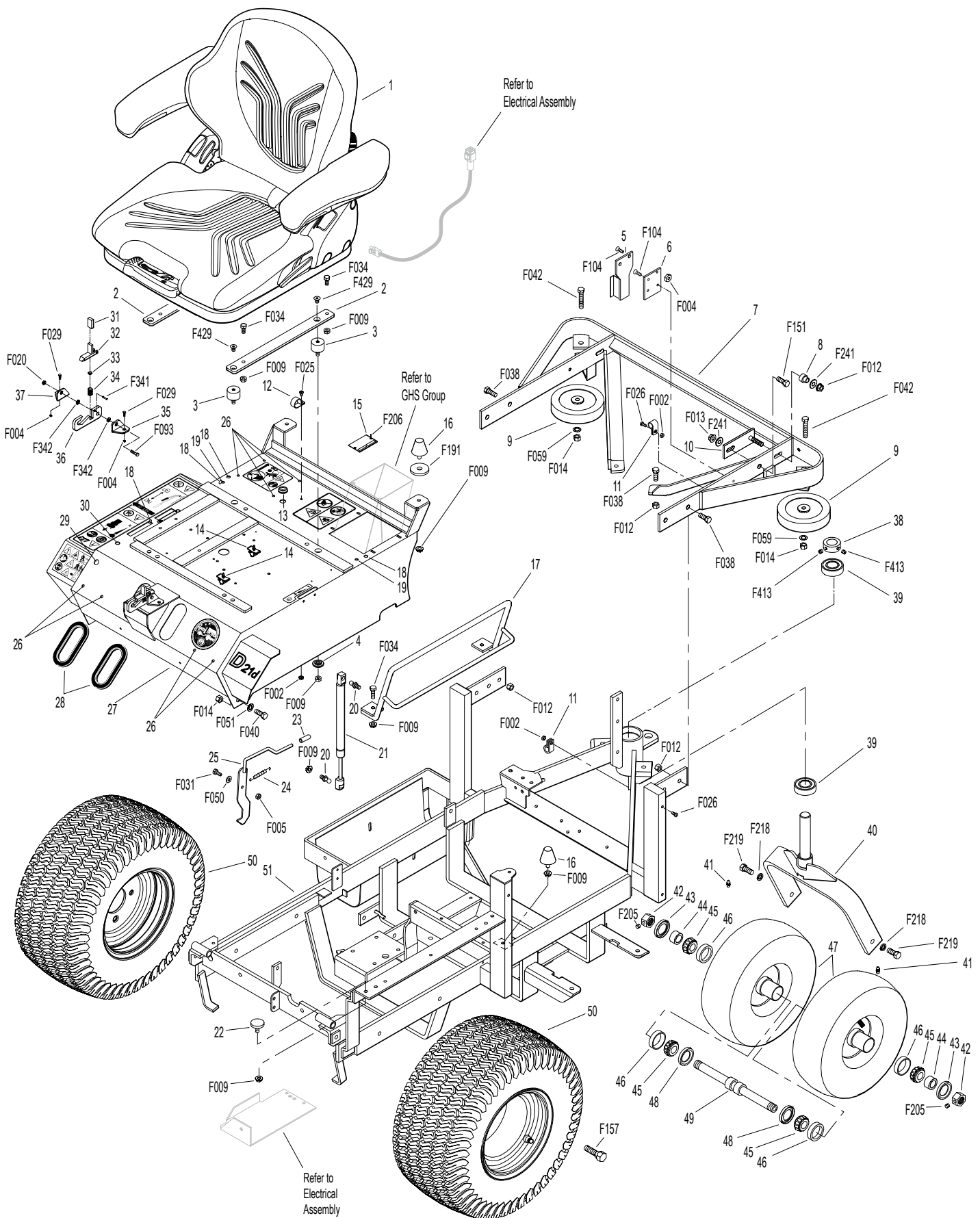

Beginning S/N 124860
 Effective Date 10-04-13
 Use only genuine Walker® replacement parts.

REAR BODY ASSEMBLY (GHS MODELS)

ITEM NO.	PART NO.	DESCRIPTION	NO. REQ'D	ITEM NO.	PART NO.	DESCRIPTION	NO. REQ'D
Rear Body Assembly (GHS Models)				Fasteners			
1	8515-13	Catcher Handle Plate, LH	1	F002		10-24 Keps Nut	6
2	8515-14	Catcher Handle Plate, RH	1	F004		1/4-20 Keps Nut	5
3	8615-2	Catcher Support Frame, 10.0	1	F009		5/16-18 Whiz Locknut	4
4	7190-2	Insulation Foam Pad, RH	1	F025		10-24 x 3/8 PPHMS	6
5	7190-1	Insulation Foam Pad, LH	1	F031		1/4-20 x 5/8 Hex Bolt	2
6	7146	13mm Ball Stud	2	F032		1/4-20 x 3/4 Hex Bolt	1
7	7145	Gas Spring Assembly (Includes Item # 6)	1	F178		1/4 x 1 Fender Washer	1
8	5845	Rubber Bumper (1.50 x 1.25)	1	F390		1/4-20 x 7/8 Carriage Bolt	2
9	7105-5	Rear Body Panel	1				

NOTE: Rear Bumper Assembly for GHS Models is not shown here.
Refer to **BODY / CHASSIS ASSEMBLY (GHS MODELS)**,
Page 4.

REAR BODY ASSEMBLY (GHS MODELS)

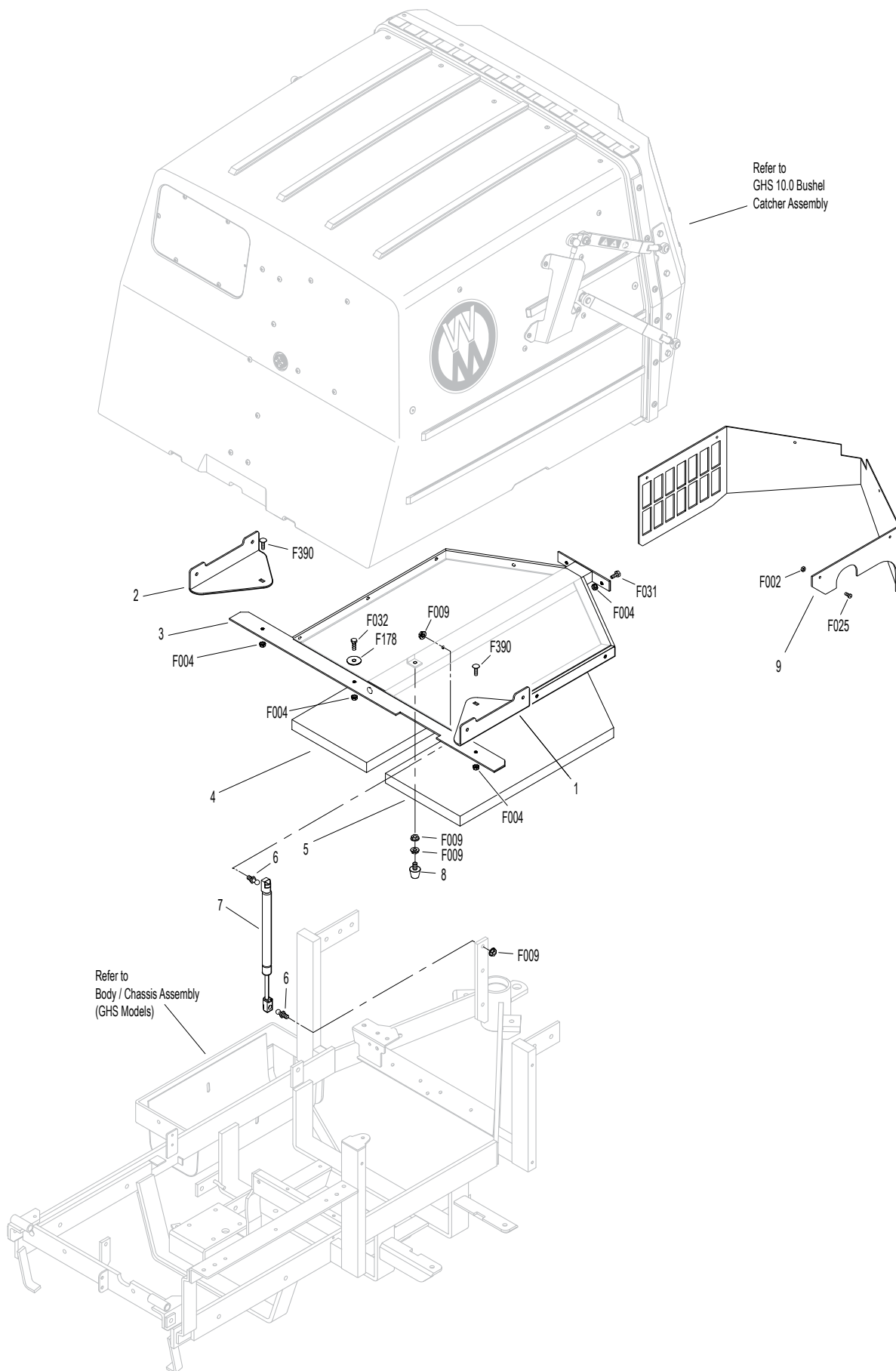

Beginning S/N 124860
Effective Date 10-04-13
Use only genuine **Walker**® replacement parts.

BODY ASSEMBLY (SD MODELS)

ITEM NO.	PART NO.	DESCRIPTION	NO. REQ'D	ITEM NO.	PART NO.	DESCRIPTION	NO. REQ'D
Utility Bed Assembly				Fasteners			
1	8650-10	Bed Liner (21.5 x 27.5)	1	F002		10-24 Keps Nut	11
2	7650-3	Utility Bed (Includes Item # 1)	1	F004		1/4-20 Keps Nut	4
3	7190-2	Insulation Foam Pad, RH	1	F009		5/16-18 Whiz Locknut	4
4	7190-1	Insulation Foam Pad, LH	1	F012		3/8-16 Keps Nut	6
Rear Bumper Assembly (SD Models)				F013		3/8-16 Whiz Locknut	4
5	7153-3	Cover Plate	1	F014		3/8-16 ESNA Nut	2
6	5845	Rubber Bumper (1.50 x 1.25)	1	F025		10-24 x 3/8 PPHMS	6
7	7146	13mm Ball Stud	2	F026		10-24 x 1/2 PPHMS	1
8	7145	Gas Spring Assembly (Includes Item # 7)	1	F038		3/8-16 x 1 Hex Bolt	6
9	7521-5	Rear Bumper	1	F040		3/8-16 x 1-1/2 Hex Bolt	2
10	NS	Recovery Tank Mount (19449-72502 Kubota)	1	F042		3/8-16 x 2-1/4 Hex Bolt	2
11	7047-5	Mount Plate	1	F051		3/8 SAE Washer	4
12	5832	Cable Clamp (1/2)	1	F059		3/8 Wave Spring Washer	2
13	5162	Roller Wheel (5" Rubber)	2	F104		1/4-20 x 3/4 PFH Bolt	4
14	7105-5	Rear Body Panel	1	F128		10-24 x 3/8 PTHMS	4
NOTE: Refer to BODY / CHASSIS ASSEMBLY (GHS MODELS) , Page 4 for all common parts used on both models.							

BODY ASSEMBLY (SD MODELS)

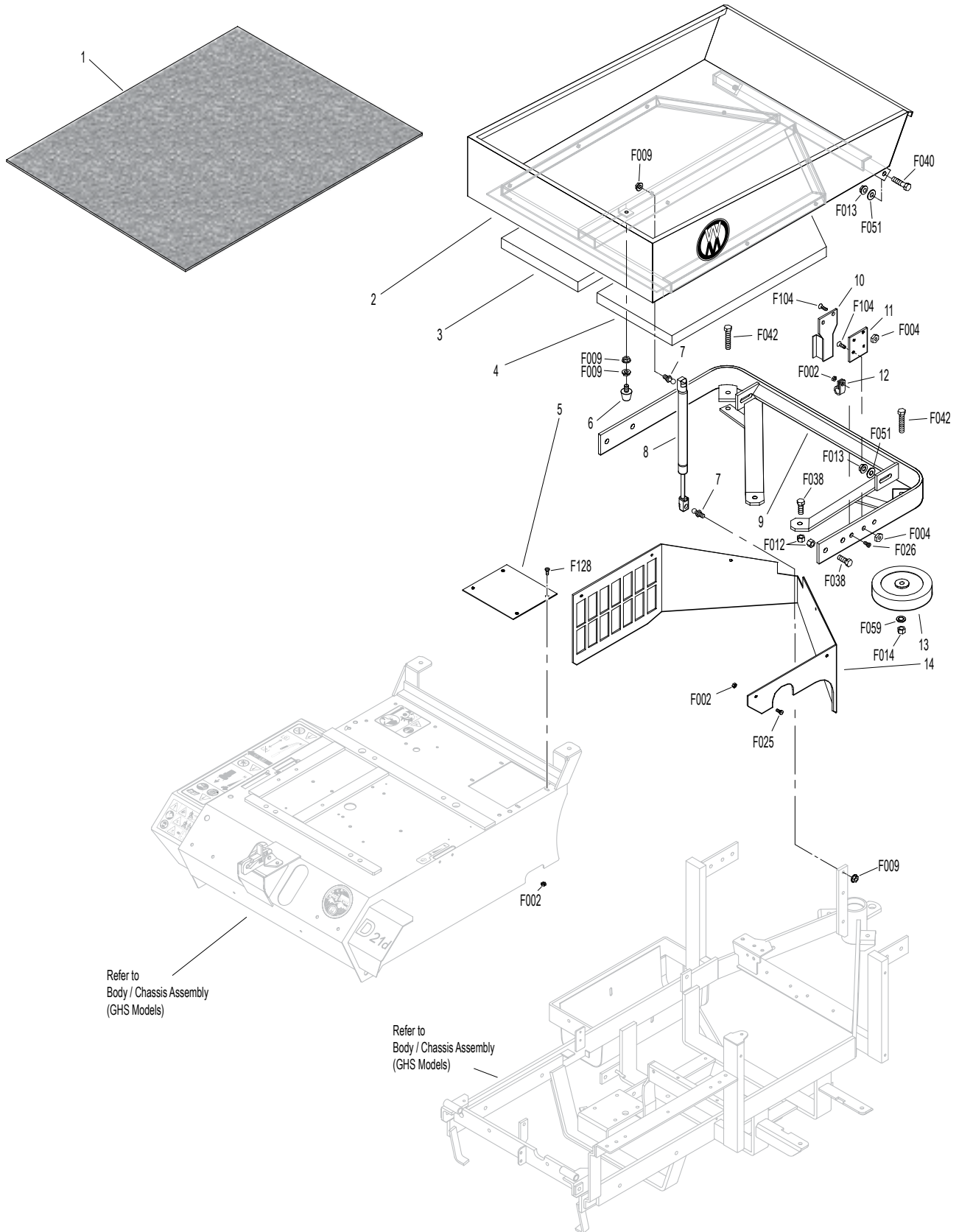

Beginning S/N 124860
 Effective Date 10-04-13
 Use only genuine **Walker**® replacement parts.

MAIN COMPONENT POWER TRANSMISSION (GHS MODELS)

ITEM NO.	PART NO.	DESCRIPTION	NO. REQ'D	ITEM NO.	PART NO.	DESCRIPTION	NO. REQ'D
Clutch Lever Assembly				Ground Drive Release Assembly			
1	5830	Grease Fitting	4	37	7245-1	Idler Pulley (3/8 Groove)	1
2	5229	Extension Spring (1/2 x 2-1/4)	1	38	7374	Ground Drive Release Arm	1
3	7243	Clutch Idler Pulley	1	39	7390	Idler Arm Guide	1
4	7368-5	PTO Belt Tightener (1.75 TAB)	1	40	7406-1	Handle Grip, Red	1
5	7201-3	Fiberglide Bearing	6	41	7376	Handle, Ground Drive Release (Includes Item # 40)	1
6	7201-6	Inner Race (3-5/8)	1	42	5221	Extension Spring (3/4 x 4)	1
7	7303-9	Clutch Actuator Block	1	43	7854	Plastic Tip, Red	1
8	5830-3	Grease Fitting (45 Degree)	2	44	7375	Spring Arm, Ground Drive Idler Release (Includes Item # 43)	1
9	7226	Compression Spring (3/4 x 2-1/2)	1	45	7225	Compression Spring (7/16 x 1/2)	1
10	7380	Knuckle Joint	1	Fasteners			
11	7303-7	Clutch Actuator Rod	1	F002	10-24 Keps Nut		1
12	7378	Pivot Bearing (7/16 x 9/16)	1	F004	1/4-20 Keps Nut		2
13	7358	Clutch Lever (Includes Items # 1 & 14)	1	F005	1/4-20 ESNA Nut		2
14	4850	Handle Grip	1	F009	5/16-18 Whiz Locknut		3
PTO Drive Shaft Assembly				F012	3/8-16 Keps Nut		3
15	7050-1	Dipstick, Gearbox	1	F013	3/8-16 Whiz Locknut		2
16	7377-1	Brake Band Guide	1	F029	1/4-20 x 1/2 Hex Bolt		1
17	7050-11	PTO Gearbox / Flange Pulley	1	F041	3/8-16 x 1-3/4 Hex Bolt		1
18	7248	Ground Drive Belt, Micro-V	1	F042	3/8-16 x 2-1/4 Hex Bolt		2
19	7275-9	Quick Coupler Installation Tool	**	F047	3/8-16 x 4-1/2 Hex Bolt		1
20	7275-16	Universal Joint Tube Assembly / Spline	1	F050	1/4 SAE Washer		1
21	7303-2	Brake Band (13-5/8)	1	F060	AN960516 Washer		2
22	7236-1	PTO Drive Pulley (4-1/2/3V) (Includes Items # F168 & F226)	1	F061	1/4 Internal Star Lock Washer		1
23	7237-30	Engine Pulley (Flywheel Mount) (Includes Item # F221)	1	F067	3/16 x 3/16 x 1 Key		2
24	7230	Engine PTO Belt	1	F069	3/32 x 1/2 Cotter Pin		1
25	6238	Drive Belt (3VX345)	1	F108	3/8-16 x 2 Hex Bolt		1
Jackshaft Assembly				F116	1/4-20 x 1-1/4 Hex Bolt		1
26	7240-4	Jackshaft Drive Pulley (3.3/3V) (Includes Items # F067 & F171)	1	F167	5/16-18 Hex Nut		1
27	5268	Bearing with Collar (3/4)	2	F168	5/16 Split Lock Washer		9
28	7273	Jackshaft (3/4 x 8-7/8)	1	F171	5/16-18 x 3/8 Set Screw		4
29	7393-7	Hydro Jackshaft Mount	1	F178	1/4 x 1 Fender Washer		1
	7394-1	Hydro Jackshaft Mount Assembly (Includes Items # 1, 5, 27-29 & 31)	*	F187	1/4-20 x 1-1/2 Hex Bolt		2
30	5841	Retainer Washer (3/8 x 1-1/4)	2	F221	M8 x 1.25 x 16 PFH Bolt		5
31	7201-4	Inner Race (1-1/2)	2	F226	5/16-18 x 7/8 Hex Bolt		9
32	7349-50	Idler Arm	1	F245	3/8-24 x 7/8 SFH Cap Screw		1
33	7349-2	Extension Spring (3/4 x 4)	1	F252	10-24 x 3/4 PFHMS		1
34	6325-3	Spacer Bushing (9/16)	1	F255	5/16-18 x 1-1/2 Hex Bolt		2
35	5245	Idler Pulley (3")	1	F275	5/16-18 x 2 Hex Bolt		1
36	7241-2	Transmission Drive Pulley (3-1/4MV) (Includes Items # F067 & F171)	1	F288	5/16-18 ESNA Jam Nut		1

* Service Part Only

** The Quick Coupler Installation Tool is used to assist the installation of the Quick Coupler Tube and PTO Shaft connection by holding the disconnect ring in the retracted position when joined to the tractor spline shaft on the PTO gearbox.

Beginning S/N 124860

Effective Date 10-04-13

Use only genuine **Walker**® replacement parts.

MAIN COMPONENT POWER TRANSMISSION (GHS MODELS)

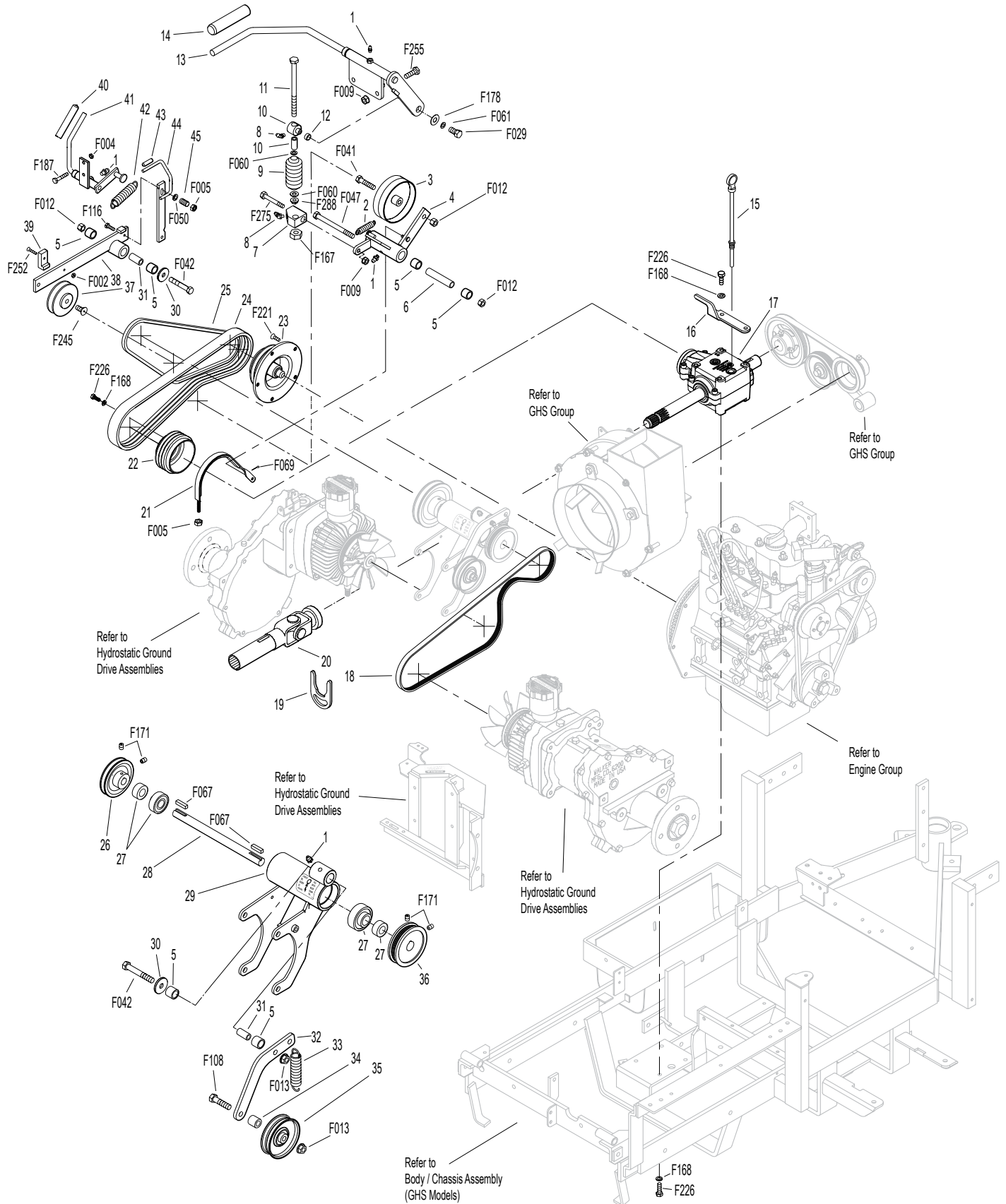

Beginning S/N 124860
 Effective Date 10-04-13
 Use only genuine **Walker**® replacement parts.

MAIN COMPONENT POWER TRANSMISSION (SD MODELS)

ITEM NO.	PART NO.	DESCRIPTION	NO. REQ'D	ITEM NO.	PART NO.	DESCRIPTION	NO. REQ'D
Clutch Lever Assembly				Ground Drive Release Assembly			
1	5830	Grease Fitting	4	40	7245-1	Idler Pulley (3/8 Groove)	1
2	5229	Extension Spring (1/2 x 2-1/4)	1	41	7374	Ground Drive Release Arm	1
3	7243	Clutch Idler Pulley	1	42	7390	Idler Arm Guide	1
4	7368-5	PTO Belt Tightener (1.75 TAB)	1	43	7406-1	Handle Grip, Red	1
5	7201-3	Fiberglide Bearing	6	44	7376	Handle, Ground Drive Release (Includes Item # 43)	1
6	7201-6	Inner Race (3-5/8)	1	45	5221	Extension Spring (3/4 x 4)	1
7	7303-9	Clutch Actuator Block	1	46	7854	Plastic Tip, Red	1
8	5830-3	Grease Fitting (45 Degree)	2	47	7375	Spring Arm, Ground Drive Idler Release (Includes Item # 46)	1
9	7226	Compression Spring (3/4 x 2-1/2)	1	48	7225	Compression Spring (7/16 x 1/2)	1
10	7380	Knuckle Joint	1	Fasteners			
11	7303-7	Clutch Actuator Rod	1	F002	10-24 Keps Nut		1
12	7378	Pivot Bearing (7/16 x 9/16)	1	F004	1/4-20 Keps Nut		4
13	7358	Clutch Lever (Includes Items # 1 & 14)	1	F005	1/4-20 ESNA Nut		2
14	4850	Handle Grip	1	F009	5/16-18 Whiz Locknut		3
PTO Drive Shaft Assembly				F012	3/8-16 Keps Nut		3
15	7050-1	Dipstick, Gearbox	1	F013	3/8-16 Whiz Locknut		2
16	7377-1	Brake Band Guide	1	F029	1/4-20 x 1/2 Hex Bolt		1
17	7050-11	PTO Gearbox / Flange Pulley	1	F041	3/8-16 x 1-3/4 Hex Bolt		1
18	7248	Ground Drive Belt, Micro-V	1	F042	3/8-16 x 2-1/4 Hex Bolt		2
19	7275-9	Quick Coupler Installation Tool	**	F047	3/8-16 x 4-1/2 Hex Bolt		1
20	7275-16	Universal Joint Tube Assembly / Spline	1	F050	1/4 SAE Washer		1
21	7303-2	Brake Band (13-5/8)	1	F060	AN960516 Washer		2
22	7236-1	PTO Drive Pulley (4-1/2/3V) (Includes Items # F168 & F226)	1	F061	1/4 Internal Star Lock Washer		1
23	7237-30	Engine Pulley (Flywheel Mount) (Includes Item # F221)	1	F067	3/16 x 3/16 x 1 Key		2
24	7230	Engine PTO Belt	1	F069	3/32 x 1/2 Cotter Pin		1
25	6238	Drive Belt (3VX345)	1	F090	1/4-20 x 2-1/2 Hex Bolt		2
Jackshaft Assembly				F108	3/8-16 x 2 Hex Bolt		1
26	7240-4	Jackshaft Drive Pulley (3.3/3V) (Includes Items # F067 & F171)	1	F116	1/4-20 x 1-1/4 Hex Bolt		1
27	5268	Bearing with Collar (3/4)	2	F167	5/16-18 Hex Nut		1
28	7273	Jackshaft (3/4 x 8-7/8)	1	F168	5/16 Split Lock Washer		9
29	7393-7	Hydro Jackshaft Mount	1	F171	5/16-18 x 3/8 Set Screw		4
	7394-1	Hydro Jackshaft Mount Assembly (Includes Items # 1, 5, 27-29 & 31)	*	F178	1/4 x 1 Fender Washer		1
30	5841	Retainer Washer (3/8 x 1-1/4)	2	F187	1/4-20 x 1-1/2 Hex Bolt		2
31	7201-4	Inner Race (1-1/2)	2	F221	M8 x 1.25 x 16 PFH Bolt		5
32	7349-50	Idler Arm	1	F226	5/16-18 x 7/8 Hex Bolt		9
33	5221-1	Extension Spring (3/4 x 5)	1	F245	3/8-24 x 7/8 SFH Cap Screw		1
34	6325-3	Spacer Bushing (9/16)	1	F252	10-24 x 3/4 PFHMS		1
35	5245	Idler Pulley (3")	1	F255	5/16-18 x 1-1/2 Hex Bolt		2
36	7394-6	Idler Pulley Spring Mount	1	F275	5/16-18 x 2 Hex Bolt		1
37	7833	Cable Clamp (7/8 x 1/4)	1	F288	5/16-18 ESNA Jam Nut		1
38	7241-2	Transmission Drive Pulley (3-1/4MV) (Includes Items # F067 & F171)	1	* Service Part Only			
39	8539	Starter Relay Mount	1	** The Quick Coupler Installation Tool is used to assist the installation of the Quick Coupler Tube and PTO Shaft connection by holding the disconnect ring in the retracted position when joined to the tractor spline shaft on the PTO gearbox.			

Beginning S/N 124860

Effective Date 10-04-13

Use only genuine **Walker**® replacement parts.

ENGINE GROUP

ITEM NO.	PART NO.	DESCRIPTION	NO. REQ'D	ITEM NO.	PART NO.	DESCRIPTION	NO. REQ'D
Engine Assembly				Fasteners			
1	7929-1	Actuating Solenoid	1	F002		10-24 Keps Nut	1
2	7305-3	Inline Ball Joint	1	F003		1/4-28 Hex Nut	1
3	7343-1	Solenoid Mount	1	F004		1/4-20 Keps Nut	9
4	7305-1	Solenoid Linkage Rod	1	F009		5/16-18 Whiz Locknut	4
5	NS	Kubota Diesel Engine (D 722 Kubota)	1	F025		10-24 x 3/8 PPHMS	1
6	7341	Throttle Cable Mount Bracket	1	F027		10-24 x 5/8 PPHMS	1
7	5975-3	Cable Tie (50# x 7")	2	F029		1/4-20 x 1/2 Hex Bolt	6
Fuel Tank Assembly				F031		1/4-20 x 5/8 Hex Bolt	5
8	5832	Cable Clamp (1/2)	1	F032		1/4-20 x 3/4 Hex Bolt	1
9	5083-8	Tank Tube (13")	1	F050		1/4 SAE Washer	1
10	5879-3	Hose Clamp (1/2)	2	F052		5/16 Ext. Star Lock Washer	2
11	M111	Fuel Line (1/4 x 16-1/2)	**	F061		1/4 Internal Star Lock Washer	4
12	7833	Cable Clamp (7/8 x 1/4)	2	F069		3/32 x 1/2 Cotter Pin	1
13	M113	Fuel Line (3/16 x 32)	**	F079		A/A66D Aluminum Pop Rivet	2
14	5879-2	Hose Clamp, Silver (7/16)	2	F091		5/16-18 x 5/8 Hex Bolt	2
15	7840-2	Hose Clamp (1/4 to 5/8)	6	F182		1/4 x 5/8 x 1/8 Washer	2
16	M247	Fuel Line (5/16 x 14-1/2)	**	F235		5/16-18 x 2-1/2 Hex Bolt	1
17	NS	Fuel Filter (19204-43010 Kubota)	1	F324		M8 x 1.25 x 12 Hex Bolt	2
18	M247	Fuel Line (5/16 x 25-1/2)	**	* Service Part Only			
19	7021	Fuel Filter (15231-43560 Kubota)	1	** Required hose specifications:			
20	7389	Splash Guard	1	M111 - 1/4" ID fuel/oil/vapor hose (Gates 4219-0103 or equivalent)			
21	7048	Trash Guard	1	M113 - 3/16" ID fuel/oil/vapor hose (Gates 4219-0093 or equivalent)			
22	M247	Fuel Line (5/16 x 17-1/2)	**	M247 - 5/16" ID low permeation (<15g/m ² /day) fuel hose (Parker 38905 or equivalent)			
23	NS	Fuel Pump (12691-52031 Kubota)	1	NOTE: Refer to ELECTRICAL CONNECTORS , Page 40 for identification of all Electrical Wiring Service Parts.			
24	7020	Fuel Filter (In-Line)	1	NOTE: Decals for this assembly are not shown here. Refer to TRACTOR DECALS , Page 2 for Decal listing and placement information.			
25	5086-7	Hose (1/4 x 6)	1				
26	5020-2	Fuel Filter, In Tank	1				
27	8046-3	Fuel Tank, 4.7 Gallon, Diesel	1				
28	7082-1	Fuel Tank Cap, Diesel	*				
29	5083-1	Bushing, Rubber	*				
30	7046-1	Fuel Return Tube	1				

ENGINE GROUP

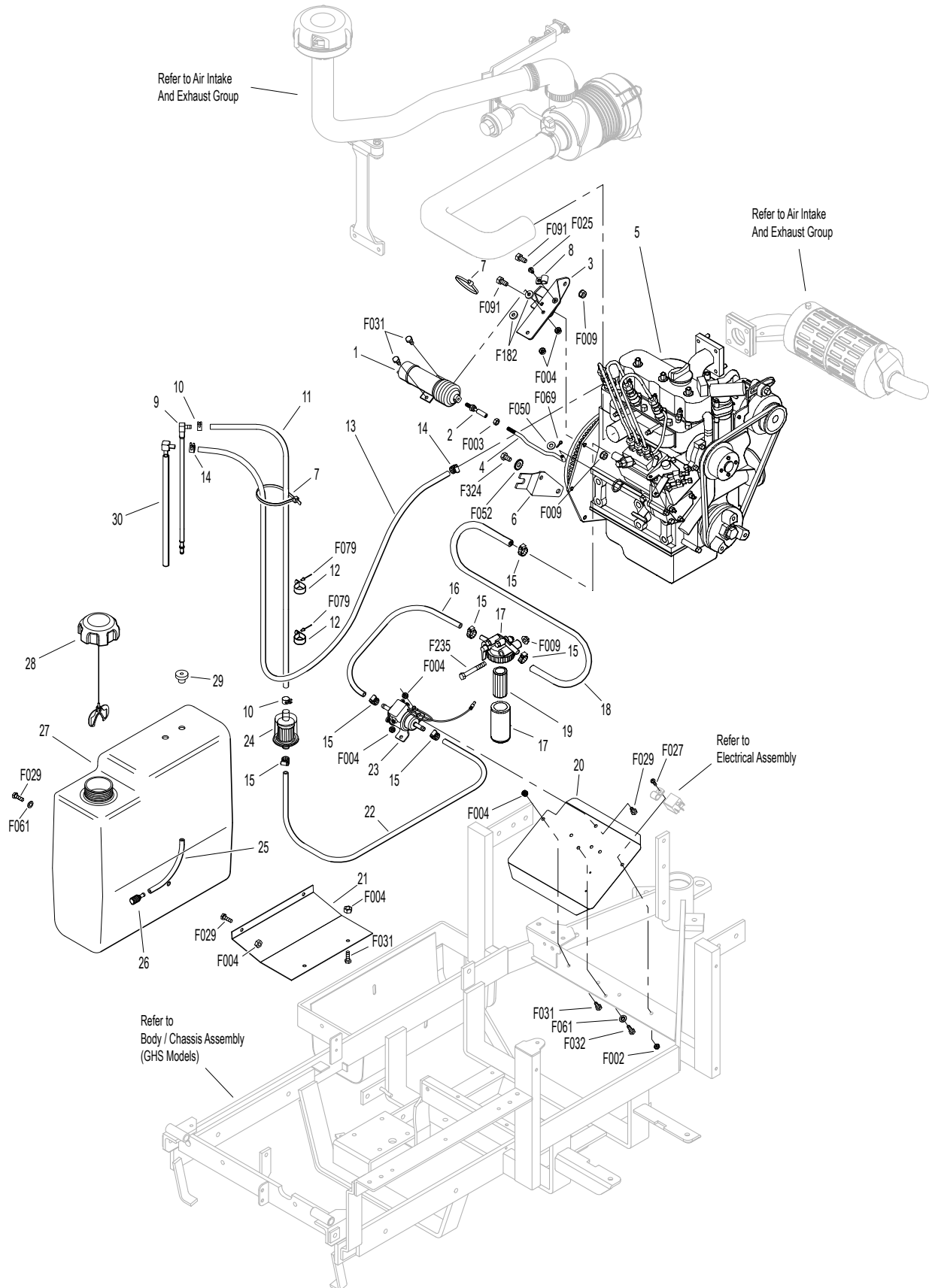

Beginning S/N 124860
 Effective Date 10-04-13
 Use only genuine **Walker**® replacement parts.

AIR INTAKE AND EXHAUST GROUP

ITEM NO.	PART NO.	DESCRIPTION	NO. REQ'D	ITEM NO.	PART NO.	DESCRIPTION	NO. REQ'D
Precleaner Assembly				Fasteners			
1	7026-2	Remote Precleaner (Includes Item # 2)	1	F002		10-24 Keps Nut	2
2	7840-5	Hose Clamp (1-1/2 to 2)	4	F009		5/16-18 Whiz Locknut	11*
3	7028-5	Precleaner Tube, 1-3/4 / GHS	1	F012		3/8-16 Keps Nut	3**
4	7440	Shock Mount (1.0 OD x 3/4)	3	F025		10-24 x 3/8 PPHMS	2
5	7028-20	Rear Precleaner Mount	1	F038		3/8-16 x 1 Hex Bolt	3**
6	7032	Elbow, Precleaner	1	F091		5/16-18 x 5/8 Hex Bolt	2
7	5088-8	Air Cleaner Assembly (Includes Items # 9-13, 16 & 17)	*	F217		7/16-14 Hex Nut	4
8	5088-1	Air Cleaner Band	1	F218		7/16 Split Lock Washer	4
9	5090-3	Safety Filter Insert	1	F219		7/16-14 x 1-1/4 Hex Bolt (GHS Models use only 3)	4
10	5090-1	Air Cleaner Cartridge	1	F226		5/16-18 x 7/8 Hex Bolt	1
11	5088-5	Air Cleaner Draw Latch	2	F239		7/16-14 x 1-1/2 Hex Bolt	1***
12	5088-11	Air Cleaner Cap	1	F249		M10 Split Lock Washer	8
13	5090-2	Vacuator Valve	1	F253		M8 x 1.25 x 35 Bolt, GR 8	3
14	7016	Air Intake Hose	1	F255		5/16-18 x 1-1/2 Hex Bolt	2*
15	7840	Hose Clamp (1-1/4 to 1-3/4)	1	F311		M10 x 1.25 x 20 Hex Bolt	8
16	5091-9	Street Elbow 90° (1/8 x 1/8)	1	F327		M8 x 1.25 x 45 GR 8 Hex Bolt	1
17	5091-0	1/8 Pipe Thread Male W/Barb	1	F482		8-32 Nylock Nut	2
18	M258	Vacuum Hose (7")	1 ^Δ	F483		8-32 x 3/4 PPHMS	2
19	5091-13	Air Flow Indicator W/Bracket (Vacuum 20" H2O)	1				
20	7031-2	Tube Support Arm	1				
Exhaust Assembly							
21	7437-1	Exhaust Manifold Shield	1				
22	NS	Spring Washer (04512-50080 Kubota)	4				
23	7437-6	Engine Brace (Includes Items # 20, F002 & F025)	1				
24	NS	Muffler (15262-12110 Kubota)	1				
25	NS	Muffler Gasket (15371-12370 Kubota)	2				
26	7034	Spacer, Muffler	1				
27	7354	Motor Mount	2				
28	7306-15	Water Temperature Sender	1				
29	7306-12	Temperature Sender Adapter	1				
30	7306-13	Oil Pressure Switch	1				
31	7023	Oil Filter (15841-32439 Kubota)	1				
32	7047-2	Manifold Heat Shield	1				
33	7013-2	Tail Pipe	1				

* Two (2) F009 and two (2) F255 fasteners are reused from Clutch Lever Assembly. Refer to **MAIN COMPONENT POWER TRANSMISSION (GHS OR SD MODELS)**, Pages 10 or 12.

** One (1) F012 and one (1) F038 fastener are reused from Rear Bumper Assembly. Refer to **BODY / CHASSIS ASSEMBLY (GHS MODELS)**, Page 4.

*** GHS Models Only

^Δ **Required hose specifications:**
M258 - 7/64" ID automotive vacuum hose

NOTE: Decals for this assembly are not shown here. Refer to **TRACTOR DECALS**, Page 2 for Decal listing and placement information.

AIR INTAKE AND EXHAUST GROUP

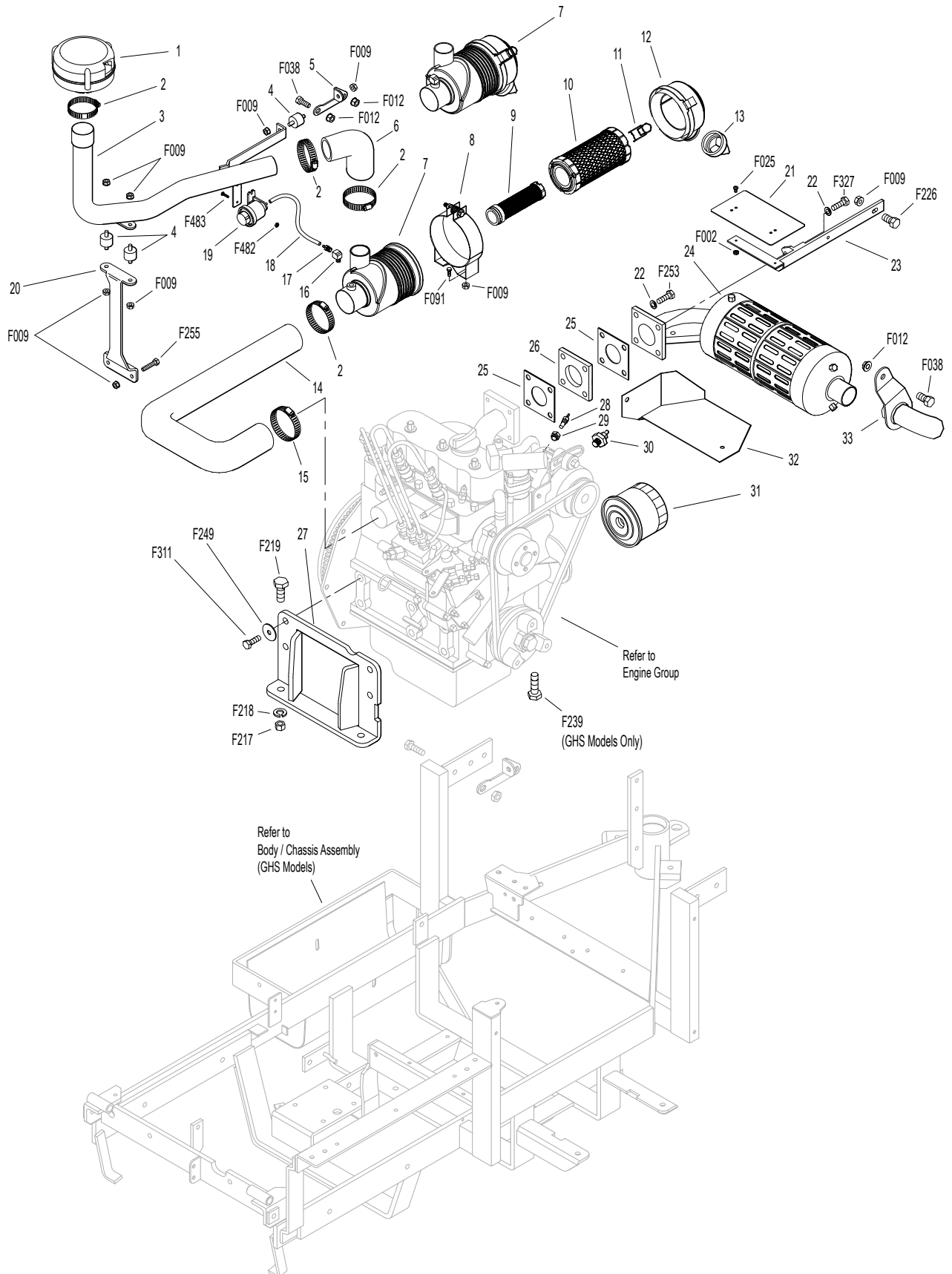

Beginning S/N 124860
 Effective Date 10-04-13
 Use only genuine **Walker**® replacement parts.

RADIATOR GROUP

ITEM NO.	PART NO.	DESCRIPTION	NO. REQ'D	ITEM NO.	PART NO.	DESCRIPTION	NO. REQ'D
Radiator Assembly				Fasteners			
1	7840-4	Hose Clamp (3/4 to 1-1/2)	1	F004		1/4-20 Keps Nut	6
2	7017-3	Upper Radiator Hose	1	F014		3/8-16 ESNA Nut	2
3	7840-3	Hose Clamp (1/2 to 1-1/4)	3	F029		1/4-20 x 1/2 Hex Bolt	5
4	7427-21	Fan Mount Tab, LH	2	F031		1/4-20 x 5/8 Hex Bolt	7
5	7429-6	Radiator Cooling Fan	1	F061		1/4 Internal Star Lock Washer	7
6	7427-5	Radiator Fan Shroud	1	F073		1/4 x 1.5 Fender Washer	2
7	NS	Recovery Tank Hose Clamp (15501-72470 Kubota)	2	F089		Belleville Washer, SS	*
8	M110	Recovery Tank Hose	1**	F090		1/4-20 x 2-1/2 Hex Bolt	2
9	NS	Coolant Recovery Tank and Hose (19059-72090 Kubota)	1	F129		10-24 x 1/2 PTHMS	4
10	5975-3	Cable Tie (50# x 7")	2	F143		10-32 x 1/4 Whiz Lock Bolt	*
11	7427-9	Radiator Cap	*	F222		Thrust Washer	*
12	7427	Radiator	1	F237		Spring Ring	*
13	7431-1	Radiator Channel Seal (1/4 x 1/2 x 13.5)	2	F254		Fender Washer	*
14	7435	Radiator Brace	1				
15	7432	Shock Mount (1.00 OD x .75)	1				
16	7425-3	Radiator Screen	1				
17	7426	Screen Channel	2				
18	7429-7	Fan Blade Replacement (Includes Items # F089, F143, F222, F237 & F254)	*				
19	7430	Radiator Guard	1				
20	5841	Retainer Washer (3/8 x 1-1/4)	2				
21	7434	Washer (3/8 x 1-1/4 x 1/4)	4				
22	7427-7	Debris Shield, Shroud	1				
23	7427-22	Fan Mount Tab, RH	2				
24	7017-2	Lower Radiator Hose	1				

* Service Part Only

** **Required hose specifications:**
M110 - 7/32" ID EDM Hose

NOTE: Decals for this assembly are not shown here. Refer to **TRACTOR DECALS**, Page 2 for Decal listing and placement information.

HYDROSTATIC GROUND DRIVE ASSEMBLIES

ITEM NO.	PART NO.	DESCRIPTION	NO. REQ'D	ITEM NO.	PART NO.	DESCRIPTION	NO. REQ'D
Transmission Lockout Assembly				Transmission Repair Parts			
1	5028-3	Transmission Lockout Assembly (Includes Items # 2-5, F023, F027 & F081)	*	28	5025-5	Input Shaft	*
2	5847	Plastic Tip	2	29	5025-8	Bearing, Input Shaft	*
3	5057	Lockout Cam (Includes Item # F081)	2	30	5025-7	Snap Ring	*
4	5028-5	Lockout Lever	2	31	5025-2	Seal, Input Shaft	*
5	5027-5	Lockout Mount	1**	32	5022	Reservoir to Casting Gasket	*
Ground Drive Assemblies				33	5024	Reservoir Cap and Gasket	*
6	6209-3	Bridge Assembly	1	34	5023	Transmission Reservoir Kit	*
7	5832	Cable Clamp (1/2)	1	35	5023-1	Rubber Bladder	*
8	7394-7	Throttle Cable Mount Bracket	1	36	5025-6	O-Ring & Plug Assembly	*
9	6243-1	Hydro Fan, CW	1	37	5025-3	Seal, Control Shaft	*
10	5025	Hydrostatic Drive, CCW (700-052)	1	Fasteners			
11	6206-1	Air Vent Valve	*	F012	3/8-16 Keps Nut		2
12	6200-9	Gear Axle Drive Assembly (Includes Items # 11 & 13)	2	F023	10-24 ESNA Nut		2
13	6207-12	Pipe Plug (1/4 NPTF)	4	F026	10-24 x 1/2 PPHMS		1
14	5126	Cable Retainer (Uses existing bolt on Gear Axle Drive Assembly)	1	F027	10-24 x 5/8 PPHMS		2
15	6233-1	Pinion Gear	2	F036	1/4-20 x 1/2 SBH Screw		2
16	6234	Spacer, Pinion Gear	2	F038	3/8-16 x 1 Hex Bolt		4
17	6201	O-Ring Seal	2	F040	3/8-16 x 1-1/2 Hex Bolt		4
18	7244	Hydro Pulley (3-7/8/MV) (Includes Items # F064 & F359)	2	F043	3/8-16 x 3 Hex Bolt		7
19	6243-2	Hydro Fan, CCW	1	F053	7/16 Internal Star Lock Washer		4
20	5026	Hydrostatic Drive, CW (700-051)	1	F063	3/8 Internal Star Lock Washer		16
Deck Support Arm Assemblies				F064	1/8 x 1/2 Woodruff Key (#3)		4
21	6430-10	Outboard Mount, LH	1	F081	A/A45D Aluminum Pop Rivet		2
22	6431-1	Deck Support Arm, LH (Includes Item # 26)	1	F160	External Snap Ring (.669 Shaft)		2
23	5775-2	Hitch Pin (#6)	2	F178	1/4 x 1 Fender Washer		2
24	6431-2	Deck Support Arm, RH (Includes Item # 26)	1	F194	7/16 x 1-1/4 x 1/8 Washer		2
25	6430-9	Outboard Mount, RH	1	F200	7/16-20 x 3 Grade 8 Bolt		2
26	5830	Grease Fitting	2	F244	7/16-20 x 3/4 Hex Bolt		2
27	6840-1	Support Arm Bushing (2-1/16)	2	F262	3/8-16 x 4 Hex Bolt All Thread		2
				F359	5/16-18 x 5/16 Set Screw (Unbrako Knurl Point)		4
				* Service Part Only			
				** Part not used on Jackshaft side of tractor.			

HYDROSTATIC GROUND DRIVE ASSEMBLIES

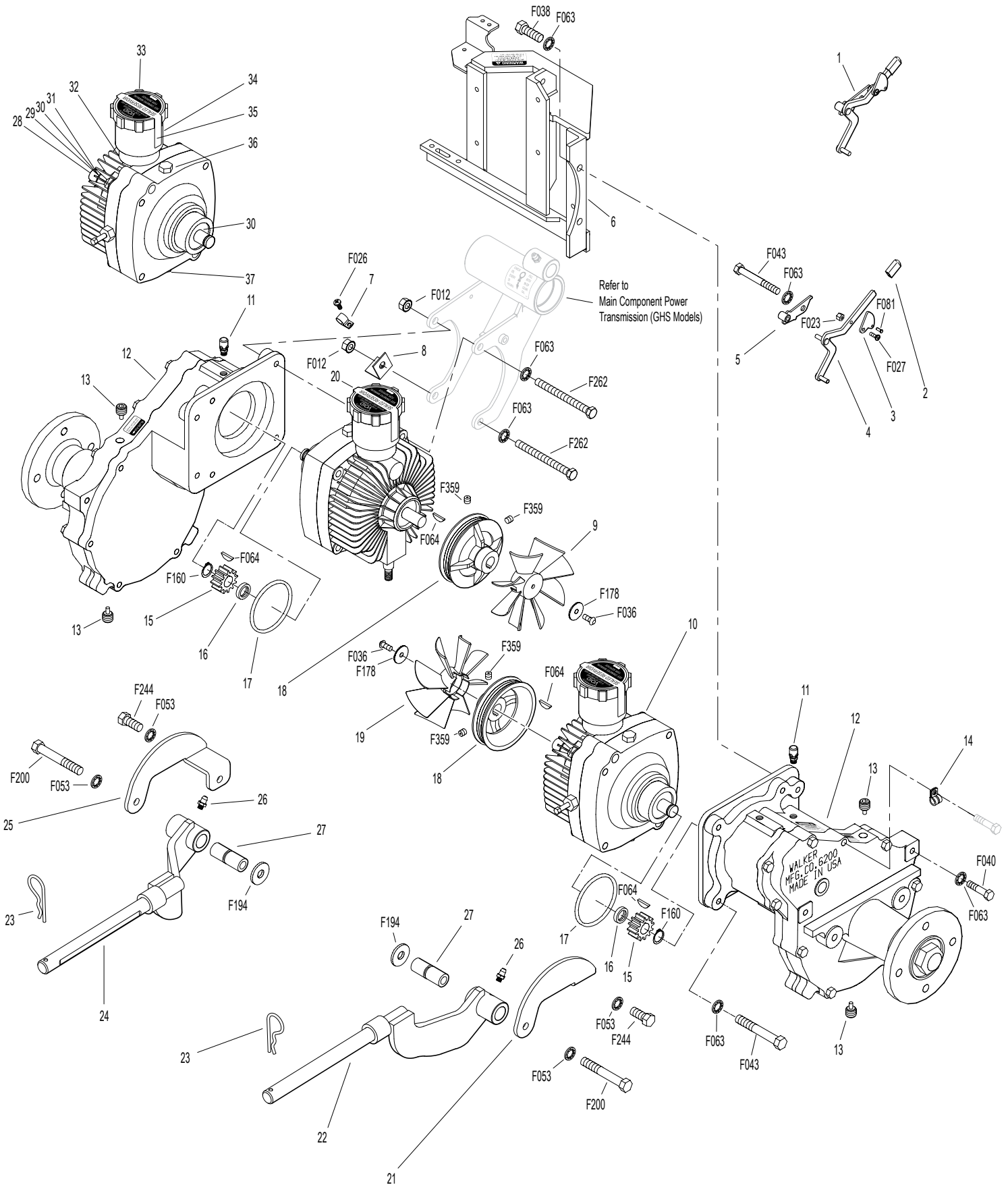

Beginning S/N 124860
 Effective Date 10-04-13
 Use only genuine Walker® replacement parts.

STEERING CONTROL ASSEMBLIES

ITEM NO.	PART NO.	DESCRIPTION	NO. REQ'D	ITEM NO.	PART NO.	DESCRIPTION	NO. REQ'D	
Transmission Spring Assemblies				30	5470-1	Speed Control Stop	1	
1	6201-2	Shock Mount Gear Drive, RH	1	31	5450-10	Steering Lever Assembly, RH / Adjustable (Includes Items # 9, 10, 16, F360 & F489)	1	
2	5146	10mm Ball Stud	4		5450-7	Steering Lever Arm, RH / Adjustable	*	
3	6199-3	Steering Lever Dampener Assembly	2	32	5862	FSC Knob	1	
4	6201-1	Shock Mount Gear Drive, LH	1	33	7170	FSC Lever Assembly (Includes Item # 16)	1	
5	5214-2	Ball Joint (5/16-24) Nylon Lined	2	34	5975-3	Cable Tie (50# x 7")	1	
6	6212-1	Transmission Control Arm, LH	1	Fasteners				
7	5213-3	Control Rod (6")	1		F003	1/4-28 Hex Nut	1	
8	5665-1	Compression Spring (2-1/2)	2		F004	1/4-20 Keps Nut	6	
9	5463-2	Steering Lever Actuator	2		F007	5/16-18 Jam Nut	1	
10	7201-2	Fiberglide Bearing 1/2"	2		F008	5/16-24 Keps Nut	2	
11	5213-4	Control Rod (14-3/4")	1		F009	5/16-18 Whiz Locknut	5	
12	5212	Transmission Control Arm, RH	1		F010	5/16-24 ESNA Nut	2	
Steering Lever & FSC Assemblies						F024	5/16-24 Jam Nut	2
13	5173	FSC Actuator Rod	1		F029	1/4-20 x 1/2 Hex Bolt	2	
14	5172	Bearing, Delrin (.255 ID x .379 OD x .250)	1		F032	1/4-20 x 3/4 Hex Bolt	4	
15	5142-2	FSC Actuator Cam	1		F034	5/16-18 x 3/4 Hex Bolt	1	
16	5830	Grease Fitting	6		F050	1/4 SAE Washer	3	
17	5141	FSC Friction Washer (1-1/2 x 3/8 x 1/16)	2		F051	3/8 SAE Washer	2	
18	5140-15	FSC Friction Body (Includes Item # 16)	1		F064	1/8 x 1/2 Woodruff Key (#3)	2	
19	5142-7	FSC Key W/Stop	1		F068	1/8 x 1 Cotter Pin	1	
	5140-13	FSC Control Assembly (Includes Items # 15-19, F192 & F193)	*		F069	3/32 x 1/2 Cotter Pin	1	
20	5850-2	Handle Grip, Foam (5-1/2)	2		F093	5/16-18 x 1 Hex Bolt	1	
21	5223	Extension Spring (1/4 x 5-1/2)	2		F183	.312 x .700 x .074 Washer	2	
22	5450	D-Clip	2		F186	5/64 x 1/2 Cotter Pin	1	
23	5391-3	Steering Lever Support	1		F188	1/4-20 Self-Locking Nut	4	
24	5217	Pivot Pin, Steering Lever	1		F192	3/8-24 Self-Locking Nut	1	
25	5451-10	Steering Lever Assembly, LH / Adjustable (Includes Items # 9, 10, 16, F360 & F489)	1		F193	3/8 Belleville Spring Washer	3	
	5451-7	Steering Lever Arm, LH / Adjustable	*		F198	.250 x .625 x .040 Washer, SS	2	
26	5453-10	Steering Lever Handle, Adjustable (Includes Items # 20 & F345)	2		F353	3/8-16 ESNA LP Nut	2	
27	5219	Extension Spring (3/4 x 6-3/4)	1		F345	1/4-20 x .770 Knurled Bolt	4	
28	5280	Clevis (1/4")	1		F360	1/4-20 x 3/8 Hex Bolt	2	
29	5281-5	Clevis Pin (1/4 x 0.80)	1		F401	.504 x .751 x .030 Washer	1	
					F489	Washer 1/4 x 7/8 x .090	2	
				*	Service Part Only			

THROTTLE CONTROL ASSEMBLY

ITEM NO.	PART NO.	DESCRIPTION	NO. REQ'D	ITEM NO.	PART NO.	DESCRIPTION	NO. REQ'D
Throttle Control Assembly				Fasteners			
1	5833	Cable Clamp (1/4)	2		F002	10-24 Keps Nut	4
2	7220	Throttle Cable	1		F005	1/4-20 ESNA Nut	1
3	NS	10-32 Jam Nut	2		F025	10-24 x 3/8 PPHMS	4
4	5150	Ball Joint (10-32)	2		F201	1/4 Belleville Spring Washer	2
5	5108-7	Control Lock Tab	1		F232	10-32 Keps Nut	2
6	5108-10	Friction Washer (.125)	1				
7	5108-1	Control Lever, Throttle	1	*		Service Part Only	
8	5108-5	Throttle Control Knob, Red	1				
9	5108-11	Friction Washer (.062)	1				
10	5108-8	Control Bracket	1				
11	7108	Control Assembly (Includes Items # 5-7, 9, 10 & F201)	*				
12	7112	Throttle Control and Cable Assembly (Complete Control and Cable Assembly) (Includes Items # 2, 4, 8, 11 & F232)	*				

NOTE: Decals for this assembly are not shown here. Refer to **TRACTOR DECALS**, Page 2 for Decal listing and placement information.

THROTTLE CONTROL ASSEMBLY

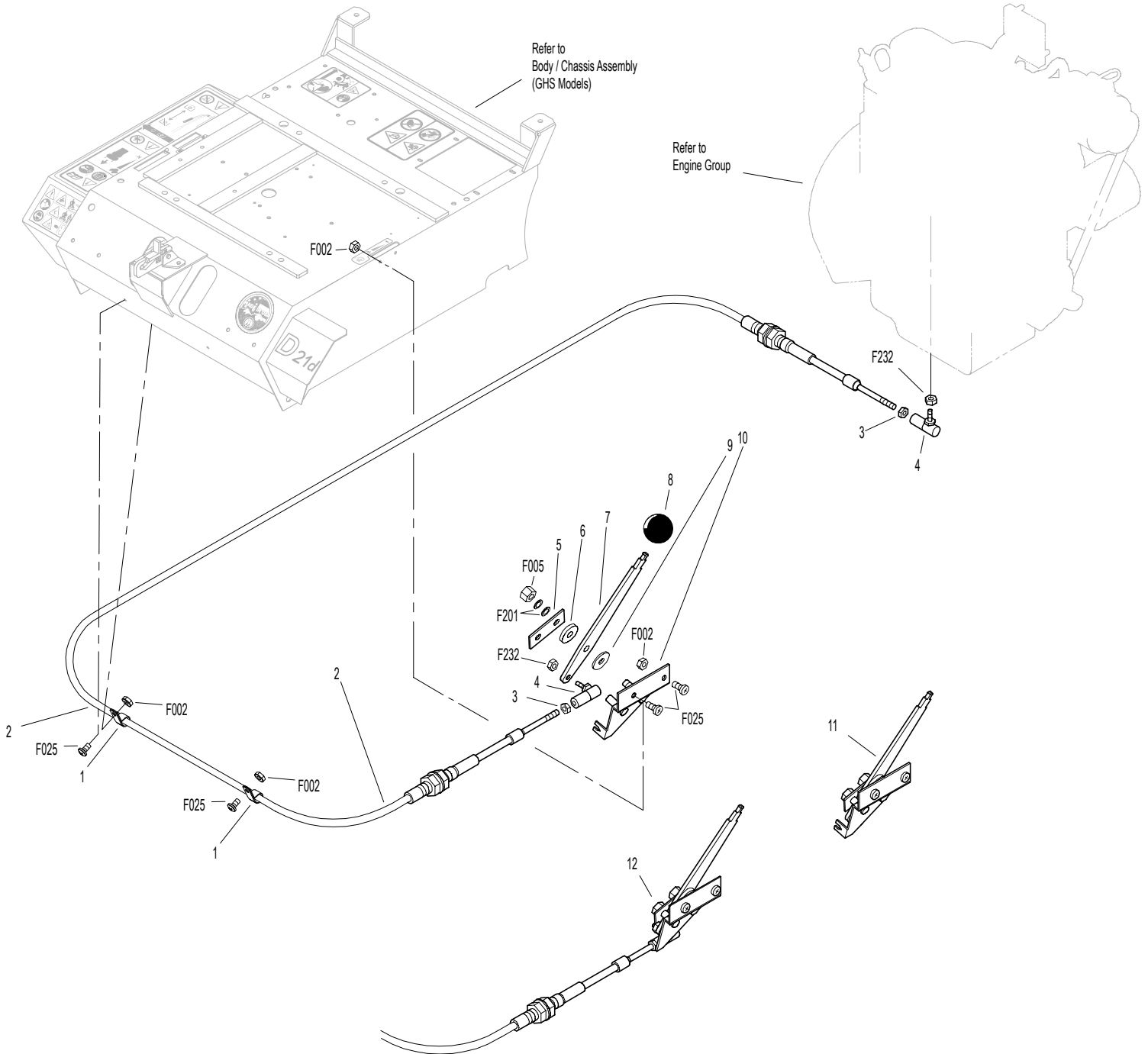

Beginning S/N 124860
Effective Date 10-04-13
Use only genuine Walker® replacement parts.

PARKING BRAKE ASSEMBLY

ITEM NO.	PART NO.	DESCRIPTION	NO. REQ'D	ITEM NO.	PART NO.	DESCRIPTION	NO. REQ'D
Parking Brake Assembly				Fasteners			
1	7406-1	Handle Grip, Red	1	F002		10-24 Keps Nut	2
2	7406-8	Parking Brake Lever (4-1/4)	1	F003		1/4-28 Hex Nut	1
3	7406-2	Lever Mount	1	F004		1/4-20 Keps Nut	4
4	5830	Grease Fitting	1	F025		10-24 x 3/8 PPHMS	2
5	7407	Clevis Pin (3/16 x 1/2)	2	F029		1/4-20 x 1/2 Hex Bolt	3
6	7404-6	Brake Actuator Arm	2	F032		1/4-20 x 3/4 Hex Bolt	1
7	7405	Pin, Transmission Lock	2	F054		AN960616 Washer	2
8	7402	Clevis	2	F072		1/4 "E" Retainer Ring	2
9	7408	Compression Spring (1/2 x 3/4)	2	F086		#10 SAE Washer	4
10	7415	Rubber Dust Shield (5/8 x 3/8 x 1/32)	2	F109		1/8 x 5/8 Roll Pin	2
11	5567-3	O-Ring Seal (1/4 x 3/8)	4	F111		1/8 x 3/4 Cotter Pin	1
12	7403	Plunger Bushing, Gear Axle	2	F112		5/8 x 1-1/4 x .03 Washer	2
13	7404-7	Brake Actuator Mount	2	F127		1/16 x 1/2 Cotter Pin	4
14	7412	Clevis Pin (3/16 x 5/8)	2	F261		AN960616L Washer	5
15	5833	Cable Clamp (1/4)	2	F287		1/4-28 Keps Nut	1
16	7410	Brake Control Cable, LH (25.5")	1				
17	7409	Brake Control Cable, RH (20.5")	1				
18	7401-3	Cable Mount Bracket	1				
19	7401-1	Cable Pull Rod	1				
20	5552	Ball Joint (1/4-28)	1				

PARKING BRAKE ASSEMBLY

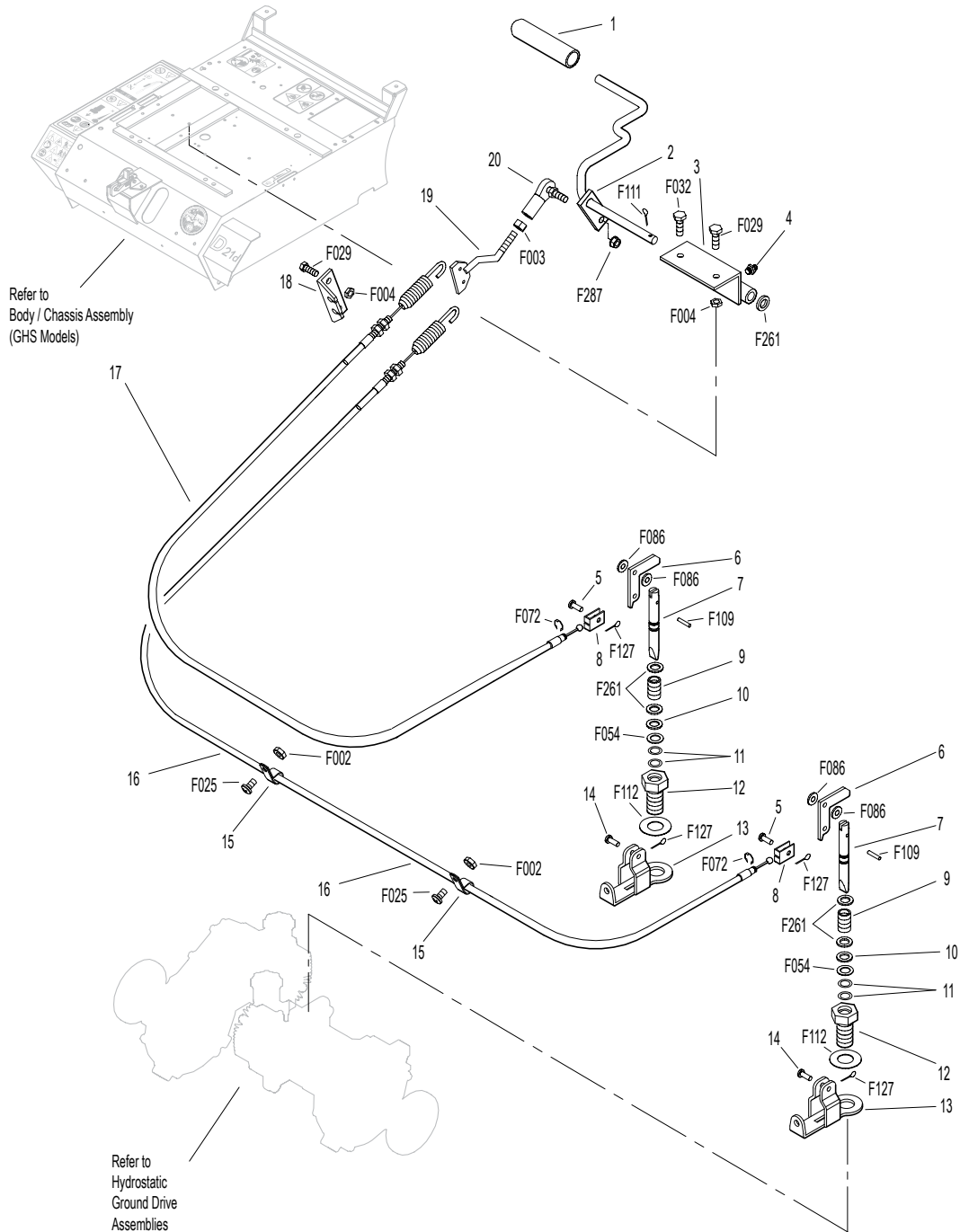

GHS GROUP

ITEM NO.	PART NO.	DESCRIPTION	NO. REQ'D	ITEM NO.	PART NO.	DESCRIPTION	NO. REQ'D
Delivery Chute Assembly				Fasteners			
1	5515-2	Elbow Delivery Spout	1	F002		10-24 Keps Nut	6
2	5592-13	Backing Plate, Grass-Pak® Switch	1	F004		1/4-20 Keps Nut	3
3	5578	Rear Clip, Chute Mount	1	F009		5/16-18 Whiz Locknut	7
4	5577	Side Clip, Chute Mount	2	F012		3/8-16 Keps Nut	3
5	8511-1	Delivery Chute W/Clips / 10.0 (Includes Items # 3, 4, 6, F362 & F411)	1	F026		10-24 x 1/2 PPHMS	2
6	5578-10	Front Clip, Chute Mount	1	F029		1/4-20 x 1/2 Hex Bolt	3
7	7530-4	Body Chute (10.5 Blower)	1	F034		5/16-18 x 3/4 Hex Bolt	1
Blower Belt Tightener Assembly				F039		3/8-16 x 1-1/4 Hex Bolt	1
8	7238-6	Blower Drive Pulley (Includes Items # F075, F114 & F231)	1	F040		3/8-16 x 1-1/2 Hex Bolt	1
9	7234-2	Blower Belt (Micro-V)	1	F042		3/8-16 x 2-1/4 Hex Bolt	1
10	7239-1	Blower Pulley (Micro-V) (Includes Items # F067, F075 & F114)	1	F050		1/4 SAE Washer	1
11	7364-2	Torsion Spring	1	F054		AN960616 Washer	1
12	7201-3	Fiberglide Bearing	2	F067		3/16 x 3/16 x 1 Key	1
13	5830-3	Grease Fitting (45 Deg.)	1	F075		5/16-18 x 1/2 SQH Set Screw	2
14	7364-1	Blower Belt Tightener Arm	1	F079		A/A66D Aluminum Pop Rivet	6
15	7201-4	Inner Race (1-1/2)	1	F090		1/4-20 x 2-1/2 Hex Bolt	1
16	5841	Retainer Washer (3/8 x 1-1/4)	1	F114		5/16-18 x 5/8 SQH Set Screw	2
17	5245	Idler Pulley (3")	1	F128		10-24 x 3/8 PTHMS	4
Blower Assembly				F131		5/16-18 x 1/2 Hex Bolt	3
18	8539	Starter Relay Mount	1	F132		1/4-20 x 2-3/4 Hex Bolt	1
19	5268	Bearing W/Collar (3/4)	2	F168		5/16 Split Lock Washer	3
20	7544	Blower Assembly (10.5") (Includes Items # 19, 21-25, F004, F009, F029, F050, F131, F168 & F426)	1	F217		7/16-14 Hex Nut	1
21	7543-3	Blower Housing (10.5)	1	F218		7/16 Split Lock Washer	1
22	7545-2	Blower Output Shaft (10.5)	1	F231		1/4 x 3/4 Woodruff Key (# 806)	1
23	7545	Blower Wheel (10.5")	1	F281		7/16-14 x 1-3/4 Hex Bolt	1
24	7543-1	Blower Faceplate (10.5)	1	F362		A/A62D Alum. Pop Rivet (3/16D x 13/32L)	2
25	7526	Intake Tube (10.5 Blower)	1	F411		3/16 Bulbex Rivet	6
26	7528-2	Skid Bar (10.5" Blower)	1	F426		1/4-20 x 1/2 Carriage Bolt	1
27	5595-2	Intake Cover/GHS	**	* Service Part Only ** Plugs Blower when GHS is not in use. Furnished only with Mulching Decks, SD Decks used on a GHS Tractor, Rotary Broom Attachment and Snowblower Attachment. Use of this part may be replaced by installing Blower Lockout Kit (P/N 7541).			
28	7833	Cable Clamp (7/8 x 1/4)	1				

NOTE: Refer to **ELECTRICAL CONNECTORS**, Page 40 for identification of all Electrical Wiring Service Parts.

GHS GROUP

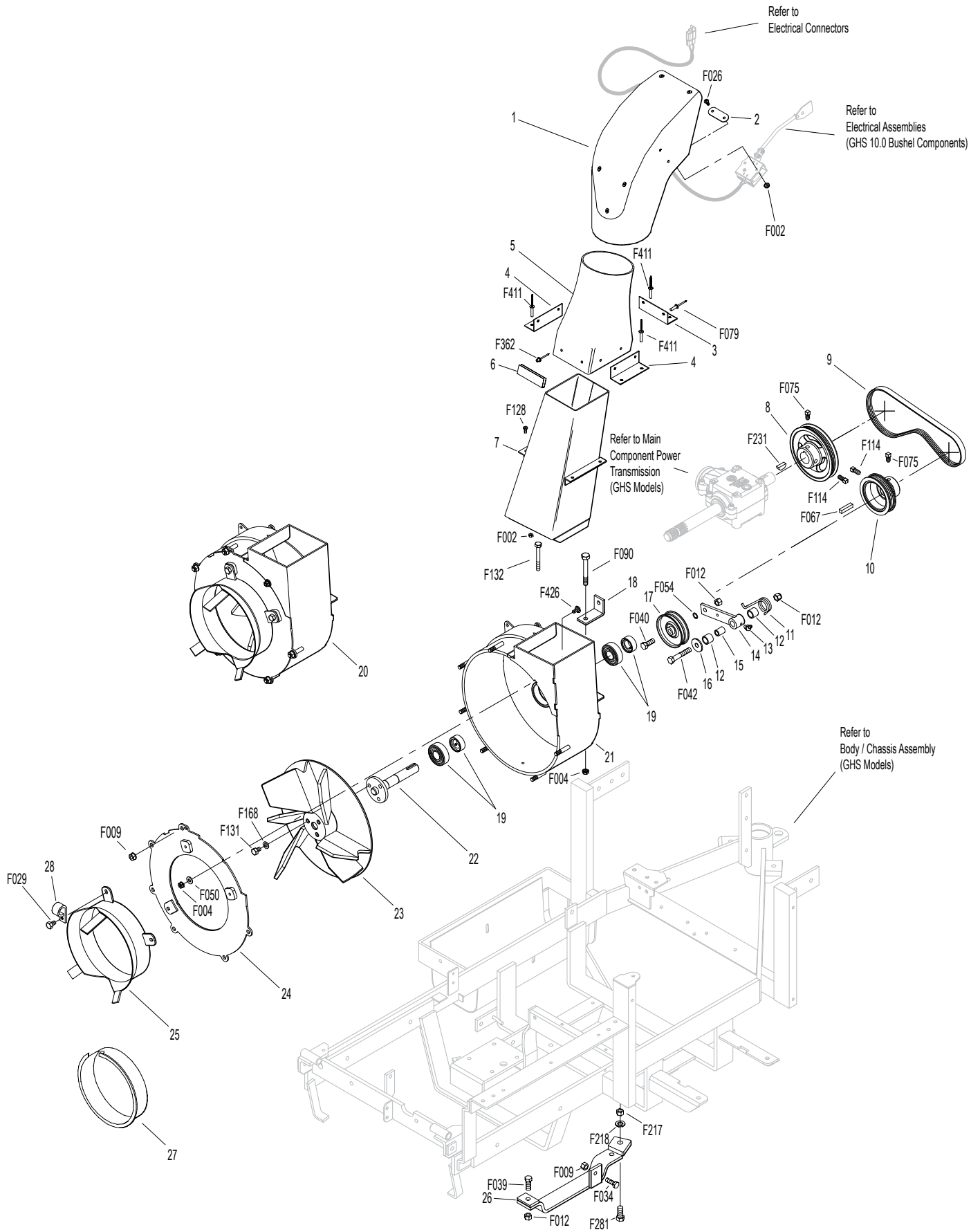

Beginning S/N 124860
 Effective Date 10-04-13
 Use only genuine Walker® replacement parts.

GHS POWERFIL® ASSEMBLY (10.0)

ITEM NO.	PART NO.	DESCRIPTION	NO. REQ'D	ITEM NO.	PART NO.	DESCRIPTION	NO. REQ'D
10.0 GHS Powerfil® Assembly				Fasteners			
1	5551-3	Bearing Cap, Powerfil®	1	F002		10-24 Keps Nut	10
2	5551-1	Pivot Bearing (#S3PP)	2	F003		1/4-28 Hex Nut	3
3	5518-2	Pivot, Delivery Spout	1	F026		10-24 x 1/2 PPHMS	1
4	5517-2	Pivot Mount	1	F037		10-24 x 5/8 PTH Screw	2
5	5552	Ball Joint (1/4-28)	2	F054		AN960616 Washer	1
6	5558-1	Powerfil® Push Rod	1	F085		3/16 Rivet Backup Washer	1
7	5553-3	Bushing, Powerfil® Actuator	4	F101		10-24 x 1-1/4 SHC Screw	1
8	5553-1	Compression Spring (1/2 x 2)	2	F109		1/8 x 5/8 Roll Pin	1
9	5558-2	Powerfil® Actuator Rod	1	F129		10-24 x 1/2 PTHMS	6
	5549	Actuator Rod Assembly (Includes Items # 5-9 & F003)	*	F261		AN960616L Washer	1
10	5519-3	Motor Mount Nut (5/8-24)	*	F287		1/4-28 Keps Nut	1
11	5554	Actuator Arm	1	* Service Part Only			
12	5519-2	Motor Mount Washer	*				
13	5976-2	Grommet (3/16 x 3/4)	1				
14	5519-5	Actuator Motor (12V) (Includes Items # 11 & 12)	1				

GHS POWERFIL® ASSEMBLY (10.0)

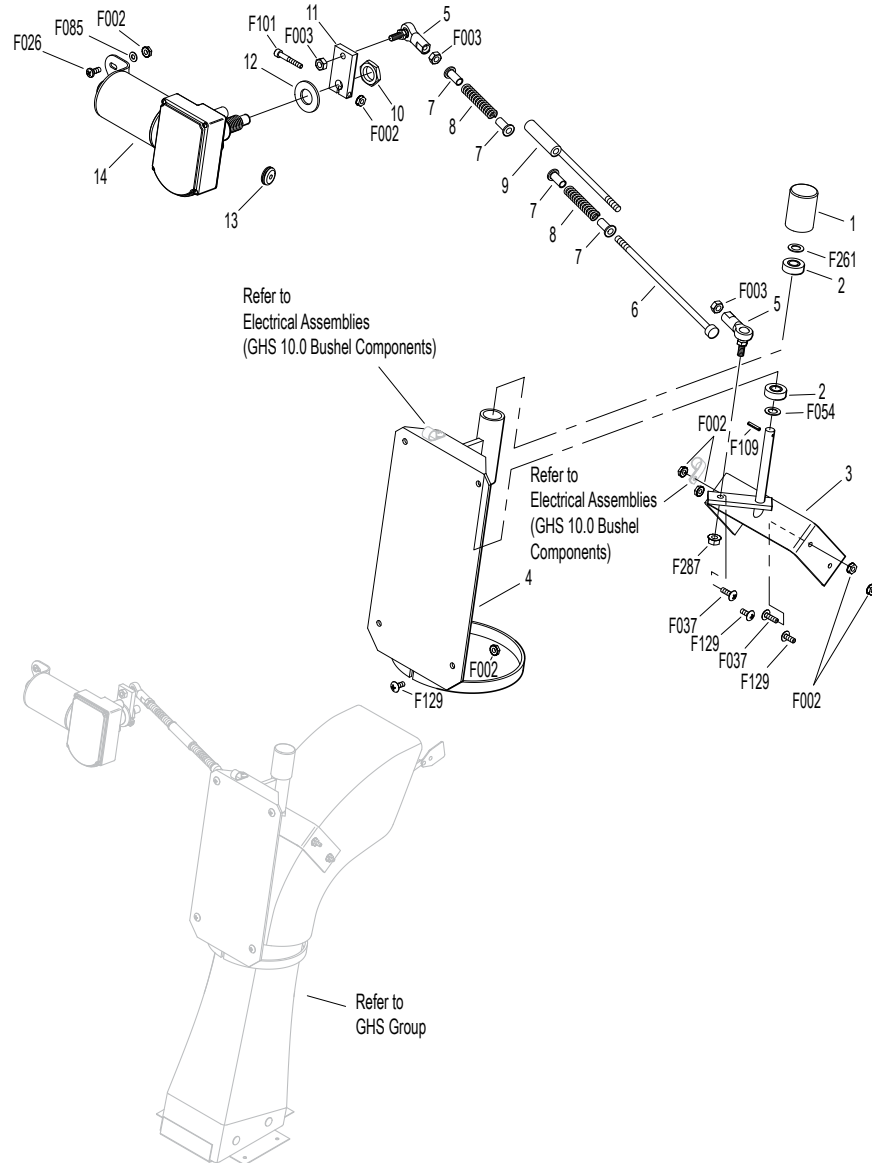

GHS 10.0 BUSHEL CATCHER ASSEMBLY

ITEM NO.	PART NO.	DESCRIPTION	NO. REQ'D	ITEM NO.	PART NO.	DESCRIPTION	NO. REQ'D
Upper Baffle Screen Assembly (Removable)				45	8608-10	Box Support, Gas Spring	2
1	7512-2	Removable Screen (3/16 Hole) (Includes Items # 2, 5, F025 & F190)	1**	46	7532-1	Handle, Catcher Lift	2
2	7506	Knob / Threaded Insert (10-24)	2	47	5977	Grommet (1/2 x 7/8 x 1/16)	2
3	8606-3	Channel Top, LH	1	48	8117	Wire Harness Channel	1
4	8606-2	Channel Bottom	2	49	8602-3	10.0 Catcher W/O Powerfil®, Gray (Includes Door)	*
5	7856-1	Edge Molding (26")	1		8602-4	10.0 Catcher W/Powerfil®, Gray (Includes Door)	*
6	7507	Screen Seal (27-1/2)	1		8610-5	10.0 Bushel Catcher Box, Gray	*
7	7505	Mustache Spring	2	50	8607-9	Powerfil® Cover Plate	1
8	8606	C-Channel (10.0)	1	51	8155-2	Gas Spring Cover, RH	1
	8606-20	C-Channel With Spring (10.0) (Includes Items # 7, 8 & F340)	*	52	8608-8	Hinge Plate, RH	1
9	8606-4	Channel Top, RH	1	53	8608-9	Torsion Bar	1
10.0 Exhaust Deflector Door Assembly				5598-2 Optional Dump Bag (Not Shown)			
10	8607-6	Upper Seal Support	1	May be ordered as an option. Contact your Walker dealer.			
11	8607-5	Upper Door Seal	1	Fasteners			
12	8607-11	Backup Plate	1	F002	10-24 Keps Nut		29
13	8512-3	10.0 Catcher Box Door (Includes Items # 10-14, 16, 17, F085, F330 & F411)	1	F004	1/4-20 Keps Nut		25
14	5583	Handle	1	F009	5/16-18 Whiz Locknut		4
15	8607-1	Door Mount, LH	1	F020	5/16-18 ESNA Nut		2
16	8607-12	Upper Door Stiffener	1	F024	5/16-24 Jam Nut		4
17	8607-7	Lower Door Stiffener	1	F025	10-24 x 3/8 PPHMS		4
18	8607-8	Door Guide	1	F026	10-24 x 1/2 PPHMS		2
19	8607-2	Door Mount, RH	1	F027	10-24 x 5/8 PPHMS		8
GHS 10.0 Bushel Catcher Assembly				F029	1/4-20 x 1/2 Hex Bolt		10
20	8608-5	Center Strap	1	F049	5/16 SAE Washer		8
21	8608-3	Upper Frame Doubler	2	F050	1/4 SAE Washer		2
22	8608-1	Outside Box Strap, LH	2	F068	1/8 x 1 Cotter Pin		2
23	8608-2	Lower Frame Doubler	2	F079	A/A66D Aluminum Pop Rivet		14
24	8608-4	Center Frame Doubler	1	F085	3/16 Rivet Backup Washer		13
25	8608-11	Catcher Door Finger	1	F094	8-32 x 1/2 PTHMS		6
26	8608-6	Catcher Mount	1	F129	10-24 x 1/2 PTHMS		17
27	8610-4	Catcher Dump Flap W/Plate 10.0	1	F190	#10 Internal Star Lock Washer		2
28	8610-3	Backing Plate, Dump Flap	1	F195	1/4-20 x 3/4 PPHMS, SS		4
29	7584	Reinforcing Strap	1	F196	1/4-20 x 1 PPHMS, SS		4
30	5103-5	Pivot Bushing Inner	2	F208	5/16-18 x 2-1/4 Hex Bolt		2
31	5801-3	Decal Plate, Round (Set of 2)	1	F230	1/4-20 x 1-1/4 PPHMS, SS		4
32	7620-3	Pivot Bushing (1/2 x 9/16)	2	F242	1/4-20 x 7/8 PPHMS, SS		8
33	8608-7	Hinge Plate, LH	1	F330	3/16D x 21/32L Rivet, SS		9
34	5103-7	Outside Torsion Bushing	2	F340	Rivet, Aluminum		4
35	8607-4	Upper Arm	2	F351	Aluminum Pop Rivet		6
36	5214-12	Ball Joint (5/16-24)	4	F360	1/4-20 x 3/8 Hex Bolt		2
37	5155-12	5/16 Ball Stud	2	F390	1/4-20 x 7/8 Carriage Bolt		4
38	5155-4	Gas Spring	2	F411	3/16 Bulbex Rivet		10
39	5147	Spring Clip	4	F456	5/16-18 x 3/4 SBH Cap Screw, SS		4
40	8155-1	Gas Spring Cover, LH	1	F503	1/4-20 x 1-1/2 PPHMS, SS		1
41	8607-3	Lower Arm	2	F524	3/16 x 3/8 Aluminum Rivet, Black		6
42	5103-6	Pivot Bushing Outer	2	* Service Part Only			
43	5155-13	3/4 Ball Stud	2	** This screen can be replaced by P/N 7512-3 Removable Screen (3/4" holes) for improved air flow performance in wet conditions.			
44	5523-6	Gas Spring Plate	2				

Beginning S/N 124860

Effective Date 10-04-13

Use only genuine Walker® replacement parts.

INSTRUMENT PANEL ASSEMBLY

ITEM NO.	PART NO.	DESCRIPTION	NO. REQ'D	ITEM NO.	PART NO.	DESCRIPTION	NO. REQ'D
Instrument Panel Assembly				22	7307-16	Lining, Panel Box (1/8)	1
1	7307-2	Instrument Panel Cover (Optional)	**	23	6941-6	Relay Switch (30/40 Amp)	*
	7396-1	Instrument Panel Assembly (Includes Items # 2-4, 6-16, 25-27, F228, F250 & F251)	1	24	6941-7	Relay Mount	*
2	7307-7	Panel Frame	1	25	8536	Warning Horn	1
3	7307-8	Panel Faceplate W/Decal	1	26	6942	Relay Switch (30/40 Amp) NC (Includes Items # 23 & 24)	3
4	7386	Panel Gasket	1	27	7947-8	Jumper Wire	1
5	7960-6	Ignition Key (1 Set)	*	Fasteners			
6	7960-5	Ignition Switch (with Keys) (Includes Item # 6)	1	F002	10-24 Keps Nut		1
7	8996-9	Red Indicator Light Assembly	2	F004	1/4-20 Keps Nut		6
8	7941-3	Boot, Circuit Breaker	2	F025	10-24 x 3/8 PPHMS		1
9	7941-5	Circuit Breaker (7 Amp)	1	F228	#6 x 5/8 PPHSMS, SS		8
10	7941-2	Circuit Breaker (10 Amp)	1	F238	J Clip, Instrument Panel C15520-6A		8
11	8990-1	Hourmeter (Global)	1	F250	6-32 x 1/2 PPHMS		1
12	5995	Toggle Switch (Off-On)	1	F251	6-32 Keps Nut		2
13	5995-2	Switch Boot	1	F448	6-32 x 5/16 PPHMS		1
14	7306-14	Water Temperature Gauge	1	* Service Part Only.			
15	8997	Voltmeter Gauge	1	** May be ordered as an option. Contact your Walker dealer.			
16	7947-3	Wire Harness, Instrument Panel	1	NOTE: Refer to ELECTRICAL CONNECTORS , Page 40 for identification of all Electrical Wiring Service Parts.			
17	5975-1	Cable Tie (18# x 3-3/4")	2				
18	7307-1	Shock Mount (1.0 x .25)	3				
19	7391	Panel Box Mount Plate	2				
20	8385	Panel Box W/Graphic	1				
21	7977-1	Grommet (1/8 x 1-1/16)	1				

INSTRUMENT PANEL ASSEMBLY

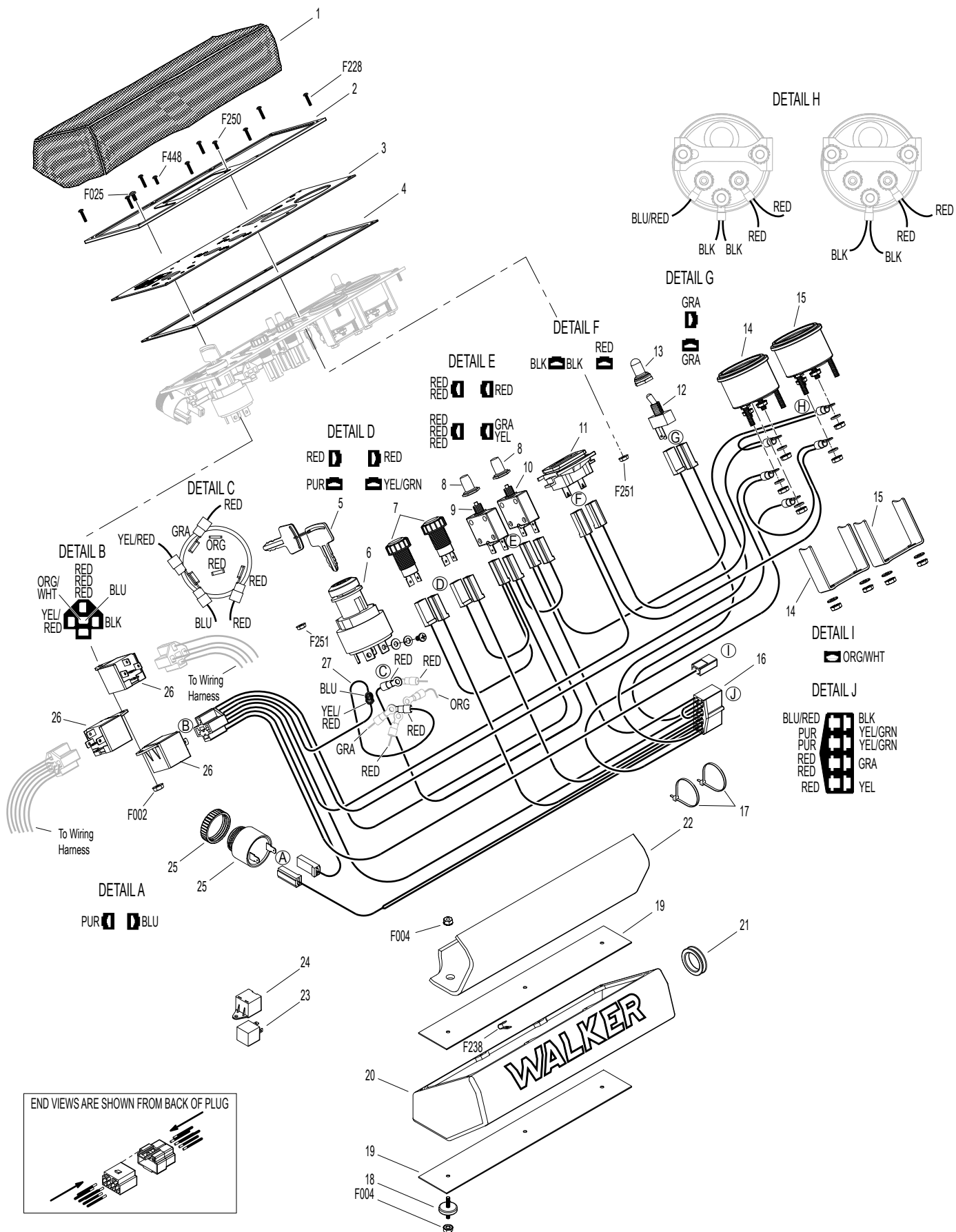

Beginning S/N 124860
 Effective Date 10-04-13
 Use only genuine Walker® replacement parts.

ELECTRICAL ASSEMBLY

ITEM NO.	PART NO.	DESCRIPTION	NO. REQ'D	ITEM NO.	PART NO.	DESCRIPTION	NO. REQ'D
Battery Assembly				Fasteners			
1	5975-1	Cable Tie (18# x 3-3/4")	6	F002		10-24 Keps Nut	10
2	5933	Battery Terminal Insul., Red (+)	1	F004		1/4-20 Keps Nut	5
3	5844-3	Battery Hold-Down Bar	1	F009		5/16-18 Whiz Locknut	1
4	5839	Hook Bolt	2	F019		1/4-20 ESNA Wing Nut	2
5	7390-1	Battery Pan	1	F025		10-24 x 3/8 PPHMS	5
6	NS	Battery (12V/340CCA/Dry)	1	F026		10-24 x 1/2 PPHMS	4
7	5932	Battery Terminal Insul., Black (-)	1	F027		10-24 x 5/8 PPHMS	2
8	6923	Battery Cable (-)	1	F031		1/4-20 x 5/8 Hex Bolt	2
Harness Assembly				F032		1/4-20 x 3/4 Hex Bolt	2
9	5975-3	Cable Tie (50# x 7")	3	F050		1/4 SAE Washer	4
10	5833	Cable Clamp (1/4)	1	F061		1/4 Internal Star Lock Washer	2
11	5942-4	PTO Safety Switch (NO)	1	F079		A/A66D Aluminum Pop Rivet	4
12	7940-11	Wire Harness	1	F085		3/16 Rivet Backup Washer	1
13	5832	Cable Clamp (1/2)	4	F090		1/4-20 x 2-1/2 Hex Bolt	1
14	8950	Wire Harness (9.5/10.0)	1	F093		5/16-18 x 1 Hex Bolt	1
15	7938	Lead Wire (Battery Charge)	1	F129		10-24 x 1/2 PTHMS	1
16	7306-10	Switch (235 Deg., 1/4-18 NPT)	1	F145		4-40 Keps Nut	2
17	7306-11	Switch (205 Deg., 3/8-18 NPT)	1	F232		10-32 Keps Nut	4
18	6942	Relay Switch (30/40 Amp) NC (Includes Items # 24 & 25)	2	F491		4-40 x 3/8 PPHMS	2
19	7433-2	Resistor, 50 Watt / .4 OHM 1%	1	* Service Part Only			
20	7833	Cable Clamp (7/8 x 1/4)	2	NOTE: Refer to ELECTRICAL CONNECTORS , Page 40 for identification of all Electrical Wiring Service Parts.			
21	7948-2	Time Delay Harness	1	NOTE: Decals for this assembly are not shown here. Refer to TRACTOR DECALS , Page 2 for Decal listing and placement information.			
22	7948-6	Time Delay Module	1				
23	7428-2	Fan Control Module W/P Plug	1				
24	6941-7	Relay Mount	*				
25	6941-6	Relay Switch (30/40 Amp)	*				
26	5942-5	Safety Switch (NO)	1				
27	6103-19	Adapter Harness	1				
28	7834-2	Wire Saddle (2 Wires)	1				
29	7943	Battery Cable (+)	1				
30	8941	Circuit Breaker (30 Amp) (Auto Reset/Sealed)	1				
31	7857-10	Breaker, Mount Bracket	1				
32	7941	Circuit Breaker (40 Amp) (Auto Reset/Sealed)	1				
33	7940-5	Circuit Breaker Jumper	1				

ELECTRICAL ASSEMBLY

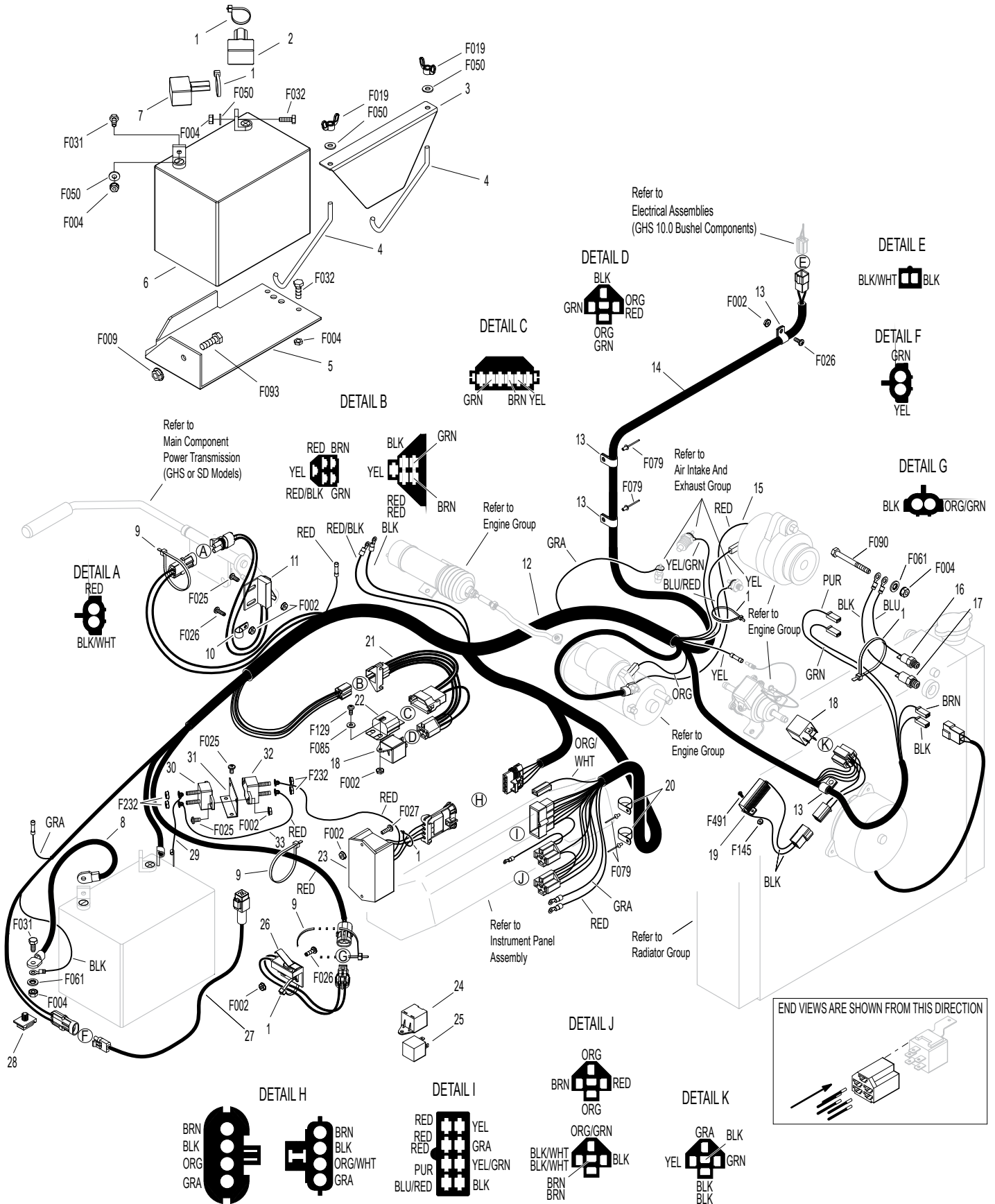

Beginning S/N 124860
 Effective Date 10-04-13
 Use only genuine **Walker®** replacement parts.

ELECTRICAL ASSEMBLIES (GHS 10.0 BUSHEL COMPONENTS)

ITEM NO.	PART NO.	DESCRIPTION	NO. REQ'D	ITEM NO.	PART NO.	DESCRIPTION	NO. REQ'D
10.0 Harness Components				Fasteners			
1	5519-4	Adapter Harness	1	F002		10-24 Keps Nut	4
2	5975-1	Cable Tie (18# x 3-3/4")	1	F025		10-24 x 3/8 PPHMS	1
3	7835	Frame Clip (3/16)	6	F037		10-24 x 5/8 PTH Screw	1
4	5975-3	Cable Tie (50# x 7")	1	F129		10-24 x 1/2 PTHMS	2
5	5536-2	Horn, Full Signal	*	F508		4-40 Keps Nut, SS	2
6	8950	9.5 / 10.0 Wire Harness	1	F509		4-40 x 1/2 Hex Head, SS	2
7	5977-2	Grommet, Cut (1/8 x 3/8)	1				
Grass-Pak® Switch Assemblies				* Service Part Only			
8	5594-6	Aluminum Shaft & Vane Assembly	1	NOTE: Refer to ELECTRICAL CONNECTORS , Page 40 for identification of all Electrical Wiring Service Parts.			
9	5592-14	Grass-Pak® Switch Assembly	1				
10	5833	Cable Clamp (1/4)	2				

ELECTRICAL ASSEMBLIES (GHS 10.0 BUSHEL COMPONENTS)

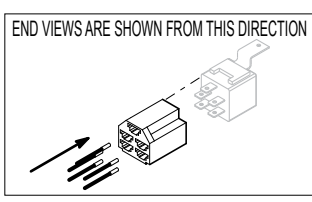
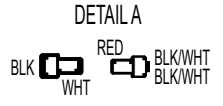
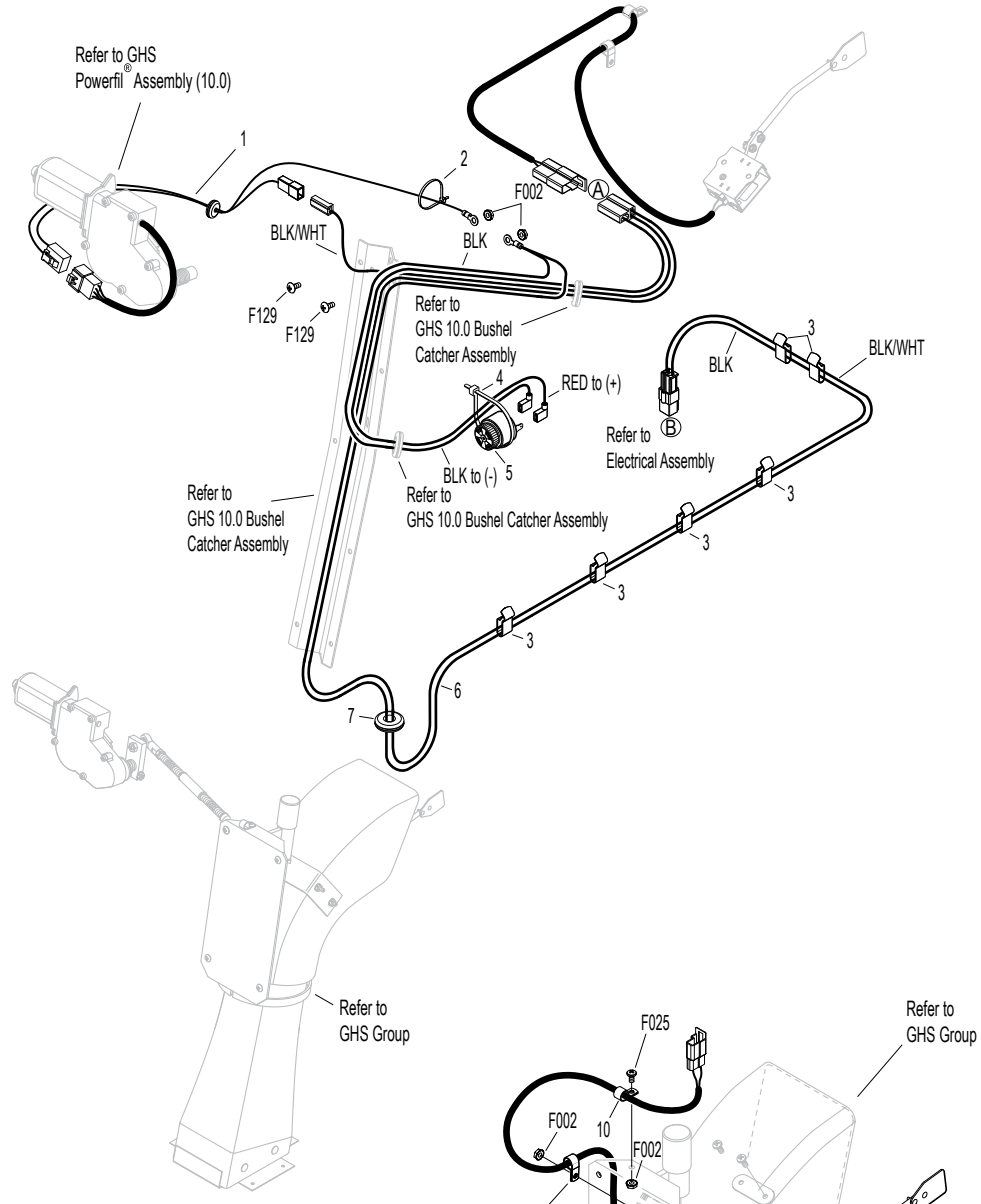

Beginning S/N 124860
 Effective Date 10-04-13
 Use only genuine **Walker**® replacement parts.

ELECTRICAL CONNECTORS

ITEM NO.	PART NO.	DESCRIPTION	NO. REQ'D	ITEM NO.	PART NO.	DESCRIPTION	NO. REQ'D
Electrical Wiring Service Parts				29	7942-1	2-Way Locking Connector, Female	*
1	5996-1	16-14 GA Butt Connector	*	30	7942-2	2-Way Connector, Male	*
2	5996-11	12-10 GA Butt Connector	*	31	7942-3	2-Way Connector, Female	*
3	7942-14	16-14 GA Shrink Connector	*	32	7942-10	2-Way Locking Connector, Male	*
4	7942-13	12-10 GA Shrink Connector	*	33	5940-8	3-Way Connector, Male	*
5	5995-1	Wire Terminal Adapter	*	34	7942-9	3-Way Connector, Male	*
6	5996-4	16-14 GA Bullet Conn., Male	*	35	8944	3-Way Locking Connector, Male	*
7	5996-5	16-14 GA Bullet Conn., Female	*	36	8944-1	3-Way Locking Connector, Female	*
8	5940-4	16-14 GA Spg. Loaded Term., Female	*	37	7942-11	4-Way Connector, Male	*
9	5940-7	Wire Clip, Female	*	38	7942-12	4-Way Connector, Female	*
10	5996	1/4 x 16-14 GA QKS Term., Female	*	39	7942-5	5-Way Connector, Male	*
11	5996-2	3/16 x 22-18 GA QKS Term., Female	*	40	5940-2	5-Way Connector, Male	*
12	7996	16-14 GA QKS Term., Female	*	41	8942-1	5-Way Connector, Female	*
13	5940-5	16-14 GA Spg. Loaded Term., Male	*	42	7942-6	6-Way Connector, Male	*
14	5996-0	1/4 x 22-18 GA QKS Term., Male	*	43	7942-7	6-Way Connector, Male	*
15	5996-18	16-14 GA Ring Term. (#8) Nylon Insulated	*	44	7942-8	8-Way Connector, Male	*
16	7996-1	1/4 x 16-14 GA QKS Term., Male	*	45	8942-2	8-Way Connector, Female	*
17	5996-8	6 GA Ring Lug (5/16)	*	46	8942-3	5-Way Connector, Male	*
18	5996-9	22-18 GA Ring Term., #10	*	47	5940-9	3-Way Connector (M)	*
19	5996-10	16-14 GA Ring Term. (5/16)	*	48	7942-15	6-Way Connector (Female)	*
20	5996-12	12-10 GA Ring Term. (5/16)	*	49	7940-3	Packard Plug (Male)	*
21	5996-13	16-14 GA Ring Term., # 10	*	50	7940-4	Packard Plug (Female)	*
22	5996-15	12-10 GA Ring Term. (1/2)	*	* Service Part Only			
23	5996-16	6 GA Ring Terminal (1/4)	*	NOTE: Not all Electrical Connectors are used with all assemblies.			
24	5996-17	16-14 GA Ring Term. (1/4)	*	NOTE: Refer to ELECTRICAL ASSEMBLY , Page 36 for locations of Wiring Harness and of all Electrical Wiring Service Parts.			
25	5996-20	12-10 GA Ring Term. (1/4)	*				
26	5996-21	12-10 GA Ring Term., #10	*				
27	7942-4	Single Connector, Male	*				
28	8942	2-Way Connector, Male	*				

ELECTRICAL CONNECTORS

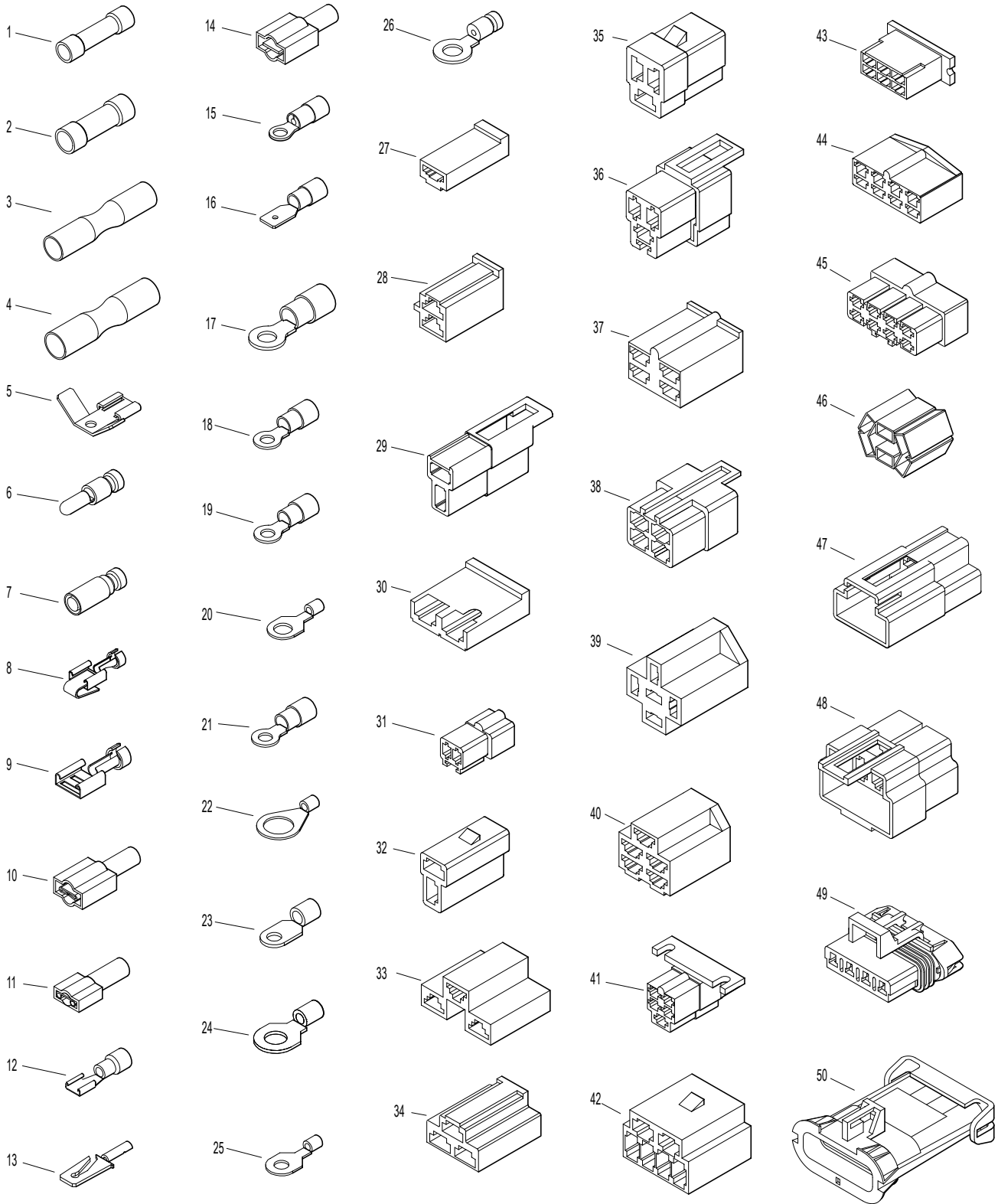

Beginning S/N 124860
Effective Date 10-04-13
Use only genuine Walker® replacement parts.

LUBRICATION POINTS

ITEM NO.	LOCATION	LUBRICATION TYPE	NO. PLACES	ITEM NO.	LOCATION	LUBRICATION TYPE	NO. PLACES
Lubrication Points				16	Belt Tightener Pivot, Ground Drive	Grease	1
1	Steering Lever Pivot	Grease	4	17	Throttle Control Cable Ends	Oil	2
2	Body Hinge Point	Oil	2	18	Cold Start Lever	Grease	1
3	Deck-to-PTO Coupling (Grease Spline Slide Area)	Grease	1	19	Catcher Hinge Point	Oil	2
4	FSC Actuator Rod Pivot Pins	Oil	2	20	Rear Wheel Bearings	Grease	2
5	(FSC) Friction Body Pivot	Grease	1	21	Engine Dipstick / Oil Filler	Oil**	1
6	FSC Lever Pivot	Grease	1	22	PTO Gearbox Dipstick	Oil**	1
7	FSC Lever Fork (Grease Slide Area)	Grease	1	23	Belt Tightener Pivot, Blower Drive (GHS Model Only)	Grease	1
8	Deck Support Arm Pivot	Grease	2	24	Hydrostatic Drive	Oil**	2
9	Universal Joint Tube Assembly	Grease*	1	25	Throttle Control Pivot	Oil	1
10	Parking Brake Lever	Grease	1	* Grease every eight (8) hours.			
11	Universal Joint Quick Connect Spline (Grease Slide Area)	Grease	1	** See MDD Operator's Manual for procedure for checking and changing oil in Engine Crankcase, Hydrostatic Transmissions and Gear Axles.			
12	Gear Axle	Oil**	2	NOTE: See Model MDD Operator's Manual for proper lubrication intervals.			
13	PTO Clutch Lever Pivot	Grease	1				
14	Brake Actuator Rod and Brake Band Pivot Pins (Clevis)	Oil	1				
15	Clutch Actuator Push Rod	Grease	3				

LUBRICATION POINTS

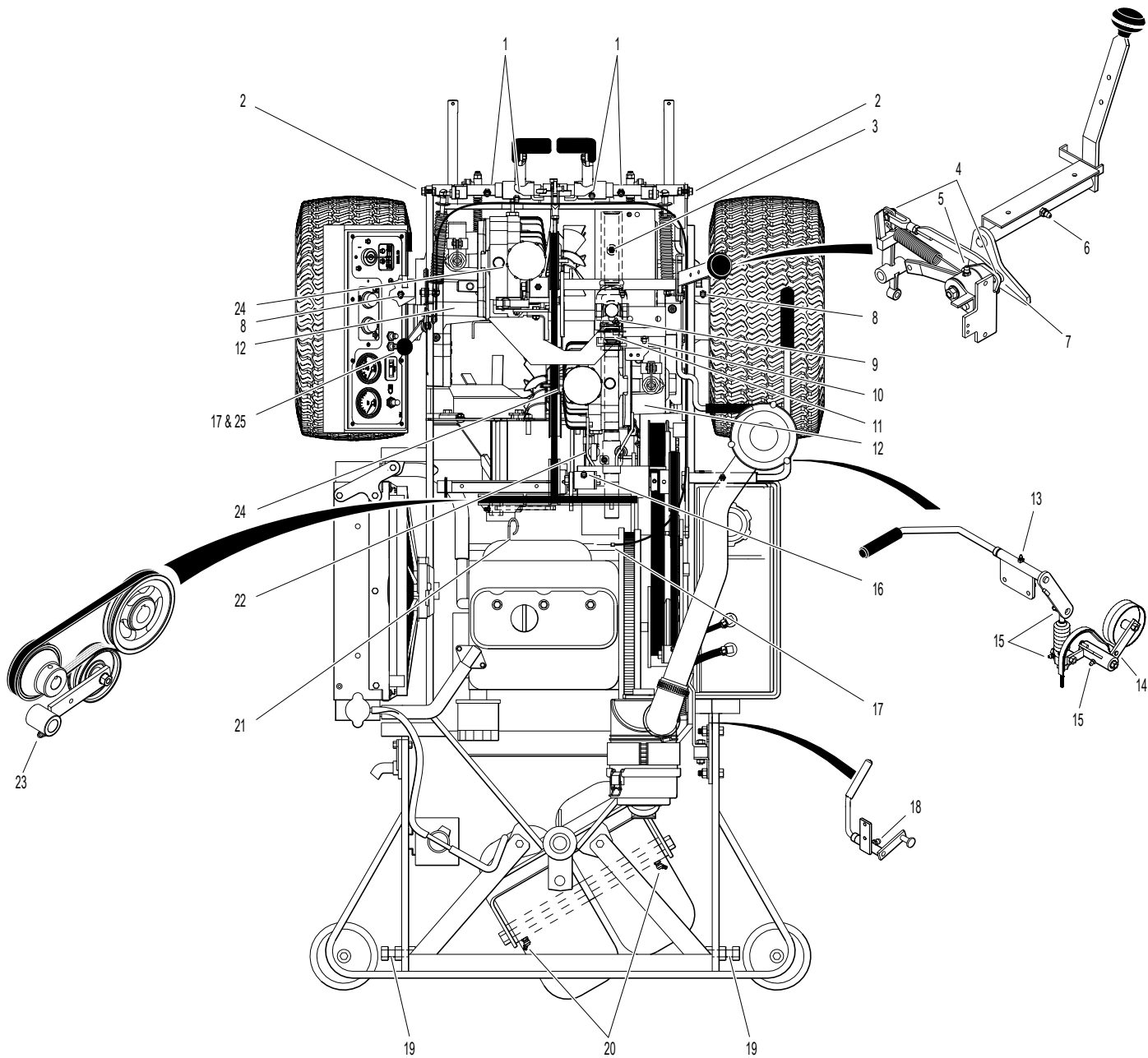

Beginning S/N 124860
Effective Date 10-04-13
Use only genuine **Walker**® replacement parts.

WIRING SCHEMATIC

WALKER MODEL D21d Beginning S/N 2011-108842

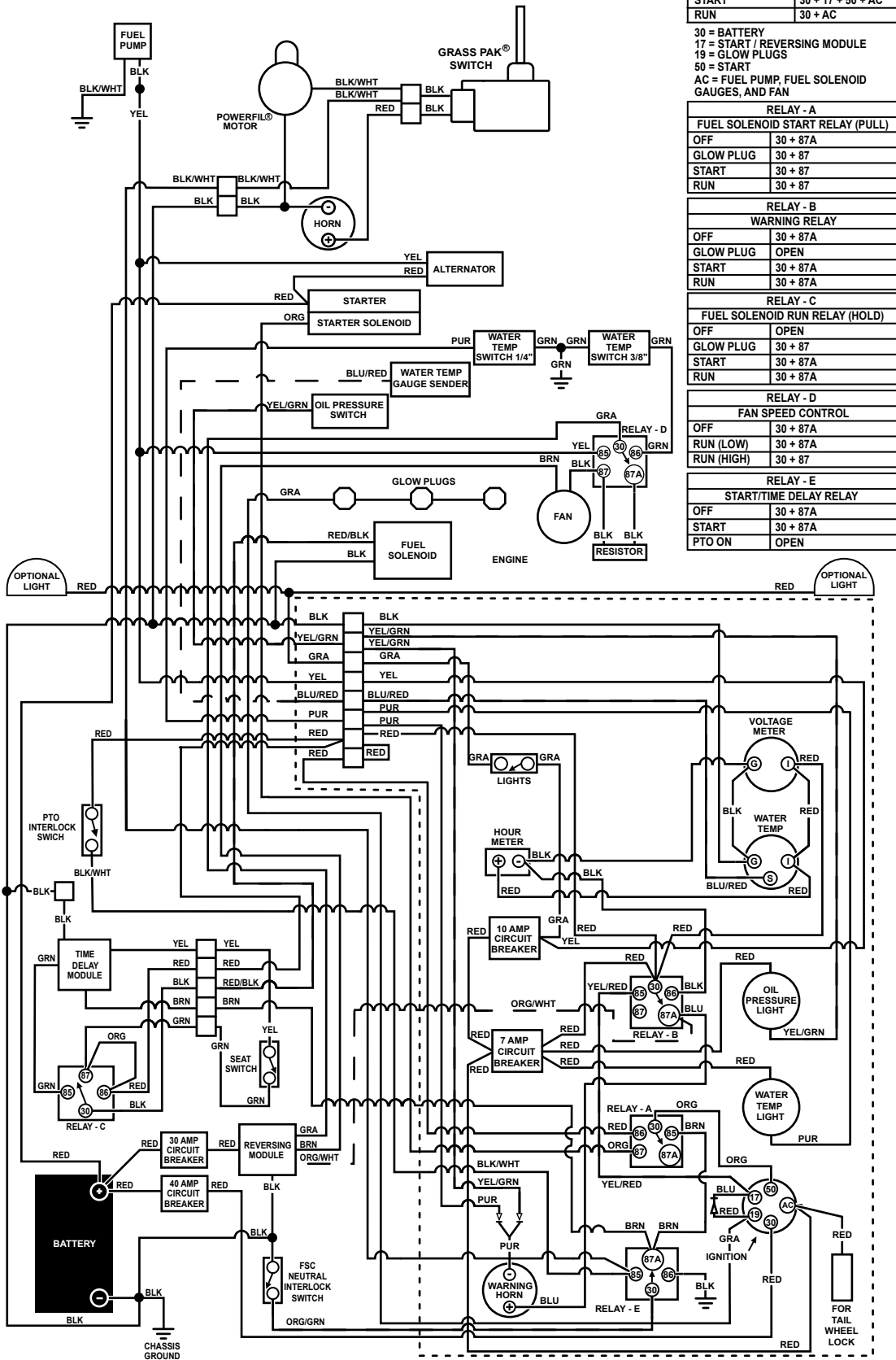

IGNITION SWITCH CIRCUITS	
OFF	ALL OPEN
GLOW PLUG	30 + 19 + AC
START	30 + 17 + 50 + AC
RUN	30 + AC

30 = BATTERY
17 = START / REVERSING MODULE
19 = GLOW PLUGS
50 = START
AC = FUEL PUMP, FUEL SOLENOID
GAUGES, AND FAN

RELAY - A FUEL SOLENOID START RELAY (PULL)	
OFF	30 + 87A
GLOW PLUG	30 + 87
START	30 + 87
RUN	30 + 87

RELAY - B WARNING RELAY	
OFF	30 + 87A
GLOW PLUG	OPEN
START	30 + 87A
RUN	30 + 87A

RELAY - C FUEL SOLENOID RUN RELAY (HOLD)	
OFF	OPEN
GLOW PLUG	30 + 87
START	30 + 87A
RUN	30 + 87A

RELAY - D FAN SPEED CONTROL	
OFF	30 + 87A
RUN (LOW)	30 + 87A
RUN (HIGH)	30 + 87

RELAY - E START/TIME DELAY RELAY	
OFF	30 + 87A
START	30 + 87A
PTO ON	OPEN

LIMITED WARRANTY FOR WALKER COMMERCIAL RIDER MOWER

1. WHAT THIS WARRANTY COVERS, AND FOR HOW LONG:

Walker Manufacturing company will, at its option, repair or replace, without charge, any part covered by this warranty which is found to be defective in material and/or workmanship within one (1) year* after date of sale to the original retail purchaser unless the product is used for rental purposes, in which case this warranty is limited to ninety (90) days. At Walker's request, customer will make the defective part available for inspection by Walker and/or return the defective part to Walker, transportation charges prepaid. All parts and components of the Walker Mower are covered by this warranty **except** the following components which are warranted separately by their respective manufacturers:

Kubota Engine
Battery

The available warranties covering these items are furnished with each mower. Walker does not assume any warranty obligation, liability or modification for these items, which are covered exclusively by the stated warranty of the respective manufacturers noted above.

* Extended warranties are offered for the following powertrain components:

- A three (3) year unlimited hour warranty is offered for the Walker P/N 6200-9 Gear Axle Assembly.
- A three (3) year or 3000 hour (whichever comes first) warranty is offered for Eaton Model 7 Hydrostatic transmissions; covers full cost of replacement up to 1000 hours of use, and after 1000 hours warranty coverage is prorated against 3000 hours.

2. WHAT THIS WARRANTY DOES NOT COVER:

- A. This warranty does not cover defects caused by depreciation or damage caused by normal wear, accidents, improper maintenance, improper use or abuse of the product, alterations, or failure to follow the instructions contained in the Operator's Manual for operation and maintenance.
- B. The customer shall pay any charges for making service calls and/or for transporting the mower to and from the place where the inspection and/or warranty work is performed.

3. HOW TO OBTAIN SERVICE UNDER THIS WARRANTY:

Warranty service can be arranged by contacting the dealer where you purchased the mower or by contacting Walker Manufacturing Company, 5925 East Harmony Road, Ft. Collins, CO 80528. Proof of the date of purchase may be required to verify warranty coverage.

4. WARRANTY LIMITATION:

- A. **THERE IS NO OTHER EXPRESS WARRANTY. ANY WARRANTY THAT MAY BE IMPLIED FROM THIS PURCHASE INCLUDING MERCHANTABILITY AND FITNESS FOR A PARTICULAR PURPOSE IS HEREBY LIMITED TO THE DURATION OF THIS WARRANTY AND TO THE EXTENT PERMITTED BY LAW ANY AND ALL IMPLIED WARRANTIES ARE EXCLUDED.** Some states do not allow limitations on how long an implied warranty lasts, so the above limitations may not apply to you.
- B. **WALKER WILL NOT BE LIABLE FOR ANY INCIDENTAL, CONSEQUENTIAL, OR SPECIAL DAMAGES AND/OR EXPENSES IN CONNECTION WITH THE PURCHASE OR USE OF THE MOWER.** Some states do not allow the exclusion or limitation of incidental or consequential damages, so the above limitation(s) or exclusion(s) may not apply to you.
- C. Only the warranty expressed in this limited warranty shall apply and no dealer, distributor, or individual is authorized to amend, modify, or extend this warranty in any way. Accordingly, additional statements such as dealer advertising or presentations, whether oral or written, do not constitute warranties by Walker, and should not be relied upon.
- D. This warranty gives you specific legal rights, and you may also have other rights which vary from state to state.

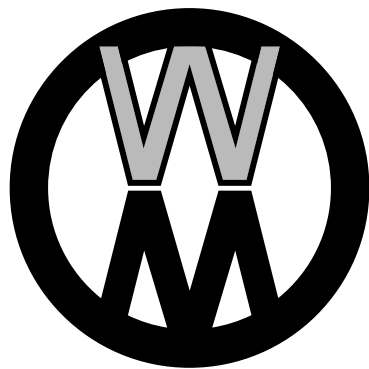

WALKER

WALKER MFG. CO. • 5925 E. HARMONY ROAD, FORT COLLINS, CO 80528 • (970) 221-5614
FORM NO. 100413 PRINTED IN USA www.walkermowers.com ©2014 WALKER MFG. CO