



## CUSTOMER SERVICE

574.848.7941 | [SUPPORT@EARTHWAY.COM](mailto:SUPPORT@EARTHWAY.COM) | [WWW.EARTHWAY.COM](http://WWW.EARTHWAY.COM) | 1009 Maple Street, Bristol, IN 46507

## ONE YEAR WARRANTY

EarthWay Products, Inc. warrants this product free of defects in original workmanship and materials for a period of one year to the end user with the original purchase receipt. If a manufacturing non-conformance is found, EarthWay Products, Inc. at its discretion will repair or replace the part(s)/product at no charge provided the failure is not the result of incorrect installation, mishandling, misuse, tampering, or normal wear and tear as determined by EarthWay.

EarthWay at its discretion may require that the part(s) or product be returned along with the original purchase receipt for examination and compliance with the terms of this warranty. Do not return any product without first receiving authorization from EarthWay Products, Inc.

To seek remedy under this warranty, contact EarthWay Products, Inc. at 574-848-7491, [support@earthway.com](mailto:support@earthway.com) or write to EarthWay Products, Inc. 1009 Maple Street, Bristol, IN 46507 and describe the nature of the manufacturing defect. **SPECIFIC LIMITATIONS:** This warranty covers only the part(s) or product; any labor charges associated with repair or replacement of non-conformances are specifically excluded. Due to the corrosive nature of most fertilizers and ice melt products, EarthWay Products, Inc. makes no warranty against and specifically excludes part(s) or product degradation or failure due to corrosion or its effects.

---

---

## OPERATING INSTRUCTIONS

Before filling hopper, become familiar with the operation of this spreader.

- ☑ Obtain proper setting for material to be used from the SETTING MATRIX included with this spreader.
- ☑ Move stop bolt on rate gauge assembly to the proper setting.
- ☑ While turning handle crank and walking forward, push control lever forward to the stop bolt. To stop, pull lever back to close flow holes while continuing to crank handle and walking forward.
- ☑ When finished, empty any remaining material from hopper.
- ☑ Thoroughly wash spreader and allow to dry before storing.
- ☑ No oiling is necessary.

The settings furnished on the Rate Setting Matrix are intended as a guide only. Variations in physical characteristics of material applied, walking speed, and roughness of ground surface may require slightly different spreader settings. Due to the above conditions, the manufacturer makes no warranty as to the uniformity of coverage actually obtained from the settings listed.

## HOW TO ORDER SPARE PARTS

All spare parts listed herein may be ordered direct from the manufacturer. Be sure to give the following information when ordering.

- Model Number
- Part Number
- Part Description

You can contact us by calling (574) 848-7491 to place an order with a credit card, or purchase online at <https://www.earthway.com/product-category/parts/> Questions? Email us at <mailto:sales@earthway.com>

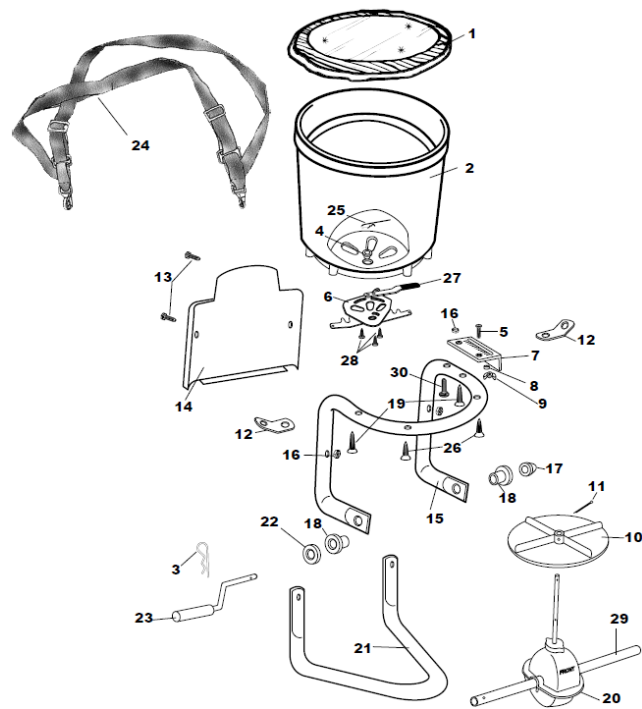

2750 Handle Crank/Bag Support Parts List		
KEY #	PART #	DESCRIPTION
1	77000	HEAVY DUTY RAIN COVER
2	13103	HOPPER
3	33110	HAIR PIN CLIP #214 ZINC
4	12220	HOPPER BUSHING
5	37103	#10-24 X 3/4" CARRIAGE BOLT
6	60128	LEVER & SHUT OFF ASSEMBLY
7	41262	FLOW GAUGE
8	12147	SPACER (PIVOT LINK)
9	32106	10-24 WING NUT ZINC
10	12109	IMPELLER
11	36105	1/8" X 1 1/4" COTTER PIN S.S.
12	44226	HARNES CLIP
13	37101	1/4-20 X 1 1/2" CARRIAGE BLT
14	12188	BELLY GUARD
15	23103	FRAME
16	32100	1/4-20 HEX NUT ZINC
17	12166	CRANK SHAFT CAP
18	12137	SPLIT BEARING
19	31128	#10 X 1 1/2" TYPE A FHPS
20	60126	GEAR BOX ASSEMBLY
21	23600	STAND
22	34103	1"OD X 17/32"ID X 1/32" WASHER
23	60124	HANDLE CRANK ASSEMBLY
24	60122	HARNES ASSEMBLY
25	33117	AGITATOR
26	31108	#10 X 1 1/4" TYPE A FHPS
27	19114	.125" X .75" X 2" GRIP BLK
28	31138	#8 X 3/8" PMT #8 HD COARSE
29	23608	CRANK SHAFT
30	37109	1/4-20 X 1 1/4" CARRIAGE BOLT

**You can find replacement Nuts and Bolts at your local hardware store.**

# Hand Crank Spreader Rate Setting Instructions

## YOU WILL NEED

- Tape measure
- Pencil & Pad
- Scale
- Bucket/container

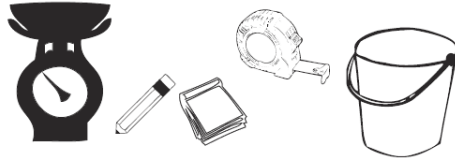

## To Calculate RATE SETTINGS: (Use the Chart on the next page to fill in numbers)

- ☑ Determine how much material is to be applied per 1,000 sq./ft. This is determined on the bag based on bag weight and total area of coverage if not directly stated on the bag the recommended number of pounds per 1,000 sq./ft.
- ☑ Measure off a distance of 50 feet, preferably on a paved surface such as a parking lot.
- ☑ Weigh out enough of the material to be applied to fill the bag/hopper at least half full.
- ☑ Record the weight for future use.
- ☑ With the unit positioned correctly for comfortable use, (on your left hip for 2700A/2750 or on your chest for the 3100/3200 models) and the bag/hopper at least half full of the material to be spread, position yourself far enough before the beginning of the 50 foot test area so that you will achieve the desired speed before you reach the starting line.
- ☑ Select the Setting Rate position that you feel would be an appropriate setting on the seeder/spreader (start in the middle).
- ☑ Start walking at a NORMAL pace cranking the handle so that it makes one revolution for each step with either your right or left foot to ensure the proper distribution rate.
- ☑ As you cross the starting line (of the 50 feet) move the rate lever to the open position against the stop.
- ☑ Continue from the starting line with the unit spreading the material. As you cross the finish line move the rate control lever to the closed position.
- ☑ Stop walking and measure the spread width and note it below.
- ☑ Return to the start point and empty the remaining material from the hopper into your weighing container and re-weigh.

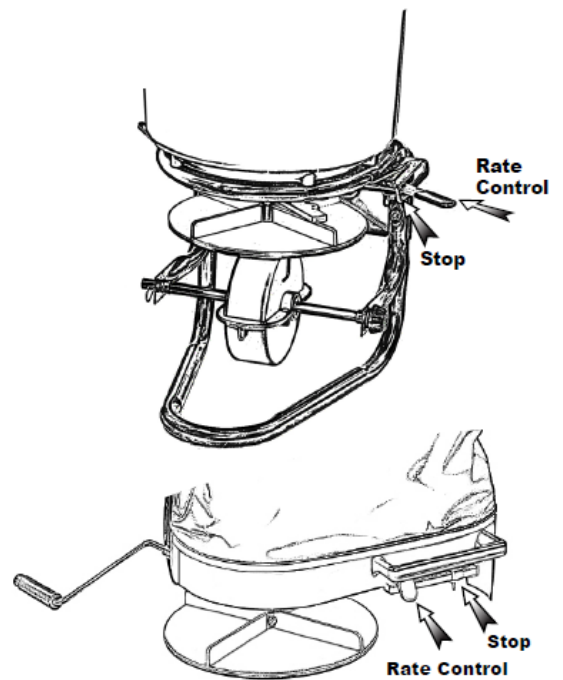
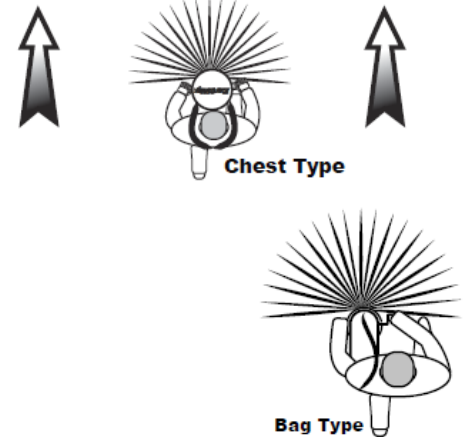
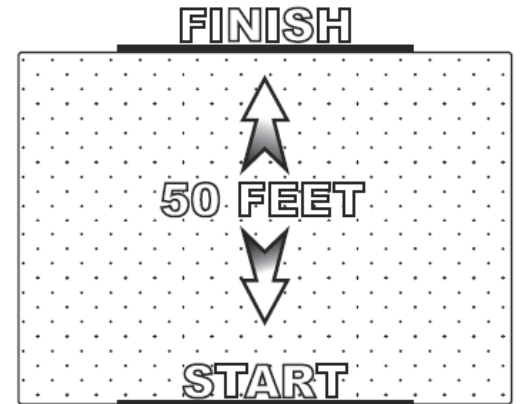

## Spreading Paths

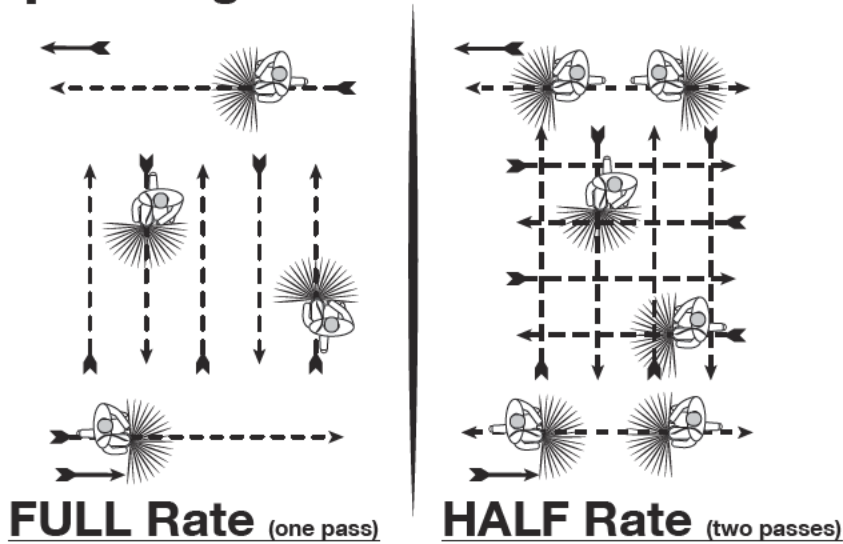

### CHART

Desired Application Rate (lbs./1,000 sq. ft.) \_\_\_\_\_

To determine the desired application rate divide the area (sq. ft.) that the bag says it should cover, by the weight of the bag, and then multiply by 1,000. (Example: 5,000 sq. ft. / 25 lbs. = .005 x 1,000 = 5lbs. per 1,000 sq. ft.)

\_\_\_\_\_ Weight of Material Placed in Bag/Hopper  
 - \_\_\_\_\_ Subtract the Weight of Material Left in Bag/Hopper  
 = \_\_\_\_\_ Weight of Material Used

**X** \_\_\_\_\_ Multiply by the Width of Spread Area by Length (50 feet)  
 = \_\_\_\_\_ Total Spread Area

Divide the Weight of Material Used by the Total Spread Area = \_\_\_\_\_ lbs.\sq. ft. Multiply the lbs.\sq. ft. from above times 1,000 = \_\_\_\_\_ lbs.\1,000 sq. ft.

Compare the results of your test to the desired application rate.

Adjust the rate setting stop accordingly and run through the test again. Repeat this process until you have achieved the desired application rate.

These settings are intended as a guide only. Variations in physical characteristics of material applied, brisk walking speed (3 mph.), and roughness of ground surface may require slightly different spreader settings. Due to the above conditions, Earthway Products, Inc. makes no warranty as to the uniformity of coverage actually obtained from the setting listed.