

Parts Catalog

Z-SPRAY

Model No. ZS5260XL—Serial No. 404314159 and Up

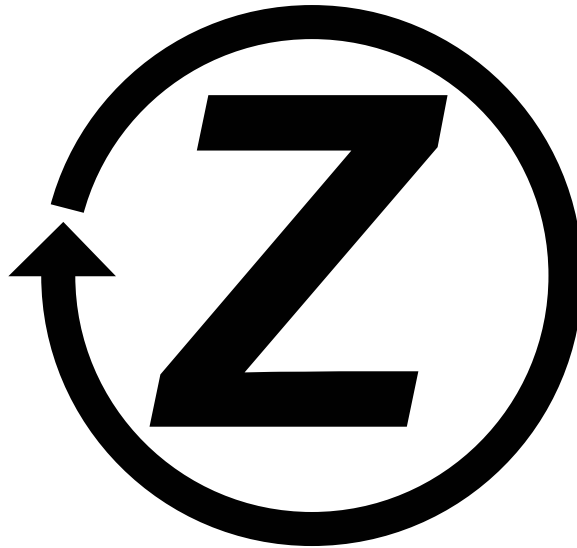

Ordering Replacement Parts

To order replacement parts, please supply the part number, the quantity, and the description of each part desired.

Understanding Reference Numbers

Each identified part in an illustration has a reference number. The reference number for a part also appears in the parts list, along with other information about the part.

This catalog uses two special reference number formats, one to indicate parts in a service assembly and another to indicate the quantity of a given part in an illustration.

Service Assembly Reference Numbers

Parts in service assemblies have reference numbers in the form a:b. The a represents the reference number of the entire service assembly and the b represents a sequential number unique to each part within the service assembly.

For example, a wheel assembly might be identified by reference number 6, the tire by 6:1, the valve by 6:2, and the wheel by 6:3. When you order the assembly identified by reference number 6, you receive all parts identified by reference numbers 6:1, 6:2, and 6:3. However, you may also order any part individually. Reference numbers of this type appear in illustration and in parts lists.

Reference Numbers Indicating Quantity

In an illustration, if a reference number indicates more than one part, the reference number has the form nX y. The n represents the quantity of the part, the X is the multiplication symbol, and the y represents the reference number.

For example, in an illustration, the reference number 2X 37 means that two of the parts identified by reference number 37 are indicated.

Contents

Main Frame Assembly	4
Motion Control Assembly	6
Park Brake Assembly	8
Tire and Wheel Assembly	10
Hopper Assembly	12
Spray System Assembly	14
Hose Reel Tank Assembly	16
Manifold Assembly	18
Spray Boom Assembly	20
Liquid Valve Assembly	22
Fuel Assembly	24
Engine Assembly	26
Hydraulic Assembly	28
Electrical Assembly	30

Main Frame Assembly

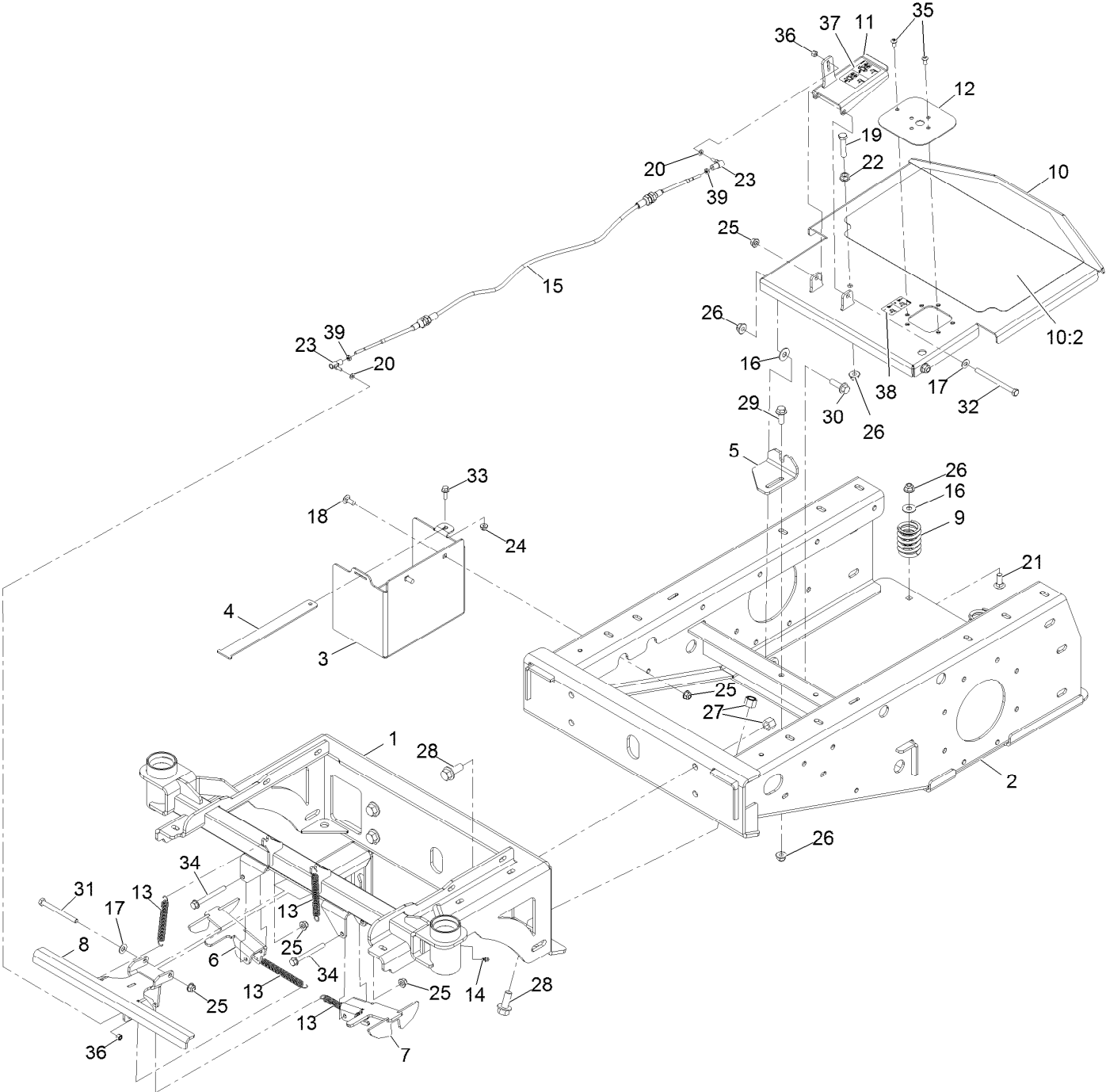

Main Frame Assembly (continued)

<i>Ref.</i>	<i>Part Number</i>	<i>Qty.</i>	<i>Description</i>	<i>Ref.</i>	<i>Part Number</i>	<i>Qty.</i>	<i>Description</i>
1	135-5179	1	Frame-Front	22	135-6806	1	Nut-Hex Flange
2	135-5171	1	Frame-Rear	23	135-5682	2	Ball Joint-SS
3	135-5199	1	Box-Battery	24	135-6108	1	Nut-Hex Flange
4	135-5493	1	Strap-Battery	25	135-6109	6	Nut-Hex Flange
5	135-5494	1	Bracket, Lower Cable	26	135-6110	7	Nut-Hex Flange
6	135-5195	1	Wing-Capture, Rt	27	HDW14426	6	Nut,1/2-13,NYL INS,ST/ST,18-8
7	135-5194	1	Wing-Capture, Lt				
8	135-5369	1	Capture-Lcs	28	135-6207	6	Screw-HHF
9	135-5654	3	Spring-Compression	29	135-6208	1	Screw-HHF
10	135-5656	1	Plate-Foot	30	135-6211	2	Screw-HHF
10:2	135-5655	1	Pad-Grip	31	135-6217	1	Screw-HH
11	135-5191	1	Pedal-Foot	32	135-6218	1	Screw-HH
12	135-5561	1	Panel, Foot Switch	33	135-6221	1	Screw-HHF
13	135-5652	4	Spring-Extension	34	135-6222	2	Screw-HHF
14	302-63	2	Fitting-Grease, Zerk	35	135-6367	2	Screw-HSBH
15	135-5644	1	Cable-Caster, Locking	36	HDW05856	2	Nut,NYL Lock,#10-32,ST/ST 18-8
16	1126	5	Washer-Flat				
17	107-0279	2	Washer	37	135-6430	1	Decal-Lock, Caster
18	126-0695	2	Screw-CARR	38	135-6728	1	Decal-Spray Foot Button
19	126-0710	1	Screw-HH	39	520-0019	2	Nut,Hex Jam Mch Scr,10-32,Sst
20	126-0759	2	Washer-Flat				
21	126-0980	3	Screw-CARR				

Motion Control Assembly

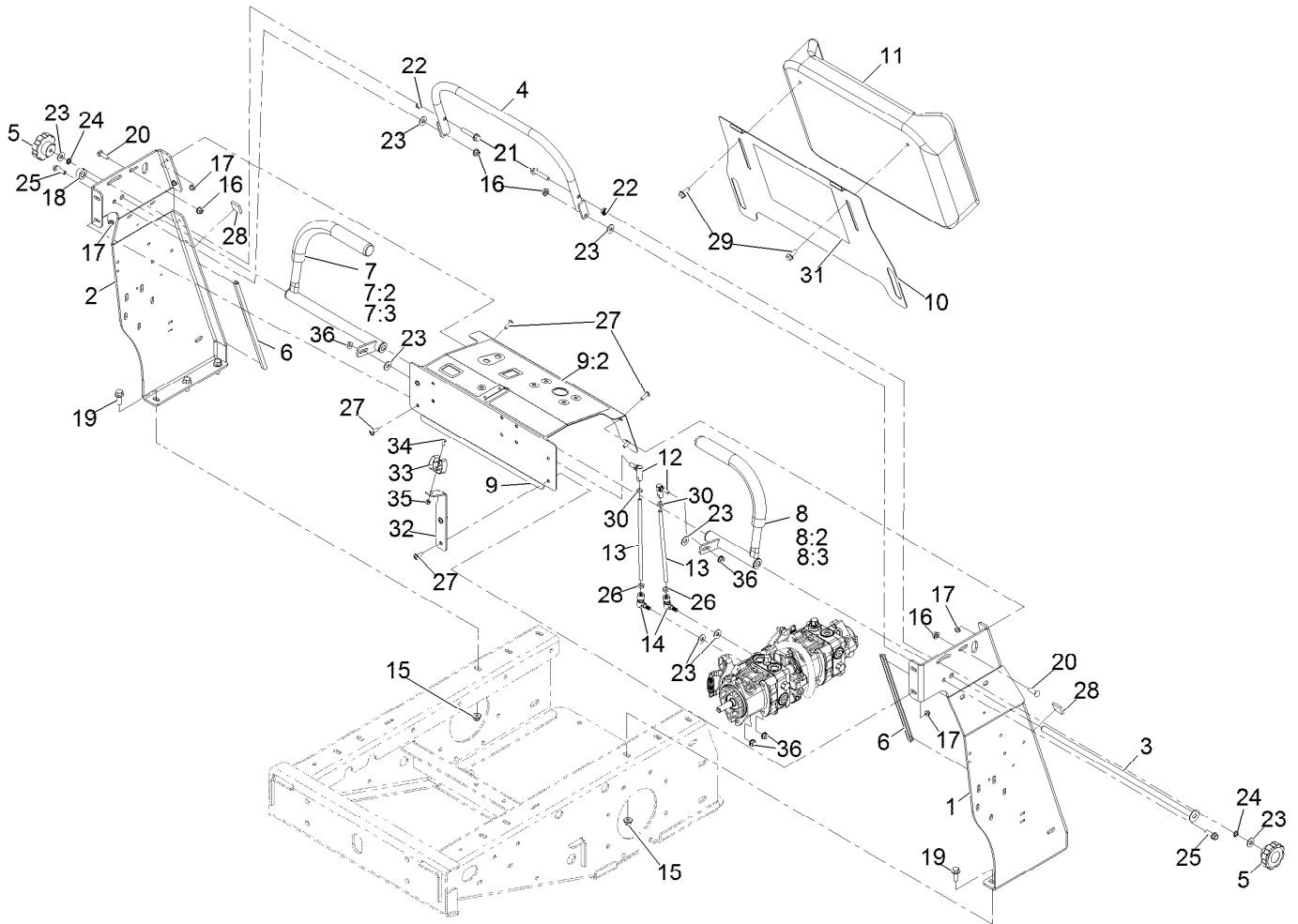

Motion Control Assembly (continued)

<i>Ref.</i>	<i>Part Number</i>	<i>Qty.</i>	<i>Description</i>	<i>Ref.</i>	<i>Part Number</i>	<i>Qty.</i>	<i>Description</i>
1	135-5423	1	Upright-Tower, Lt	18	135-6192	1	Collar
2	135-5425	1	Upright-Tower, Rt	19	135-6208	6	Screw-HHF
3	135-5430	1	Rod-Pivot, Joy Stick	20	HDW17294	2	Bolt, Carriage, 5/16-18X1, ST/ST 18-8
4	135-5427	1	Bar-Speed	21	135-5779	2	Screw-HHF
5	135-5689	2	Knob-Fluted	22	118-1722	2	Nut, Hex Flange, 5/16-18, Sst, Rie2006
6	135-5336	2	Strip-Trim, 12.0"	23	HDW14535	8	Flat Washer, 5/16 Nom, ST/ST, 18-8
7	135-5738	1	Stick-Joy, Rt	24	135-6286	2	Washer-Lock
7:2	1-633257	1	Grip-Control, Motion	25	135-6272	2	Screw-HHF
7:3	135-5694	2	Bushing-Flange	26	107-0282	2	Nut-Hex
8	135-5739	1	Stick-Joy, Lt	27	135-7080	8	Screw-Hsbhf
8:2	1-633257	1	Grip-Control, Motion	28	93-9155	2	Velcro
8:3	135-5694	2	Bushing-Flange	29	126-2712	2	Screw-HHF 5/16-18 X 3/4 SS
9	135-6123	1	Panel-Control	30	135-6512	2	Nut-Hex
9:2	135-6223	1	Decal-Control Panel	31	135-6281	1	Decal-Spray Chart
10	135-5498	1	Plate, Knee Pad	32	135-5506	1	Mount-Gun
11	135-5334	1	Pad-Knee, Z-Spray/Z-Plug	33	135-5661	1	Holder-Tool, Clip
12	135-5257	2	Balljoint-SS	34	135-6374	1	Screw-HSBH
13	135-5681	2	Rod-Control, Motion	35	135-6342	1	Nut-Hex Flange
14	135-5718	2	Ball Joint-Quick Disconnect, SS	36	107-0380	4	Nut-HHF
15	135-6110	6	Nut-Hex Flange				
16	135-6109	4	Nut-Hex Flange				
17	135-6108	8	Nut-Hex Flange				

Park Brake Assembly

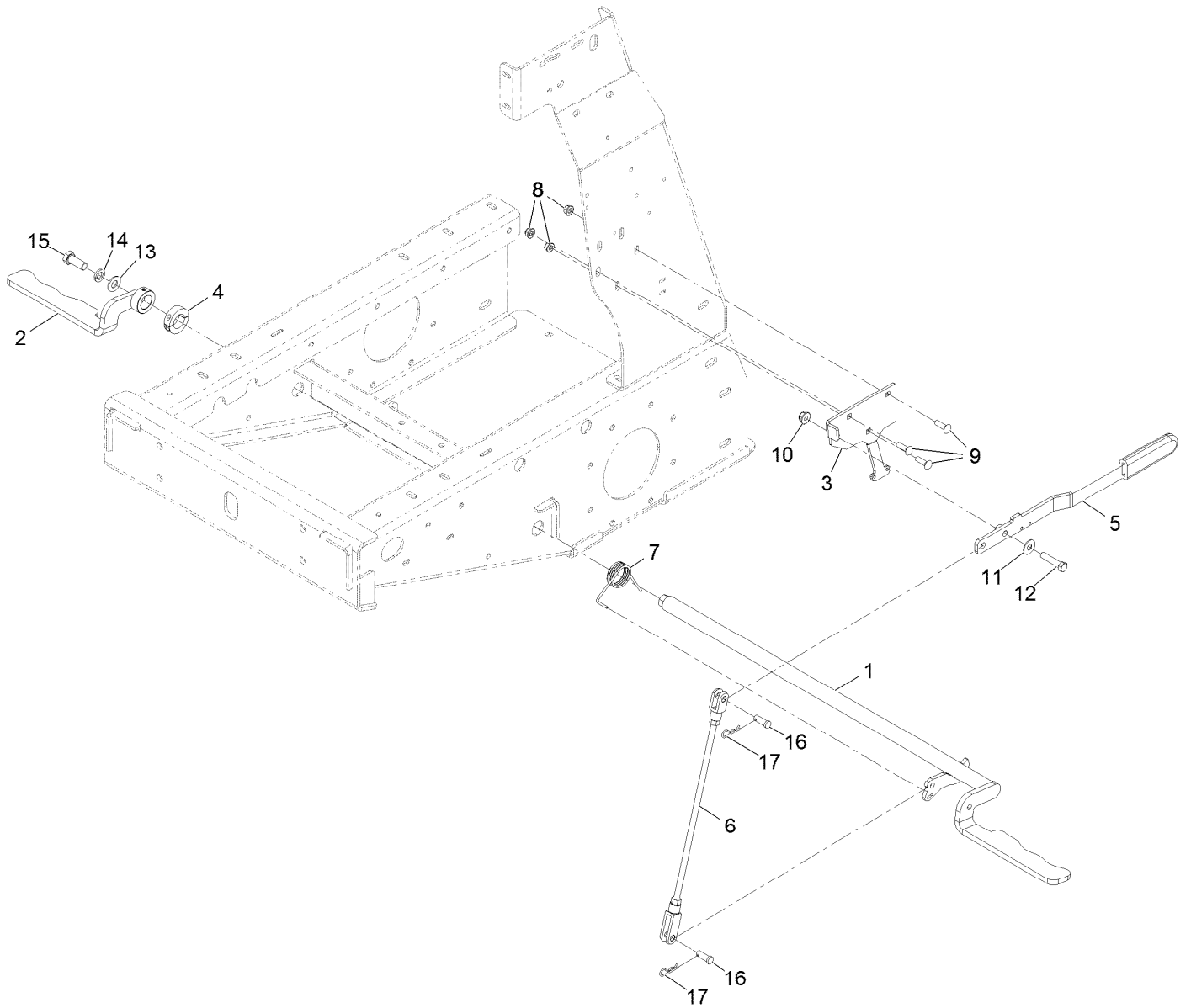

Park Brake Assembly (continued)

<i>Ref.</i>	<i>Part Number</i>	<i>Qty.</i>	<i>Description</i>	<i>Ref.</i>	<i>Part Number</i>	<i>Qty.</i>	<i>Description</i>
1	135-5380-03	1	Arm-Brake, Lt [black]	10	104-8301	1	Nut-Nyloc 3/8-16 Flg
2	135-5376-03	1	Arm-Brake, Rt [black]	11	1126	1	Washer-Flat
3	135-5432	1	Bracket-Handle, Brake	12	323-52	1	Screw-HH 3/8-16 X 1 3/4
4	116-7271	1	Collar-Locking	13	3256-26	1	Washer-1/2 SAE
5	135-6059	1	ASM, Handle-Brake	14	3253-7	1	Washer-Lock 1/2
6	135-6066	1	ASM, Rod-Brake	15	106-0378	1	Screw (.50-20Unfx1.25 Grade 8]
7	135-6106	1	Spring-Torsion	16	1-808284	2	Pin-Clevis
8	135-6109	3	Nut-Hex Flange	17	135-6284	2	Pin-Hair
9	HDW17294	3	Bolt,Carriage,5/16-18X1,ST/ST 18-8				

Tire and Wheel Assembly

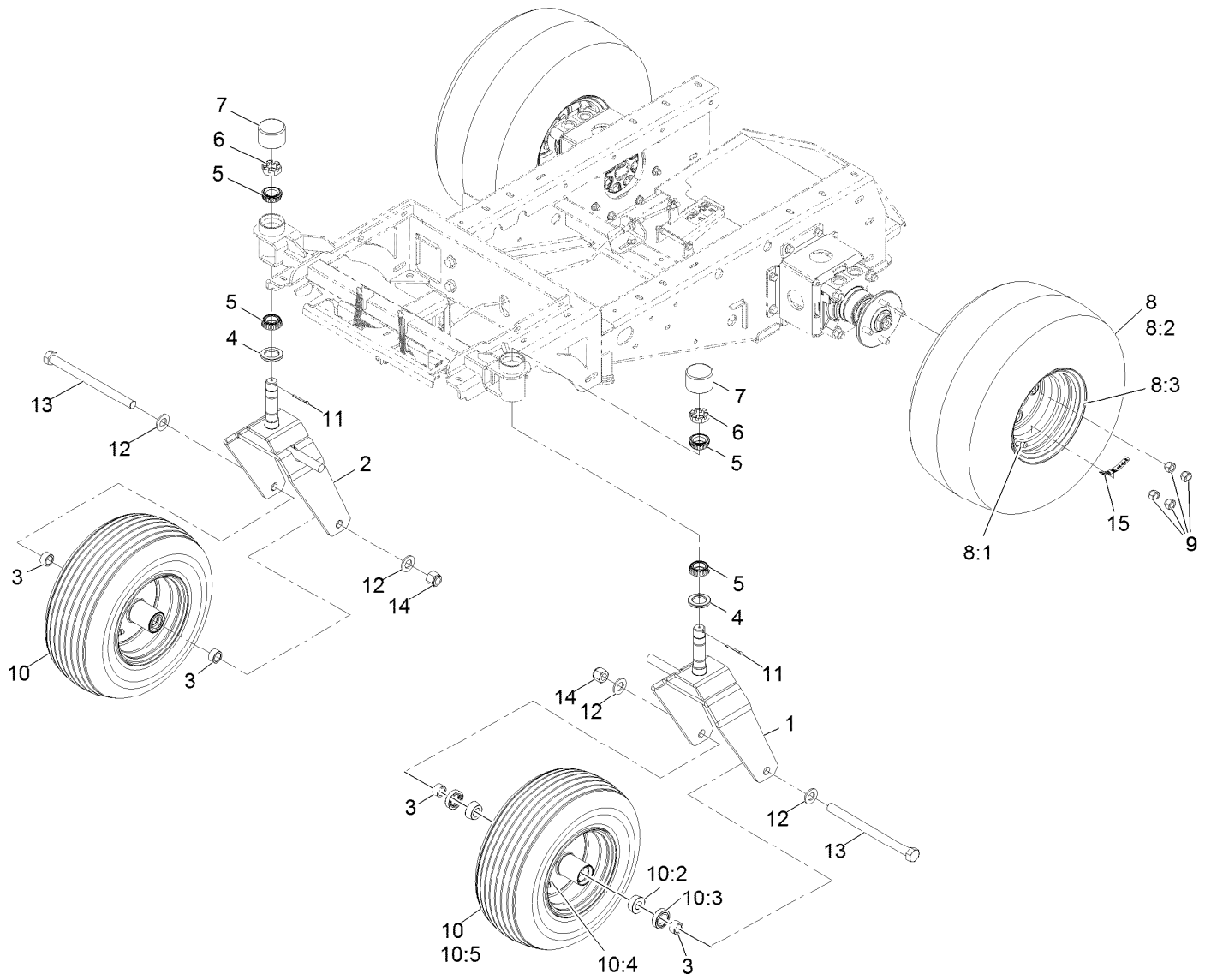

Tire and Wheel Assembly (continued)

<i>Ref.</i>	<i>Part Number</i>	<i>Qty.</i>	<i>Description</i>	<i>Ref.</i>	<i>Part Number</i>	<i>Qty.</i>	<i>Description</i>
1	135-5441-03	1	Caster-Lt [black]	10	135-5974	2	Wheel And Tire
2	135-5446-03	1	Caster-Rt [black]	10:2	1-633585	2	Bearing-Cone, Taper
3	135-5683	4	Spacer-Axle	10:3	103-0063	2	Seal-Caster
4	1-543511	2	Seal-Grease	10:4	5108	1	Valve
5	254-92	4	Cone-Bearing, Outer	10:5	135-5976	1	Tire-Rib
6	1-809082	2	Nut-SHH	11	135-6292	2	Pin-Cotter
7	135-5756	2	Cap-Dust, Rubber	12	3256-28	4	Washer-Flat
8	135-5968	2	Wheel And Tire ASM	13	135-6300	2	Screw-HH
8:1	135-5969	1	Rim-8 X 7, Black	14	3296-51	2	Nut-Lock, NI
8:2	120-6466	1	Tire	15	126-2055	2	Decal-Torque, Wheel Hub
8:3	232-27	1	Stem-Valve				Lug
9	242-50	8	Nut-Lug				

Hopper Assembly

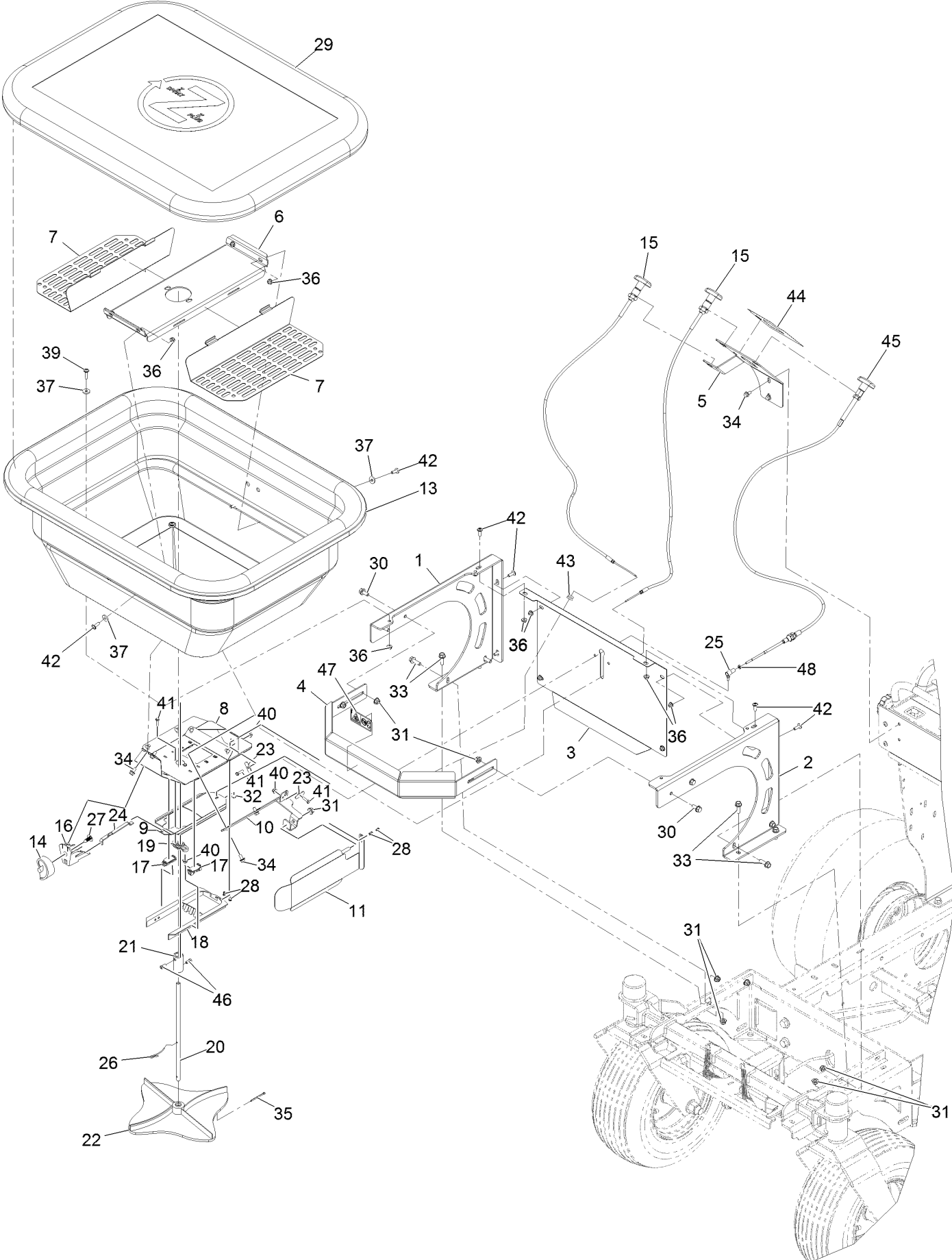

Hopper Assembly (continued)

<i>Ref.</i>	<i>Part Number</i>	<i>Qty.</i>	<i>Description</i>	<i>Ref.</i>	<i>Part Number</i>	<i>Qty.</i>	<i>Description</i>
1	135-5391	1	Side-Hopper, Rt	27	126-0986	1	Clip
2	135-5393	1	Side-Hopper, Lt	28	135-5961	2	Retainer-Cable, Wire
3	135-5571	1	Backshield-Hopper	29	135-6145	1	Cover-Hopper, Large
4	135-5567	1	Bumper-Front, Hopper	30	126-2712	4	Screw-HHF 5/16-18 X 3/4 SS
5	135-5505	1	Mount-Speedometer	31	135-6109	13	Nut-Hex Flange
6	135-5542	1	Pan-Hopper, 220	32	HDW05856	1	Nut,NYL Lock,#10-32,ST/ST 18-8
7	135-5544	2	Screen-Hopper, 220	33	135-6272	8	Screw-HHF
8	135-5572	1	Plate-Base, Hopper	34	135-6280	10	Screw-HHF
9	135-5573	1	Slide-Door, Hopper	35	135-6340	1	Pin-Cotter
10	135-5388	1	Mount-Deflector, Side	36	135-6108	14	Nut-Hex Flange
11	135-5589	1	Deflector-Side, Spreader	37	135-6341	8	Washer
13	135-5985	1	Hopper-220Lb	39	135-7081	4	Screw-Hsbhf
14	126-0988	1	Dial	40	135-6342	4	Nut-Hex Flange
15	135-5931	2	Cable-Push/Pull	41	135-6356	4	Screw-HH
16	126-0985	1	Mount-Dial	42	135-7080	10	Screw-Hsbhf
17	126-0990	4	Guide-Rate, Gate	43	135-5988	1	Grommet-Rubber
18	126-0991	1	Diffuser	44	135-6279	1	Decal-Hopper Control
19	135-5943	1	Bearing-Flange	45	135-5935	1	Cable-Push/Pull
20	135-5936	1	Shaft-Hopper, 220	46	3241-7	2	Screw-SQH
21	135-5937	1	Coupler-SS	47	135-6725	1	Decal-Dismemberment Hazard
22	135-5954	1	Spinner-Spreader	48	520-0019	1	Nut,Hex Jam Mch Scr,10-32,Sst
23	135-5569	2	Retainer, Cable				
24	135-5965	1	Linkage-Gate, Rate				
25	135-5682	1	Ball Joint-SS				
26	135-5957	1	Wire-Agitator				

Spray System Assembly

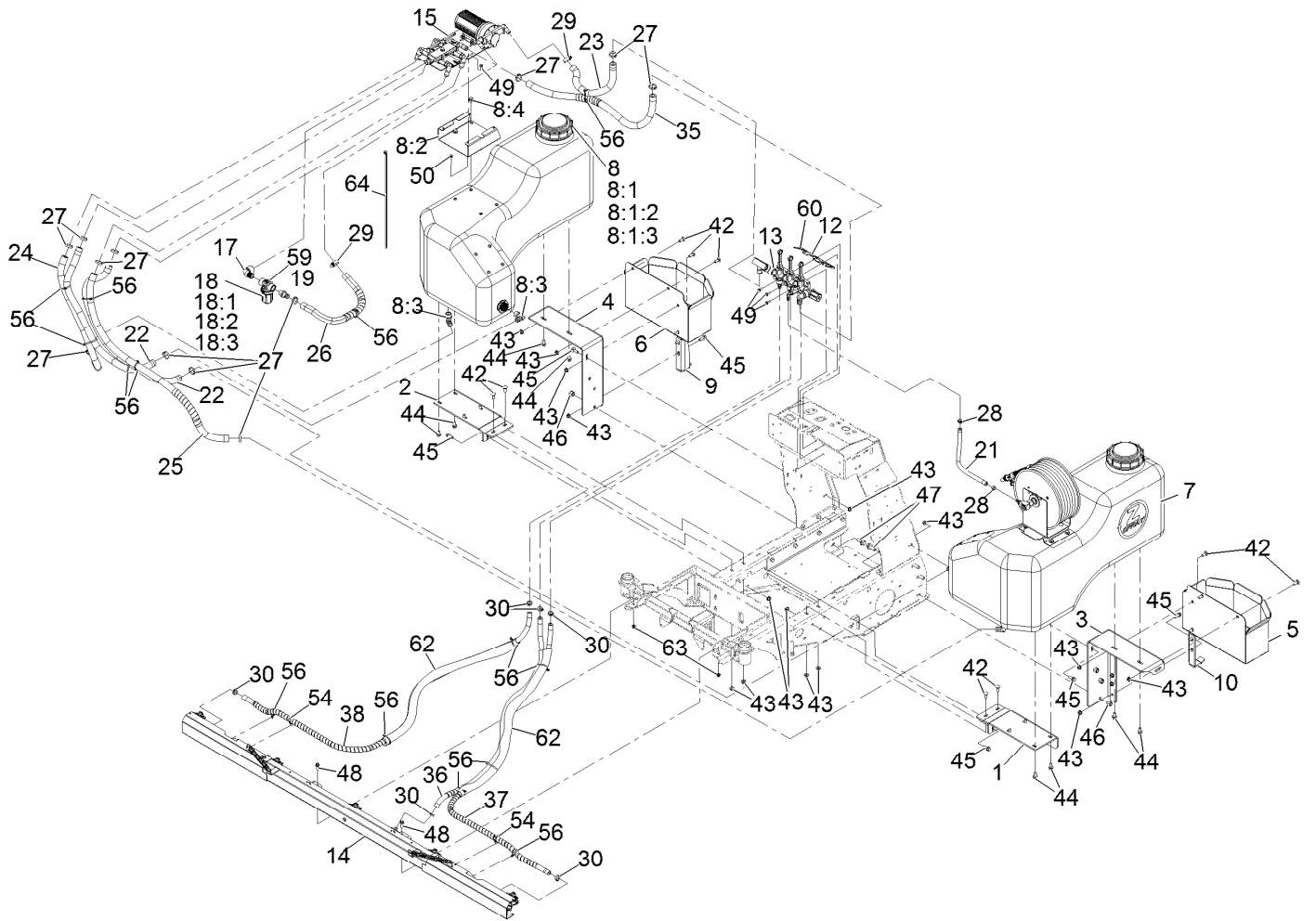

Spray System Assembly (continued)

<i>Ref.</i>	<i>Part Number</i>	<i>Qty.</i>	<i>Description</i>	<i>Ref.</i>	<i>Part Number</i>	<i>Qty.</i>	<i>Description</i>
1	135-5495	1	Mount-Tank, LH Wing	24	135-5326	1	Hose-Spray
2	135-5496	1	Mount-Tank, RH Wing	25	135-5327	1	Hose-Spray, Wrapped
3	135-5395	1	Mount-Box, Lt Fert	26	135-5325	1	Hose-Spray, Wrapped
4	135-5397	1	Mount-Box, Rt Fert	27	135-5890	12	Clamp-Oetiker, 167
5	135-5399	1	Box-Fert, Lt	28	135-5757	2	Clamp-Oetiker, 167
6	135-5402	1	Box-Fert, Rt	29	2412-129	2	Clamp-Hose
7		1	ASM-Tank, Hose Reel ●	30	135-5692	6	Clamp-Oetiker, 167
8		1	ASM-Tank, Rt ●	35	135-6480	1	Hose-Spray, Wrapped
8:1	135-5918	1	ASM-Tank, Rt	36	135-5294	1	Hose-Spray, Wrapped
8:1:2	135-5916	1	Cap-Tank, Spray	37	135-5295	1	Hose-Spray, Wrapped
8:1:3	126-4393	2	Fitting-Bulkhead	38	135-5296	1	Hose-Spray, Wrapped
8:2	135-5546	1	Platform, Liquid Valve Mount	42	126-0980	12	Screw-Carriage 3/8-16 X 1 SS
8:3	135-5772	2	Fitting-Elbow, 90	43	135-6110	22	Nut-Hex Flange
8:4	135-7096	4	Screw-HHF	44	135-6274	12	Screw-HHF
9	135-5408	1	Bracket-Anti-Tip, Rt	45	135-6208	10	Screw-HHF
10	135-5406	1	Bracket-Anti-Tip, Lt	46	HDW14426	6	Nut, 1/2-13,NYL INS,ST/ST,18-8
12	135-5570	1	Bracket-Manifold	47	135-6207	6	Screw-HHF
13		1	ASM-Manifold ●	48	135-6272	2	Screw-HHF
14		1	ASM-Boom ●	49	135-6221	7	Screw-HHF
15		1	ASM, Liquid Valve ●	50	135-6108	4	Nut-Hex Flange
17	132-7706	1	Elbow-90DEG	54	32180-030	2	Clip-Tie
18	135-5765	1	Strainer-Inline	56	3290-378	14	Tie-Cable
18:1	126-7195	1	Bowl-Strainer	59	135-6424	1	Decal-Cap, Strainer
18:2	126-2272	1	Gasket-Head, Line Strainer	60	135-6285	1	Decal-Valve, Boom
18:3	135-5766	1	Screen-Strainer, 50 Mesh	62	135-6484	2	Guard-Mesh
19	41257	1	Hosebarb	63	135-6109	2	Nut-Hex Flange
21	135-5321	1	Hose-Spray	64	3290-379	3	Tie-Cable
22	135-6163	2	Hose-Spray				
23	135-5324	1	Hose-Spray				

● Not serviced separately

Hose Reel Tank Assembly

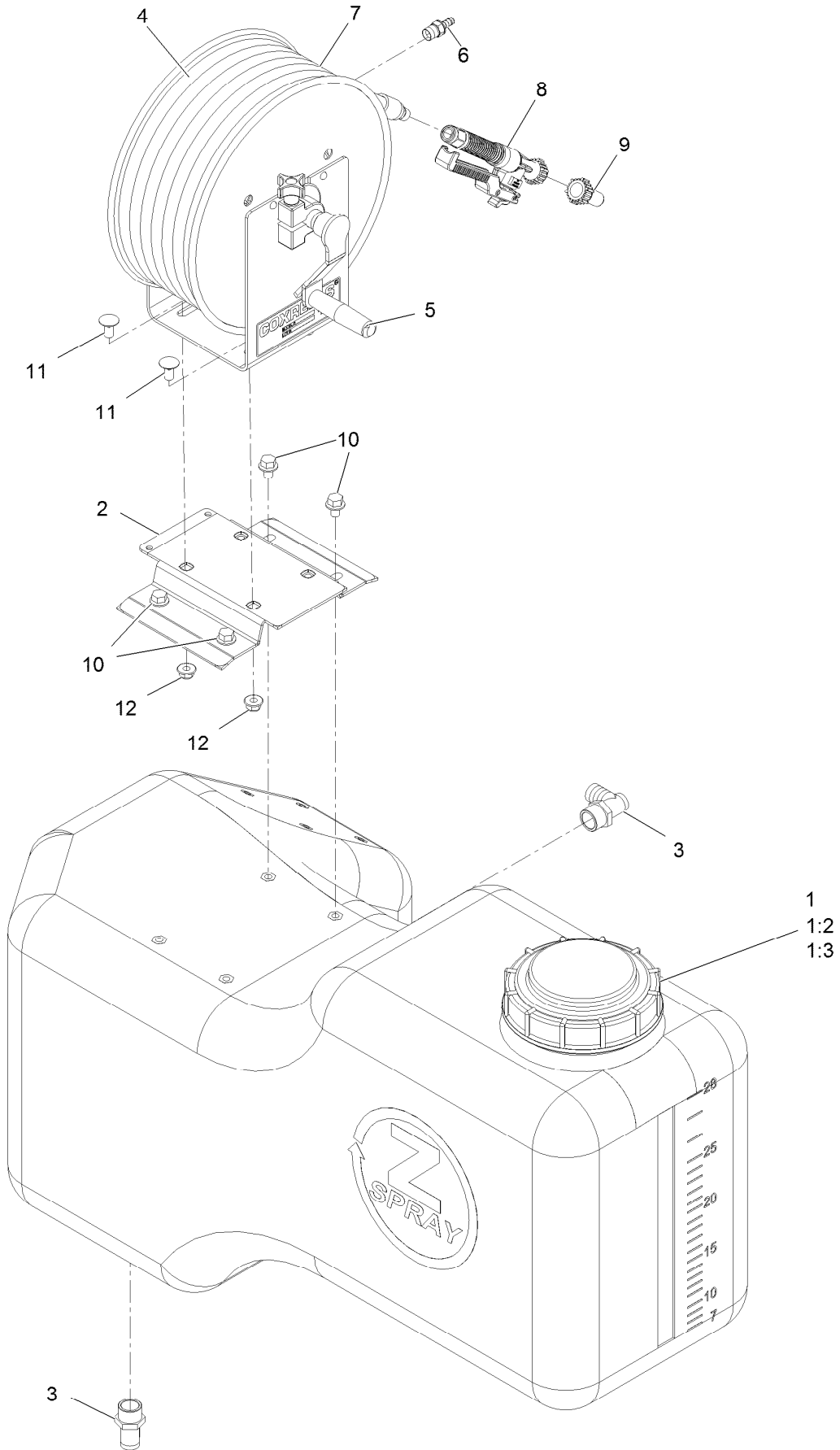

Hose Reel Tank Assembly (continued)

<i>Ref.</i>	<i>Part Number</i>	<i>Qty.</i>	<i>Description</i>	<i>Ref.</i>	<i>Part Number</i>	<i>Qty.</i>	<i>Description</i>
1	135-5917	1	ASM-Tank, Lt	7	135-5794	1	Hose-Spray, 75'
1:2	135-5916	1	Cap-Tank, Spray	8	135-5773	1	Gun-Spray, Spot
1:3	126-4393	2	Fitting-Bulkhead	9	135-5778	1	Tip-Spray, #12 Spot
2	135-5497	1	Mount-Reel, Hose	10	135-7096	4	Screw-HHF
3	135-5772	2	Fitting-Elbow, 90	11	135-6271	4	Screw-Carriage
4	135-5787	1	Reel-Hose	12	135-6110	4	Nut-Hex Flange
5	135-6011	1	Crank-Reel	13	135-5757	1	Clamp-Oetiker, 167 ●
6	1-513200	2	Fitting, Male				

● Not illustrated

Manifold Assembly

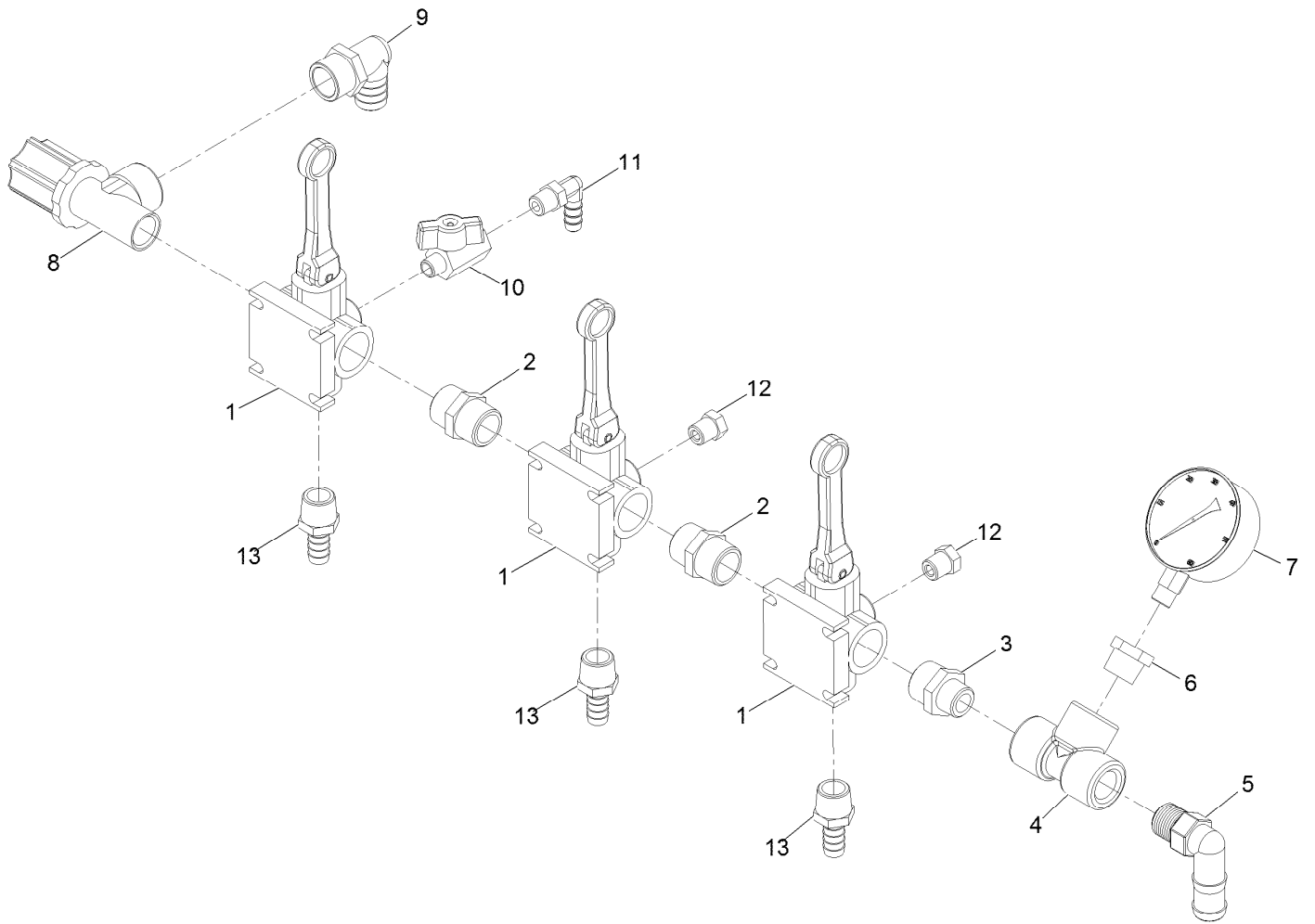

Manifold Assembly (continued)

<i>Ref.</i>	<i>Part Number</i>	<i>Qty.</i>	<i>Description</i>	<i>Ref.</i>	<i>Part Number</i>	<i>Qty.</i>	<i>Description</i>
1	135-5721	3	Valve-Directo	8	135-5736	1	Valve-Throttle
2	135-5741	2	Fitting-Nipple	9	135-5772	1	Fitting-Elbow, 90
3	135-5742	1	Fitting-Nipple	10	135-5737	1	Valve-Chrome, 1/4
4	94-7100	1	Tee	11	135-5745	1	Fitting-Elbow, 90
5	92-8557	1	Elbow-90	12	135-5735	2	Plug-Valve
6	135-5743	1	Fitting-Reducer	13	120-8671	3	Fitting-Hosebarb
7	135-5740	1	Gauge				

Spray Boom Assembly (continued)

<i>Ref.</i>	<i>Part Number</i>	<i>Qty.</i>	<i>Description</i>	<i>Ref.</i>	<i>Part Number</i>	<i>Qty.</i>	<i>Description</i>
1	135-5409	1	Boom-Center	11	138-2751	1	Fitting-Tee, Barb
2	135-5415	1	Boom-Wing, Rt	12	135-6310	2	Screw-HH
3	135-5419	1	Boom-Wing, Lt	13	135-6110	4	Nut-Hex Flange
4	135-5790	2	Body-Nozzle, Right	14	135-6806	2	Nut-Hex Flange
5	135-5789	1	Body-Nozzle, Center	15	126-0702	2	Screw-CARR
6	135-5788	2	Body-Nozzle, Left	16	1126	6	Washer-Flat
7	135-5781	5	Cap-Nozzle	17	135-7106	1	Hose-Spray
7:1	40998	1	Seat-Gasket	18	135-7105	2	Hose-Spray
8	135-5791	5	Tip-Spray	20	135-5692	6	Clamp-Oetiker, 167
9	135-5780	2	Spring-Extension				
10	126-3943	5	Strainer-Nozzle, 50M 5PSI Check				

Liquid Valve Assembly

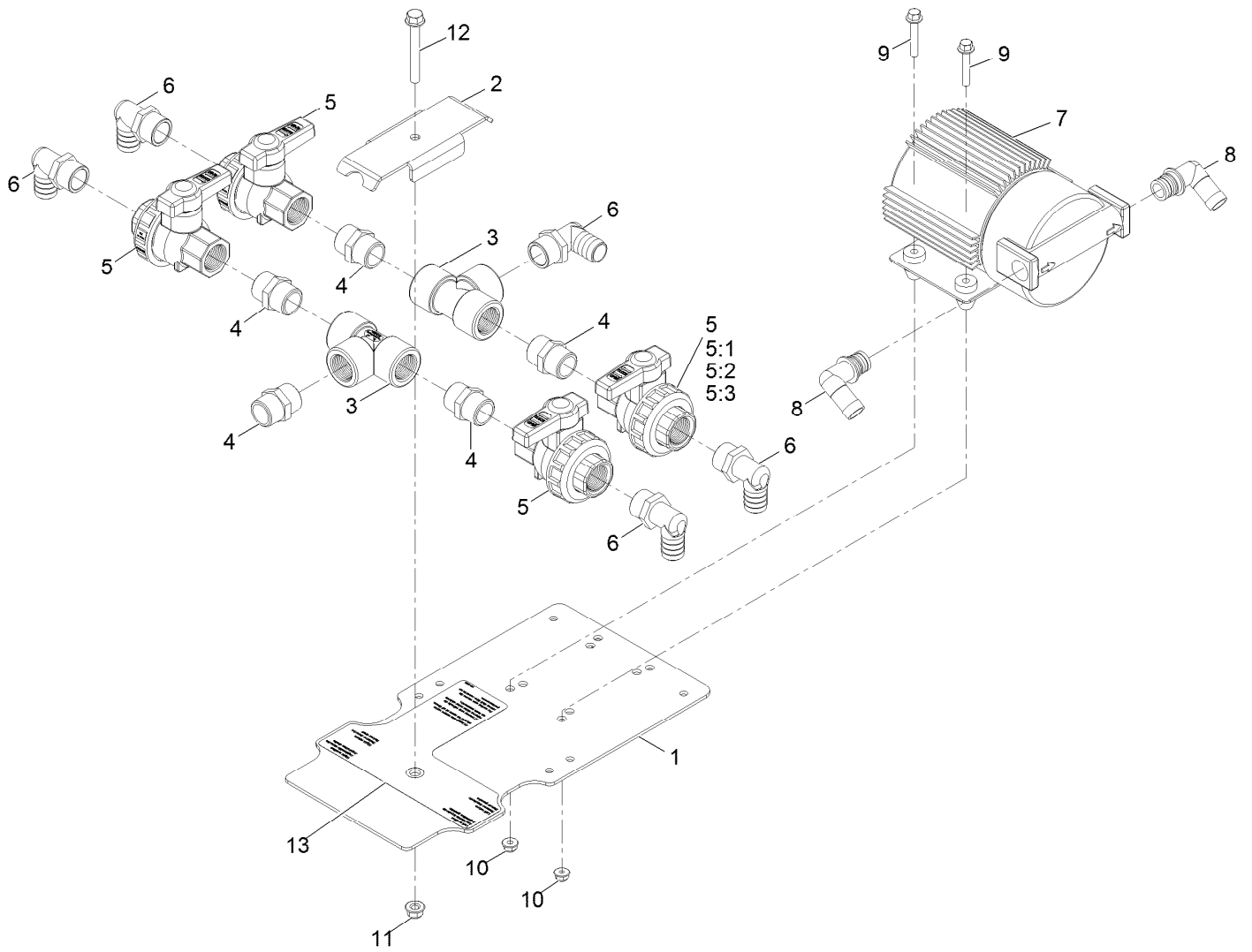

Liquid Valve Assembly (continued)

<i>Ref.</i>	<i>Part Number</i>	<i>Qty.</i>	<i>Description</i>	<i>Ref.</i>	<i>Part Number</i>	<i>Qty.</i>	<i>Description</i>
1	135-5491	1	Mount-Plate, Liquid Valve	6	135-5772	5	Fitting-Elbow, 90
2	135-5504	1	Plate-Clamp, Liquid Valve Fittings	7	135-6001	1	Pump-7.0 GPM
3	135-6004	2	Fitting-Tee	8	135-6003	2	Fitting-Elbow, 3/4Qd X 3/4Barb
4	135-5741	5	Fitting-Nipple	9	135-6320	4	Screw-HHF
5	135-6002	4	Valve-Union, 3/4	10	135-6108	4	Nut-Hex Flange
5:1	135-6006	1	O-Ring	11	135-6109	1	Nut-Hex Flange
5:2	135-6007	1	Ring-Valve, Union 3/4	12	135-6323	1	Screw-HHF
5:3	135-6008	1	Adapter-Uv, 3/4	13	135-6420	1	Decal-Valve, Tank

Fuel Assembly

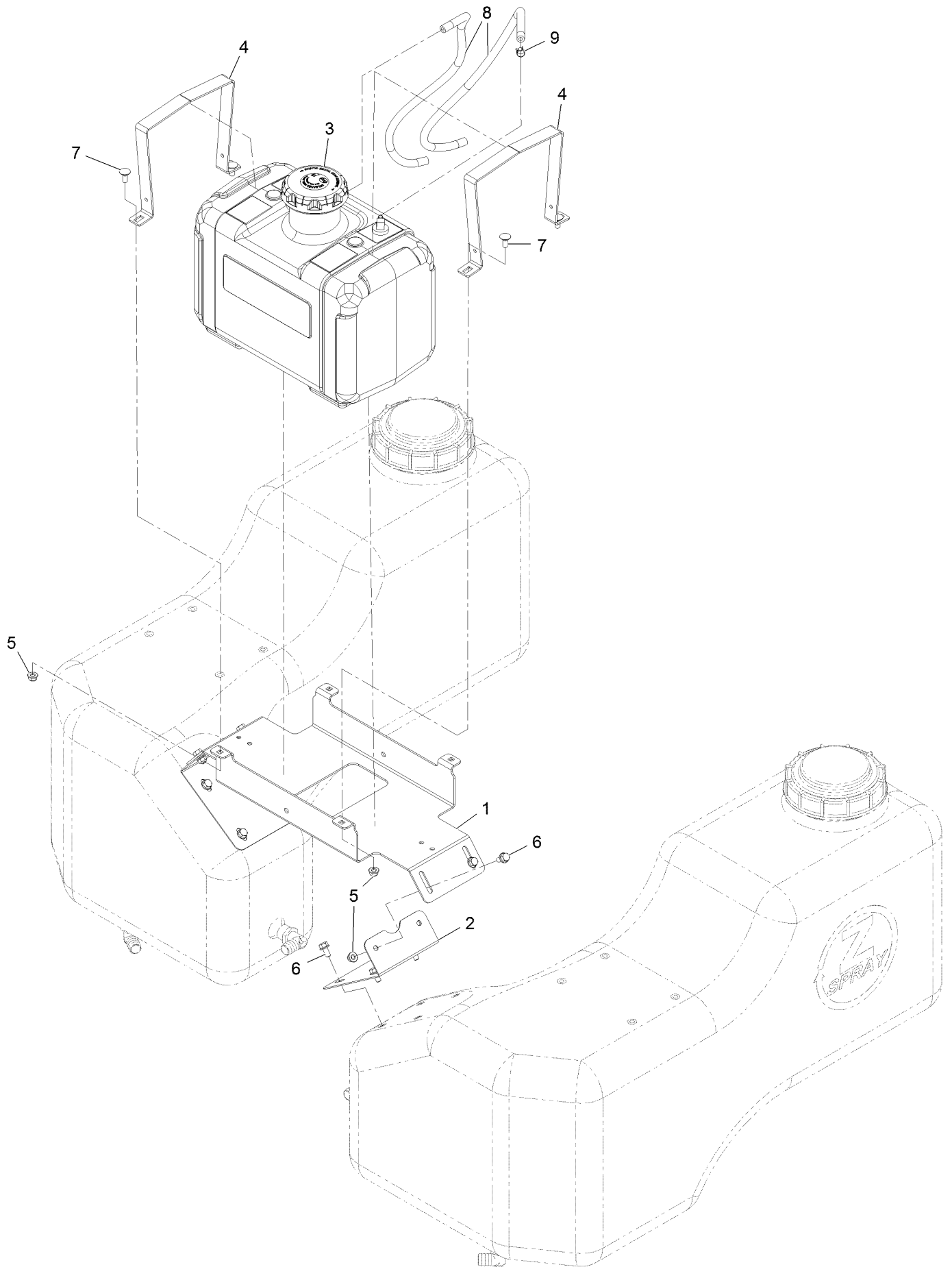

Fuel Assembly (continued)

<i>Ref.</i>	<i>Part Number</i>	<i>Qty.</i>	<i>Description</i>	<i>Ref.</i>	<i>Part Number</i>	<i>Qty.</i>	<i>Description</i>
1	135-7209	1	Mount, Gas Tank	6	135-7086	12	Screw-HHF
2	135-5555	2	Bracket-Support, Gas Tank	7	126-0695	4	Screw-CARR
3	135-7172	1	ASM-Tank, 5 Gal.	8	109-1395	2	Hose-Fuel Line 27"
4	135-7211	2	Strap, Gas Tank	9	2412-98	1	Clamp-Hose
5	135-6109	8	Nut-Hex Flange				

Engine Assembly

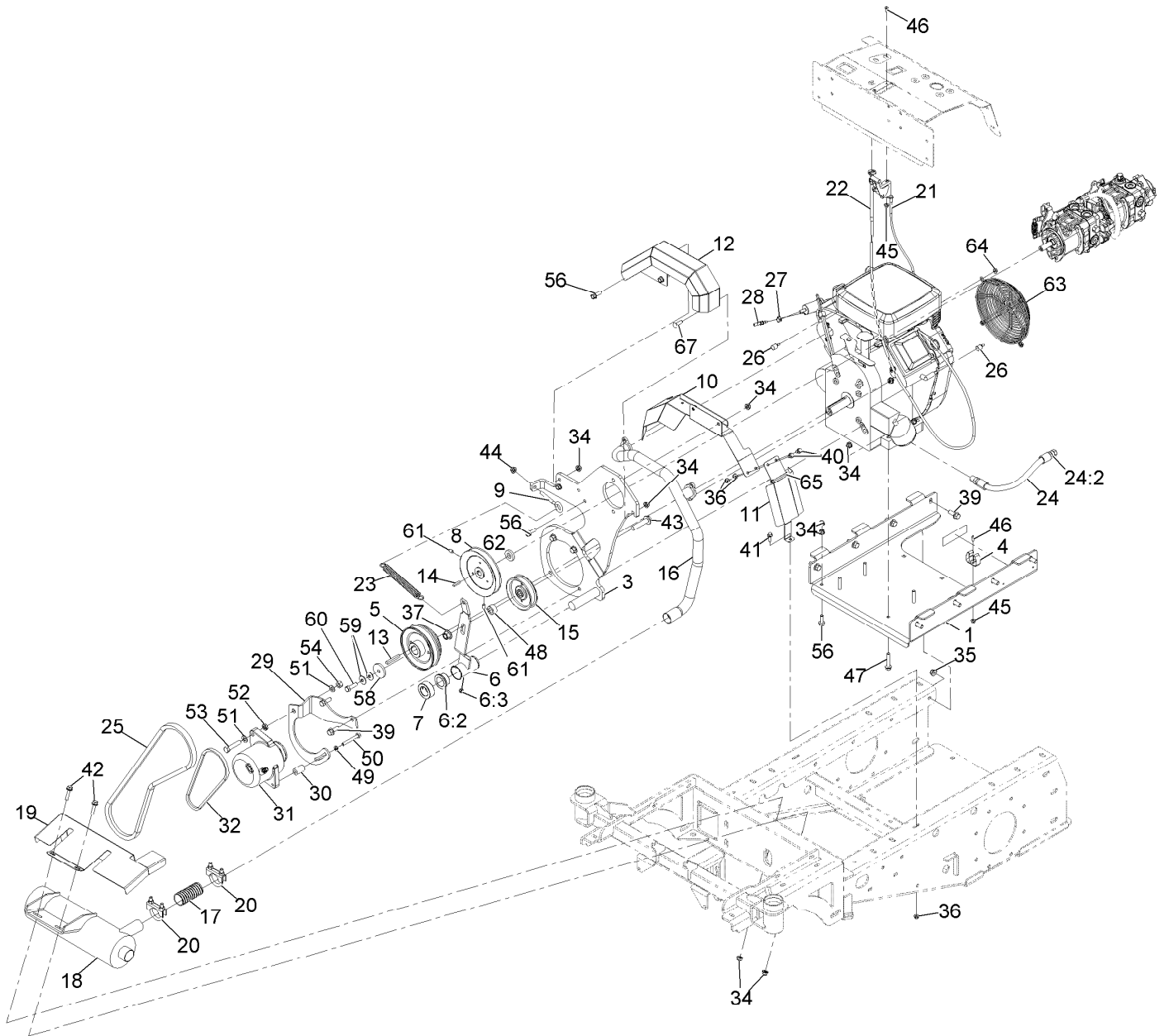

Engine Assembly (continued)

<i>Ref.</i>	<i>Part Number</i>	<i>Qty.</i>	<i>Description</i>	<i>Ref.</i>	<i>Part Number</i>	<i>Qty.</i>	<i>Description</i>
1	135-5492	1	Tray-Engine	31	135-6057	1	Alternator
3	135-5453-03	1	Bracket-Engine, Pump [black]	32	135-6613	1	Belt-V, 3L240
4	135-5661	1	Holder-Tool, Clip	34	135-6109	13	Nut-Hex Flange
5	135-6394	1	Pulley-Double	35	135-6110	8	Nut-Hex Flange
6	135-5669	1	Arm-Tension, ASM	36	135-6108	3	Nut-Hex Flange
6:2	256-132	2	Bushing-Flange	37	99-5107	1	Nut-Lock
6:3	302-63	1	Fitting-Grease, Zerk	39	135-6208	12	Screw-HHF
7	135-5382	1	Collar	40	135-6280	2	Screw-HHF
8	135-5663	1	Pulley-Drive, Pump	41	135-6221	1	Screw-HHF
9	135-5667	1	Bolt-Eye	42	135-6261	2	Screw-HHF
10	135-5565	1	Guard, Lower Muffler	43	3234-46	1	Screw-HHF
11	135-5566	1	Guard, Lower Muffler	44	104-8300	1	Nut-HF, NI
12	135-5552	1	Guard-Pulley	45	135-6342	3	Nut-Hex Flange
13	103-4177	1	Key	46	135-6374	3	Screw-HSBH
14	1-807272	1	Key	47	135-5779	4	Screw-HHF
15	135-5662	1	Pulley-Idler, Flat	48	116-2959	1	Spacer
16	135-5670	1	Manifold-Exhaust	49	3253-4	1	Washer-Lock
17	135-5658	1	Tube-Exhaust, Flex	50	120-9642	1	Screw-HH
18	135-5685	1	Muffler	51	33095-00	2	Washer-Flat
19	135-5568	1	Shield-Heat, Muffler	52	110-9346	1	Nut-Hex
20	2112-11	2	Clamp-Muffler	53	33115-050	1	Screw-HH
21	135-5260	1	Cable-Throttle	54	33025-00	1	Nut-Lock, NI
22	135-5707	1	Cable-Choke	56	135-6272	5	Screw-HHF
23	135-5780	1	Spring-Extension	58	110-9981	1	Washer-Plain
24	135-5365	1	ASM, Oil Drain Hose W/Plug	59	3290-340	2	Washer-Belleville
24:2	AU218-774	1	Plug	60	3211-5	1	Screw-HH
25	135-5664	1	Belt-V	61	3246-17	2	Setscrew-HSH
26	135-5677	2	Tube-Heat Shrink, 1/2	62	1-323539	1	Spacer
27	2412-98	1	Clamp-Hose	63	135-6554	1	Guard-Wire, Vanguard
28	135-5678	1	Barb-Fuel	64	33003-00	4	Nut-HF
29	135-5929	1	Bracket-Alternator	65	3290-378	1	Tie-Cable
30	135-5930	1	Tube-Support, Alternator	67	HDW17294	1	Bolt, Carriage, 5/16-18X1, ST/ST 18-8

Hydraulic Assembly

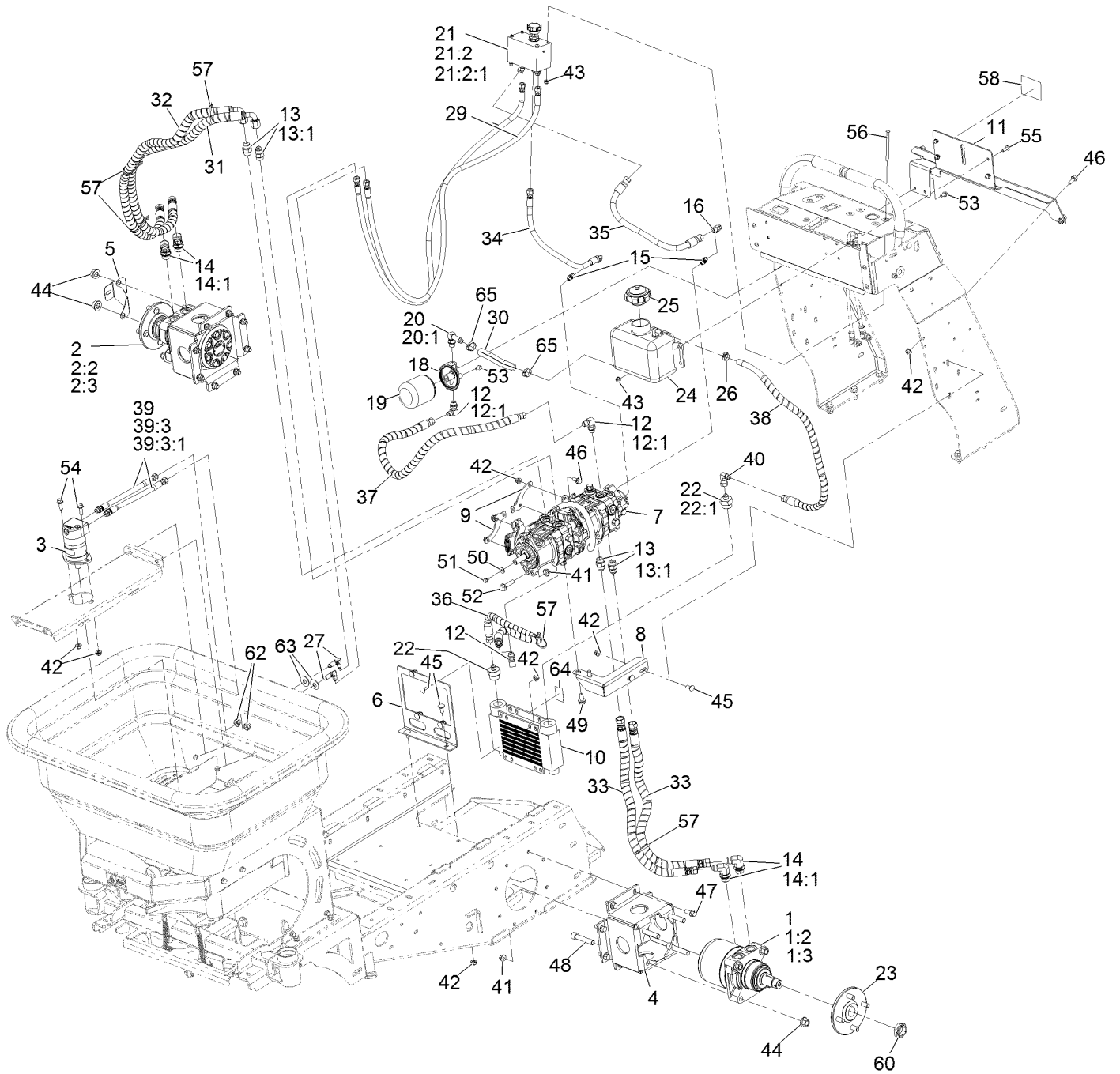

Hydraulic Assembly (continued)

<i>Ref.</i>	<i>Part Number</i>	<i>Qty.</i>	<i>Description</i>	<i>Ref.</i>	<i>Part Number</i>	<i>Qty.</i>	<i>Description</i>
1	135-5230	1	Motor, LH Wheel	27	135-5796	2	Fitting-Elbow, 90
1:2	3257-42	1	Key-Woodruff 5/16 X 1	29	135-5357	2	Hose ASM, HYD HP
1:3	103-6994	1	Seal Kit	30	109-5577	1	Hose-Hydraulic
2	135-5231	1	Motor, RH Wheel	31	135-5458	1	Hose ASM, HYD HP
2:2	3257-42	1	Key-Woodruff 5/16 X 1	32	135-5460	1	Hose ASM, HYD HP
2:3	103-6994	1	Seal Kit	33	135-5457	2	Hose ASM, HYD HP
3	135-5243	1	Motor-Hydraulic, Spreader	34	135-5360	1	Hose ASM, HYD HP
4	135-5448-03	2	Mount-Motor, Wheel [black]	35	135-5361	1	Hose ASM, HYD LP
5	135-5574	1	Bracket-Hopper, Speedometer Sensor	36	135-5384	1	Hose ASM, HYD LP
6	135-6483	1	Mount-Cooler	37	135-5385	1	Hose ASM, HYD LP
7	135-5665	1	Pump-Tandem	38	135-5456	1	Hose ASM, HYD LP
8	135-5551	1	Bracket-Support, Hydro Pump	39	135-5359	2	Hose ASM, HYD HP
9	135-5558	2	Extension, Hydro Pump	39:3		1	Fitting-Straight, Rigid ●
10	135-5679	1	Cooler-Oil	39:3:1	237-42	1	O-Ring
11	135-5550	1	Mount, Hydraulic Tank And Filter	40	AU218-980	1	Fitting-Swivel, 90 DEG
12	103-1802	3	Fitting-Elbow, 90 DEG	41	135-6110	18	Nut-Hex Flange
12:1	237-42	1	O-Ring	42	135-6109	18	Nut-Hex Flange
13	353-388	4	Fitting-Straight	43	135-6108	8	Nut-Hex Flange
13:1	237-79	1	O-Ring	44	99-5107	8	Nut-Lock 1/2-13
14	353-426	4	Fitting-90 DEG	45	126-0695	8	Screw-CARR
14:1	237-80	1	O-Ring	46	126-2712	8	Screw-HHF 5/16-18 X 3/4 SS
15	353-545	2	Fitting-Straight	47	135-6208	16	Screw-HHF
16	135-5680	1	Fitting-90 Swivel	48	3274-71	8	Screw-HSH
18	104-7836	1	Filter-Head	49	135-6274	2	Screw-HHF
19	135-5695	1	Filter-Hydraulic	50	135-6273	1	Washer
20	109-6449	1	Fitting-Elbow, 90	51	81-1280	1	Screw-HHF
20:1	237-42	1	O-Ring	52	135-6278	2	Screw-HHF
21	135-5256	1	Manifold-Hopper, W/Out Relief	53	135-6280	2	Screw-HHF
21:2	353-212	1	Fitting-Elbow, 45 DEG	54	135-6272	2	Screw-HHF
21:2:1	237-42	1	O-Ring	55	135-7080	4	Screw-Hsbhf
22	AU218-5044	2	Adapter-Straight	56	135-6385	4	Screw-HSBH
22:1	237-81	1	O-Ring	57	3290-378	6	Tie-Cable
23	135-5684	2	Hub-Wheel	58	135-6398	1	Decal-Oil
24	135-5712	1	Tank-Hydraulic, Plastic	60	116-1399	2	Locknut
25	135-5713	1	Cap-Vented	62	3220-4	2	Nut-Jam
26	135-5757	1	Clamp-Oetiker, 167	63	135-5586	2	Washer-SS, 1.25 OD, .503 ID
				64	106-5517	1	Decal-Warning
				65	135-5692	2	Clamp-Oetiker, 167

● Not serviced separately

Electrical Assembly

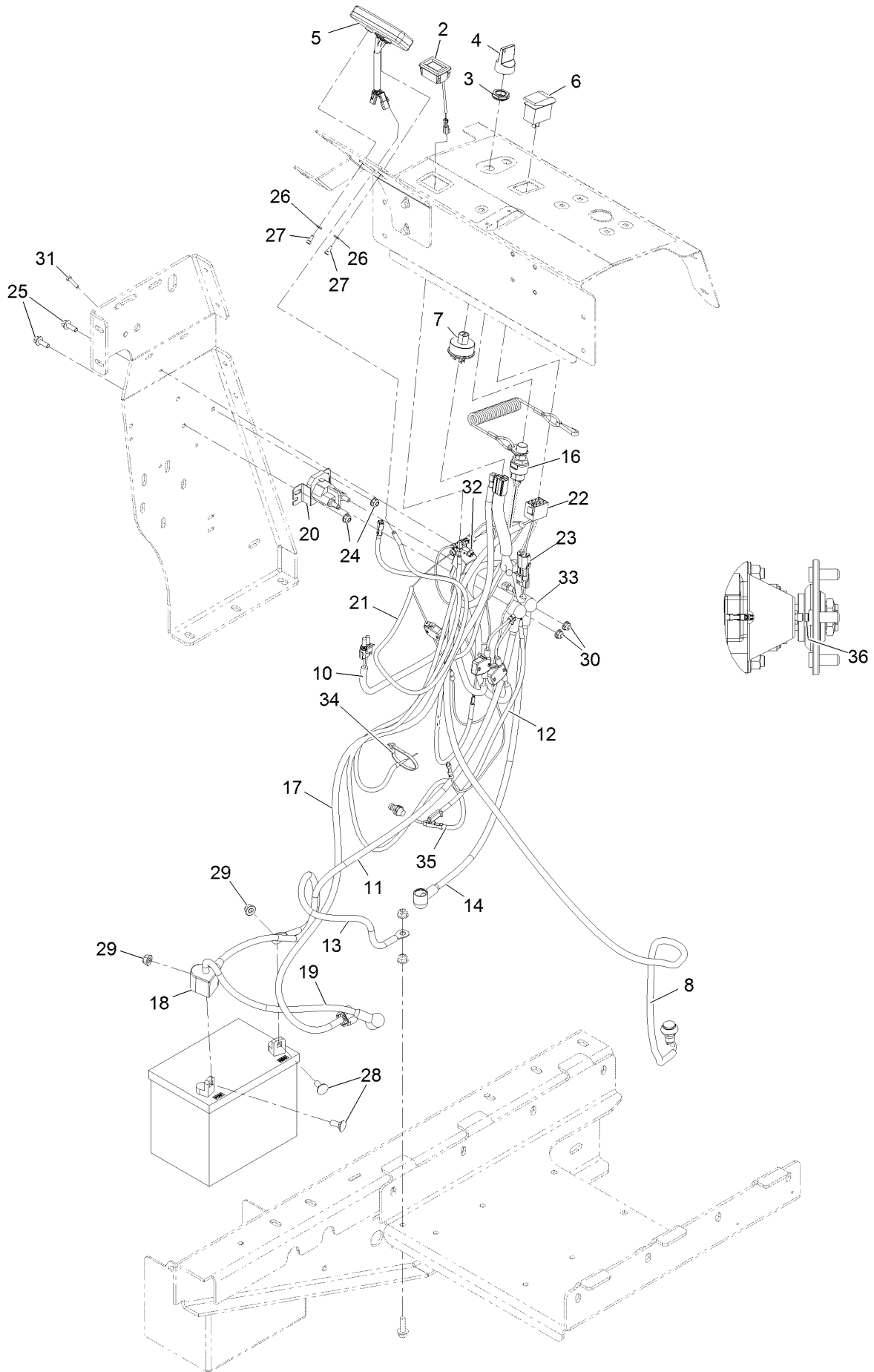

Electrical Assembly (continued)

<i>Ref.</i>	<i>Part Number</i>	<i>Qty.</i>	<i>Description</i>	<i>Ref.</i>	<i>Part Number</i>	<i>Qty.</i>	<i>Description</i>
2	135-5259	1	Meter-Tach/Hour	22	32160-008	1	Connector-Carling, 8F
3	135-5715	1	Nut-Switch, Key	23	32160-072	1	Connector-Wp,2M
4	135-5708	1	Key-Umbrella	24	135-6108	2	Nut-Hex Flange
5	135-8900	1	Head Only, Striker	25	135-6221	2	Screw-HHF
6	100-8469	1	Switch-Rocker	26	126-0759	2	Washer-Flat
7	135-6052	1	Switch-Ignition	27	135-6357	2	Screw-HSH
8	135-6054	1	Switch-Push Button	28	126-0695	2	Screw-CARR
10	135-6113	1	Harness, Main	29	135-6109	2	Nut-Hex Flange
11	135-6114	1	Cable-Positive	30	104-7201	2	Nut-Nyloc 1/4-20 Flg
12	135-6115	1	Wire-Solenoid	31	135-6356	1	Screw-HH
13	135-6116	1	Cable-Ground	32	135-6342	1	Nut-Hex Flange
14	135-6117	1	Cable-Positive	33	1-543393	4	Insulator-Solenoid
16	135-6121	1	Switch-Op	34	3290-378	11	Tie-Cable
17	135-6120	1	Harness, Alternator	35	135-8898	1	Cable-Trail Tech, Sensor
18	135-2304	1	Insulator-Battery	36	135-8903	1	Magnet, Speedometer
19	135-6119	1	Cable-Positive	99	135-7317	1	Manual-User, Striker ●
20	135-6189	1	Solenoid-Starter	99	135-7318	1	Card-Striker, Quick Start ●
21	135-6443	1	Harness-Striker				

● Not illustrated

