

Walker Rider Lawnmowers

ILLUSTRATED PARTS MANUAL

Model MT (20.0 HP)
Model MTL (25.0 HP)
Model MTEFI (26.0 HP)

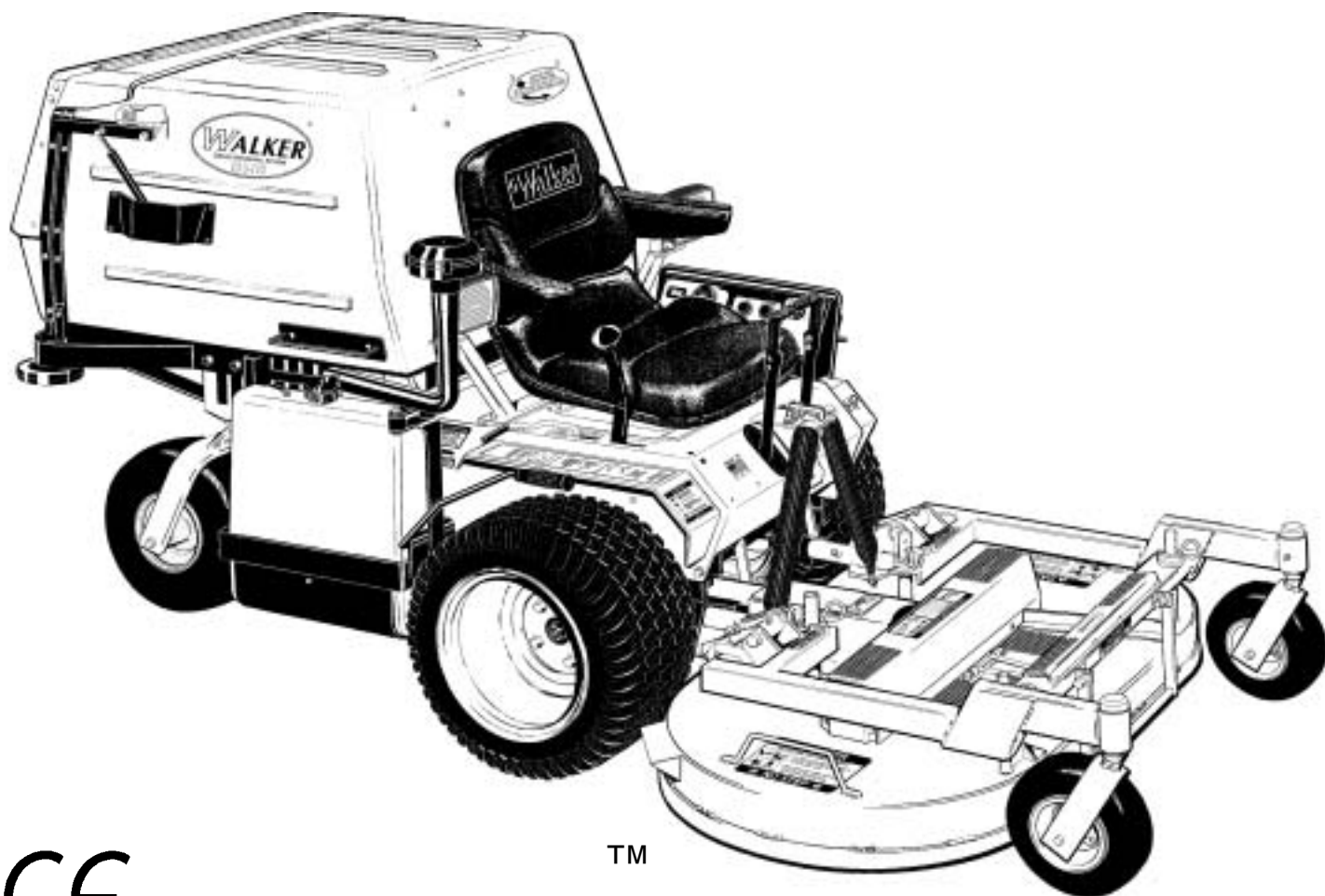

CE

TM

Effective Date:
04-01-04

P/N 8000-10
Price \$5.00

KEY TO ABBREVIATIONS USED IN THIS MANUAL

<i>Abbreviation</i>	<i>What it Represents</i>
° (Dimension)	Degrees (Angle)
" (Dimension)	inches
(-)	Negative (Polarity)
(+)	Positive (Polarity)
AT	All-Terrain
CCW	Counter-clockwise
Conn.	Connector
CW	Clockwise
D	Diameter
DGHS	Deck, Grass Handling System (number refers to size in inches)
DML	Deck, Mulching (number refers to size in inches)
DSD	Deck, Side Discharge (number refers to size in inches)
DU	Garlock (Bearing)
ESNA (Fastener)	Nylon Insert Locknut
FSC	Forward Speed Control
GA	Gauge
gal.	gallon
GHS	Grass Handling System
GR (Fastener)	Grade
HP	Horse Power
HT	Heat-Treated
ID	Identification or Inside Diameter
L	Length
LH	Left Hand (orientated with operator on seat)
LP	Low Profile
mm (Dimension)	millimeters
MS (Fastener)	Machine Screw
NS (as part number)	Item is not sold by Walker Manufacturing
OD	Outside Diameter
oz.	ounce
PFH (Fastener)	Phillips Flat Head
P/N	Part Number
PPH (Fastener)	Phillips Pan Head
PTH (Fastener)	Phillips Truss Head
PTO	Power Take-Off
QKS	Quick Slide
qt.	quart
RH	Right Hand (orientated with operator on seat)
SAE (Fastener)	Society of Automotive Engineers
SBH (Fastener)	Socket Button Head (Bolt)
SD	Side Discharge
SFH (Fastener)	Slotted Flat Head
SHC (Fastener)	Socket Head Cap
SHL (Fastener)	Shoulder (Bolt)
SM (Fastener)	Sheet Metal (Screw)
S/N	Serial Number
Spg.	Spring
SQH (Fastener)	Square Head
SS (Fastener)	Stainless Steel
ST (Fastener)	Self-Tapping (Screw)
Term.	Terminal
V	Volts

NOTE: In some instances, combinations of abbreviations may be used (e.g. PPHMS - Phillips Pan Head Machine Screw).

Use only genuine **Walker**[®] replacement parts.

Effective Date 04-01-04

ILLUSTRATED PARTS LIST

<i>Section of Mower Covered</i>	<i>Page</i>	<i>Section of Mower Covered</i>	<i>Page</i>
Decals		Electrical Components	
Tractor Decals	2	Electrical Assembly	
Body / Chassis Assemblies		(MT)	50
Body / Chassis Assembly		(MTL)	52
(GHS Models) MT/MTEFI	4	(MTEFI)	54
(GHS Models) MTL	6	Electrical Assemblies	
Rear Body Assembly		(GHS 7.0 / 9.5 Bushel Components)	56
(GHS Models) MT/MTEFI	8	Electrical Connectors	58
(GHS Models) MTL	10	Options and Kits	
Body Assembly		Power Deck Lift Kit	60
(SD Models) MT/MTEFI	12	Armrest Kit / Touch-Up Paint	62
(SD Models) MTL	14	Comfort Seat / Armrest Kit	64
Tractor Components		Suspension Seat Kit	66
Main Component Power Transmission		Light Kit	68
(GHS Models)	16	Blower Lockout Kit / Case-Hardened Blower	70
(SD Models)	18	Cold Start Kit / Speed Up Kit	72
Engine Group		Power Dump Kit	
(MT)	20	(7.0 Bushel GHS Models Only)	74
(MTL)	22	(9.5 Bushel GHS Models Only)	76
(MTEFI)	24	No Catch Deflector Kit / Tail Weight Kit	78
Radiator Group (MTL)	26	Spread Tail Wheel Axle Kit	80
Hydrostatic Ground Drive Assemblies	28	Tail Wheel Lock Kit	82
Steering Control Assemblies	30	Wide Tail Wheel / All-Terrain Tire Kit &	
Throttle & Choke Control Assembly	32	Tire Chain Set	84
Parking Brake Assembly	34	Maintenance	
GHS Group	36	Lubrication Points	86
GHS Powerfil® Assembly	38	Wiring Schematic	
GHS 7.0 Bushel Catcher &		(MT)	88
Exhaust Deflector Assemblies	40	(MTL)	89
GHS 9.5 Bushel Catcher Assembly	42	(MTEFI)	90
Instrument Panel Assembly		Operator's Notes	92
(MT)	44	Warranty	
(MTL)	46	Limited Warranty	93
(MTEFI)	48		

TRACTOR DECALS

ITEM NO.	PART NO.	DESCRIPTION	LOCATION	NO. REQ'D. GHS	NO. REQ'D SD
Walker Product and Operation Decals					
1	7802	RH Fender	Body, RH Side Near Seat	1	1
2	5856	Made in USA	Body	1	1
3	5803	Walker Manufacturing Logo	Body	1	1
4	5813-1	Powerfil®	7.0 / 9.5 Bushel Catcher, Front	1	0
5	5801	GHS	7.0 / 9.5 Bushel Catcher (one on each side)	2	0
6	5800	Walker Mower (4 x 7-1/2)	Utility Bed (one on each side)	0	2
7	5806	Blade Clutch	Body, RH Side	1	1
Danger Decals Warning Decals Caution Decals					
8	5804	Danger, Rotating Blower Blades	Body Near Body Chute	1	0
9	7818	Warning, Read Manual	Body	1	1
10	6810	Danger, Engine Exhaust	Engine	1	1
11	5868	Danger, Pinch Point	7.0 / 9.5 Bushel Catcher Mounting Frame Assembly (one on each side)	2	0
12	5844-2	Warning, Electric System	Battery Hold-Down Bar	1**	1**
Maintenance Decals					
13	7809	Parking Brake	Body, RH Side below Seat	1	1
14	7820	Body Release Decal	Body, RH Side	1	1
15	7819	Throttle	Body, LH Side	1	1
16	8819	Choke	Body, LH Side	1	1
17	5855	Important, Engine Cooling	Engine	1	1
18	5810-2	Reservoir	Hydrostatic Drives (one on each)	2	2
19	5810-1	Axle Oil Level	Gear Axle Drive Assemblies (one on each)	2	2
20	5819	Blower Maintenance	Blower Housing	1	0
21	6875	PTO Alignment Arrow	Universal Joint Tube Assembly	1	1
22	7827	Oil Level	Jackshaft Support	1	1
23	5874	Push to Release	7.0 / 9.5 Bushel Catcher Safety Latch	1	0
24	8825	Front Body Closure	Rear Cross Member, Body	1	1
25	8821	20 HP	Body	1*	1*
	8822	25 HP	Body	1*	1*
	8822-10	26 HP	Body	1*	1*
26	5869	Removable Screen	7.0 / 9.5 Bushel Catcher Removable Screen	1	0
Option Decals (applied only to units with corresponding Options installed)					
27	7633	Power Dump Switch	Body	1	0
28	8555	Tail Lock Switch	FSC Lever Assembly - Switch Mount Bracket	1	1
29	8654	Power Deck Lift Switch	Body, RH Side	1	1
	8500-8	No Catch Deflector	7.0 / 9.5 Bushel No Catch Deflector, LH Side (Refer to 7.0 / 9.5 Bushel No Catch Deflector Kit Listing)	1	0

* 20 HP Decal is Standard. 25 HP Decal furnished only with 25 HP Engine Upgrade Option.
26 HP Decal furnished only with Optional 26 HP EFI Engine.

** Decal furnished only with MTEFI.

NOTE: All parts requiring decals are shipped with decals applied.

Use only genuine **Walker®** replacement parts.

Effective Date 04-01-04

TRACTOR DECALS

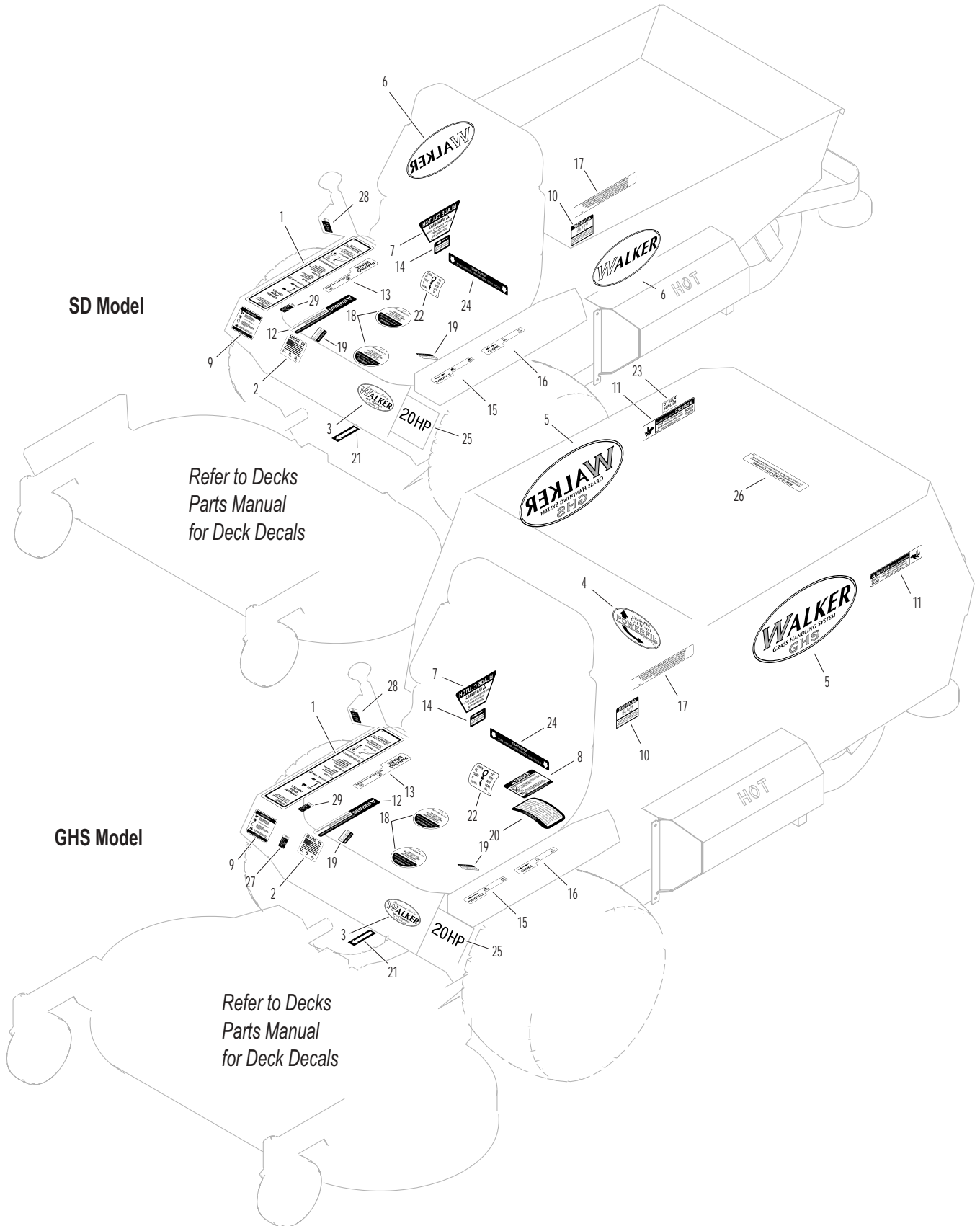

BODY / CHASSIS ASSEMBLY (GHS MODELS) MT/MTEFI

ITEM NO.	PART NO.	DESCRIPTION	NO. REQ'D	ITEM NO.	PART NO.	DESCRIPTION	NO. REQ'D	
Seat Assembly				43	8037-1	Seal, Tail Wheel Axle	2	
1	5103	Seat	1	44	8038-1	Spacer, Tail Wheel Axle	2	
2	7203	Seat Spring Plate	1	45	8037	Bearing Cone (3/4 ID)	4	
3	7223	Compression Spring (1/2 x 1)	2	46	8035	Tail Wheel & Tire Assembly (13 x 5.00-6) (With Bearing Race)	2	
4	7845	Rubber Bumper (1.375 OD x .63)	2		7035-1	Tail Wheel Tire (13 x 5.00-6)	**	
5	7846	Washer (3/8 ID x 1-1/4 OD x 1/8)	2		8036	Wheel & Hub (6 x 3.25) (Includes Item # 41 & Bearing Race)	**	
6	7204	Shoulder Bolt, Seat Mount	2		8037-2	Bearing Race	**	
7	7440-5	Shock Mount (1-1/4 x 2)	2		47	8768-2	Seal	2
Rear Bumper Assembly (GHS Models Only)*				48	8038	Tail Wheel Axle (3/4 x 10-3/8)	1	
8	7516	7.0 / 9.5 Rear Bumper	1	49	7070	Wheel & Tire Assembly (18 x 9.5-8)	2	
9	7516-5	Catcher Pivot Bushing	2		7070-1	Drive Tire (18 x 9.5-8)	**	
10	5162	Roller Wheel (5" Rubber)	2		5070-4	Wide Wheel (8 x 7)	**	
11	7517-2	Catcher Pivot Plate	2	50	8300-3	Chassis Frame (T/5.0 gal.)	1	
Body Assembly					8300-12	Chassis Frame (EFI/5.0 gal.)	1	
12	NS	Body ID Plate	1	Fasteners				
13	5845	Rubber Bumper (1.50 OD x 1.25)	4		F002	10-24 Keps Nut	2	
14	8118	Heat Deflector	1		F004	1/4-20 Keps Nut	2	
15	7422	Panel Guard	1		F005	1/4-20 ESNA Nut	1	
16	5989-4	Dome Plug (3/8)	4		F009	5/16-18 Whiz Locknut	11	
17	5989-3	Dome Plug (5/16)	2		F012	3/8-16 Keps Nut	8	
18	7146	13mm Ball Stud	2		F013	3/8-16 Whiz Locknut	2	
19	7844	Rubber Bumper (1.25 OD x .25)	1		F014	3/8-16 ESNA Nut	4	
20	7147	Spring Clip	2		F020	5/16-18 ESNA Nut	1	
21	7145	Gas Spring Assembly (Includes Items # 18 & 20)	1		F025	10-24 x 3/8 PPHMS	2	
22	7222	Extension Spring (1-1/4 x 3)	1		F029	1/4-20 x 1/2 Hex Bolt	2	
23	7383-1	Body Latch Hook	1		F031	1/4-20 x 5/8 Hex Bolt	1	
24	7854	Plastic Tip, Red	1		F034	5/16-18 x 3/4 Hex Bolt	2	
25	5989-9	Dome Plug (1/4)	10		F038	3/8-16 x 1 Hex Bolt	6	
26	8100	Front Body / T	1		F040	3/8-16 x 1-1/2 Hex Bolt	2	
	8100-10	Front Body / EFI	1		F042	3/8-16 x 2-1/4 Hex Bolt	2	
27	5180	Edge Molding, Lever Opening	2		F050	1/4 SAE Washer	1	
28	5989-55	Dome Plug (1/2)	1		F051	3/8 SAE Washer	2	
29	5989-5	Dome Plug (7/16)	1		F059	3/8 Wave Spring Washer	2	
Tilt-Up Latch Assembly					F093	5/16-18 x 1 Hex Bolt	1	
30	5847	Plastic Tip	1		F113	5/16-18 x 5/16 Set Screw	2	
31	5744-20	Spring Arm, Tilt-Up Latch	1		F151	3/8-16 x 7/8 Hex Bolt	2	
32	5744-10	Spring Pivot Bushing	1		F157	1/2-20 x 1-1/4 Wheel Lug Bolt	8	
33	5744-15	Compression Spring (3/8 x 5/8)	1		F205	5/16-18 x 1/4 Set Screw, Knurl Point	2	
34	5744-13	Mount Angle, LH	1		F206	#2 x 3/16 Drive Pin	2	
35	5744-12	Hook, Tilt-Up Latch	1		F218	7/16 Split Lock Washer	2	
36	5744-14	Mount Angle, RH	1		F219	7/16-14 x 1-1/4 Hex Bolt	2	
Chassis Assembly					F227	3/8 x 1-1/4 x 1/8 Plastic Washer	2	
37	5267-1	Retainer Collar (1") (Includes Item # F113)	1		F241	.375 x .875 x .10 Washer	4	
38	5270-1	Pivot Bearing	2		F341	Coil Roll Pin (7/64 x 9/16)	1	
39	5842-1	Washer, Axle Spacer	1		F342	5/16 Conical Washer	2	
40	7420	Tail Wheel Fork	1	* Rear Bumper Assembly for SD Models is not shown here. Refer to BODY ASSEMBLY (SD MODELS) MT/MTEFI , Page 12.				
41	5830-3	Grease Fitting (45 Degree)	2	** Service Part Only				
42	8039	Nut, Tail Wheel Axle	2					

Use only genuine **Walker**[®] replacement parts.

Effective Date 04-01-04

BODY / CHASSIS ASSEMBLY (GHS MODELS) MT/MTEFI

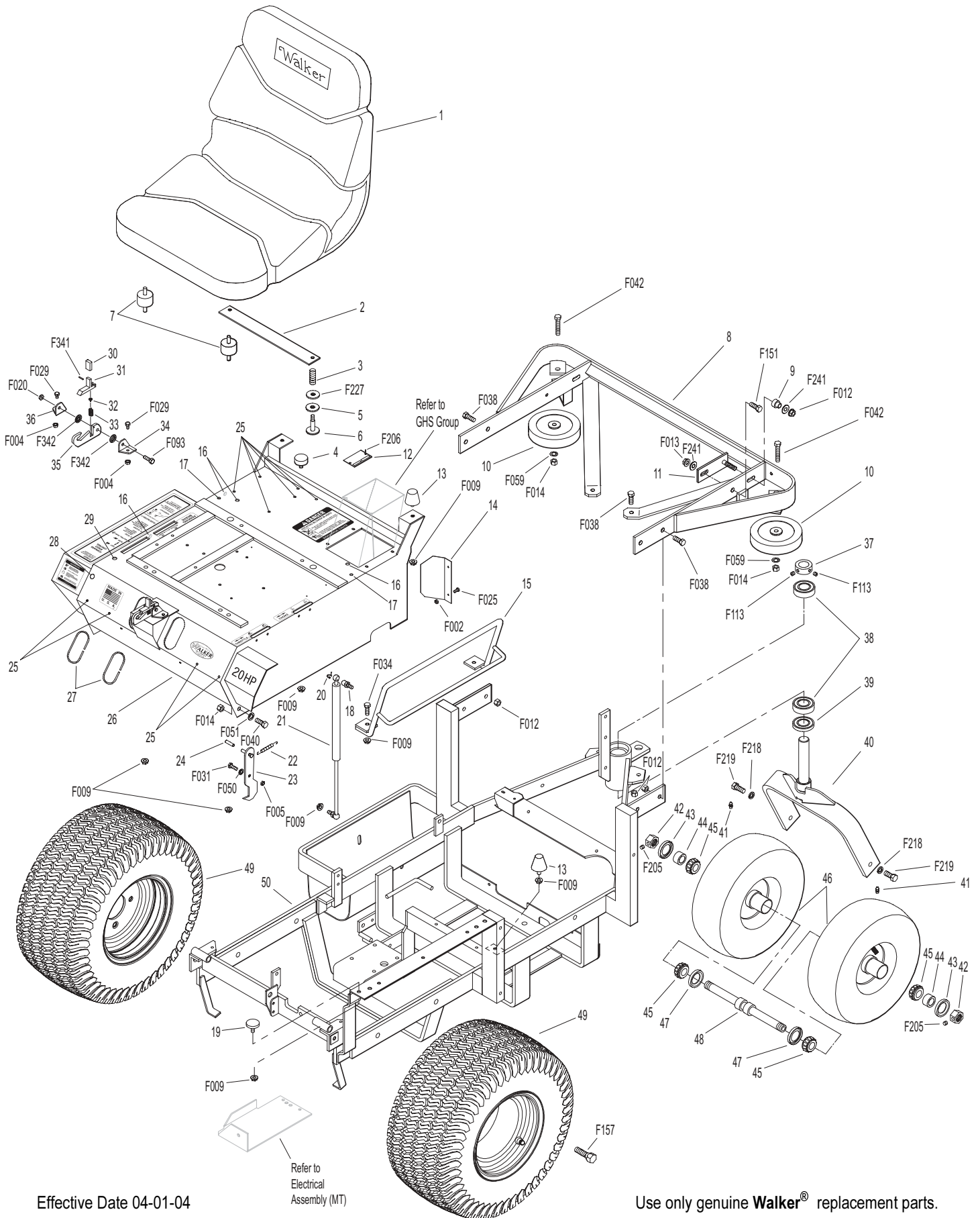

Effective Date 04-01-04

Refer to
Electrical
Assembly (MT)

Use only genuine Walker® replacement parts.

BODY / CHASSIS ASSEMBLY (GHS MODELS) MTL

ITEM NO.	PART NO.	DESCRIPTION	NO. REQ'D	ITEM NO.	PART NO.	DESCRIPTION	NO. REQ'D
Seat Assembly				43	8037-1	Seal, Tail Wheel Axle	2
1	5103	Seat	1	44	8038-1	Spacer, Tail Wheel Axle	2
2	7203	Seat Spring Plate	1	45	8037	Bearing Cone (3/4 ID)	4
3	7223	Compression Spring (1/2 x 1)	2	46	8035	Tail Wheel & Tire Assembly (13 x 5.00-6) (With Bearing Race)	2
4	7845	Rubber Bumper (1.375 OD x .63)	2		7035-1	Tail Wheel Tire (13 x 5.00-6)	**
5	7846	Washer (3/8 ID x 1-1/4 OD x 1/8)	2		8036	Wheel & Hub (6 x 3.25) (Includes Item # 41 & Bearing Race)	**
6	7204	Shoulder Bolt, Seat Mount	2		8037-2	Bearing Race	**
7	7440-5	Shock Mount (1-1/4 x 2)	2	47	8768-2	Seal	2
Rear Bumper Assembly (GHS Models Only)*				48	8038	Tail Wheel Axle (3/4 x 10-3/8)	1
8	7516-7	7.0 / 9.5 Rear Bumper	1	49	7070	Wheel & Tire Assembly (18 x 9.5-8)	2
9	7516-5	Catcher Pivot Bushing	2		7070-1	Drive Tire (18 x 9.5-8)	**
10	5162	Roller Wheel (5" Rubber)	2		5070-4	Wide Wheel (8 x 7)	**
11	7517-2	Catcher Pivot Plate	2	50	8300-4	Chassis Frame	1
Body Assembly				Fasteners			
12	NS	Body ID Plate	1	F002	10-24 Keps Nut		2
13	5845	Rubber Bumper (1.50 OD x 1.25)	4	F004	1/4-20 Keps Nut		2
14	8118	Heat Deflector	1	F005	1/4-20 ESNA Nut		1
15	7422	Panel Guard	1	F009	5/16-18 Whiz Locknut		11
16	5989-4	Dome Plug (3/8)	4	F012	3/8-16 Keps Nut		8
17	5989-3	Dome Plug (5/16)	2	F013	3/8-16 Whiz Locknut		2
18	7146	13mm Ball Stud	2	F014	3/8-16 ESNA Nut		4
19	7844	Rubber Bumper (1.25 OD x .25)	1	F020	5/16-18 ESNA Nut		1
20	7147	Spring Clip	2	F025	10-24 x 3/8 PPHMS		2
21	7145	Gas Spring Assembly (Includes Items # 18 & 20)	1	F029	1/4-20 x 1/2 Hex Bolt		2
22	7222	Extension Spring (1-1/4 x 3)	1	F031	1/4-20 x 5/8 Hex Bolt		1
23	7383-1	Body Latch Hook	1	F034	5/16-18 x 3/4 Hex Bolt		2
24	7854	Plastic Tip, Red	1	F038	3/8-16 x 1 Hex Bolt		6
25	5989-9	Dome Plug (1/4)	10	F040	3/8-16 x 1-1/2 Hex Bolt		2
26	8100-1	Front Body	1	F042	3/8-16 x 2-1/4 Hex Bolt		2
27	5180	Edge Molding, Lever Opening	2	F050	1/4 SAE Washer		1
28	5989-55	Dome Plug (1/2)	1	F051	3/8 SAE Washer		2
29	5989-5	Dome Plug (7/16)	1	F059	3/8 Wave Spring Washer		2
Tilt-Up Latch Assembly				F093	5/16-18 x 1 Hex Bolt		1
30	5847	Plastic Tip	1	F113	5/16-18 x 5/16 Set Screw		2
31	5744-20	Spring Arm, Tilt-Up Latch	1	F151	3/8-16 x 7/8 Hex Bolt		2
32	5744-10	Spring Pivot Bushing	1	F157	1/2-20 x 1-1/4 Wheel Lug Bolt		8
33	5744-15	Compression Spring (3/8 x 5/8)	1	F191	3/8 x 1-1/2 x 3/16 Washer		2
34	5744-13	Mount Angle, LH	1	F205	5/16-18 x 1/4 Set Screw, Knurl Point		2
35	5744-12	Hook, Tilt-Up Latch	1	F206	#2 x 3/16 Drive Pin		2
36	5744-14	Mount Angle, RH	1	F218	7/16 Split Lock Washer		2
Chassis Assembly				F219	7/16-14 x 1-1/4 Hex Bolt		2
37	5267-1	Retainer Collar (1") (Includes Item # F113)	1	F227	3/8 x 1-1/4 x 1/8 Plastic Washer		2
38	5270-1	Pivot Bearing	2	F241	.375 x .875 x .10 Washer		4
39	5842-1	Washer, Axle Spacer	1	F341	Coil Roll Pin (7/64 x 9/16)		1
40	7420	Tail Wheel Fork	1	F342	5/16 Conical Washer		2
41	5830-3	Grease Fitting (45 Degree)	2	* Rear Bumper Assembly for SD Models is not shown here. Refer to BODY ASSEMBLY (SD MODELS) MTL , Page 14.			
42	8039	Nut, Tail Wheel Axle	2	** Service Part Only			

Use only genuine **Walker**[®] replacement parts.

Effective Date 04-01-04

BODY / CHASSIS ASSEMBLY (GHS MODELS) MTL

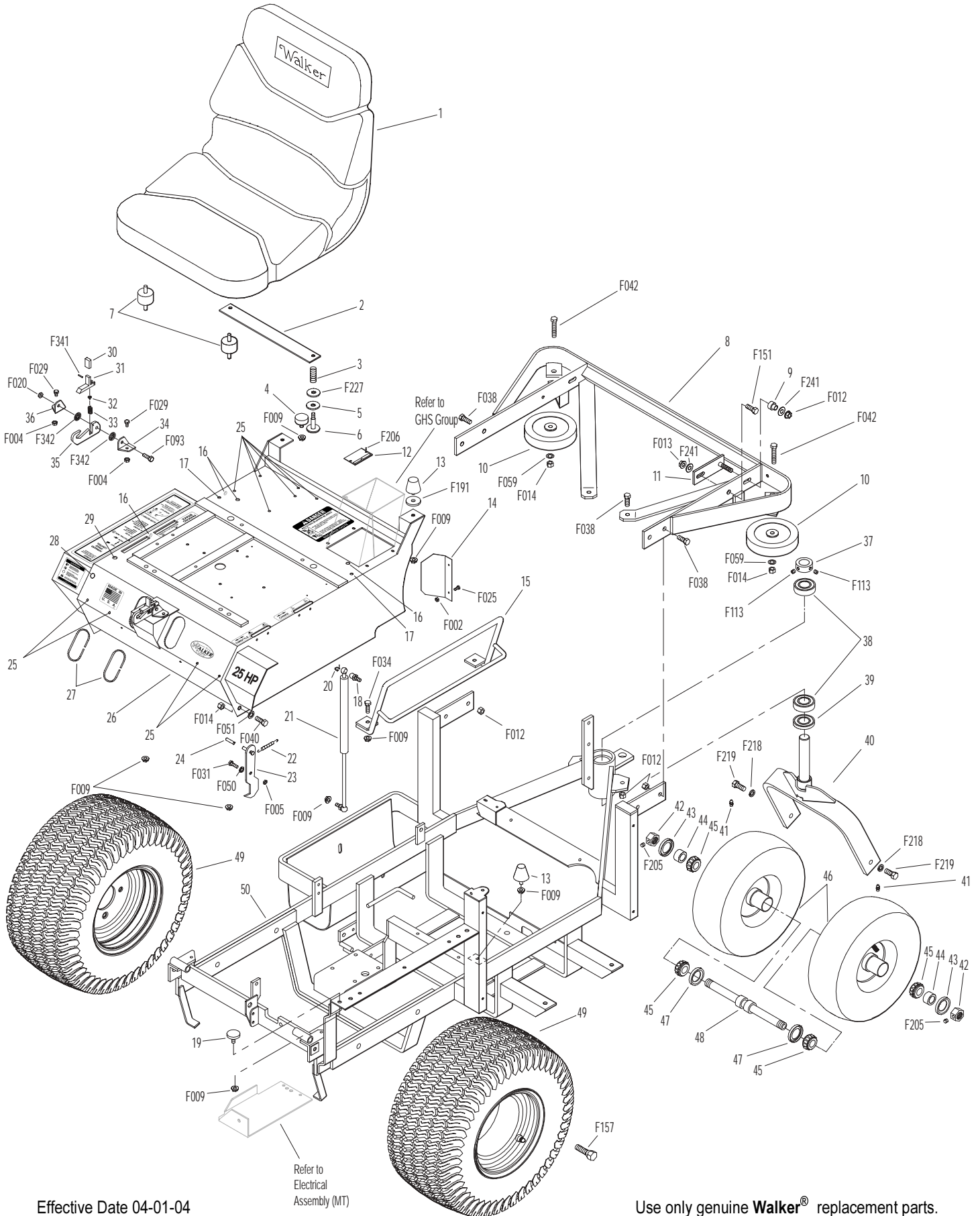

Effective Date 04-01-04

Refer to
Electrical
Assembly (MT)

Use only genuine Walker® replacement parts.

REAR BODY ASSEMBLY (GHS MODELS) MT/MTEFI

ITEM NO.	PART NO.	DESCRIPTION	NO. REQ'D	ITEM NO.	PART NO.	DESCRIPTION	NO. REQ'D
Rear Body Assembly (GHS Models)				Fasteners			
1	7190-3	Insulation Foam Pad (5 x 20)	1	F002		10-24 Keps Nut	14
2	8082	Heat Shield	1	F004		1/4-20 Keps Nut	5
3	8515-10	Catcher Reinforcing Plate	2	F009		5/16-18 Whiz Locknut	2
4	8515-3	Catcher Support Frame	1	F025		10-24 x 3/8 PPHMS	8
5	7190-2	Insulation Foam Pad, RH	1	F026		10-24 x 1/2 PPHMS	5
6	7190-1	Insulation Foam Pad, LH	1	F027		10-24 x 5/8 PPHMS	1
7	7145	Gas Spring Assembly (Includes Items # 9 & 10)	1	F031		1/4-20 x 5/8 Hex Bolt	2
8	8389-2	Splash Guard with Mat	1	F032		1/4-20 x 3/4 Hex Bolt	1
9	7147	Spring Clip	2	F085		3/16 Rivet Backup Washer	2
10	7146	13mm Ball Stud	2	F178		1/4 x 1 Fender Washer	1
11	8105-1	Rear Body Panel	1	F390		1/4-20 x 7/8 Carriage Bolt	2
12	8389-12	Rubber Mat (3 x 3)	1				

NOTE: Rear Bumper Assembly for GHS Models is not shown here. Refer to **BODY / CHASSIS ASSEMBLY (GHS MODELS) MT/MTEFI**, Page 4.

REAR BODY ASSEMBLY (GHS MODELS) MT/MTEFI

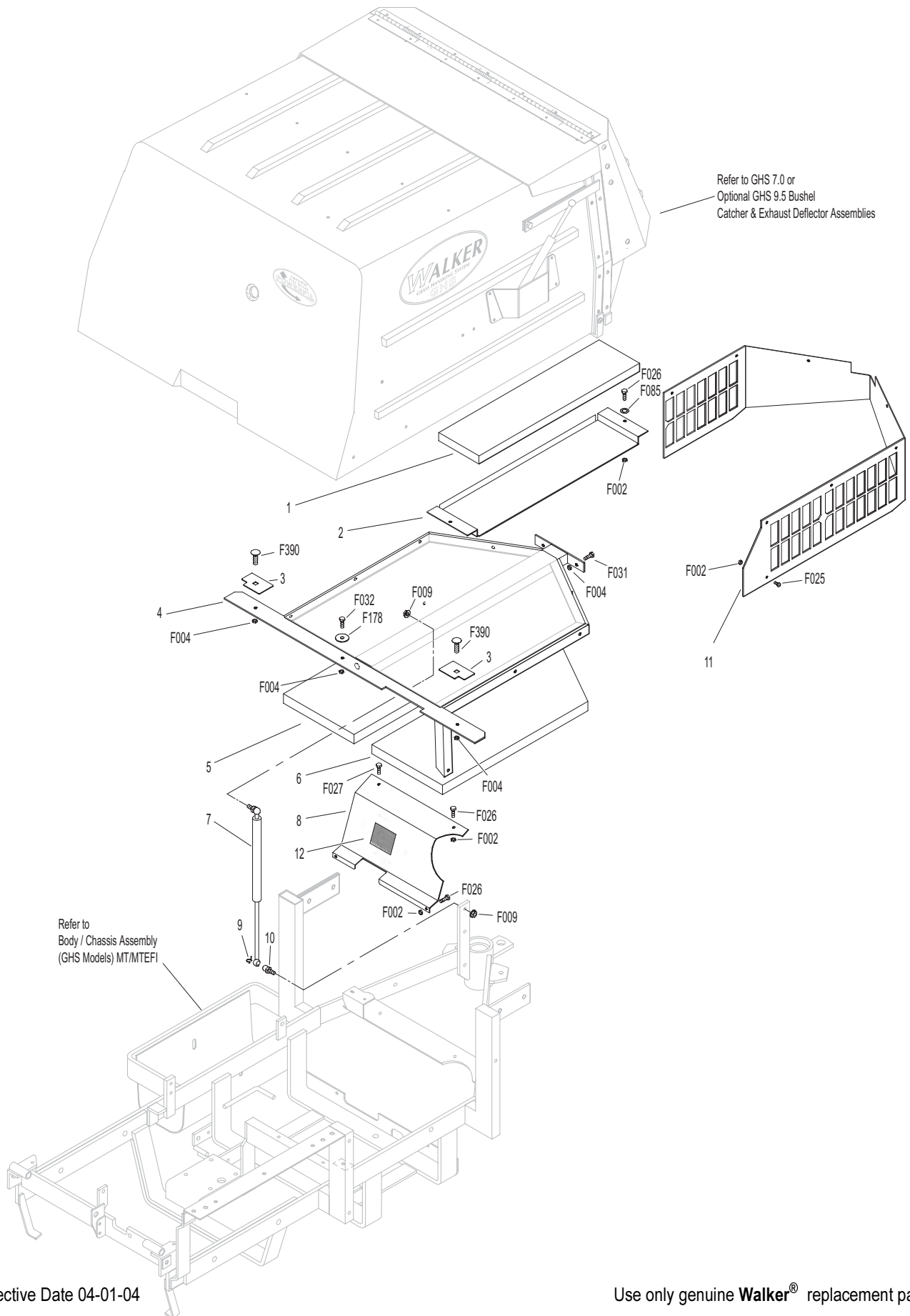

Effective Date 04-01-04

Use only genuine Walker® replacement parts.

REAR BODY ASSEMBLY (GHS MODELS) MTL

ITEM NO.	PART NO.	DESCRIPTION	NO. REQ'D	ITEM NO.	PART NO.	DESCRIPTION	NO. REQ'D
Rear Body Assembly (GHS Models)				Fasteners			
1	8515-10	Catcher Reinforcing Plate	2	F002		10-24 Keps Nut	10
2	8515-4	Catcher Support Frame	1	F004		1/4-20 Keps Nut	5
3	7190-2	Insulation Foam Pad, RH	1	F009		5/16-18 Whiz Locknut	2
4	7190-1	Insulation Foam Pad, LH	1	F025		10-24 x 3/8 PPHMS	6
5	7145	Gas Spring Assembly (Includes Items # 7 & 8)	1	F026		10-24 x 1/2 PPHMS	3
6	8389-3	Splash Guard	1	F027		10-24 x 5/8 PPHMS	1
7	7147	Spring Clip	2	F031		1/4-20 x 5/8 Hex Bolt	2
8	7146	13mm Ball Stud	2	F032		1/4-20 x 3/4 Hex Bolt	3
9	8105-15	Rear Body Panel	1	F178		1/4 x 1 Fender Washer	1

NOTE: Rear Bumper Assembly for GHS Models is not shown here. Refer to **BODY / CHASSIS ASSEMBLY (GHS MODELS) MTL**, Page 6.

BODY ASSEMBLY (SD MODELS) MT/MTEFI

ITEM NO.	PART NO.	DESCRIPTION	NO. REQ'D	ITEM NO.	PART NO.	DESCRIPTION	NO. REQ'D
Utility Bed Assembly				Fasteners			
1	8650-10	Bed Liner (21.5 x 27.5)	1	F002		10-24 Keps Nut	16
2	8650-2	Utility Bed	1	F009		5/16-18 Whiz Locknut	2
3	7190-2	Insulation Foam Pad, RH	1	F012		3/8-16 Keps Nut	6
4	7190-1	Insulation Foam Pad, LH	1	F013		3/8-16 Whiz Locknut	4
Rear Bumper Assembly (SD Models)				F014		3/8-16 ESNA Nut	2
5	7153-3	Cover Plate	1	F025		10-24 x 3/8 PPHMS	8
6	7145	Gas Spring Assembly (Includes Items # 7 & 8)	1	F026		10-24 x 1/2 PPHMS	3
7	7147	Spring Clip	2	F027		10-24 x 5/8 PPHMS	1
8	7146	13mm Ball Stud	2	F038		3/8-16 x 1 Hex Bolt	6
9	7521	Rear Bumper	1	F040		3/8-16 x 1-1/2 Hex Bolt	2
10	5162	Roller Wheel (5" Rubber)	2	F042		3/8-16 x 2-1/4 Hex Bolt	2
11	8105-1	Rear Body Panel	1	F051		3/8 SAE Washer	4
12	8389-2	Splash Guard W/Mat	1	F059		3/8 Wave Spring Washer	2
13	8389-12	Rubber Mat (3 x 3)	1	F128		10-24 x 3/8 PTHMS	4

NOTE: Refer to **BODY / CHASSIS ASSEMBLY (GHS MODELS) MT/MTEFI**, Page 4 for all common parts used on both models.

BODY ASSEMBLY (SD MODELS) MT/MTEFI

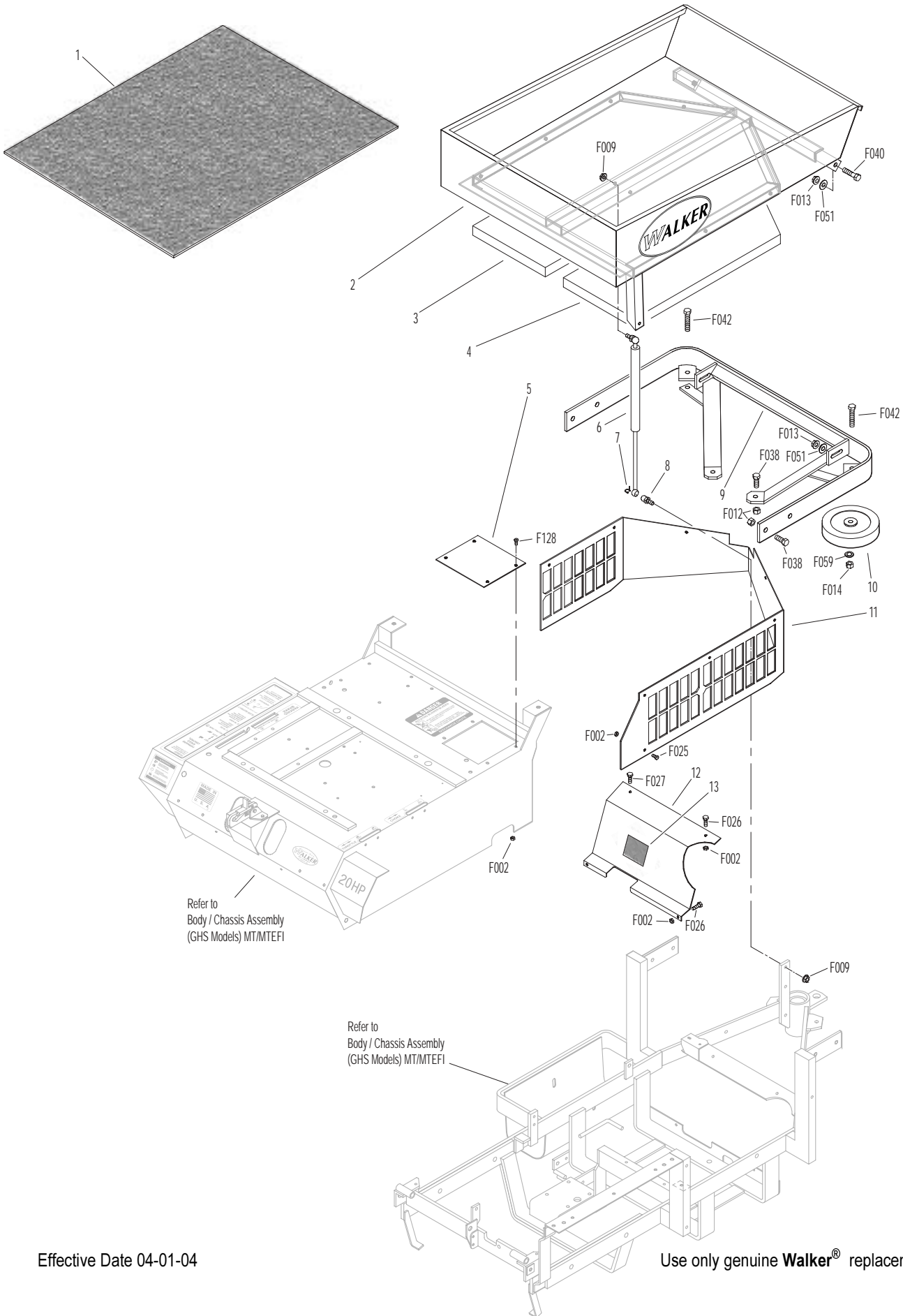

Refer to
Body / Chassis Assembly
(GHS Models) MT/MTEFI

Refer to
Body / Chassis Assembly
(GHS Models) MT/MTEFI

BODY ASSEMBLY (SD MODELS) MTL

ITEM NO.	PART NO.	DESCRIPTION	NO. REQ'D	ITEM NO.	PART NO.	DESCRIPTION	NO. REQ'D
Utility Bed Assembly				Fasteners			
1	8650-10	Bed Liner (21.5 x 27.5)	1	F002		10-24 Keps Nut	14
2	8650-3	Utility Bed	1	F009		5/16-18 Whiz Locknut	2
3	7190-2	Insulation Foam Pad, RH	1	F012		3/8-16 Keps Nut	6
4	7190-1	Insulation Foam Pad, LH	1	F013		3/8-16 Whiz Locknut	4
Rear Bumper Assembly (SD Models)				F014		3/8-16 ESNA Nut	2
5	7153-3	Cover Plate	1	F025		10-24 x 3/8 PPHMS	6
6	7145	Gas Spring Assembly (Includes Items # 7 & 8)	1	F026		10-24 x 1/2 PPHMS	3
7	7147	Spring Clip	2	F027		10-24 x 5/8 PPHMS	1
8	7146	13mm Ball Stud	2	F038		3/8-16 x 1 Hex Bolt	6
9	7521-5	Rear Bumper	1	F040		3/8-16 x 1-1/2 Hex Bolt	2
10	5162	Roller Wheel (5")	2	F042		3/8-16 x 2-1/4 Hex Bolt	2
11	8105-15	Rear Body Panel	1	F051		3/8 SAE Washer	4
12	8389-3	Splash Guard	1	F059		3/8 Wave Spring Washer	2
				F128		10-24 x 3/8 PTHMS	4

NOTE: Refer to **BODY / CHASSIS ASSEMBLY (GHS MODELS) MTL**, Page 6 for all common parts used on both models.

BODY ASSEMBLY (SD MODELS) MTL

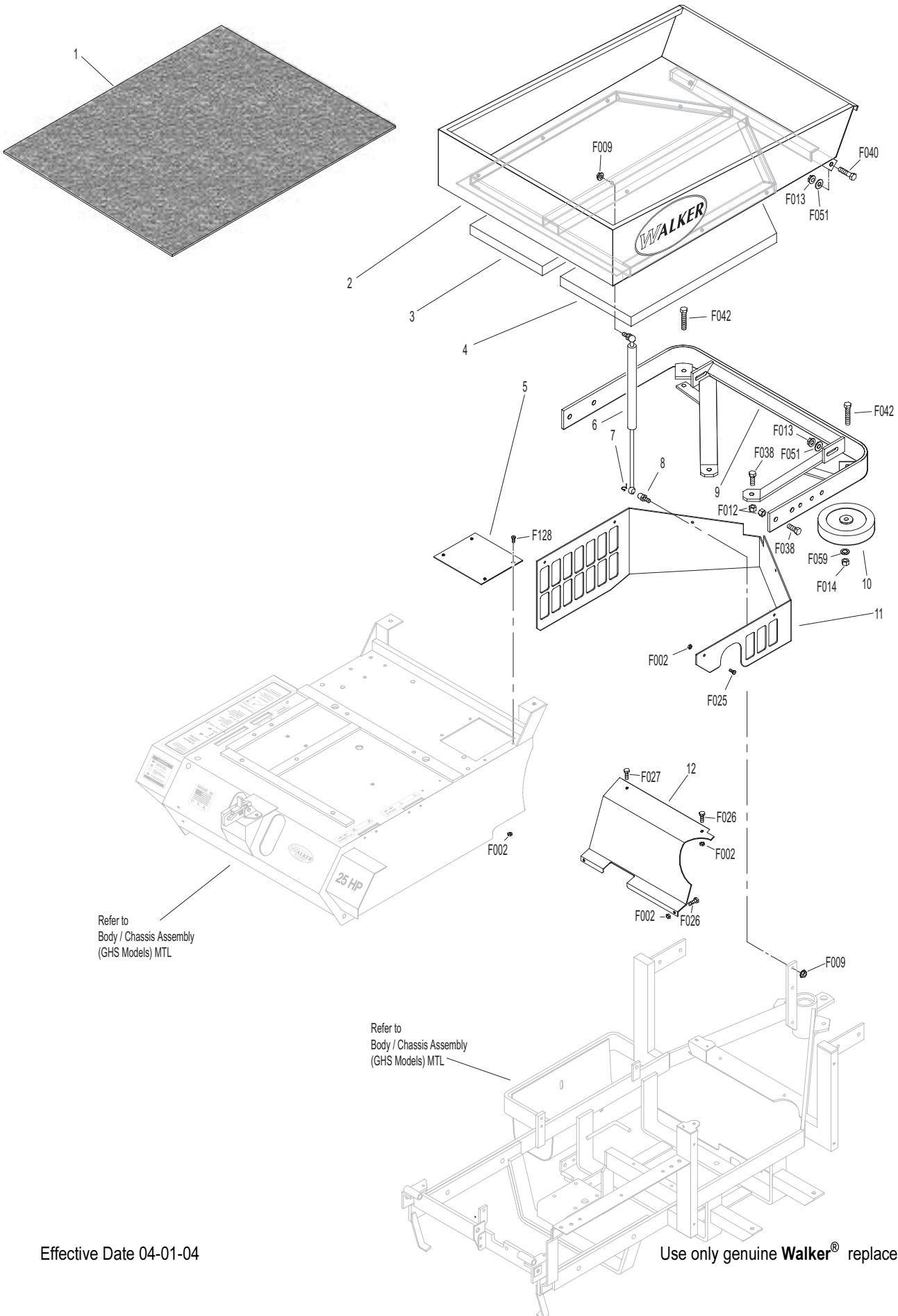

Effective Date 04-01-04

Use only genuine Walker® replacement parts.

MAIN COMPONENT POWER TRANSMISSION (GHS MODELS)

ITEM NO.	PART NO.	DESCRIPTION	NO. REQ'D	ITEM NO.	PART NO.	DESCRIPTION	NO. REQ'D
Clutch Lever Assembly				Jackshaft Assembly			
1	8358	Clutch Lever (Includes Items # 2 & 3)	1	38	7245-1	Idler Pulley (3/8 Groove)	1
2	5830	Grease Fitting	7	39	6325-2	Spacer Bushing (5/16)	2
3	7860	Handle Grip	1	40	8349-2	Idler Arm	1
4	7303-10	Clutch Actuator Bolt (3/8)	1	41	7201-4	Inner Race (1-1/2)	2
5	7380-5	Knuckle Joint (3/8 ID)	1	42	5221	Extension Spring (3/4 x 4)	2
6	7226-10	Compression Spring (3/4 x 2-1/2)	1	43	8539	Starter Relay Mount	1
7	8130-5	Push Rod, Clutch Actuator (Threaded Tube)	1	44	5268	Bearing W/Collar (3/4)	2
8	8130-10	Clutch Actuator Rod Assembly (Includes Items # 2, 4-7, F054, F336 & F353)	1	45	7241-2	Transmission Drive Pulley (3-1/4/MV) (Includes Items # F067 & F171)	1
9	7201-3	DU Bearing	6	46	7833	Cable Clamp (7/8 x 1/4)	1
10	7201-5	Inner Race (2-1/4)	1	47	8349	Transmission Belt Tightener Arm	1
11	8368	PTO Belt Tightener	1	48	8393	Jackshaft Support	1
12	5841	Retainer Washer (3/8 x 1-1/4)	4	49	8273	Jackshaft (3/4 x 7-1/2)	1
13	8243	Clutch Idler Pulley Assembly (Includes Items # 14, 15 & F070)	1	50	7240-3	Jackshaft Drive Pulley (4.15/3V) (Includes Items # F067 & F171)	1
	8243-1	Clutch Idler Pulley	1	Fasteners			
14	5265	Bearing (3/4)	1	F003	1/4-28 Hex Nut		2
15	8243-3	Hub, Idler Pulley	1	F004	1/4-20 Keps Nut		3
16	8375	PTO Belt Tightener Stop	1	F005	1/4-20 ESNA Nut		1
17	7377	Plastic Washer (7/16 x 1 x .025)	2	F009	5/16-18 Whiz Locknut		3
18	7378	Pivot Bearing (7/16 x 9/16)	1	F012	3/8-16 Keps Nut		8
19	5281-5	Clevis Pin (1/4 x 0.80)	2	F029	1/4-20 x 1/2 Hex Bolt		1
20	5280	Clevis (1/4)	2	F035	5/16-18 x 1-1/4 Hex Bolt		2
21	8305	Brake Actuator Rod	1	F040	3/8-16 x 1-1/2 Hex Bolt		1
22	8370	Bearing, Brake Actuator	1	F041	3/8-16 x 1-3/4 Hex Bolt		2
23	8250	Brake Spring (1/2 x 2-1/2)	1	F042	3/8-16 x 2-1/4 Hex Bolt		3
24	8369	Brake Actuator (Includes Items # 2 & 22)	1	F043	3/8-16 x 3 Hex Bolt		1
				F047	3/8-16 x 4-1/2 Hex Bolt		1
				F054	AN960616 Washer		3
PTO Drive Shaft Assembly					F061	1/4 Internal Star Lock Washer	1
25	7050-1	Dipstick, Gearbox	1	F067	3/16 x 3/16 x 1 Key		2
26	8371-1	Mount Bracket, Brake Band	1	F069	3/32 x 1/2 Cotter Pin		2
27	8377	Brake Band Guide	1	F070	1-3/4 Internal Snap Ring		1
28	8050-11	PTO Gearbox / Flange Pulley	1	F116	1/4-20 x 1-1/4 Hex Bolt		1
29	5245	Idler Pulley (3")	2	F121	5/16-18 x 3/8 x 1 SHL Bolt		1
30	7248	Ground Drive Belt, Micro-V	1	F131	5/16-18 x 1/2 Hex Bolt		2
31	7275-16	Universal Joint Tube Assembly/Spline	1	F132	1/4-20 x 2-3/4 Hex Bolt		1
32	7523-2	Clevis Pin (1/4 x 5/8)	1	F168	5/16 Split Lock Washer		14
33	8304	Brake Band (14-1/2)	1	F171	5/16-18 x 3/8 Set Screw		4
34	6250	Drive Belt (3VX375)	1	F178	1/4 x 1 Fender Washer		1
35	7236-1	PTO Drive Pulley (4-1/2/3V) (Includes Items # F168 & F226)	1	F182	5/8 x 1/4 x 1/8 Washer		2
36	8237-2	Engine Pulley, Bolt On (4/3.8/3V) (Includes Items # F168 & F226)	1	F186	5/64 x 1/2 Cotter Pin		1
37	8230	Engine PTO Belt	1	F226	5/16-18 x 7/8 Hex Bolt		14
				F241	.375 x .875 x .10 Washer		1
				F261	AN960616L Washer		1
				F325	1/4-20 x 3 Hex Bolt		1
				F336	3/8-16 Jam Nut		1
				F353	3/8-16 ESNA LP Nut		1

Use only genuine **Walker**[®] replacement parts.

Effective Date 04-01-04

MAIN COMPONENT POWER TRANSMISSION (GHS MODELS)

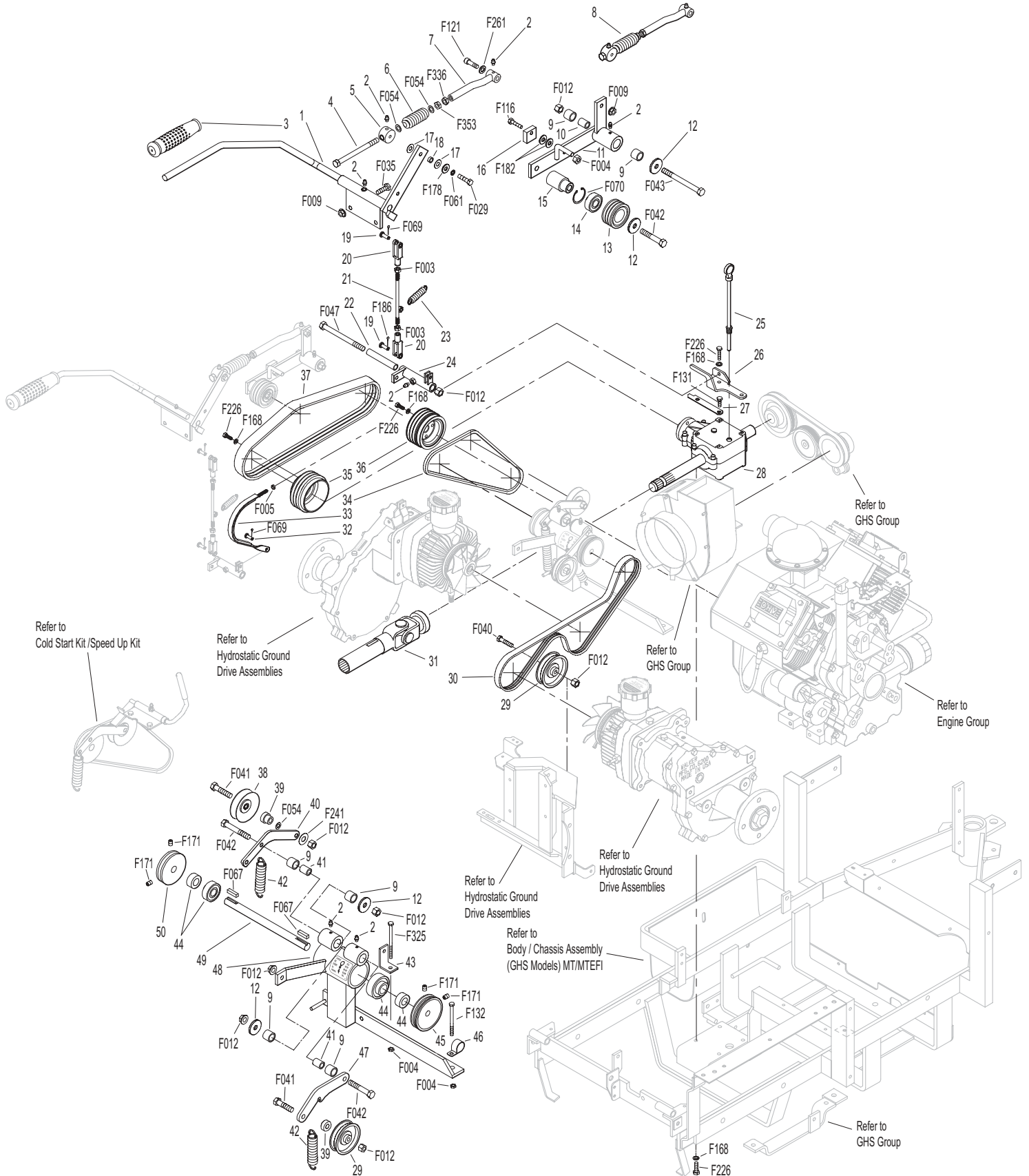

MAIN COMPONENT POWER TRANSMISSION (SD MODELS)

ITEM NO.	PART NO.	DESCRIPTION	NO. REQ'D	ITEM NO.	PART NO.	DESCRIPTION	NO. REQ'D
Clutch Lever Assembly				Jackshaft Assembly			
1	8358	Clutch Lever (Includes Items # 2 & 3)	1	38	7245-1	Idler Pulley (3/8 Groove)	1
2	5830	Grease Fitting	7	39	6325-2	Spacer Bushing (5/16)	2
3	7860	Handle Grip	1	40	8349-2	Idler Arm	1
4	7303-10	Clutch Actuator Bolt (3/8)	1	41	7201-4	Inner Race (1-1/2)	2
5	7380-5	Knuckle Joint (3/8 ID)	1	42	5221	Extension Spring (3/4 x 4)	2
6	7226-10	Compression Spring (3/4 x 2-1/2)	1	43	8539	Starter Relay Mount	1
7	8130-5	Push Rod, Clutch Actuator (Threaded Tube)	1	44	5268	Bearing W/Collar (3/4)	2
8	8130-10	Clutch Actuator Rod Assembly (Includes Items # 2, 4-7, F054, F336 & F353)	1	45	7241-2	Transmission Drive Pulley (3-1/4/MV) (Includes Items # F067 & F171)	1
9	7201-3	DU Bearing	6	46	8349	Transmission Belt Tightener Arm	1
10	7201-5	Inner Race (2-1/4)	1	47	7833	Cable Clamp (7/8 x 1/4)	1
11	8368	PTO Belt Tightener	1	48	8393	Jackshaft Support	1
12	5841	Retainer Washer (3/8 x 1-1/4)	4	49	8273	Jackshaft (3/4 x 7-1/2)	1
13	8243	Clutch Idler Pulley Assembly (Includes Items # 14, 15 & F070)	1	50	7240-3	Jackshaft Drive Pulley (Includes Items # F067 & F171)	1
	8243-1	Clutch Idler Pulley	1	Fasteners			
14	5265	Bearing (3/4)	1	F003	1/4-28 Hex Nut		2
15	8243-3	Hub, Idler Pulley	1	F004	1/4-20 Keps Nut		3
16	8375	PTO Belt Tightener Stop	1	F005	1/4-20 ESNA Nut		1
17	7377	Plastic Washer (1 x .438 x .025)	2	F009	5/16-18 Whiz Locknut		3
18	7378	Pivot Bearing (7/16 x 9/16)	1	F012	3/8-16 Keps Nut		8
19	5281-5	Clevis Pin (1/4 x 0.80)	2	F029	1/4-20 x 1/2 Hex Bolt		1
20	5280	Clevis (1/4)	2	F035	5/16-18 x 1-1/4 Hex Bolt		2
21	8305	Brake Actuator Rod	1	F040	3/8-16 x 1-1/2 Hex Bolt		1
22	8370	Bearing, Brake Actuator	1	F041	3/8-16 x 1-3/4 Hex Bolt		2
23	8250	Brake Spring (1/2 x 2-1/2)	1	F042	3/8-16 x 2-1/4 Hex Bolt		3
24	8369	Brake Actuator (Includes Items # 2 & 22)	1	F043	3/8-16 x 3 Hex Bolt		1
				F047	3/8-16 x 4-1/2 Hex Bolt		1
PTO Drive Shaft Assembly					F054	AN960616 Washer	3
25	7050-1	Dipstick, Gearbox	1	F061	1/4 Internal Star Lock Washer		1
26	8371-1	Mount Bracket, Brake Band	1	F067	3/16 x 3/16 x 1 Key		2
27	8377	Brake Band Guide	1	F069	3/32 x 1/2 Cotter Pin		2
28	8050-11	PTO Gearbox / Flange Pulley	1	F070	1-3/4 Internal Snap Ring		1
29	5245	Idler Pulley (3")	2	F116	1/4-20 x 1-1/4 Hex Bolt		1
30	7248	Ground Drive Belt, Micro-V	1	F121	5/16-18 x 3/8 x 1 SHL Bolt		1
31	7275-16	Universal Joint Tube Assembly/Spine	1	F131	5/16-18 x 1/2 Hex Bolt		2
32	7523-2	Clevis Pin (1/4 x 5/8)	1	F132	1/4-20 x 2-3/4 Hex Bolt		1
33	8304	Brake Band (14-1/2)	1	F168	5/16 Split Lock Washer		14
34	6250	Drive Belt (3VX375)	1	F171	5/16-18 x 3/8 Set Screw		4
35	7236-1	PTO Drive Pulley (4-1/2/3V) (Includes Items # F168 & F226)	1	F178	1/4 x 1 Fender Washer		1
36	8237-2	Engine Pulley, Bolt On (4/3.8/3V) (Includes Items # F168 & F226)	1	F182	5/8 x 1/4 x 1/8 Washer		2
37	8230	Engine PTO Belt	1	F186	5/64 x 1/2 Cotter Pin		1
				F226	5/16-18 x 7/8 Hex Bolt		14
				F241	.375 x .875 x .10 Washer		1
				F261	AN960616L Washer		1
				F325	1/4-20 x 3 Hex Bolt		1
				F336	3/8-16 Jam Nut		1
				F353	3/8-16 ESNA LP Nut		1

Use only genuine **Walker**[®] replacement parts.

Effective Date 04-01-04

MAIN COMPONENT POWER TRANSMISSION (SD MODELS)

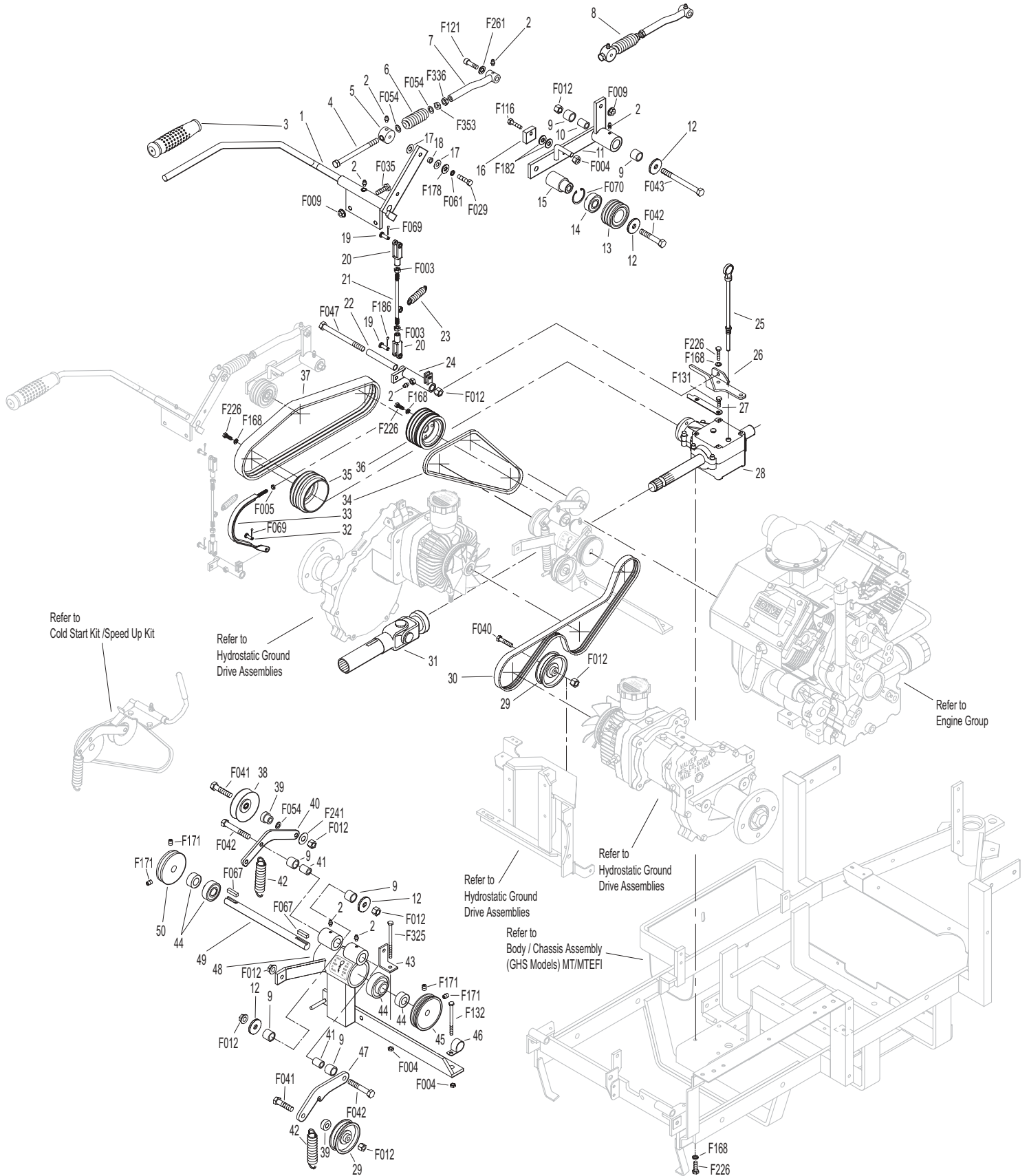

Effective Date 04-01-04

Use only genuine Walker® replacement parts.

ENGINE GROUP (MT)

ITEM NO.	PART NO.	DESCRIPTION	NO. REQ'D	ITEM NO.	PART NO.	DESCRIPTION	NO. REQ'D	
Precleaner Assembly				Exhaust Assembly				
1	7026-2	Remote Precleaner (Includes Item # 5)	1	38	8530-8	Muffler Grass Shield (Includes Items # F002 & F025)	1	
2	7440	Shock Mount (1.0 OD x .75)	3	39	NS	Screw (Kohler M-645016-S)	2	
3	7028-20	Rear Precleaner Mount	1	40	NS	Gasket (Kohler)	2	
4	7027	Elbow, Precleaner	1	41	NS	Nut (Kohler)	4	
5	7840	Hose Clamp (1-5/16 to 2-1/4)	4	42	8013-9	Muffler	1	
6	5088-12	Air Cleaner Assembly (Includes Items # 8-12 & 14)	*	43	8013-13	Muffler Heat Shield	1	
7	5088-1	Air Cleaner Band	1	44	8013-18	Muffler Brace	1	
8	5090-3	Safety Filter	1	45	8021	Engine Brace	1	
9	5090-1	Air Cleaner Cartridge	1	46	8013-29	Muffler Heat Shield Endcap	1	
10	5088-5	Air Cleaner Draw Latch	1	47	8013-61	Muffler Heat Deflector W/Knurled Inserts	1	
11	5088-11	Air Cleaner Cap (Includes Item # 10)	1	Fasteners				
12	5090-2	Vacuator Valve	1		F002	10-24 Keps Nut	2	
13	8026-10	Air Hose, Cleaner	1		F004	1/4-20 Keps Nut	4	
14	5091-11	Air Flow Indicator & Nipple	1		F009	5/16-18 Whiz Locknut	13	
15	7031	Tube Support Arm	1		F012	3/8-16 Keps Nut	1	
16	7028-3	Precleaner Tube, SD	1		F025	10-24 x 3/8 PPHMS	2	
17	7028-2	Precleaner Tube, GHS	1		F026	10-24 x 1/2 PPHMS	3	
18	6029	Hose Clamp (2-1/2)	1		F029	1/4-20 x 1/2 Hex Bolt	4	
Engine Assembly						F031	1/4-20 x 5/8 Hex Bolt	1
19	NS	20-hp Engine	1		F035	5/16-18 x 1-1/4 Hex Bolt	2	
20	NS	Fuel Pump (Kohler)	1		F038	3/8-16 x 1 Hex Bolt	2	
21	5879-3	Hose Clamp (1/2)	4		F050	1/4 SAE Washer	1	
22	NS	Fuel Line, Engine (Kohler)	*		F052	5/16 External Star Lock Washer	2	
23	5020	Fuel Filter	*		F053	7/16 Int. Star Lock Washer	2	
24	NS	Oil Filter (Kohler 1205001)	1		F061	1/4 Internal Star Lock Washer	4	
25	8010-6	Valve Cover Sleeve	2		F063	3/8 Internal Star Lock Washer	2	
26	5845	Bumper, Rubber (1.50 OD x 1.25)	1		F079	A/A66D Aluminum Pop Rivet	2	
27	8010-2	Engine Bumper Mount	1		F090	1/4-20 x 2-1/2 Hex Bolt	2	
28	5832	Cable Clamp (1/2)	3		F091	5/16-18 x 5/8 Hex Bolt	2	
Fuel Tank Assembly						F106	3/8-16 x 5/8 Hex Bolt	2
29	8015-3	Fuel Line, Tank (1/4 x 24-1/2)	1		F120	AN960416 Washer	2	
30	5083-1	Bushing, Rubber	*		F129	10-24 x 1/2 PTHMS	1	
31	5086	Fuel Line (In Tank P/U)	1		F140	7/16-14 x 1 Hex Bolt	2	
32	8023	Fuel Tank Support	1		F175	1/2 Split Lock Washer	4	
33	5020-1	Fuel Filter, In Tank	1		F256	7/16 SAE Washer	2	
34	8046-9	Fuel Tank, 5 Gallon, Gas (Includes Items # 35 & 36)	1		F273	M6 x 1.0 Nut	4	
35	5082-2	Fuel Cap Seal	*		F274	M6 x 1.0 45 Stud	2	
36	5082	Fuel Tank Cap (Includes Item # 35)	*		F285	1/2-13 x 1-1/2 Hex Bolt	4	
37	5083-2	Tank Tube Elbow	1		F324	M8 x 1.25 x 12 Hex Bolt	2	

* Service Part Only

NOTE: Item 16 is used only on SD Models. Item 17 is used only on GHS Models. Both items use existing fasteners at clutch lever.

NOTE: Refer to Kohler Engine Decal (NS) for Engine Identification Numbers.

ENGINE GROUP (MT)

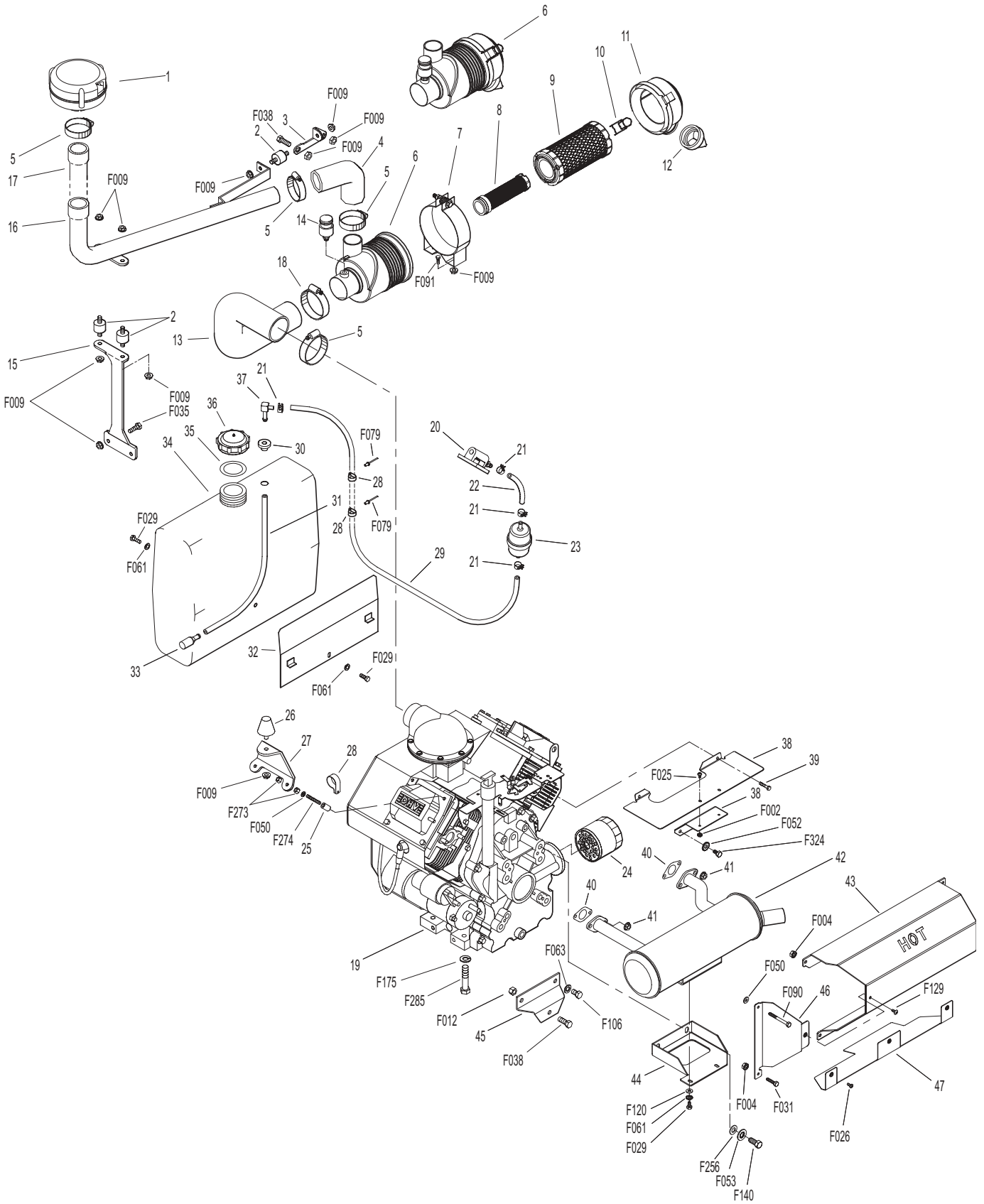

Effective Date 04-01-04

Use only genuine Walker® replacement parts.

ENGINE GROUP (MTL)

ITEM NO.	PART NO.	DESCRIPTION	NO. REQ'D	ITEM NO.	PART NO.	DESCRIPTION	NO. REQ'D
Fuel Tank Assembly				Engine Assembly			
1	5083-2	Tank Tube Elbow	1	22	NS	Oil Filter (Kohler 1205001)	1
2	5879-3	Hose Clamp (1/2)	4	23	NS	Regulator (Kohler)	1
3	8015-3	Hose (1/4 x 24-1/2)	1	24	8012-3	Regulator Mount	1
4	NS	Fuel Pump (Kohler)	1	25	NS	25-hp Engine	1
5	NS	Fuel Line (Kohler)	1	26	7306-12	Temperature Sender Adapter	1
6	5020	Fuel Filter	*	27	7306-15	Water Temperature Sender	1
7	5832	Cable Clamp (1/2) (Uses Existing Fasteners at Engine)	2	Fasteners			
8	5083-1	Bushing, Rubber	*		F004	1/4-20 Keps Nut	2
9	5086	Fuel Line (In Tank P/U)	1		F009	5/16-18 Whiz Locknut	2
10	5020-1	Fuel Filter, In Tank	1		F012	3/8-16 Keps Nut	5
11	8046-9	Fuel Tank, 5 Gallon, Gas (Includes Items # 12 & 13)	1		F029	1/4-20 x 1/2 Hex Bolt	1
12	5082-2	Fuel Cap Seal	*		F031	1/4-20 x 5/8 Hex Bolt	1
13	5082	Fuel Tank Cap (Includes Item # 12)	*		F038	3/8-16 x 1 Hex Bolt	1
Exhaust Assembly					F041	3/8-16 x 1-3/4 Hex Bolt	4
14	8013-81	Muffler Heat Shield	1		F051	3/8 SAE Washer	4
15	8013-16	Mounting Spring, Muffler	6		F061	1/4 Internal Star Lock Washer	1
16	8013-15	Hanger Bracket, Muffler	1		F063	3/8 Internal Star Lock Washer	3
17	8013-12	Muffler	1		F079	A/A66D Aluminum Pop Rivet	2
18	8013-17	Exhaust Pipe, Muffler	1		F091	5/16-18 x 5/8 Hex Bolt	2
19	7958-2	Resistor Mount Plate	1		F106	3/8-16 x 5/8 Hex Bolt	2
20	NS	Gasket (Kohler)	2		F243	M6 Split Lock Washer	4
21	NS	Nut (Kohler)	4		F273	M6 x 1.0 Nut	2
					F328	M6 x 1.0 x 16 Hex Bolt	4
				*	Service Part Only		

NOTE: Refer to Kohler Engine Decal (NS) for Engine Identification Numbers.

ENGINE GROUP (MTL)

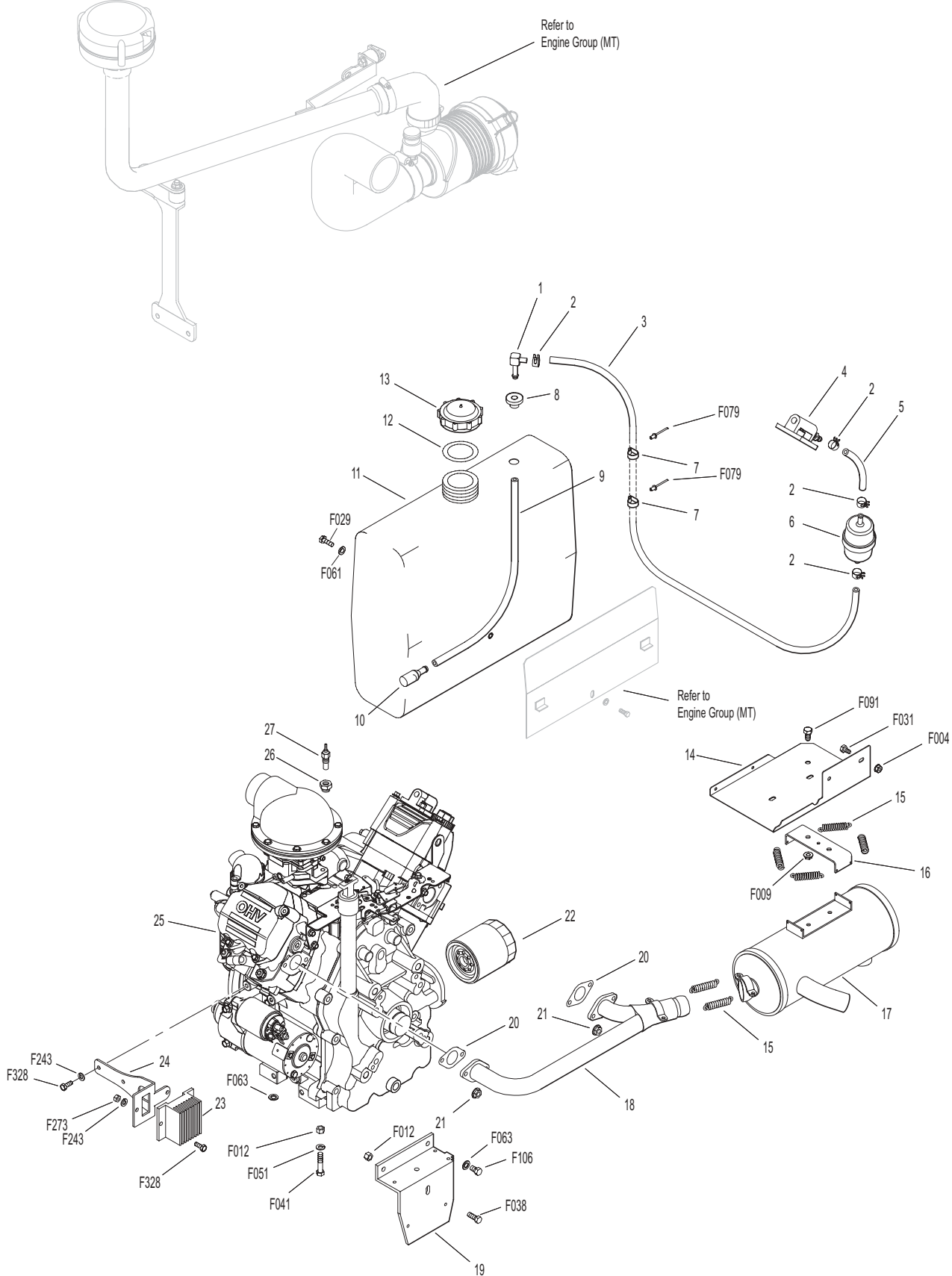

ENGINE GROUP (MTEFI)

ITEM NO.	PART NO.	DESCRIPTION	NO. REQ'D	ITEM NO.	PART NO.	DESCRIPTION	NO. REQ'D
Fuel Tank Assembly				Exhaust Assembly			
1	5083-2	Tank Tube Elbow	1	29	8530-9	Grass Shield, Muffler (EFI) (Includes Items # F002 & F025)	1
2	5879-5	Stepless Ear Clamp (5/8)	7	30	NS	Screw (Kohler M645016-S)	1
3	8026-3	Fuel Line (5/16 x 32) Tank to Pump (Includes Item # 2)	1	31	NS	Sensor, Oxygen (Kohler)	1
4	7833	Cable Clamp (7/8 x 1/4)	4	32	NS	Gasket (Kohler)	2
5	8026-5	Fuel Line (5/16 x 21) Regulator to Filter (Includes Item # 2)	1	33	NS	Nut (Kohler M-0841080)	4
6	8026-14	Clamp, Loop Style	1	34	8013-11	Muffler (EFI)	1
7	5879-3	Hose Clamp (1/2)	2	35	8013-13	Muffler Heat Shield	1
8	NS	Fuel Regulator (Kohler)	1	36	8013-18	Muffler Brace	1
9	NS	Fuel Filter (Kohler)	1	37	8021	Engine Brace	1
10	8026-4	Fuel Line (5/16 x 8) Pump to Regulator (Includes Item # 2)	1	38	8013-29	Muffler Heat Shield Endcap	1
11	8026-6	Fuel Line (5/16 x 13") Filter to Engine (Includes Item # 2)	1	39	8013-61	Muffler Heat Deflector W/Knurled Inserts	1
12	NS	Fuel Pump (Kohler)	1	Fasteners			
13	8123	Insulating Sleeve (3/8 x 6)	1	F002	10-24 Keps Nut	5	
14	NS	Clamp (Kohler)	2	F004	1/4-20 Keps Nut	6	
15	7014-3	Fuel Pump Mount Plate	1	F012	3/8-16 Keps Nut	1	
16	8026-8	Vent Tube	1	F025	10-24 x 3/8 PPHMS	4	
17	7014-2	Regulator/Filter Mount	1	F026	10-24 x 1/2 PPHMS	3	
18	5832	Cable Clamp (1/2) (Uses Existing Fasteners at Engine)	3	F027	10-24 x 5/8 PPHMS	3	
19	5083-1	Bushing, Rubber	*	F029	1/4-20 x 1/2 Hex Bolt	3	
20	7046-1	Fuel Return Tube	1	F031	1/4-20 x 5/8 Hex Bolt	4	
21	8026-7	Hose (1/4 x 16)	1	F038	3/8-16 x 1 Hex Bolt	1	
22	5086	Fuel Line (In Tank P/U)	1	F050	1/4 SAE Washer	1	
23	5020-1	Fuel Filter, In Tank	1	F052	5/16 External Star Lock Washer	2	
24	5082	Fuel Tank Cap (Includes Item # 25)	*	F053	7/16 Int. Star Lock Washer	2	
25	5082-2	Fuel Cap Seal	*	F061	1/4 Internal Star Lock Washer	4	
26	8046-7	Fuel Tank, 5 Gallon, Gas (Includes Items # 19, 24 & 25)	1	F063	3/8 Internal Star Lock Washer	2	
Engine Assembly				F079	A/A66D Aluminum Pop Rivet	2	
27	NS	Oil Filter (Kohler 1205001)	1	F090	1/4-20 x 2-1/2 Hex Bolt	1	
28	NS	26-hp EFI Engine (78528)	1	F106	3/8-16 x 5/8 Hex Bolt	2	
				F120	AN960416 Washer	2	
				F129	10-24 x 1/2 PTHMS	1	
				F140	7/16-14 x 1 Hex Bolt	2	
				F175	1/2 Split Lock Washer	4	
				F256	7/16 SAE Washer	2	
				F285	1/2-13 x 1-1/2 Hex Bolt	4	
				F324	M8 x 1.25 x 12 Hex Bolt	2	

* Service Part Only

NOTE: Refer to Kohler Engine Decal (NS) for Engine Identification Numbers.

ENGINE GROUP (MTEFI)

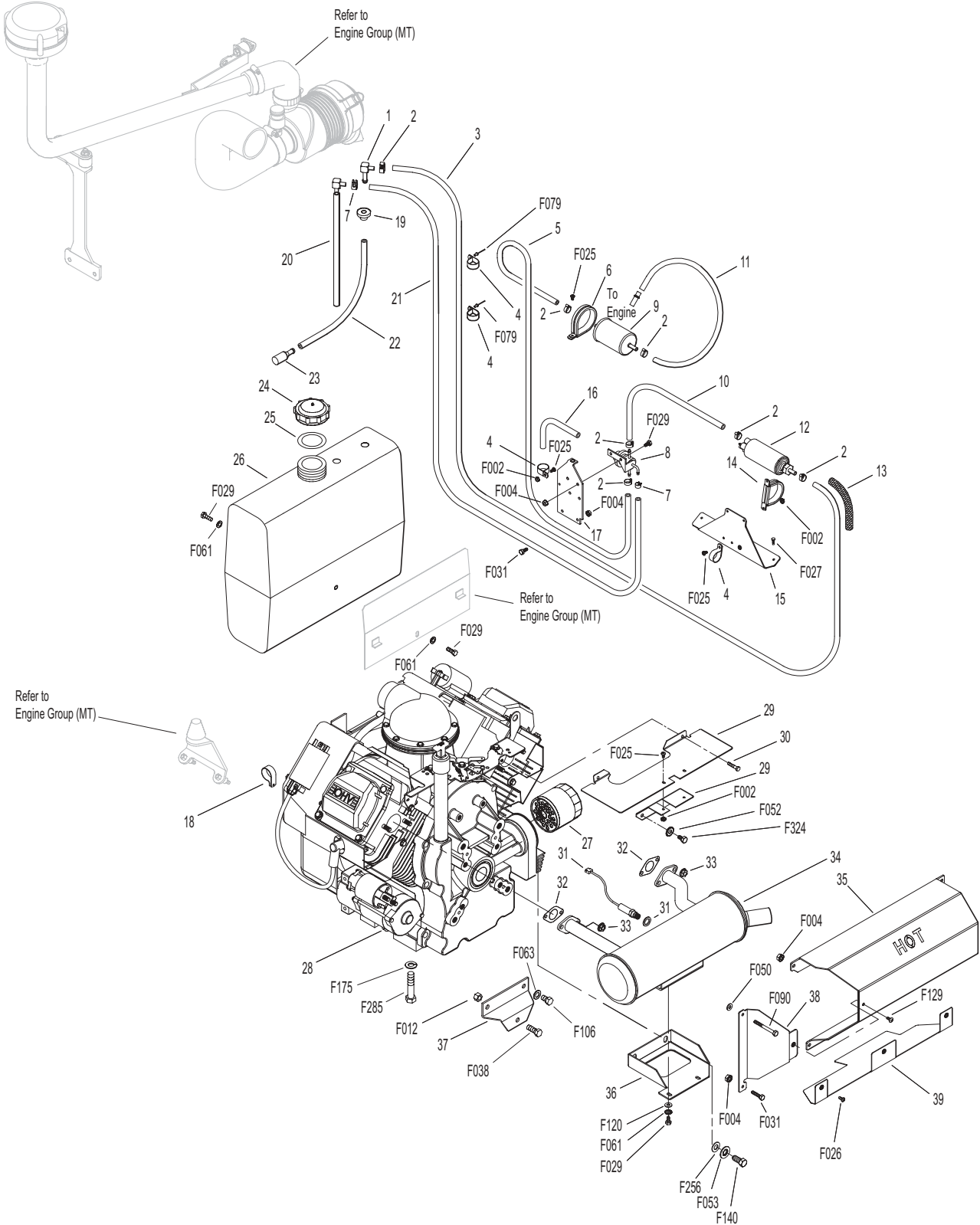

RADIATOR GROUP (MTL)

ITEM NO.	PART NO.	DESCRIPTION	NO. REQ'D	ITEM NO.	PART NO.	DESCRIPTION	NO. REQ'D
Radiator Assembly				25	7840-4	Hose Clamp (3/4 to 1-1/2)	2
1	7429-8	Radiator Fan Shield (Includes Items # 20 & 21)	1	26	8530-7	Exhaust Shield Mount, MTL	1
2	7427-21	Fan Mount Tab, LH	2	27	7017-5	Upper Radiator Hose	1
3	7429-6	Radiator Cooling Fan	1	Fasteners			
4	7432	Shock Mount (1.00 OD x .75) Radiator	2		F002	10-24 Keps Nut	2
5	7015-13	Recovery Tank Hose	1		F004	1/4-20 Keps Nut	10
6	7427-3	Coolant Recovery Tank	1		F009	5/16-18 Whiz Locknut	2
7	7427-4	Recovery Tank Mount (Includes Items # 8, F002 & F025)	1		F014	3/8-16 ESNA Nut	1
8	7047-6	Coolant Tank Shield	1		F025	10-24 x 3/8 PPHMS	1
9	7427-6	Radiator Fan Shroud	1		F026	10-24 x 1/2 PPHMS	1
10	7427-30	Radiator, MTL	1		F029	1/4-20 x 1/2 Hex Bolt	4
11	7431-1	Radiator Channel Seal (1/4 x 1/2 x 13.5)	2		F031	1/4-20 x 5/8 Hex Bolt	6
12	7435	Radiator Brace	1		F050	1/4 SAE Washer	1
13	7425	Radiator Screen	1		F053	7/16 Int. Star Lock Washer	2
14	7426	Screen Channel	2		F061	1/4 Internal Star Lock Washer	6
15	7434	Rubber Washer (3/8 x 1-1/4 x 1/4)	4		F073	1/4 x 1.5 Fender Washer	1
16	7430	Radiator Guard	1		F081	A/A45D Aluminum Pop Rivet	1
17	5841	Retainer Washer (3/8 x 1-1/4)	2		F090	1/4-20 x 2-1/2 Hex Bolt	2
18	7427-7	Debris Shield, Shroud	1		F091	5/16-18 x 5/8 Hex Bolt	2
19	7427-22	Fan Mount Tab, RH	2		F129	10-24 x 1/2 PTHMS	7
20	8620-30	Backing Plate	1		F140	7/16-14 x 1 Hex Bolt	2
21	5161-10	Rubber Flap	1		F360	1/4-20 x 3/8 Hex Bolt	1
22	7840-3	Hose Clamp (1/2 to 1-1/4)	2	NOTE: Decals for this assembly are not shown here. Refer to TRACTOR DECALS , Page 2 for Decal listing and placement information.			
23	7017-4	Lower Radiator Hose	1				
24	7833-1	Single Eyelet Clamp	1				

RADIATOR GROUP (MTL)

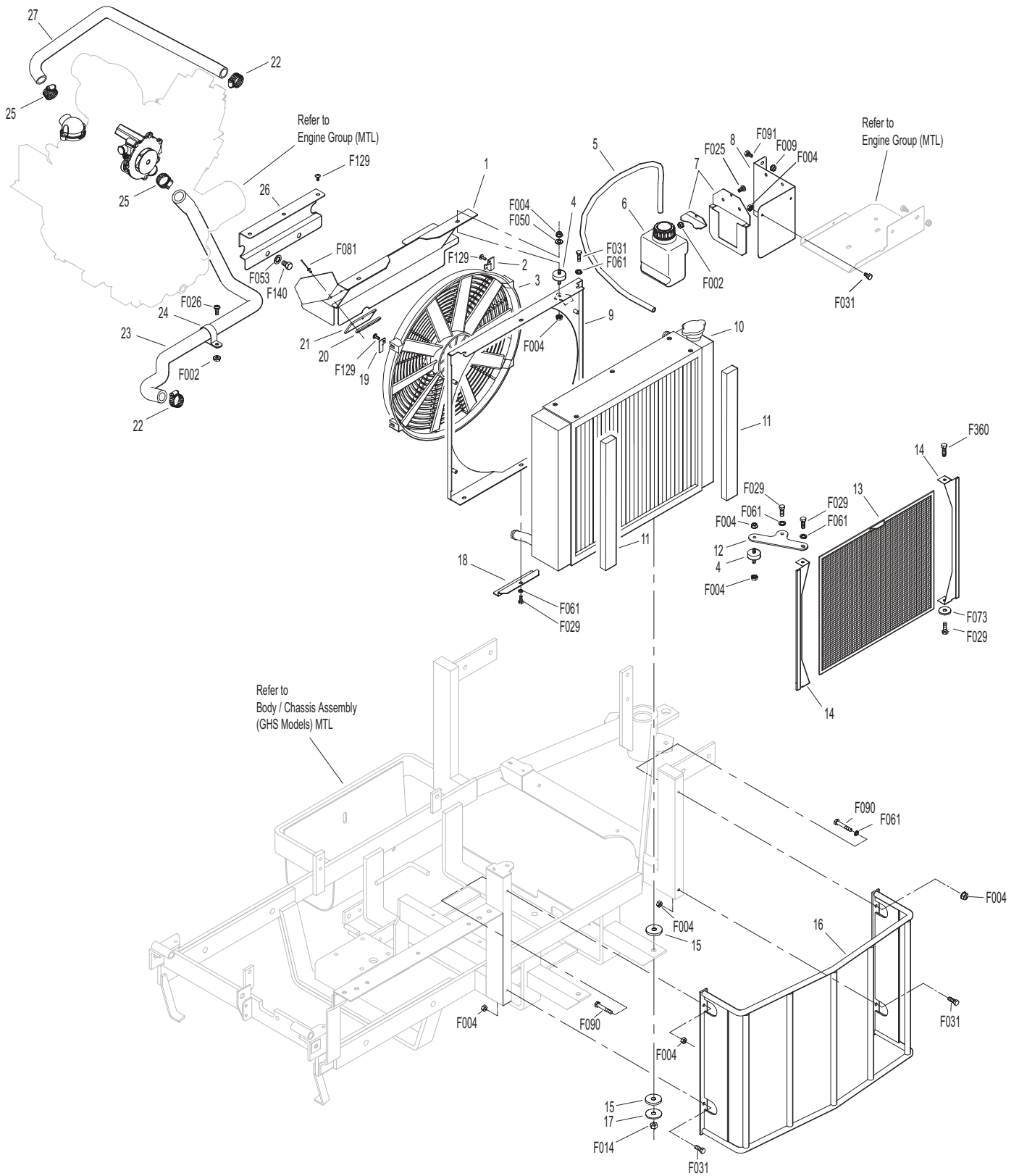

HYDROSTATIC GROUND DRIVE ASSEMBLIES

ITEM NO.	PART NO.	DESCRIPTION	NO. REQ'D	ITEM NO.	PART NO.	DESCRIPTION	NO. REQ'D
Transmission Lockout Assembly				Transmission Repair Parts			
1	5028-3	Transmission Lockout Assembly (Includes Items # 2-5, F023, F027 & F081)	*	26	5025-5	Input Shaft	*
2	5847	Plastic Tip	2	27	5025-8	Bearing, Input Shaft	*
3	5057	Lockout Cam (Includes Item # F081)	2	28	5025-7	Snap Ring	*
4	5028-5	Lockout Lever	2	29	5025-2	Seal, Input Shaft	*
5	5027-5	Lockout Mount	2	30	5022	Reservoir to Casting Gasket	*
Ground Drive Assemblies				31	5024	Reservoir Cap and Gasket	*
6	6209-1	Bridge Assembly	1	32	5023	Transmission Reservoir Kit	*
7	6243-2	Hydro Fan, CCW	1	33	5023-1	Rubber Bladder	*
8	5026	Hydrostatic Drive, CW (700-041)	1	34	5025-6	O-Ring & Plug Assembly	*
9	6206-1	Air Vent Valve	*	35	5025-3	Seal, Control Shaft	*
10	6200-9	Gear Axle Drive Assembly (Includes Item # 9 & 11)	2	Fasteners			
11	6207-12	Pipe Plug (1/4 NPTF)	4	F012	3/8-16 Keps Nut		1
12	5126	Cable Retainer (Uses existing bolt on Gear Axle Drive Assembly)	1	F023	10-24 ESNA Nut		2
13	6233-1	Pinion Gear	2	F027	10-24 x 5/8 PPHMS		2
14	6234	Spacer, Pinion Gear	2	F036	1/4-20 x 1/2 SBH Screw		2
15	6201	O-Ring Seal	2	F038	3/8-16 x 1 Hex Bolt		4
16	7244	Hydro Pulley (3-7/8) (Includes Items # F064 & F359)	2	F040	3/8-16 x 1-1/2 Hex Bolt		4
17	6243-1	Hydro Fan, CW	1	F043	3/8-16 x 3 Hex Bolt		6
18	5025	Hydrostatic Drive, CCW (700-042)	1	F053	7/16 Internal Star Lock Washer		4
Deck Support Arm Assemblies				F063	3/8 Internal Star Lock Washer		16
19	6430-10	Outboard Mount, LH	1	F064	1/8 x 1/2 Woodruff Key (#3)		4
20	6430-2	Deck Support Arm, LH (Includes Item # 24)	1	F081	A/A45D Aluminum Pop Rivet		2
21	5775-2	Hitch Pin (# 6)	2	F160	External Snap Ring (.669 Shaft)		2
22	6430-1	Deck Support Arm, RH (Includes Item # 24)	1	F178	1/4 x 1 Fender Washer		2
23	6430-9	Outboard Mount, RH	1	F194	7/16 x 1-1/4 x 1/8 Washer		2
24	5830	Grease Fitting	2	F200	7/16-20 x 3 Grade 8 Bolt		2
25	6840-1	Support Arm Bushing (2-1/16)	2	F244	7/16-20 x 3/4 Hex Bolt		2
				F262	3/8-16 x 4 Hex Bolt (Spec) All Thread		1
				F359	5/16-18 x 5/16 Set Screw (Unbrako Knurl Point)		4
				* Service Part Only			

STEERING CONTROL ASSEMBLIES

ITEM NO.	PART NO.	DESCRIPTION	NO. REQ'D	ITEM NO.	PART NO.	DESCRIPTION	NO. REQ'D
Transmission Spring Assemblies				35	5450-3	Steering Lever Assembly, RH / Adjustable (Includes Items # 16, 21, 36, F188, F198 & F345)	1
1	6199	Transmission Spring Assembly (RH) (Includes Items # 2-8, F003, F287, F320 & F352)	*		5450-5	Steering Lever Arm, RH / Adjustable	*
2	5552	Ball Joint (1/4-28)	2	36	5453-10	Steering Lever Handle, Adjustable (Includes Items # 21 & F345)	2
3	5192-1	Spring Plunger (5/32)	2	37	5862	FSC Knob	1
4	5194	Plunger Sleeve	2	38	7170	FSC Lever Assembly (Includes Item # 16)	1
5	5193	3/4 x 1 x .085 Washer	2	39	5975-3	Cable Tie (50# x 7")	1
6	6191	Spring Slide (4-3/4)	1	40	5213-1	Control Rod, RH (15")	1
7	5195	Compression Spring (1 x 5-1/8)	2	Fasteners			
8	6196	Spring Slide Cap	1		F003	1/4-28 Hex Nut	3
9	5197	J-Bolt	1		F004	1/4-20 Keps Nut	8
10	5191	Spring Slide (3-5/8)	1		F007	5/16-18 Jam Nut	1
11	5199	Transmission Spring Assembly (LH) (Includes Items # 2-5, 7, 9, 10, F003, F146, F287 & F352)	*		F008	5/16-24 Keps Nut	2
Steering Lever & FSC Assemblies					F009	5/16-18 Whiz Locknut	1
12	5214-2	Ball Joint (5/16-24) Nylon Lined	2		F010	5/16-24 ESNA Nut	2
13	5173	FSC Actuator Rod	1		F012	3/8-16 Keps Nut	2
14	5172	Bearing, Nylon (.255 ID x .379 OD x .250)	1		F024	5/16-24 Jam Nut	2
15	5142-2	FSC Actuator Cam	1		F029	1/4-20 x 1/2 Hex Bolt	2
16	5830	Grease Fitting	6		F032	1/4-20 x 3/4 Hex Bolt	4
17	6212	Transmission Control Arm, RH	1		F034	5/16-18 x 3/4 Hex Bolt	1
18	5141	FSC Friction Washer (1-1/2 x 3/8 x 1/16)	2		F050	1/4 SAE Washer	3
19	5140-15	FSC Friction Body (Includes Item # 16)	1		F051	3/8 SAE Washer	2
20	5142-7	FSC Key W/Stop	1		F064	1/8 x 1/2 Woodruff Key (#3)	2
	5140-13	FSC Control Assembly (Includes Items # 16, 18-20, F192 & F193)	*		F068	1/8 x 1 Cotter Pin	1
21	5850-2	Handle Grip, Foam (5-1/2)	2		F069	3/32 x 1/2 Cotter Pin	1
22	5212-2	Transmission Control Arm, LH	1		F093	5/16-18 x 1 Hex Bolt	1
23	5213-2	Control Rod, LH (6")	1		F134	AN960816L Washer	1
24	5223	Extension Spring (1/4 x 5-1/2)	2		F146	1/4-20 Jam Nut	1
25	5450	D-Clip	2		F182	1/4 x 5/8 x 1/8 Washer	2
26	5463	Steering Lever Actuator	2		F183	.312 x .700 x .074 Washer	2
27	5214-1	Bearing (.320 x .438 x .250)	2		F186	5/64 x 1/2 Cotter Pin	1
28	5391-3	Steering Lever Support	1		F188	1/4-20 Self-Locking Nut	4
29	5217	Pivot Pin, Steering Lever	1		F192	3/8-24 Self-Locking Nut	1
30	5451-3	Steering Lever Assembly, LH / Adjustable (Includes Items # 16, 21, 36, F188, F198 & F345)	1		F193	3/8 Belleville Spring Washer	3
	5451-5	Steering Lever Arm, LH / Adjustable	*		F198	.250 x .625 x .040 Washer, SS	2
31	5219	Extension Spring (3/4 x 6-3/4)	1		F287	1/4-28 Keps Nut	2
32	5280	Clevis (1/4)	1		F320	1/8 x 3/4 Split Spring Pin	1
33	5281-5	Clevis Pin (1/4 x 0.80)	1		F345	1/4-20 x .770 Knurled Bolt	4
34	5470-1	Speed Control Stop	1		F352	5/32 x 1 Heavy Duty Roll Pin	2
				*	Service Part Only		

Use only genuine **Walker**[®] replacement parts.

Effective Date 04-01-04

STEERING CONTROL ASSEMBLIES

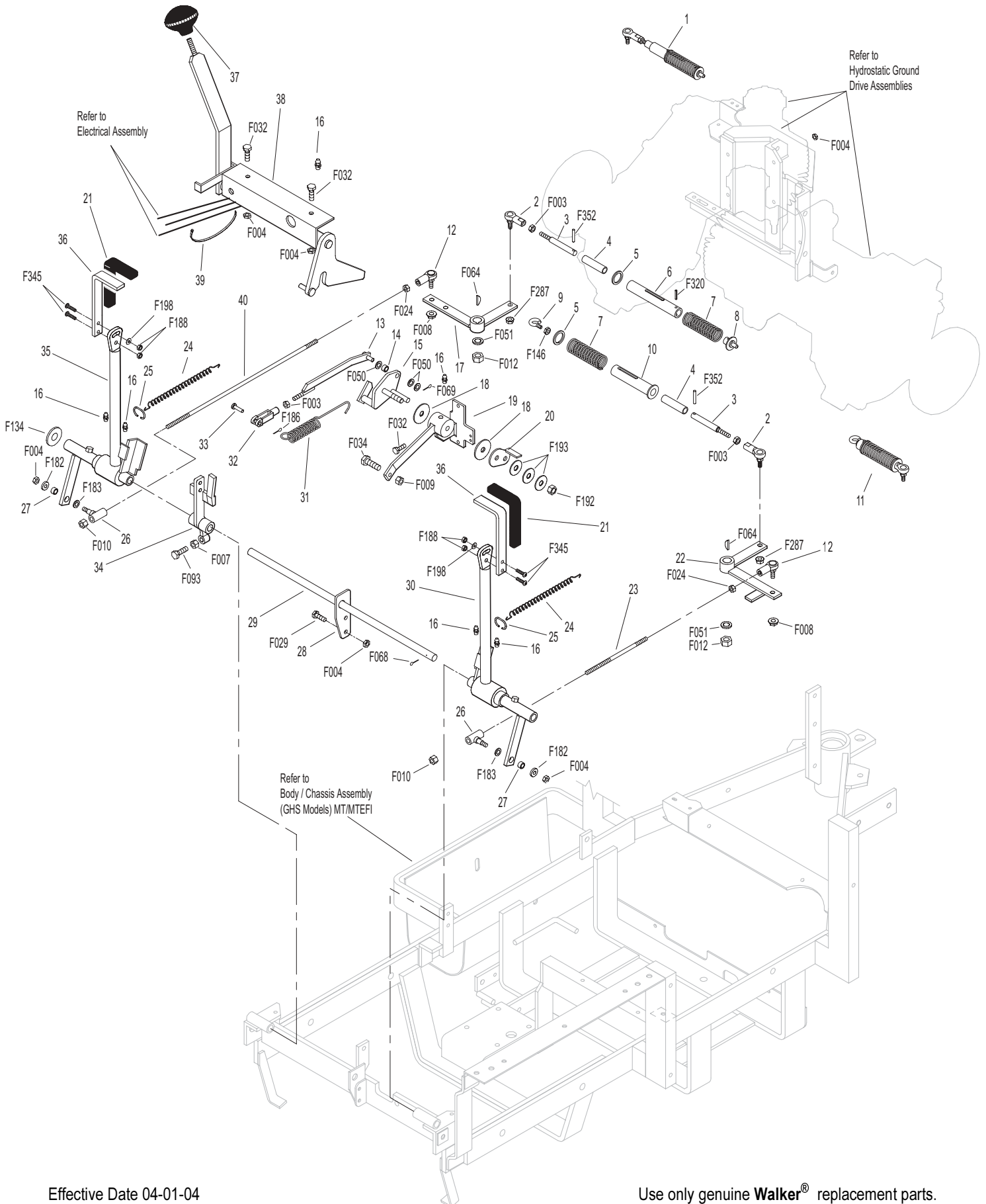

THROTTLE & CHOKE CONTROL ASSEMBLY

ITEM NO.	PART NO.	DESCRIPTION	NO. REQ'D	ITEM NO.	PART NO.	DESCRIPTION	NO. REQ'D
Throttle & Choke Control Assemblies				Fasteners			
1	8121-1	Throttle Cable	1		F004	1/4-20 Keps Nut	4
2	8122-1	Choke Cable	1		F005	1/4-20 ESNA Nut	2
3	5172	Bearing, Nylon (.255 x .379 x .250)	2		F029	1/4-20 x 1/2 Hex Bolt	2
4	5108-7	Control Lock Tab	2		F050	1/4 SAE Washer	1
5	5108-10	Friction Washer (.125)	2		F164	10-24 x 1/4 x 3/8 SHL Bolt	1
6	5108-1	Control Lever, Throttle & Choke	2		F201	1/4 Belleville Spring Washer	4
7	5108-5	Throttle Control Knob, Red	1				
8	5108-11	Friction Washer (.062)	2	*	Service Part Only		
9	5108-8	Control Bracket	2				
10	7108	Control Assembly (Includes Items # 4-6, 8, 9 & F201)	2	Δ	Model MTEFI does not use choke.		
	8121	Throttle Control and Cable Assembly (Includes Item # 7)	*				
	8122	Choke Control and Cable Assembly (Includes Item # 11)	*Δ				
11	5108-6	Choke Control Knob, Black	1				
12	8123	Insulation Sleeve (3/8 x 6)	1				
13	5975-1	Cable Tie (18# x 3-3/4")	1				

THROTTLE & CHOKE CONTROL ASSEMBLY

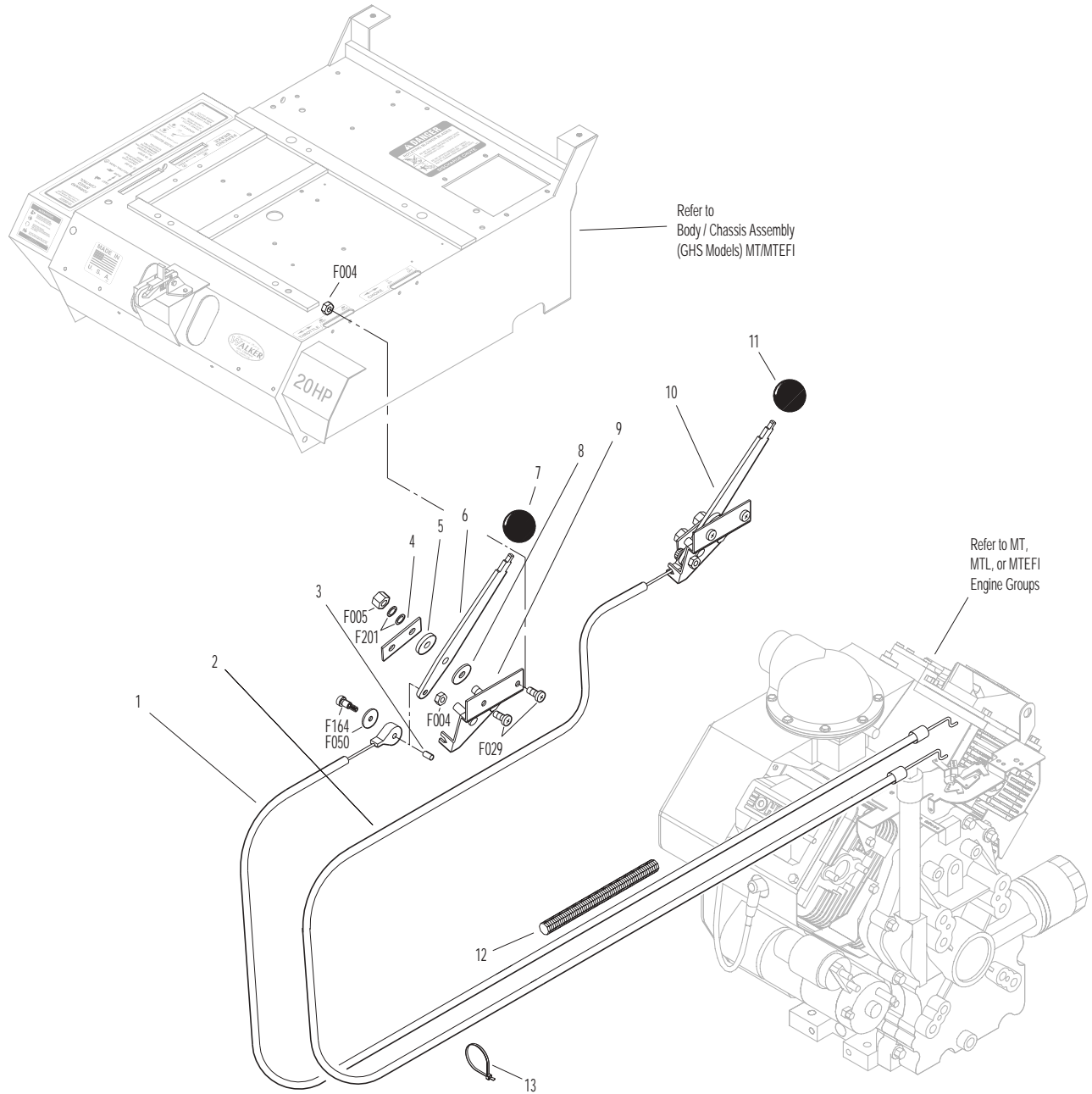

PARKING BRAKE ASSEMBLY

ITEM NO.	PART NO.	DESCRIPTION	NO. REQ'D	ITEM NO.	PART NO.	DESCRIPTION	NO. REQ'D
Parking Brake Assembly				Fasteners			
1	7406-1	Handle Grip, Red	1	F003		1/4-28 Hex Nut	1
2	7406-8	Parking Brake Lever (4-1/4)	1	F004		1/4-20 Keps Nut	6
3	7406-2	Lever Mount	1	F029		1/4-20 x 1/2 Hex Bolt	5
4	5830	Grease Fitting	1	F032		1/4-20 x 3/4 Hex Bolt	1
5	7407	Clevis Pin (3/16 x 1/2)	2	F054		AN960616 Washer	2
6	7404	Brake Actuator Arm	2	F072		1/4 "E" Retainer Ring	2
7	7405	Pin, Transmission Lock	2	F086		#10 SAE Washer	4
8	7402	Clevis	2	F109		1/8 x 5/8 Roll Pin	2
9	7408	Compression Spring (1/2 x 3/4)	2	F111		1/8 x 3/4 Cotter Pin	1
10	7415	Rubber Dust Shield (5/8 x 3/8 x 1/32)	2	F112		5/8 x 1-1/4 x .03 Washer	2
11	5567-3	O-Ring Seal (1/4 x 3/8)	4	F127		1/16 x 1/2 Cotter Pin	4
12	7403	Plunger Bushing, Gear Axle	2	F261		AN960616L Washer	5
13	7404-1	Brake Actuator Mount	2	F287		1/4-28 Keps Nut	1
14	7412	Clevis Pin (3/16 x 5/8)	2				
15	5833	Cable Clamp (1/4)	2				
16	7410	Brake Control Cable, LH (27")	1				
17	7409	Brake Control Cable, RH (21")	1				
18	7401-3	Cable Mount Bracket	1				
19	7401-1	Cable Pull Rod	1				
20	5552	Ball Joint (1/4-28)	1				

PARKING BRAKE ASSEMBLY

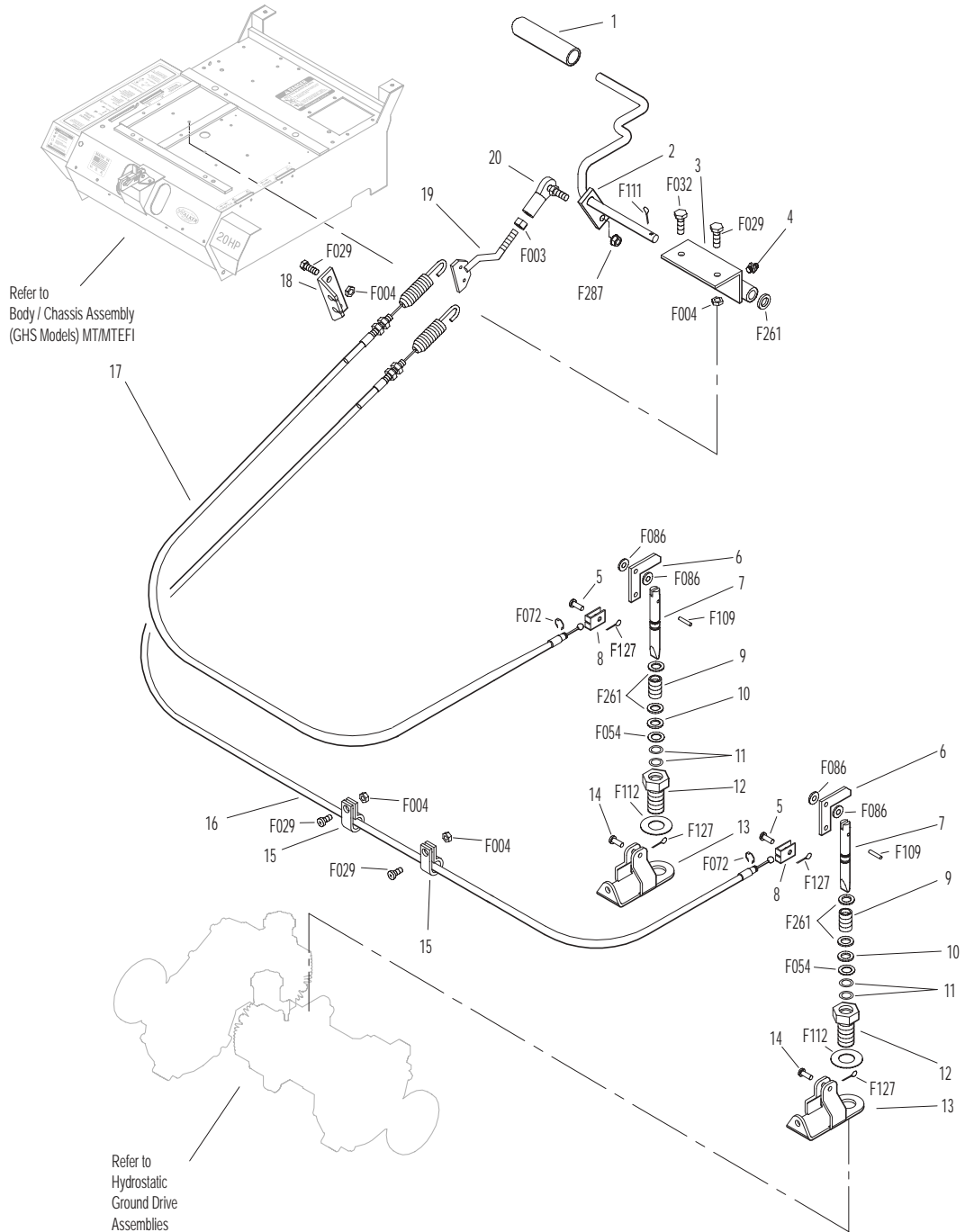

GHS GROUP

ITEM NO.	PART NO.	DESCRIPTION	NO. REQ'D
----------	----------	-------------	-----------

Delivery Chute Assembly

When Optional 9.5 Bushel Catcher Assembly is purchased, Item # 6 is replaced by P/N 8511-1 (Delivery Chute Assembly, 9.5).

1	5515-2	Elbow Delivery Spout	1
2	5592-13	Backing Plate, Grass-Pak® Switch	1
3	5592-12	Mount Plate, Grass-Pak® Switch	1
4	5578	Rear Clip, Chute Mount	1
5	5577	Side Clip, Chute Mount	2
6	7511-1	Delivery Chute W/Clips / 7.0 (Includes Items # 4, 5, 7, F079, F085 & F362)	1
	8511-1	Delivery Chute W/Clips / 9.5 (Includes Items # 4, 5, 7, F079, F085 & F362)	
7	5578-10	Front Clip, Chute Mount	1
8	7530-3	Body Chute	1

Blower Belt Tightener Assembly

9	7238-1	Blower Drive Pulley (Mirco-V) (Includes Items # F075, F114 & F231)	1
10	7234-1	Blower Belt (Micro-V)	1
11	7239-1	Blower Pulley (Mirco-V) (Includes Items # F067, F075 & F114)	1
12	7364-2	Torsion Spring	1
13	7201-3	DU Bearing	2
14	5830-3	Grease Fitting (45 Deg.)	1
15	7364-1	Blower Belt Tightener Arm	1
16	7201-4	Inner Race (1-1/2)	1
17	5841	Retainer Washer (3/8 x 1-1/4)	1
18	5245	Idler Pulley (3")	1

Blower Assembly

19	5268	Bearing W/Collar (3/4)	2
20	6543	Housing (10" Blower)	1
	6542	Blower Assembly (10") (Includes Items # 19, 21-23 & F004)	*
21	6545	Blower Wheel (10")	1
22	6525-2	Faceplate (10" Blower)	1
23	6526	Intake Tube (6-1/2 x 2-1/2)	1
24	5595-2	Intake Cover/GHS	**
25	7528	Skid Bar (10" Blower)	1
26	7833	Cable Clamp (7/8 x 1/4)	1

ITEM NO.	PART NO.	DESCRIPTION	NO. REQ'D
----------	----------	-------------	-----------

Fasteners

F002	10-24 Keps Nut	8
F004	1/4-20 Keps Nut	6
F009	5/16-18 Whiz Locknut	1
F012	3/8-16 Keps Nut	3
F025	10-24 x 3/8 PPHMS	2
F026	10-24 x 1/4 PPHMS	2
F034	5/16-18 x 3/4 Hex Bolt	1
F038	3/8-16 x 1 Hex Bolt	1
F040	3/8-16 x 1-1/2 Hex Bolt	1
F042	3/8-16 x 2-1/4 Hex Bolt	1
F054	AN960616 Washer	1
F067	3/16 x 3/16 x 1 Key	1
F074	1/4-20 x 3/8 Set Screw	2
F075	5/16-18 x 1/2 SQH Set Screw	2
F079	A/A66D Aluminum Pop Rivet	6
F085	3/16 Rivet Backup Washer	6
F102	10-24 x 1-1/2 PTHMS	2
F114	5/16-18 x 5/8 SQH Set Screw	2
F128	10-24 x 3/8 PTHMS	4
F217	7/16-14 Hex Nut	1
F218	7/16 Split Lock Washer	1
F219	7/16-14 x 1-1/4 Hex Bolt	1
F231	1/4 x 3/4 Woodruff Key (# 806)	1
F362	A/A62D Alum. Pop Rivet (3/16D x 13/32L)	2

* Service Part Only

** Plugs Blower when GHS is not in use. Furnished only with Mulching Decks, SD Decks used on a GHS Tractor, Rotary Broom Attachment and Snowblower Attachment. Use of this part may be replaced by installing Blower Lockout Kit (P/N 6541). See Page 70.

GHS GROUP

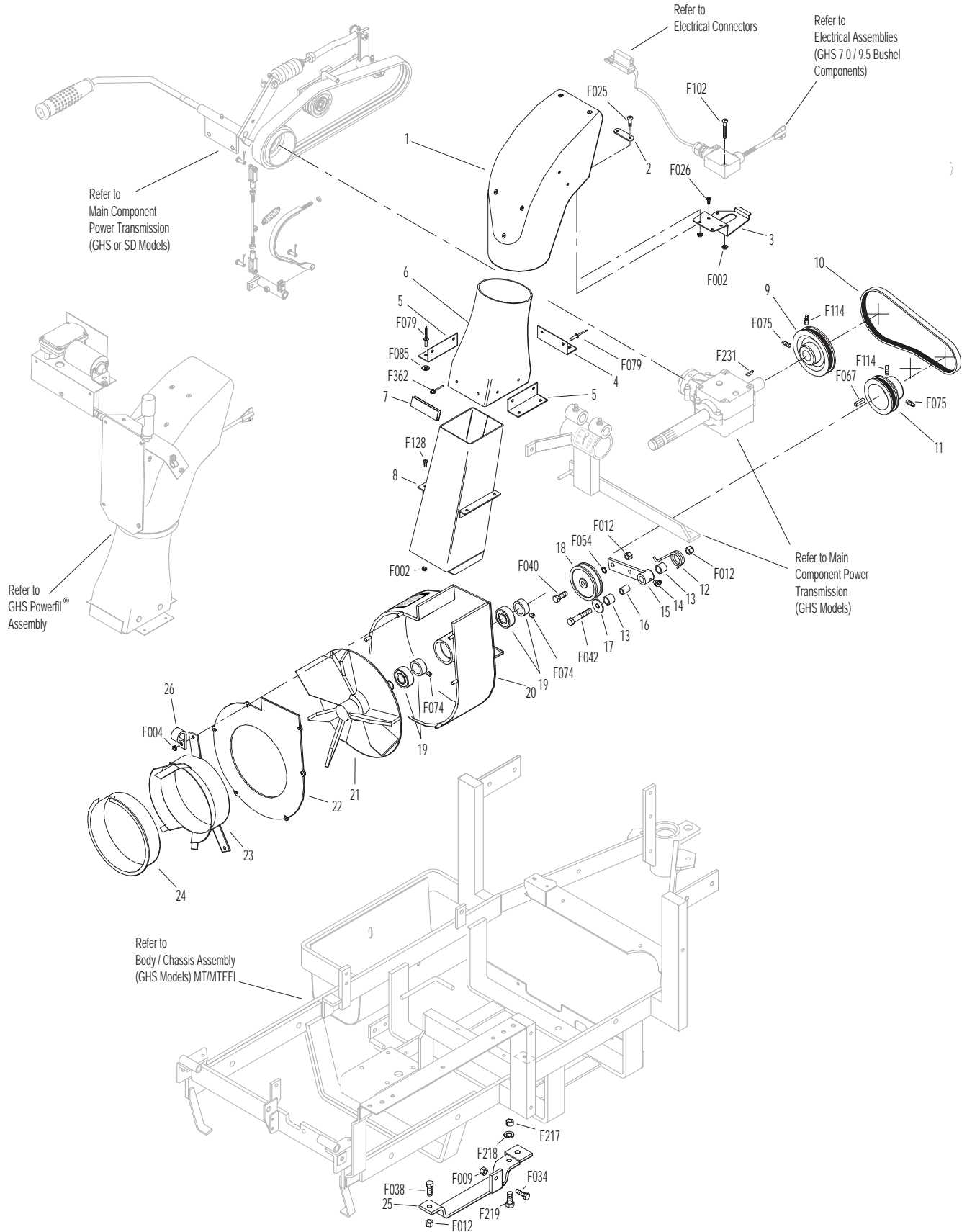

GHS POWERFIL® ASSEMBLY

ITEM NO.	PART NO.	DESCRIPTION	NO. REQ'D	ITEM NO.	PART NO.	DESCRIPTION	NO. REQ'D
GHS Powerfil® Assembly				Fasteners			
1	5557	Motor Mount, Powerfil®	1	F002		10-24 Keps Nut	10
2	5551-3	Bearing Cap, Powerfil®	1	F003		1/4-28 Hex Nut	3
3	5551-1	Pivot Bearing (#S3PP)	2	F025		10-24 x 3/8 PPHMS	4
4	5552	Ball Joint (1/4-28)	2	F054		AN960616 Washer	1
5	5518-2	Pivot, Delivery Spout	1	F085		#10 SAE Washer	1
6	5517-2	Pivot Mount	1	F101		10-24 x 1-1/4 SHC Screw	1
7	5558-1	Powerfil® Push Rod	1	F109		1/8 x 5/8 Roll Pin	1
8	5553-3	Bushing, Powerfil® Actuator	4	F129		10-24 x 1/2 PTHMS	4
9	5558-2	Powerfil® Actuator Rod	1	F261		AN960616L Washer	1
	5549	Actuator Rod Assembly (Includes Items # 4, 7-10 & F003)	*	F287		1/4-28 Keps Nut	1
10	5553-1	Spring, Powerfil® Actuator	2	* Service Part Only			
11	5554	Actuator Arm	1				
12	5519-3	Motor Mount Nut (5/8-24)	*				
13	5519-2	Motor Mount Washer	*				
14	5519	Actuator Motor (12/24V) (Includes Items # 12 & 13)	1				
15	5977	Grommet (1/2 x 7/8 x 1/16)	1				

GHS POWERFIL® ASSEMBLY

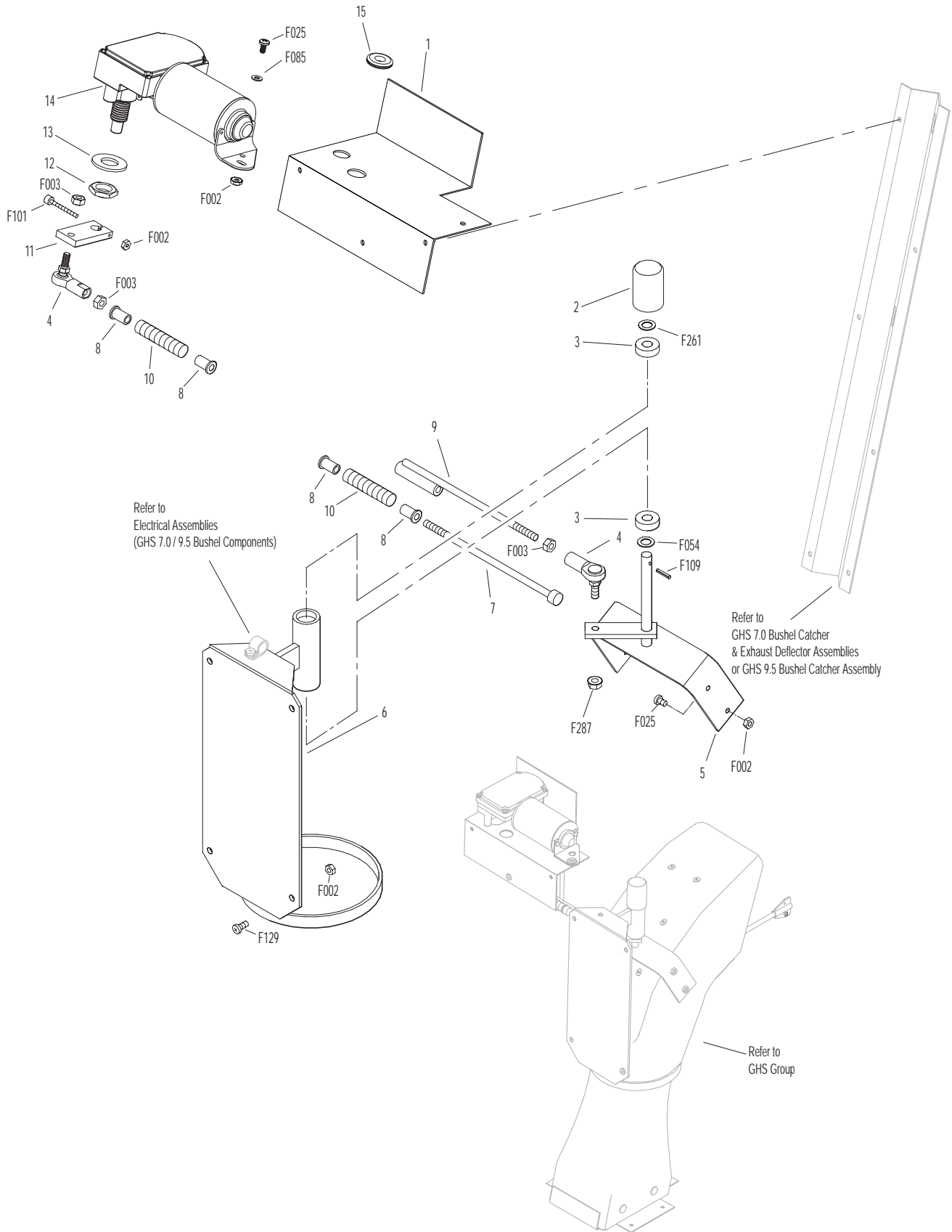

GHS 7.0 BUSHEL CATCHER & EXHAUST DEFLECTOR ASSEMBLIES

ITEM NO.	PART NO.	DESCRIPTION	NO. REQ'D	ITEM NO.	PART NO.	DESCRIPTION	NO. REQ'D
Upper Baffle Screen Assembly (Removable)				34	7557-10	7.0 Wire Harness Channel	1
1	7509-3	Channel Bottom	2	35	5976	Grommet (3/8 x 11/16)	1
2	7505	Mustache Spring	2	36	5976-2	Grommet (3/16 x 3/4)	1
3	7507	Screen Seal (27-1/2)	1	37	5522-2	Hinge Backup Plate, RH	1
4	7856-1	Edge Molding (26")	1	38	7508	Safety Latch	1
5	7509-2	Channel Top	2	39	7584	Reinforcing Strap	2
6	7512-2	Removable Screen (3/16 Holes) (Includes Items # 7, F025 & F190)	1**	40	7514-1	Backup Plate	1
7	7506	Knob (10-24) Threaded Insert	2	5598 Optional Dump Bag (Not Shown)			
8	7509-4	C-Channel	1	May be ordered as an option. Contact your Walker dealer. Not used with Power Dump Option.			
Exhaust Deflector Assembly				Fasteners			
9	7504-3	Hinge (27")	1	F002		10-24 Keps Nut	29
10	7504-1	Exhaust Deflector (Two Piece Set)	1	F004		1/4-20 Keps Nut	13
	7504	Exhaust Deflector Kit	*	F009		5/16-18 Whiz Locknut	2
11	7504-8	Deflector Mount Doubler	2	F020		5/16-18 ESNA Nut	2
GHS 7.0 Bushel Catcher Assembly				F025		10-24 x 3/8 PPHMS	4
12	5583	Handle	1	F026		10-24 x 1/2 PPHMS	4
13	5588	Rubber Bumper (.75 x .50)	2	F027		10-24 x 5/8 PPHMS	4
14	7522	Side Strap, Door (7.0)	2	F035		5/16-18 x 1-1/4 Hex Bolt	1
15	7610	Catcher Dump Plate	1	F037		10-24 x 5/8 PTH Screw	2
16	7610-1	Dump Plate Slide	2	F049		5/16 SAE Washer	4
17	7513-2	7.0 Mounting Frame Doubler	1	F069		3/32 x 1/2 Cotter Pin	2
18	5281-5	Clevis Pin (1/4 x 0.80)	2	F079		A/A66D Aluminum Pop Rivet	20
19	7503	Mounting Frame (7.0) (Includes Item # 21)	1	F085		3/16 Rivet Backup Washer	15
20	5522-1	Hinge Backup Plate, LH	1	F129		10-24 x 1/2 PTHMS	8
21	7503-9	Pivot Bushing (5/16 x 5/8)	2	F137		3/8-16 x 1/2 x 2 SHL Bolt	2
22	7510-1	7.0 Bushel Catcher, Including Door	1	F172		1/4-20 x 3/4 Carriage Bolt	2
	7502-1	7.0 Catcher, Without Powerfil® (Includes Door & Deflector)	*	F188		1/4-20 Self Locking Nut	11
	7502-2	7.0 Catcher (With Powerfil®) (Includes Door & Deflector)	*	F190		#10 Internal Star Lock Washer	2
23	7514-10	7.0 Door Frame, Catcher	1	F195		1/4-20 x 3/4 PPHMS SS	14
24	5155-12	5/16 Ball Stud	2	F196		1/4-20 x 1 PPHMS SS	4
25	5147	Spring Clip	4	F198		.625 x .250 x .040 Washer, SS	8
26	5155-2	Gas Spring Cover	2	F228		# 6 x 1/2 PPHSM Set Screw	2
27	5155	Gas Spring Assembly / Catcher Door (Includes Items # 24, 25, 29 & F049)	2	F230		1/4-20 x 1-1/4 PPHMS SS	1
28	5524-1	Flanged Hinge Bearing	2	F242		1/4-20 x 7/8 PPHMS SS	9
29	5155-13	3/4 Ball Stud	2	F252		10-24 x 3/4 PPHMS	1
30	5523-6	Gas Spring Plate	2	F255		5/16-18 x 1-1/2 Hex Bolt	1
31	7532	Handle, Catcher Lift	2	F329		.260 ID x 1.939 OD Washer	2
	7534	Catcher Handle Kit (Includes Items # 31, 32, F004 & F172)	*	F330		3/16 D x 21/32 Rivet, SS	2
32	7533	Backing Plate, Handle	2	F340		Rivet, Aluminum	4
33	5155-15	Box Support, Gas Spring	2	F351		Aluminum Pop Rivet	3
				* Service Part Only			
				** This screen can be replaced by P/N 7512-3 Removable Screen (3/4" hole) for improved air flow performance in wet conditions.			

Use only genuine **Walker®** replacement parts.

Effective Date 04-01-04

GHS 7.0 BUSHEL CATCHER & EXHAUST DEFLECTOR ASSEMBLIES

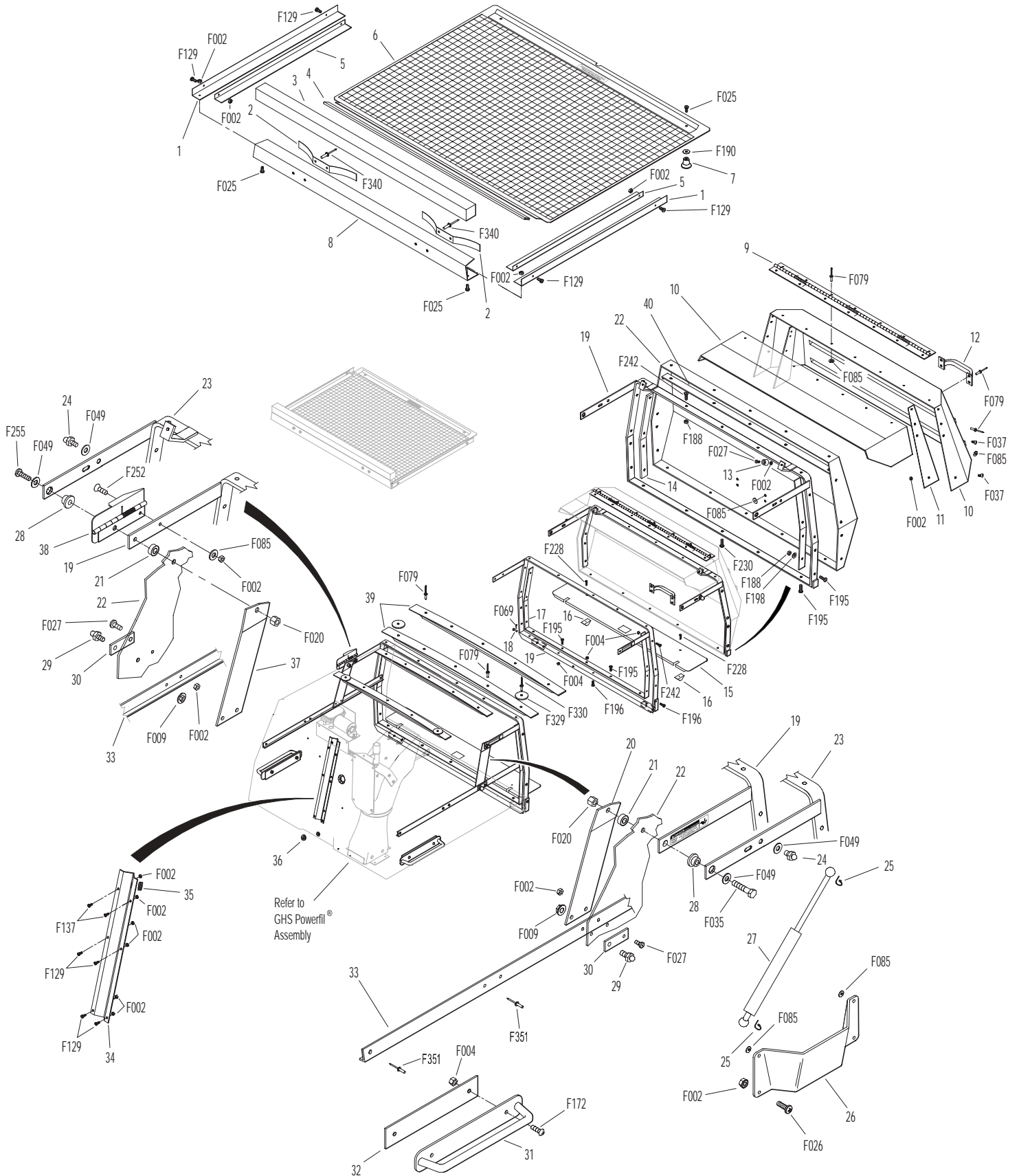

Effective Date 04-01-04

Use only genuine Walker® replacement parts.

GHS 9.5 BUSHEL CATCHER ASSEMBLY

ITEM NO.	PART NO.	DESCRIPTION	NO. REQ'D	ITEM NO.	PART NO.	DESCRIPTION	NO. REQ'D
GHS 9.5 Bushel Catcher Assembly				Fasteners			
May be ordered as a factory-installed option. Contact your Walker dealer.							
1	8514-11	9.5 Door Frame	1	F002		10-24 Keps Nut	14
2	8510-1	9.5 Bushel Catcher, Including Door	1	F004		1/4-20 Keps Nut	16
	8502-1	9.5 Catcher Without Powerfil® (Includes Door & Deflector)	*	F009		5/16-18 Whiz Locknut	2
	8502-2	9.5 Catcher With Powerfil® (Includes Door & Deflector)	*	F020		5/16-18 ESNA Nut	2
3	7514-1	Backup Plate	1	F026		10-24 x 1/2 PPHMS	4
4	5588	Rubber Bumper (.75 x .50)	2	F027		10-24 x 5/8 PPHMS	4
5	8516	Side Strap, Door / 9.5	2	F035		5/16-18 x 1-1/4 Hex Bolt	1
6	5583	Handle	1	F037		10-24 x 5/8 PTH Screw	2
7	5522-1	Hinge Backup Plate, LH	1	F049		5/16 SAE Washer	4
8	7503-9	Pivot Bushing (5/16 x 5/8)	2	F069		3/32 x 1/2 Cotter Pin	1
9	8503	Mounting Frame (Includes Item # 8)	1	F079		A/A66D Aluminum Pop Rivet	11
10	5155-12	5/16 Ball Stud	2	F085		3/16 Rivet Backup Washer	9
11	5147	Spring Clip	4	F129		10-24 x 1/2 PTHMS	4
12	5155	Gas Spring Assembly / Catcher Door (Includes Items # 10, 11, 15 & F049)	2	F172		1/4-20 x 3/4 Carriage Bolt	2
13	5155-2	Gas Spring Cover	2	F188		1/4-20 Self Locking Nut	16
14	5524-1	Flanged Hinge Bearing	2	F195		1/4-20 x 3/4 PPHMS SS	7
15	5155-13	3/4 Ball Stud	2	F196		1/4-20 x 1 PPHMS SS	3
16	5523-6	Gas Spring Plate	2	F198		.625 x .250 x .040 Washer, SS	5
17	7533	Backing Plate, Handle	2	F230		1/4-20 x 1-1/4 PPHMS SS	1
18	7532	Handle, Catcher Lift	2	F242		1/4-20 x 7/8 PPHMS SS	23
19	5155-15	Box Support, Gas Spring	2	F252		10-24 x 3/4 PPHMS	1
20	8117	9.5 Wire Harness Channel	1	F255		5/16-18 x 1-1/2 Hex Bolt	1
21	5976	Grommet (3/8 x 11/16)	2	F329		.260 ID x 1.939 OD Washer	2
22	5522-2	Hinge Backup Plate, RH	1	F330		3/16 D x 21/32 L Rivet, SS	2
23	7508	Safety Latch Hinge	1	F351		Aluminum Pop Rivet	3
24	7584	Reinforcing Strap	2	* Service Part Only			
25	5281-5	Clevis Pin (1/4 x .080)	2	NOTE: Refer to ELECTRICAL CONNECTORS , Page 58 for identification of all Electrical Wiring Service Parts.			
26	8513-3	9.5 Mounting Frame Doubler	1				

GHS 9.5 BUSHEL CATCHER ASSEMBLY

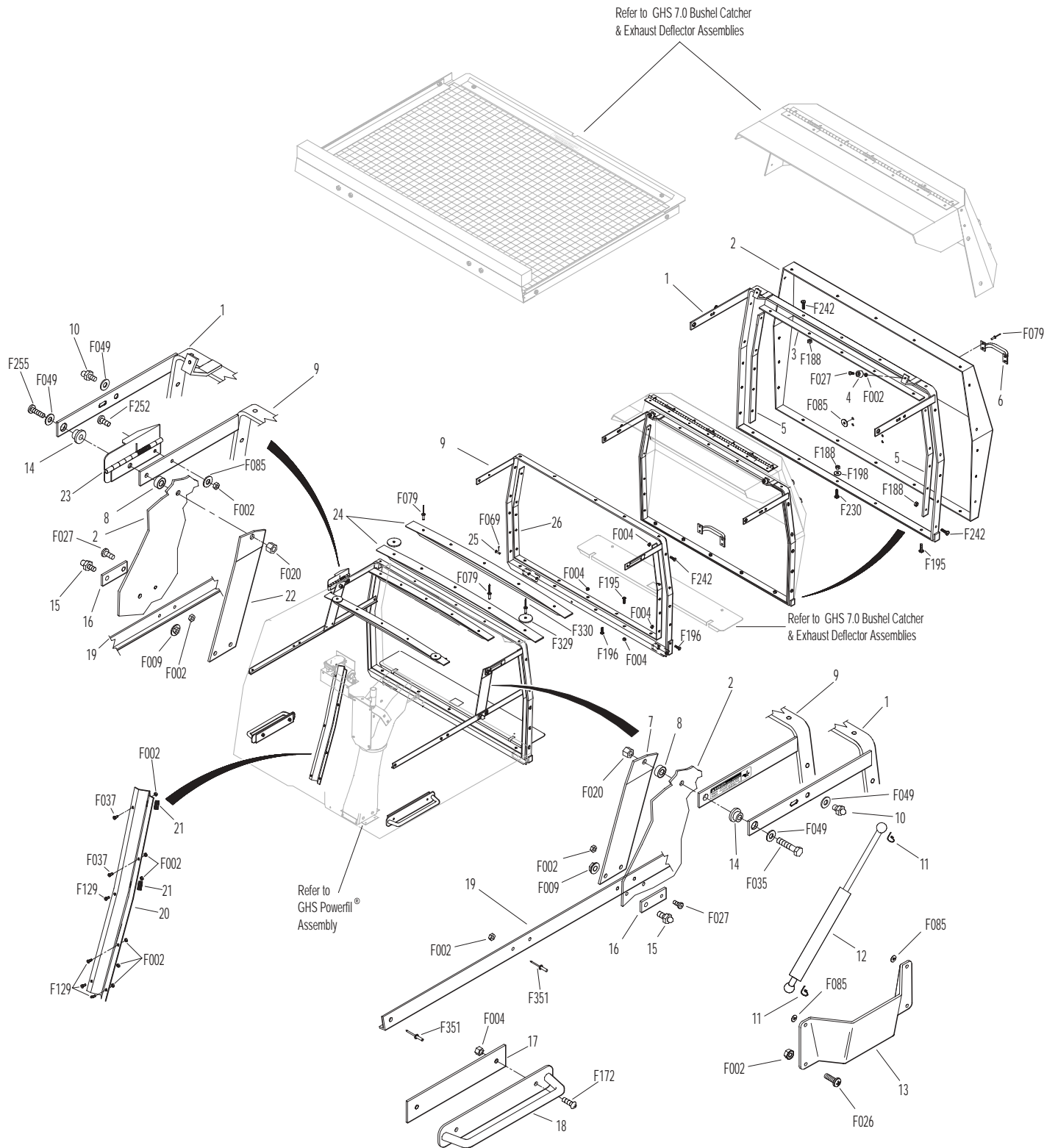

INSTRUMENT PANEL ASSEMBLY (MT)

ITEM NO.	PART NO.	DESCRIPTION	NO. REQ'D	ITEM NO.	PART NO.	DESCRIPTION	NO. REQ'D
Instrument Panel Assembly				20	8536	Warning Horn	1
1	7307-2	Instrument Panel Cover (Optional)	**	21	8960-15	Ignition Switch (with Keys) (Includes Items # 23, 24 & F349)	1
	8306-4	Instrument Panel Assembly (Includes Items # 2-12, 14, 16, 21, 22, 24-26, F062, F250, F251 & F349)	1	22	8996-2	Red Indicator Light Assembly (Includes Items # 25 & 26)	2
2	7307	Panel Frame	1	23	7854	Plastic Tip, Red	1
3	8823-2	Decal, Instrument Panel	1	24	8960-2	Ignition Key (1 Set)	*
4	8820-13	Panel Faceplate	1	25	8996-4	Red Indicator Lens	2
5	7386	Panel Gasket	1	26	8996-3	Indicator Bulb (Replacement for P/N 8996-2)	*
6	6941	Relay Switch (30/40 Amp)	2	Fasteners			
7	7941-3	Boot, Circuit Breaker	1	F004	1/4-20 Keps Nut		6
8	7941-5	Circuit Breaker (7 Amp)	1	F228	#6 x 5/8 PPHSMS, SS		8
9	5995-2	Switch Boot	1	F238	J Clip, Instrument Panel C15520-6A		8
10	5995	Toggle Switch (Off-On)	1	F250	6-32 x 3/8 PPHMS		2
11	8997	Voltmeter Gauge	1	F251	6-32 Keps Nut		2
12	8990-1	Hourmeter (SenDec)	1	F349	Washer .835 ID 1.122 OD, SS		1
13	5975-1	Cable Tie (18# x 3-3/4")	2	* Service Part Only			
14	8945-3	Wire Harness, Instrument Panel	1	** May be ordered as an option. Contact your Walker dealer.			
15	7307-16	Lining 1/8, Panel Box	1	NOTE: Refer to ELECTRICAL CONNECTORS , Page 58 for identification of all Electrical Wiring Service Parts.			
16	7391	Panel Box Mount Plate	2				
17	7977-1	Grommet (1/8 x 1-1/16)	1				
18	7307-1	Shock Mount (1.0 x .25)	3				
19	8385	Panel Box W/Graphic	1				

INSTRUMENT PANEL ASSEMBLY (MT)

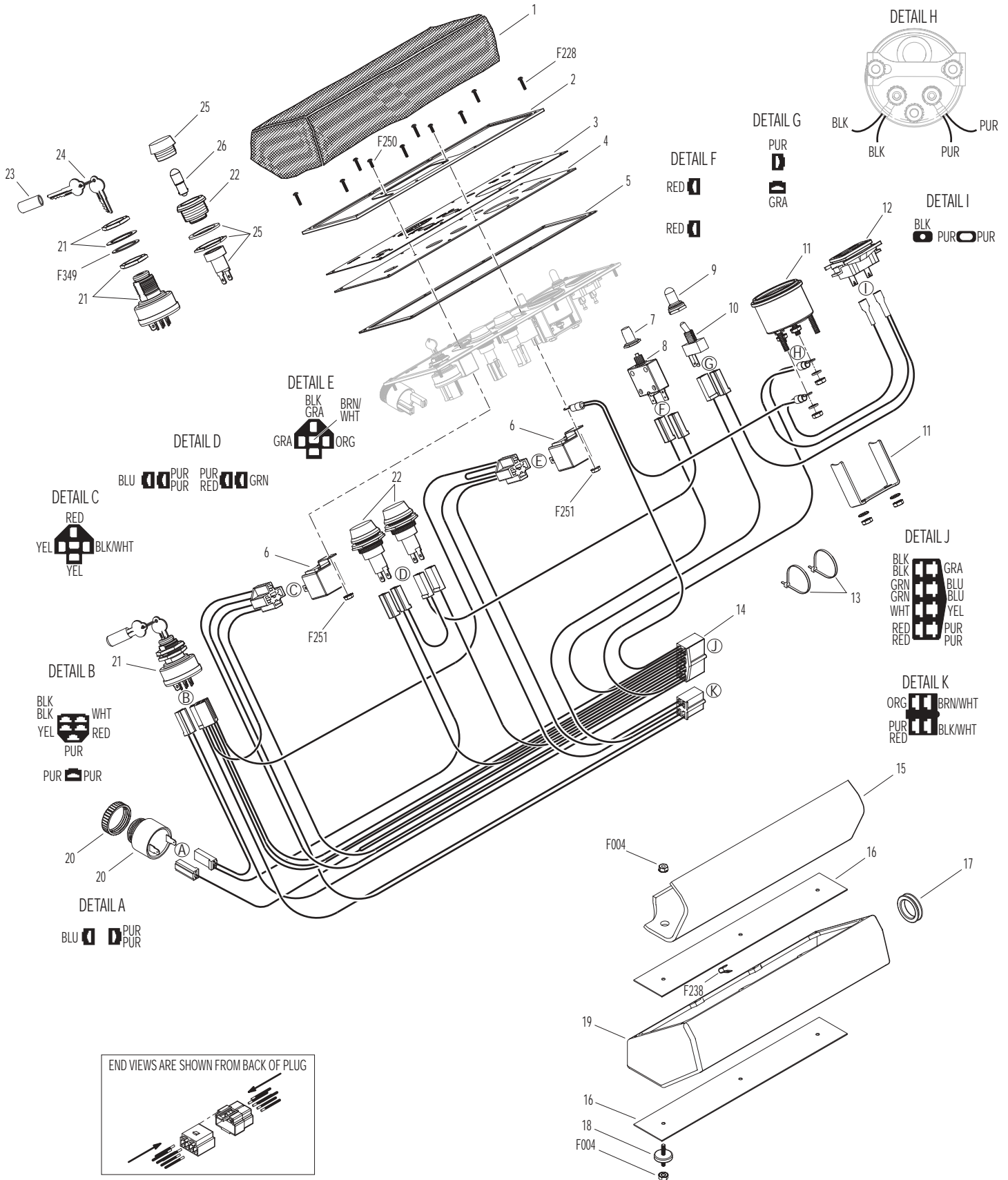

Effective Date 04-01-04

Use only genuine Walker® replacement parts.

INSTRUMENT PANEL ASSEMBLY (MTL)

ITEM NO.	PART NO.	DESCRIPTION	NO. REQ'D	ITEM NO.	PART NO.	DESCRIPTION	NO. REQ'D
Instrument Panel Assembly				20	8960-2	Ignition Key (1 Set)	*
1	7307-2	Instrument Panel Cover (Optional)	**	21	7854	Plastic Tip, Red	1
	8306-6	Instrument Panel Assembly (Includes Items # 2-5, 7-20, 26, 28, F228, F250, F251 & F349)	1	22	7307-1	Shock Mount (1.0 x .25)	3
2	7307	Panel Frame	1	23	7391	Panel Box Mount Plate	2
3	8823-4	Decal, Instrument Panel	1	24	8385	Panel Box W/Graphic	1
4	8820-2	Panel Faceplate	1	25	7977-1	Grommet (1/8 x 1-1/16)	1
5	7386	Panel Gasket	1	26	7307-16	Lining 1/8, Panel Box	1
6	8960-15	Ignition Switch (with Keys) (Includes Items # 20, 21 & F349)	1	27	8536	Warning Horn	1
7	8996-2	Red Indicator Light Assembly (Includes Items # 18 & 19)	2	28	6941	Relay Switch (30/40 Amp)	3
8	7941-3	Boot, Circuit Breaker	2	Fasteners			
9	7941-5	Circuit Breaker (7 Amp)	1	F002	10-24 Keps Nut		1
10	7941-2	Circuit Breaker (10 Amp)	1	F004	1/4-20 Keps Nut		6
11	8990-1	Hourmeter (SenDec)	1	F025	10-24 x 3/8 PPHMS		1
12	5995	Toggle Switch (Off-On)	1	F228	#6 x 5/8 PPH SMS, SS		8
13	5995-2	Switch Boot	1	F238	J Clip, Instrument Panel C15520-6A		8
14	7306-14	Water Temperature Gauge	1	F250	6-32 x 3/8 PPHMS		2
15	8997	Voltmeter Gauge	1	F251	6-32 Keps Nut		2
16	8945-4	Wire Harness, Instrument Panel	1	F349	Washer .835 ID, 1.122 OD, SS		1
17	5975-1	Cable Tie (18# x 3-3/4")	2	* Service Part Only			
18	8996-4	Red Indicator Lens	2	** May be ordered as an option. Contact your Walker dealer.			
19	8996-3	Indicator Bulb (Replacement for P/N 8996-2)	*	NOTE: Refer to ELECTRICAL CONNECTORS , Page 58 for identification of all Electrical Wiring Service Parts.			

INSTRUMENT PANEL ASSEMBLY (MTL)

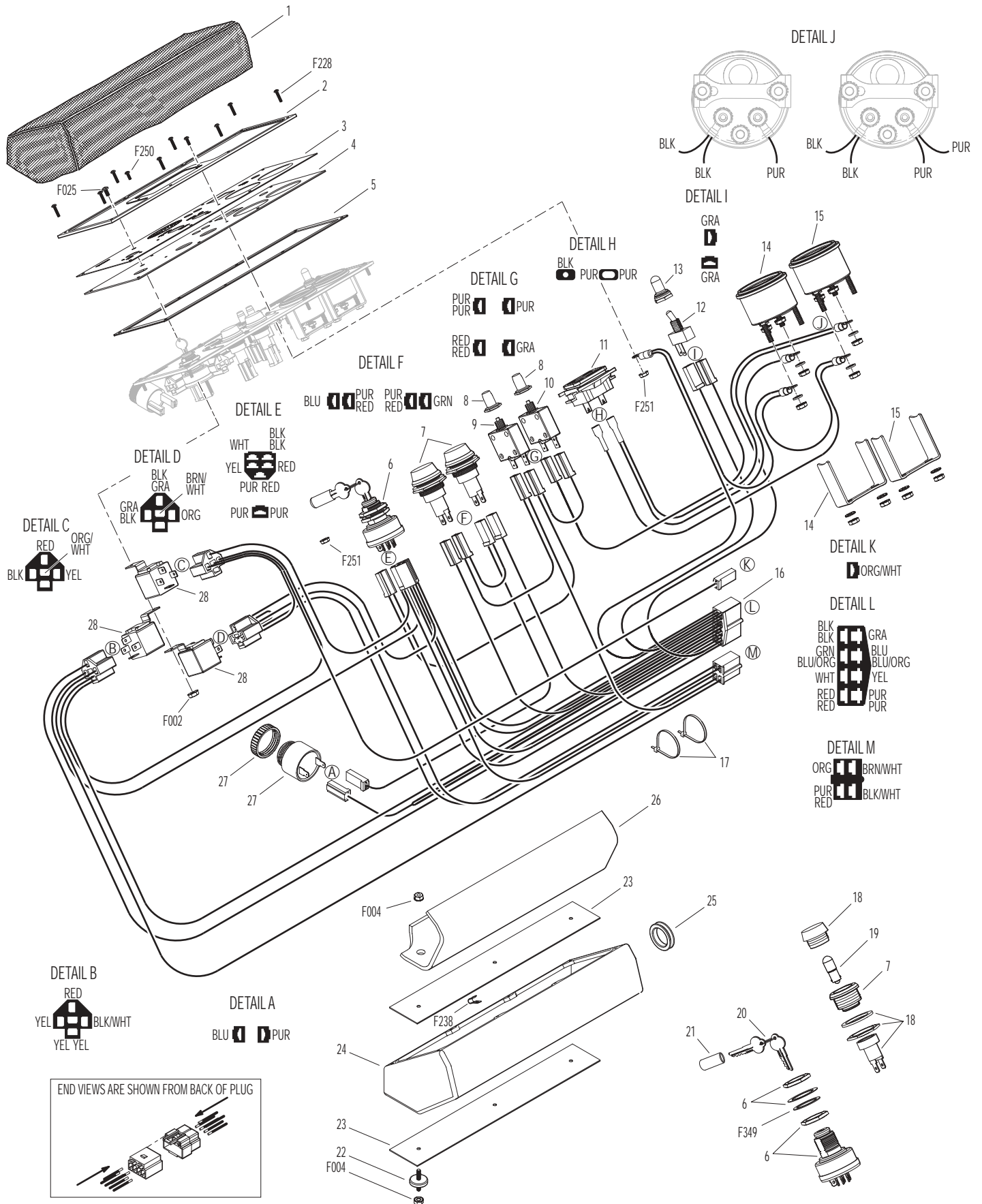

Effective Date 04-01-04

Use only genuine Walker® replacement parts.

INSTRUMENT PANEL ASSEMBLY (MTEFI)

ITEM NO.	PART NO.	DESCRIPTION	NO. REQ'D	ITEM NO.	PART NO.	DESCRIPTION	NO. REQ'D
Instrument Panel Assembly				20	8996-6	Amber Indicator Lens	1
1	7307-2	Instrument Panel Cover (Optional)	**	21	8996-10	Amber Indicator Light Assembly (Includes Items # 16 & 20)	1
	8306-5	Instrument Panel Assembly (Includes Items # 2-12, 14-21, 27-29, F228, F250, F251 & F349)	1	22	7307-1	Shock Mount (1.0 x .25)	3
2	7307	Panel Frame	1	23	7391	Panel Box Mount Plate	2
3	8823-3	Decal, Instrument Panel	1	24	8385	Panel Box W/Graphic	1
4	8820-16	Panel Faceplate	1	25	7977-1	Grommet (1/8 x 1-1/16)	1
5	7386	Panel Gasket	1	26	7307-16	Lining 1/8, Panel Box	1
6	8996-2	Red Indicator Light Assembly	2	27	8536	Warning Horn	1
7	8990-1	Hourmeter (SenDec)	1	28	8997	Voltmeter Gauge	1
8	5995-2	Switch Boot	1	Fasteners			
9	5995	Toggle Switch (Off-On)	1		F004	1/4-20 Keps Nut	6
10	6941	Relay Switch (30/40 Amp)	2		F228	#6 x 5/8 PPH SMS, SS	8
11	7941-3	Boot, Circuit Breaker	1		F238	J Clip, Instrument Panel C15520-6A	8
12	7941-5	Circuit Breaker (7 Amp)	1		F250	6-32 x 3/8 PPHMS	2
13	5975-1	Cable Tie (18# x 3-3/4")	2		F251	6-32 Keps Nut	2
14	8945-3	Wire Harness, Instrument Panel	1		F349	Washer .835 ID, 1.122 OD, SS	1
15	8996-4	Red Indicator Lens	2	* Service Part Only			
16	8996-3	Indicator Bulb (Replacement for P/N 8996-2)	*	** May be ordered as an option. Contact your Walker dealer.			
17	8960-2	Ignition Key (1 Set)	*	NOTE: Refer to ELECTRICAL CONNECTORS , Page 58 for identification of all Electrical Wiring Service Parts.			
18	7854	Plastic Tip, Red	1				
19	8960-15	Ignition Switch (with Keys) (Includes Items # 17, 18 & F349)	1				

INSTRUMENT PANEL ASSEMBLY (MTEFI)

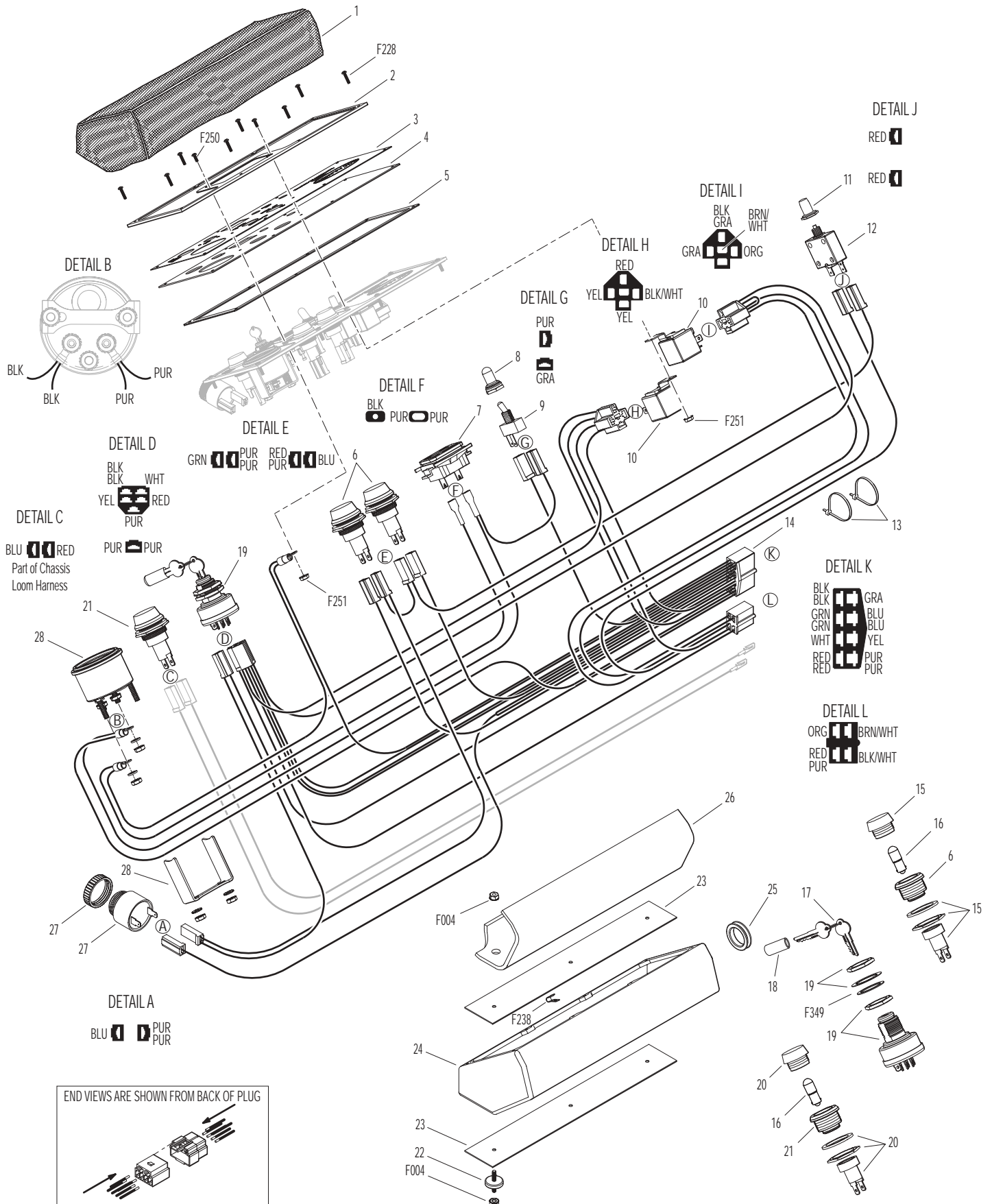

Effective Date 04-01-04

Use only genuine Walker® replacement parts.

ELECTRICAL ASSEMBLY (MT)

ITEM NO.	PART NO.	DESCRIPTION	NO. REQ'D	ITEM NO.	PART NO.	DESCRIPTION	NO. REQ'D
Harness Assembly				Fasteners			
1	5975-3	Cable Tie (50# x 7")	6	F002		10-24 Keps Nut	10
2	5942-4	PTO Safety Switch (Normal Open)	1	F004		1/4-20 Keps Nut	4
3	5833	Cable Clamp (1/4)	1	F009		5/16-18 Whiz Locknut	1
4	8940-3	Wire Harness	1	F019		1/4-20 ESNA Wing Nut	2
5	5832	Cable Clamp (1/2)	5	F025		10-24 x 3/8 PPHMS	4
6	7944	7.0 Wire Harness	1*	F026		10-24 x 1/2 PPHMS	3
	8950	9.5 Wire Harness	1*	F031		1/4-20 x 5/8 Hex Bolt	2
7	7833-2	Cable Clamp (1 x 1/4)	2	F032		1/4-20 x 3/4 Hex Bolt	2
8	6941	Relay Switch (30/40 Amp)	1	F050		1/4 SAE Washer	4
9	7948-1	Time Delay Module	1	F061		1/4 Star Lock Washer	1
10	7948-5	Time Delay Harness	1	F078		A/A64D Aluminum Pop Rivet	2
11	8941	Circuit Breaker (30 Amp) Auto Reset/Sealed	1	F079		A/A66D Aluminum Pop Rivet	2
12	8943	Positive Battery Lead Wire (Red)	1	F085		3/16 Rivet Backup Washer	1
13	5942-5	Safety Switch (Normal Open)	1	F093		5/16-18 x 1 Hex Bolt	1
14	5975-1	Cable Tie (18# x 3-3/4")	3	F124		10-32 x 3/8 Taptite Machine Screw	2
15	5941-5	Safety Switch (Normal Open)	1	F129		10-24 x 1/2 PTHMS	1
16	7203-6	Riser Plate, Seat Switch	1	F284		M6 x 1.0 x 8 SCH Screw	1
17	5977-6	Grommet (1 x 1-1/4)	1				
Battery Assembly				* Used on GHS Models with 7.0 Bushel Catcher only. When Optional GHS 9.5 Bushel Catcher is purchased, this part is replaced by P/N 8950 (9.5 Catcher Wire Harness).			
18	6923	Negative Battery Cable	1	NOTE: Refer to ELECTRICAL CONNECTORS , Page 58 for identification of all Electrical Wiring Service Parts.			
19	5933	Battery Terminal Insul., Red (+)	1				
20	5844	Battery Hold-Down Bar	1				
21	5839	Hook Bolt	2				
22	6392	Battery Protector Plate	1				
23	7390-1	Battery Pan	1				
24	5910	Battery (12V U1-SP30, Dry)	1				
25	5932	Battery Terminal Insul., Black (-)	1				
26	5975-5	Wire Clip, Self-Mount	1				

ELECTRICAL ASSEMBLY (MTL)

ITEM NO.	PART NO.	DESCRIPTION	NO. REQ'D	ITEM NO.	PART NO.	DESCRIPTION	NO. REQ'D
Electrical Assembly				Fasteners			
1	8940-4	Wiring Harness	1		F002	10-24 Keps Nut	7
2	5975-3	Cable Tie (50# x 7")	1		F004	1/4-20 Keps Nut	1
3	8940-5	Jumper Wire, Resistor	1		F025	10-24 x 3/8 PPHMS	3
4	6941	Relay Switch (30/40 Amp)	1		F026	10-24 x 1/2 PPHMS	2
5	5975-1	Cable Tie (18# x 3-3/4")	7		F050	1/4 SAE Washer	1
6	8941	Circuit Breaker (30 Amp) Auto Reset/Sealed	1		F061	1/4 Star Washer	1
7	7433	Resistor, Ceramic / .4 OHM	1		F090	1/4-20 x 2-1/2 Hex Bolt	1
8	7306-10	Switch (235 Deg., 1/4-18 NPT)	1		F116	1/4-20 x 1-1/4 Hex Bolt	1
9	7306-11	Switch (205 Deg., 3/8-18 NPT)	1		F182	1/4 x 5/8 x 1/8 Washer	1
10	5975-7	Cable Tie (50# x 11")	2		F188	1/4-20 Self-Locking Nut	1
11	7428-1	Fan Control Module W/P Plug	1				

NOTE: Refer to **ELECTRICAL CONNECTORS**, Page 58 for identification of all Electrical Wiring Service Parts.

ELECTRICAL ASSEMBLY (MTEFI)

ITEM NO.	PART NO.	DESCRIPTION	NO. REQ'D	ITEM NO.	PART NO.	DESCRIPTION	NO. REQ'D
Electrical Assembly				Fasteners			
1	8940-16	Wire Harness, Ext. Fuel Pump	1	F002		10-24 Keps Nut	2
2	5975-1	Cable Tie (18# x 3-3/4")	1	F063		3/8 Internal Star Lock Washer	1
3	NS	Fuse Holder (Kohler)	3	F103		10-24 x 2 PTHMS	1
4	6941-4	30 Amp Fuse	1	F106		3/8-16 x 5/8 Hex Bolt	1
5	NS	Relay (Kohler)	1	F284		M6 x 1.0 x 8 SHC Screw	1
6	6941-1	20 Amp Fuse	1	F361		10-24 x 2-1/2 Hex Bolt	1
7	6941-3	10 Amp Fuse	1				
8	NS	ECU Harness Clip	1				
9	NS	ECU (Kohler)	1				
10	5975-8	Cable Tie (50# x 17-1/2")	1				

NOTE: Refer to **ELECTRICAL CONNECTORS**, Page 58 for identification of all Electrical Wiring Service Parts.

ELECTRICAL ASSEMBLY (MTEFI)

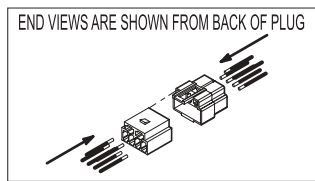
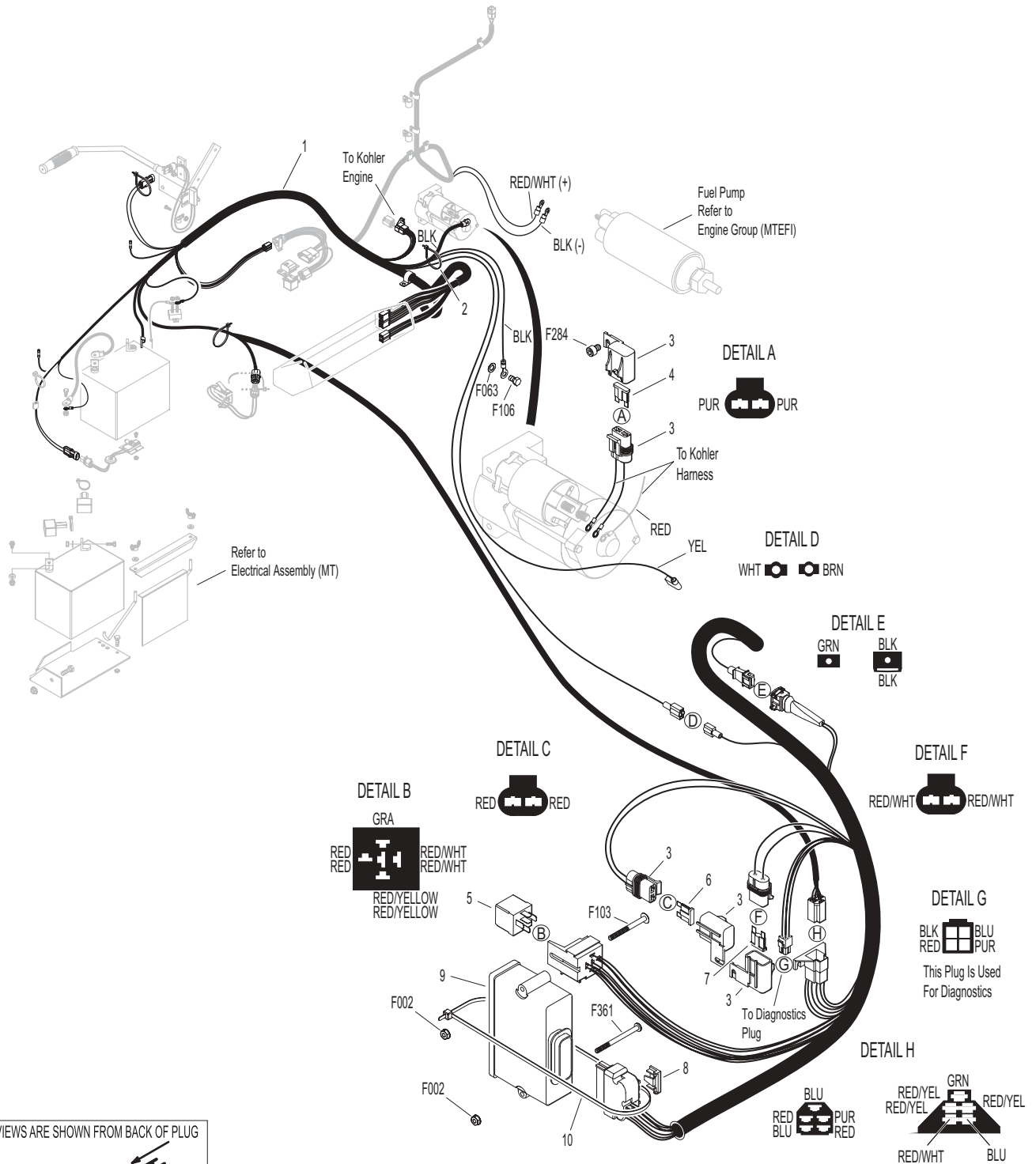

Effective Date 04-01-04

Use only genuine Walker® replacement parts.

ELECTRICAL ASSEMBLIES (GHS 7.0 / 9.5 BUSHEL COMPONENTS)

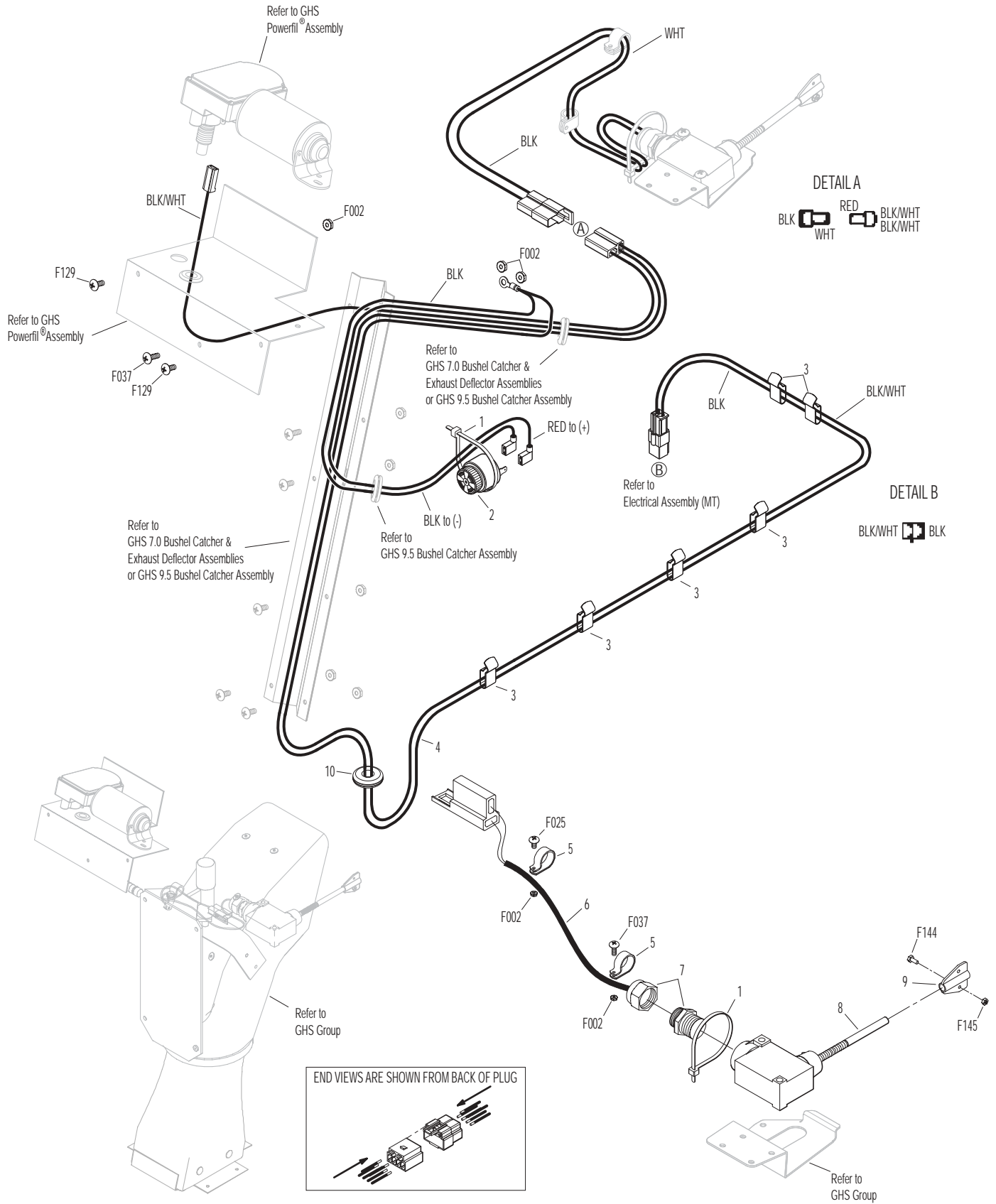

ELECTRICAL CONNECTORS

ITEM NO.	PART NO.	DESCRIPTION	NO. REQ'D	ITEM NO.	PART NO.	DESCRIPTION	NO. REQ'D
Electrical Wiring Service Parts				29	7942-1	2-Way Locking Connector, Female	*
1	5996-1	16-14 GA Butt Connector	*	30	7942-2	2-Way Connector, Male	*
2	5996-11	12-10 GA Butt Connector	*	31	7942-3	2-Way Connector, Female	*
3	7942-14	14-16 GA Shrink Connector	*	32	7942-10	2-Way Locking Connector, Male	*
4	7942-13	10-12 GA Shrink Connector	*	33	5940-8	3-Way Connector, Male	*
5	5995-1	Wire Terminal Adapter	*	34	7942-9	3-Way Connector, Male	*
6	5996-4	16-14 GA Bullet Conn., Male	*	35	8944	3-Way Locking Connector, Male	*
7	5996-5	16-14 GA Bullet Conn., Female	*	36	8944-1	3-Way Locking Connector, Female	*
8	5940-4	16-14 GA Spg. Loaded Term., Female	*	37	7942-11	4-Way Connector, Male	*
9	5940-7	Wire Clip, Female	*	38	7942-12	4-Way Connector, Female	*
10	5996	1/4 x 16-14 GA QKS Term., Female	*	39	7942-5	5-Way Connector, Male	*
11	5996-2	3/16 x 22-18 GA QKS Term., Female	*	40	5940-2	5-Way Connector, Male	*
12	7996	3/16 x 16-14 GA QKS Term., Female	*	41	8942-1	5-Way Connector, Female	*
13	5940-5	16-14 GA Spg. Loaded Term., Male	*	42	7942-6	6-Way Connector, Male	*
14	5996-0	1/4 x 22-18 GA QKS Term., Male	*	43	7942-7	6-Way Connector, Male	*
15	5996-18	16-14 GA Ring Term. (#8) Nylon Insulated	*	44	7942-8	8-Way Connector, Male	*
16	7996-1	1/4 x 16-14 GA QKS Term., Male	*	45	8942-2	8-Way Connector, Female	*
17	5996-8	6 GA Ring Lug (5/16)	*	46	8942-3	5-Way Connector, Male	*
18	5996-9	22-18 GA Ring Term., #10	*	47	5940-9	3-Way Connector (M)	*
19	5996-10	16-14 GA Ring Term. (5/16)	*	48	7942-15	6-Way Connector (Female)	*
20	5996-12	12-10 GA Ring Term. (5/16)	*	49	7940-3	Packard Plug (Male)	*
21	5996-13	16-14 GA Ring Term., # 10	*	50	7940-4	Packard Plug (Female)	*
22	5996-15	12-10 GA Ring Term. (1/2)	*	* Service Part Only			
23	5996-16	6 GA Ring Terminal (1/4)	*	NOTE: Not all Electrical Connectors are used with all assemblies.			
24	5996-17	16-14 GA Ring Term. (1/4)	*	NOTE: Refer to ELECTRICAL ASSEMBLY , Page 50 for locations of Wiring Harness and of all Electrical Wiring Service Parts.			
25	5996-20	12-10 GA Ring Term. (1/4)	*				
26	5996-21	12-10 GA Ring Term., #10	*				
27	7942-4	Single Connector, Male	*				
28	8942	2-Way Connector, Male	*				

ELECTRICAL CONNECTORS

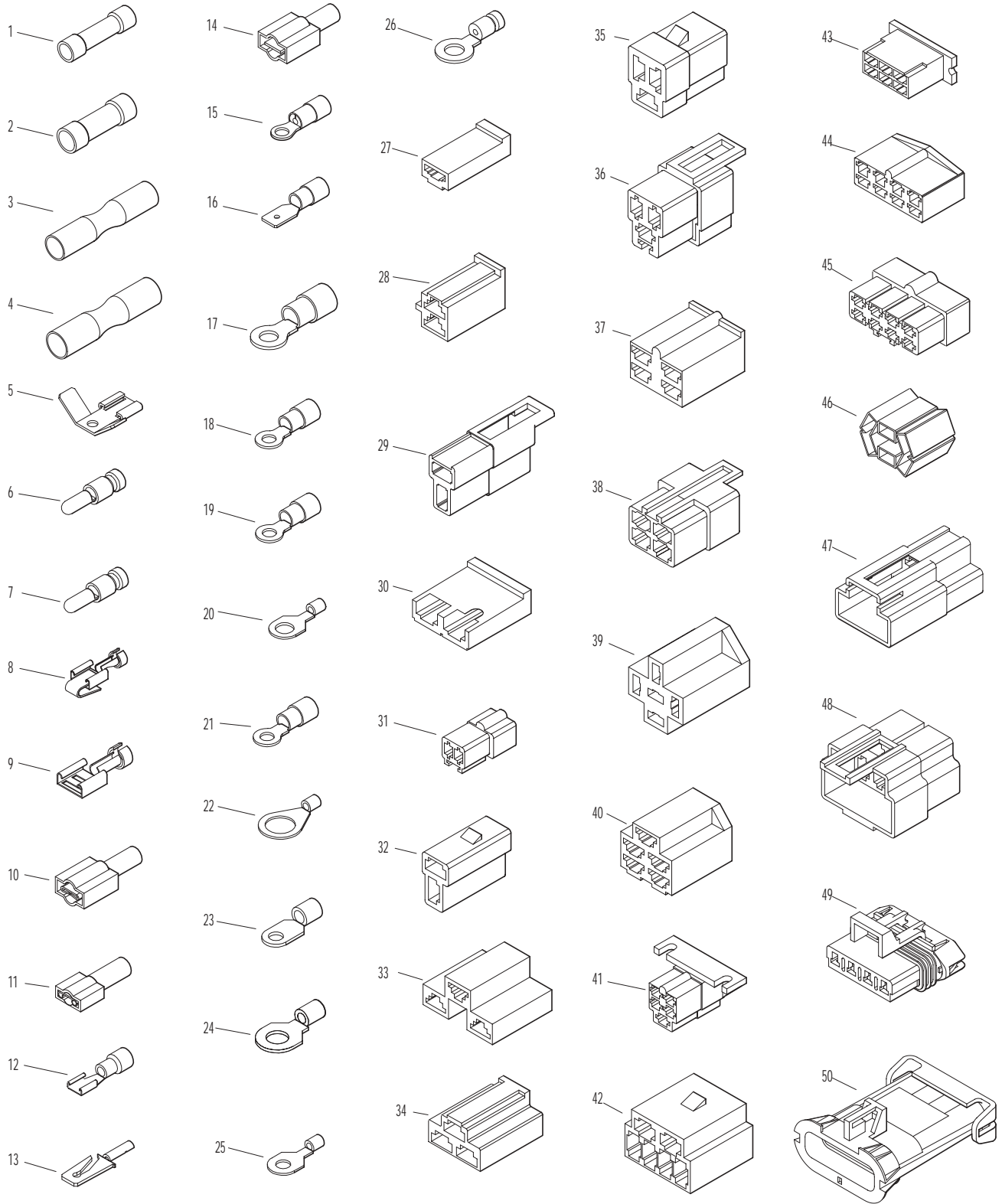

POWER DECK LIFT KIT

ITEM NO.	PART NO.	DESCRIPTION	NO. REQ'D	ITEM NO.	PART NO.	DESCRIPTION	NO. REQ'D
Kit 8655 Power Deck Lift Option / Kit Includes Items # 1-30, fasteners listed and instructions. May be ordered as a dealer-installed option. Contact your Walker dealer.				Fasteners			
1	8628	Linear Actuator (Includes Items 29, 30 & F320)	1	F002		10-24 Keps Nut	1
2	8655-8	Clamp Bar	1	F004		1/4-20 Keps Nut	9
3	7503-10	Actuator Drive Bushing	1	F009		5/16-18 Whiz Locknut	6
4	8655-11	Bushing (5/8 x 5/16 x 1-1/16)	1	F025		10-24 x 3/8 PPHMS	1
5	8655-10	Bushing (5/8 x 5/16 x 1-1/16)	1	F029		1/4-20 x 1/2 Hex Bolt	8
6	8655-7	Arm, Deck Lift	1	F032		1/4-20 x 3/4 Hex Bolt	1
7	8655-9	Cable Pull	1	F050		1/4 SAE Washer	1
8	8655-12	Bushing (3/4 x 1/4 ID x 3/4)	1	F061		1/4 Star Lock Washer	1
9	5977-1	Grommet (1/8 x 3/8)	1	F068		1/8 x 1 Cotter Pin	1
10	8649	Wire Harness	1	F069		3/32 x 1/2 Cotter Pin	2
11	5975-5	Wire Clip, Self Mount	1	F093		5/16-18 x 1 Hex Bolt	2
12	6623	Toggle Switch	1	F134		AN960816L Washer	1
13	5996-21	12-10 GA Ring Terminal (# 10)	*	F179		1/4-20 x 1 Hex Bolt	1
14	8655-1	Hitch Pin/Cotterless (5/8)	2	F316		5/16-18 x 1-3/4 Hex Bolt	2
15	8655-6	Lift Chain	2	F320		1/8 x 3/4 Split Spring Pin	*
16	8655-5	Cable Mount	2				
17	5996-20	12-10 GA Ring Terminal (1/4)	*				
18	7942-10	2-Way Locking Connector (M)	*				
19	5940-4	16-14 GA Spring-Loaded Terminal (F)	*				
20	8655-3	Cable LH (48")	1				
21	8655-2	Cable RH (38.5")	1				
22	8654	Decal, Deck Lift	1				
23	6623-1	Switch Boot	1				
24	6832	Cable Clamp (9/16 x 1/4)	1				
25	5832	Cable Clamp (1/2)	1				
26	8655-22	Base, Deck Lift	1				
27	8655-4	Clevis Pin (5/16 x 3/4)	2				
28	5975-3	Cable Tie (#50 x 7")	3				
29	7942-1	2-Way Locking Connector (F)	*				
30	5940-5	16-14 GA Spring-Loaded Terminal (M)	*				

* Service Part Only

NOTE: Power Deck Lift is not compatible with Comfort Seat or Suspension Seat.

POWER DECK LIFT KIT

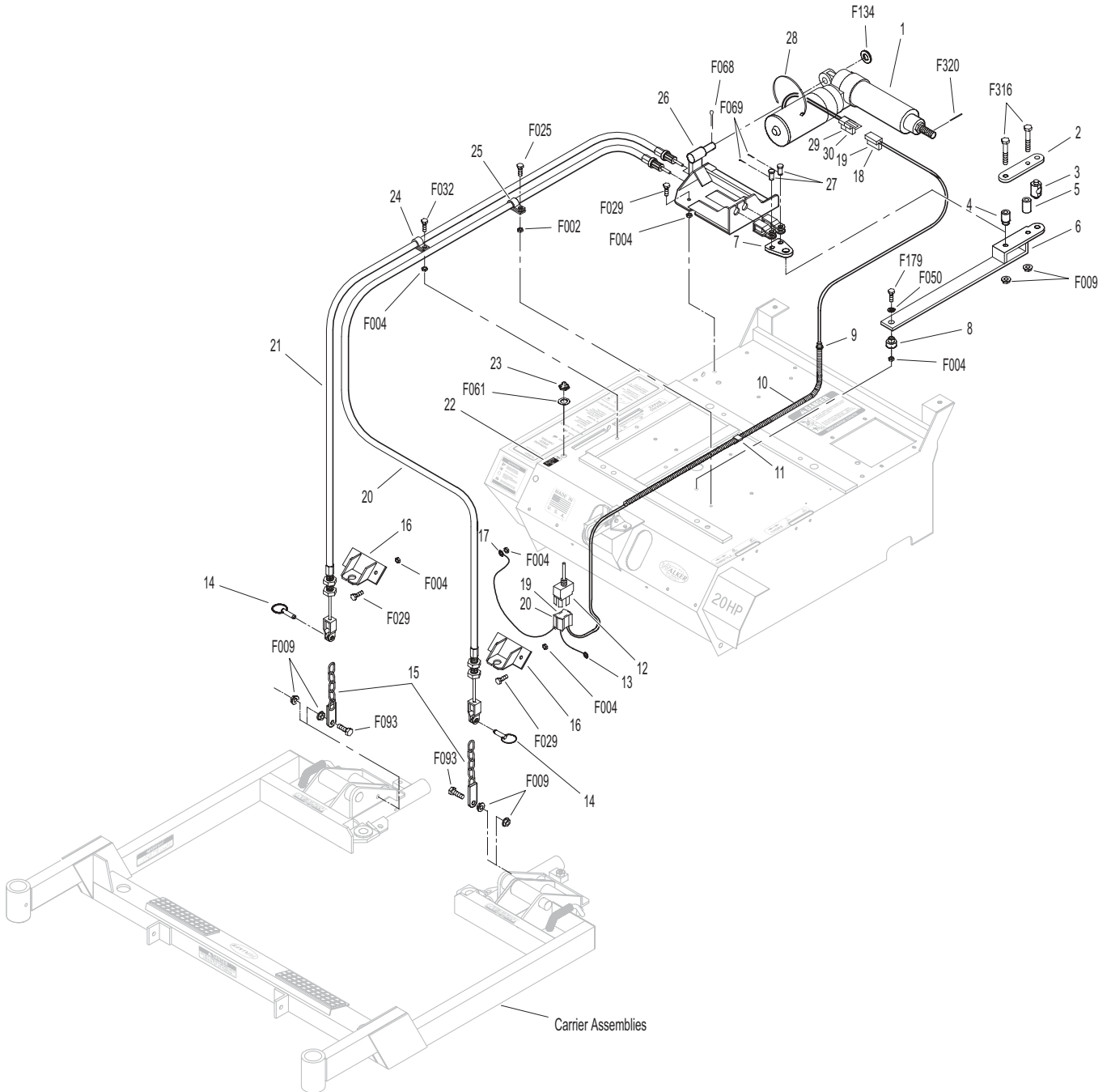

ARMREST KIT / TOUCH-UP PAINT

ITEM NO.	PART NO.	DESCRIPTION	NO. REQ'D	ITEM NO.	PART NO.	DESCRIPTION	NO. REQ'D
Kit 5885 Armrest Option / Kit Includes Items # 1-5, fasteners listed and instructions. May be ordered as a dealer-installed option. Contact your Walker dealer.				Touch-Up Paint			
1	5886-1	Armrest, RH	1	6	5866	Touch-Up Paint, Yellow (12 oz. Aerosol)	
2	5886-6	Cover Plate, RH	1	7	5867	Touch-Up Paint, Grey (12 oz. Aerosol)	
3	5887	Mounting Bracket	1	Fasteners			
4	5886-5	Cover Plate, LH	1	F305	1/4-20 x 3/8 SH Cap Screw		2
5	5886-2	Armrest, LH	1	F306	3/8-16 x 3/4 Hex Bolt		4
	5888	Armrest Hardware Kit (Includes Items # F305, F306, F307 & F308)	*	F307	#10 x 5/8 PPHST Screw		2
				F308	1-1/4 x 1-5/8 Wave Spring Washer		2
				* Service Part Only			

ARMREST KIT / TOUCH-UP PAINT

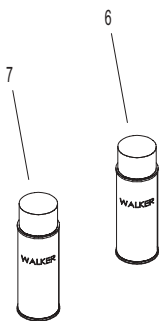
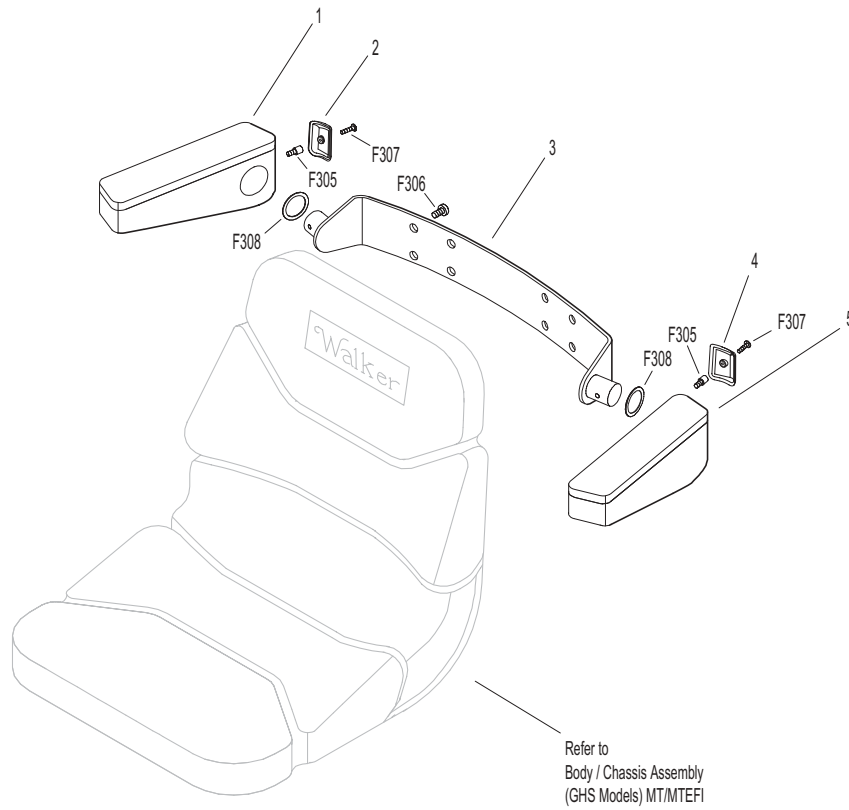

COMFORT SEAT / ARMREST KIT

ITEM NO.	PART NO.	DESCRIPTION	NO. REQ'D
----------	----------	-------------	-----------

Kit 6103-5 Comfort Seat Kit (Cordura)

Includes Items # 1, 6, fasteners listed and instructions. May be ordered as a dealer-installed option. Contact your Walker dealer.

1	6103-5	Comfort Seat	1
2	7203	Seat Spring Plate	*
3	7223	Compression Spring (1/2 x 1)	*
4	7846	Rubber Washer (3/8 x 1-1/4 x 1/8)	*
5	7204	Shoulder Bolt, Seat Mount	*
6	7203-6	Riser Plate, Seat Switch	**
7	7845	Rubber Bumper (1.375 x .63)	*
8	7440-5	Shock Mount (1-1/4 x 2)	*

Kit 6103-17 Armrest Option / Kit

Includes Items # 9, 10 and instructions. Item # 9 is the **Right** side armrest only. Item # 10 is the **Left** side armrest only. Sold only as a complete set and may be ordered together as a factory-installed option or as a kit for dealer installation. Contact your Walker dealer.

9	6103-42	Armrest, RH/Cordura	1
10	6103-41	Armrest, LH/Cordura	1

ITEM NO.	PART NO.	DESCRIPTION	NO. REQ'D
----------	----------	-------------	-----------

Fasteners

F009	5/16 - 18 Whiz Locknut	*
F026	10-24 x 1/2 PPHMS	2
F227	3/8-1-1/4 x 1/8 Plastic Washer	*

* Reuse existing parts from Seat Assembly. Refer to **BODY / CHASSIS ASSEMBLY (GHS MODELS) MT/MTEFI**, Page 4.

** Only one Riser Plate is included with kit. One is reused from Seat Assembly. Refer to **BODY / CHASSIS ASSEMBLY (GHS MODELS) MT/MTEFI**, Page 4.

COMFORT SEAT / ARMREST KIT

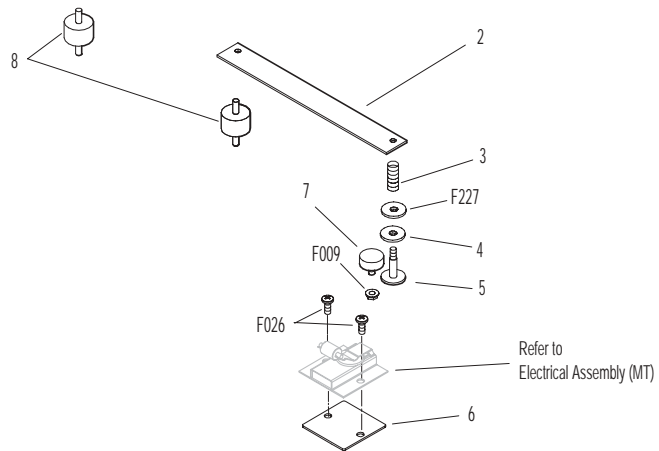
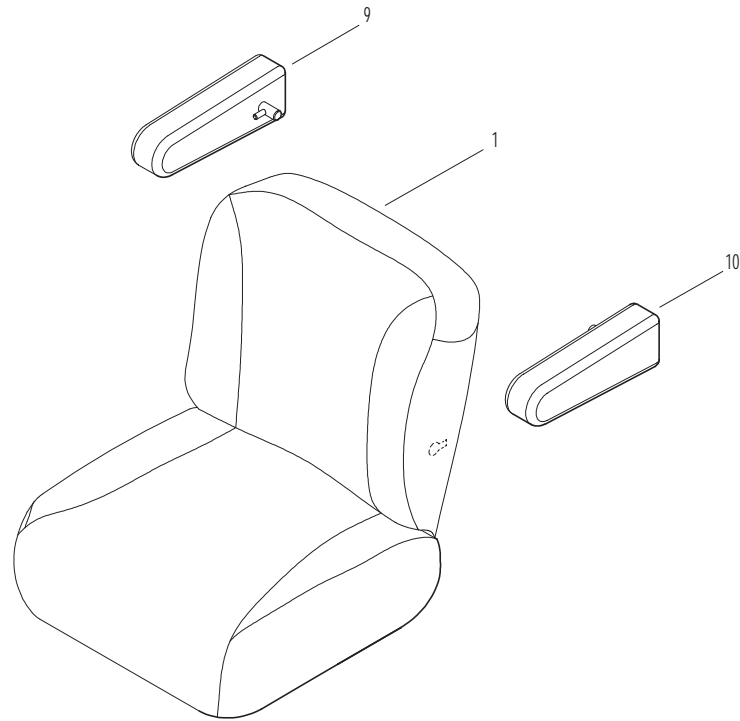

SUSPENSION SEAT KIT

ITEM NO.	PART NO.	DESCRIPTION	NO. REQ'D
----------	----------	-------------	-----------

Kit 6103-9 Armrest Kit

Includes Items # 1-6 and instructions. May be ordered as a factory-installed option or as a kit for dealer installation. Contact your Walker dealer.

1	6103-92	Armrest, RH/SS	1
2	NS	5/8 Nut Cover	4
3	NS	7/16-20 x 13/4 HHCS	4
4	NS	3/8 SAE Washer	4
5	NS	Bushing, 3/4 x 3/4	4
6	6103-91	Armrest, LH/SS	1

Kit 6103-25 Suspension Seat Option / Kit

Includes Items # 7-9, 11-13, 17, 20, fasteners listed (except as indicated; refer to **NOTE**) and instructions. May be ordered as a factory-installed option or as a kit for dealer installation. Contact your Walker dealer.

7	6103-11	Suspension Seat	1
8	5941-5	Safety Switch (Normal Open)	*
9	6103-33	Seat Mount Plate, LH	1
10	7223	Compression Spring (1/2 x 1)	2
11	5975-3	Cable Tie (50# x 7")	2
12	5975-1	Cable Tie (18# x 3-3/4")	1
13	6103-23	Wire Harness, Suspension Seat	1
14	7846	Rubber Washer (3/8 x 1-1/4 x 1/8)	2
15	7204	Shoulder Bolt, Seat Mount	2
16	5453-20	Steering Lever Handle (+1"), Adj.	2
17	5977-5	Grommet	1
18	5841	Retainer Washer	2
19	7845	Rubber Bumper (1.375 x 0.63)	2
20	7440-5	Shock Mount (1-1/4 x 2)	2
21	6103-34	Seat Mount Plate, RH	1

ITEM NO.	PART NO.	DESCRIPTION	NO. REQ'D
----------	----------	-------------	-----------

Fasteners

F002	10-24 Keps Nut	4
F009	5/16-18 Whiz Locknut	4
F026	10-24 x 1/2 PPHMS	4
F168	5/16 Split Lock Washer	4
F227	3/8 x 1-1/4 x 1/8 Washer (Plastic)	2
F357	M8 x 16 Hex Bolt	2
F358	M8 x 25 Hex Bolt	2

* Only one switch is included with kit. One is reused from Seat Assembly. Refer to **BODY / CHASSIS ASSEMBLY (GHS MODELS) MT/MTEFI**, Page 4.

NOTE: Reuse items # 8, 10, 14-16, 18, two (2) each of the F002, F009 and F026 fasteners, and item # F227 from Seat Assembly. Refer to **BODY / CHASSIS ASSEMBLY (GHS MODELS) MT/MTEFI**, Page 4.

SUSPENSION SEAT KIT

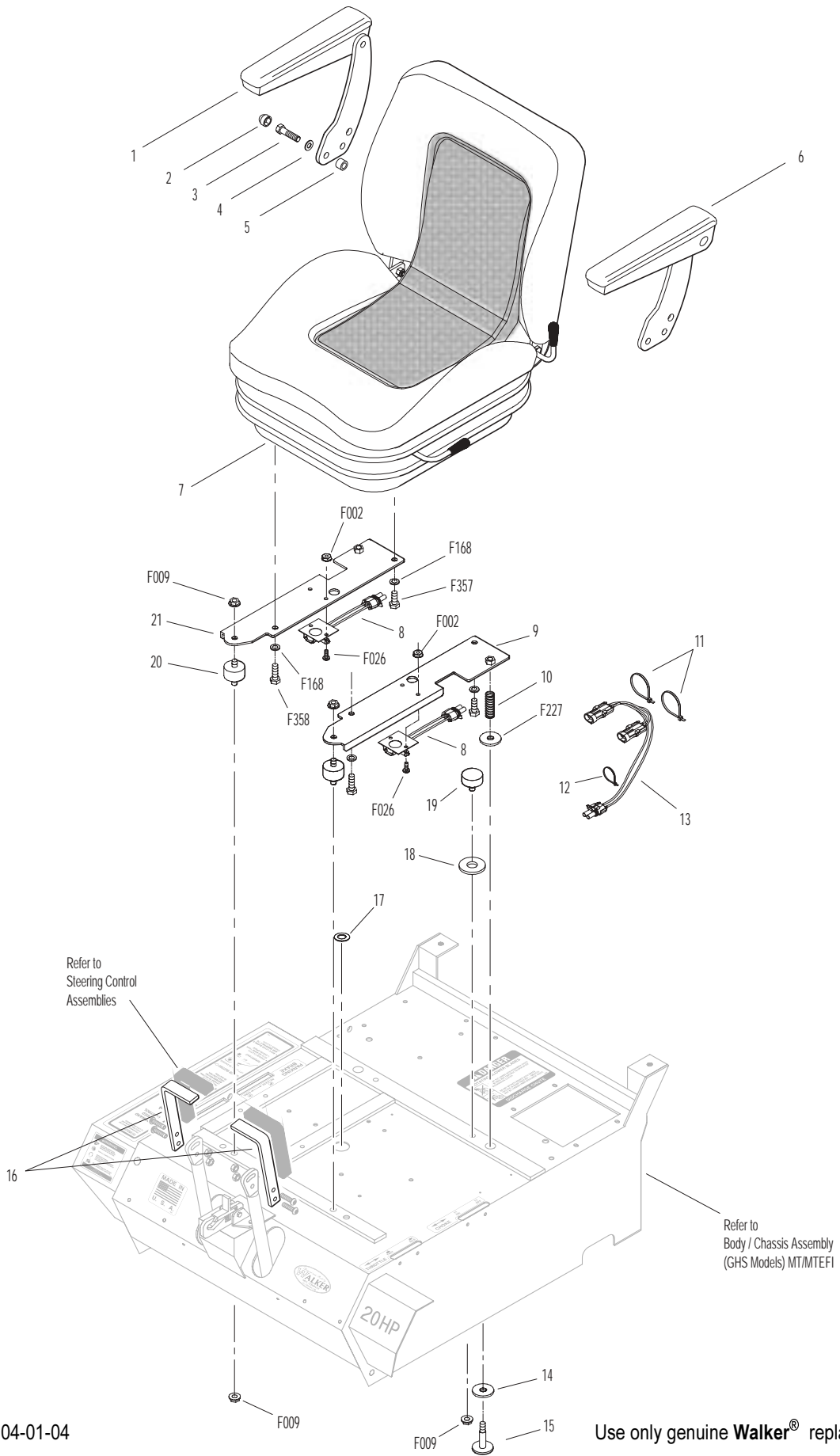

Effective Date 04-01-04

Use only genuine Walker® replacement parts.

LIGHT KIT

ITEM NO.	PART NO.	DESCRIPTION	NO. REQ'D	ITEM NO.	PART NO.	DESCRIPTION	NO. REQ'D
Kit 7989-1 Light Option / Kit Includes Items # 1-8, fasteners listed and instructions. May be ordered as a dealer-installed option. Contact your Walker dealer.				Fasteners			
1	7989-2	Light Assembly (Halogen) (Includes Items # 2 & 4) (Includes Halogen Bulb)	2	F009		5/16-18 Whiz Locknut	2
	7989-6	Halogen Bulb Replacement	*	F052		5/16 Ext. Star Lock Washer	2
2	7989-3	Wire Harness Extension	2	F091		5/16-18 x 5/8 Hex Bolt	2
3	7834-1	Half U-Wire Clip	4	* Service Part Only			
4	5996-4	16-14 GA Bullet Cntr. (M)	3	NOTE: Upon installation of kit, Item # 8 replaces P/N 5989-4 (Dome Plug, 3/8) and Item # F091 replaces P/N 5989-3 (Dome Plug, 5/16). Dome Plugs are not shown here. Refer to BODY / CHASSIS ASSEMBLY (GHS MODELS) MT/MTEFI , Page 4.			
5	5996-5	16-14 GA Bullet Cntr. (F)	2	NOTE: Refer to ELECTRICAL CONNECTORS , Page 58 for identification of all Electrical Wiring Service Parts.			
6	7993	Mount Bracket, Lights	1				
7	7995-3	Power Lead Wire Assembly (Includes Items # 4, 5, 8, 10 & 11)	1				
8	5977-1	Grommet (1/8 x 3/8)	2				
9	5975-5	Wire Clip, Self-Mount	3				
10	5975-1	Cable Tie (18# x 3-3/4")	1				
11	5996	1/4 x 16-14 GA QDF Terminal	1				

LIGHT KIT

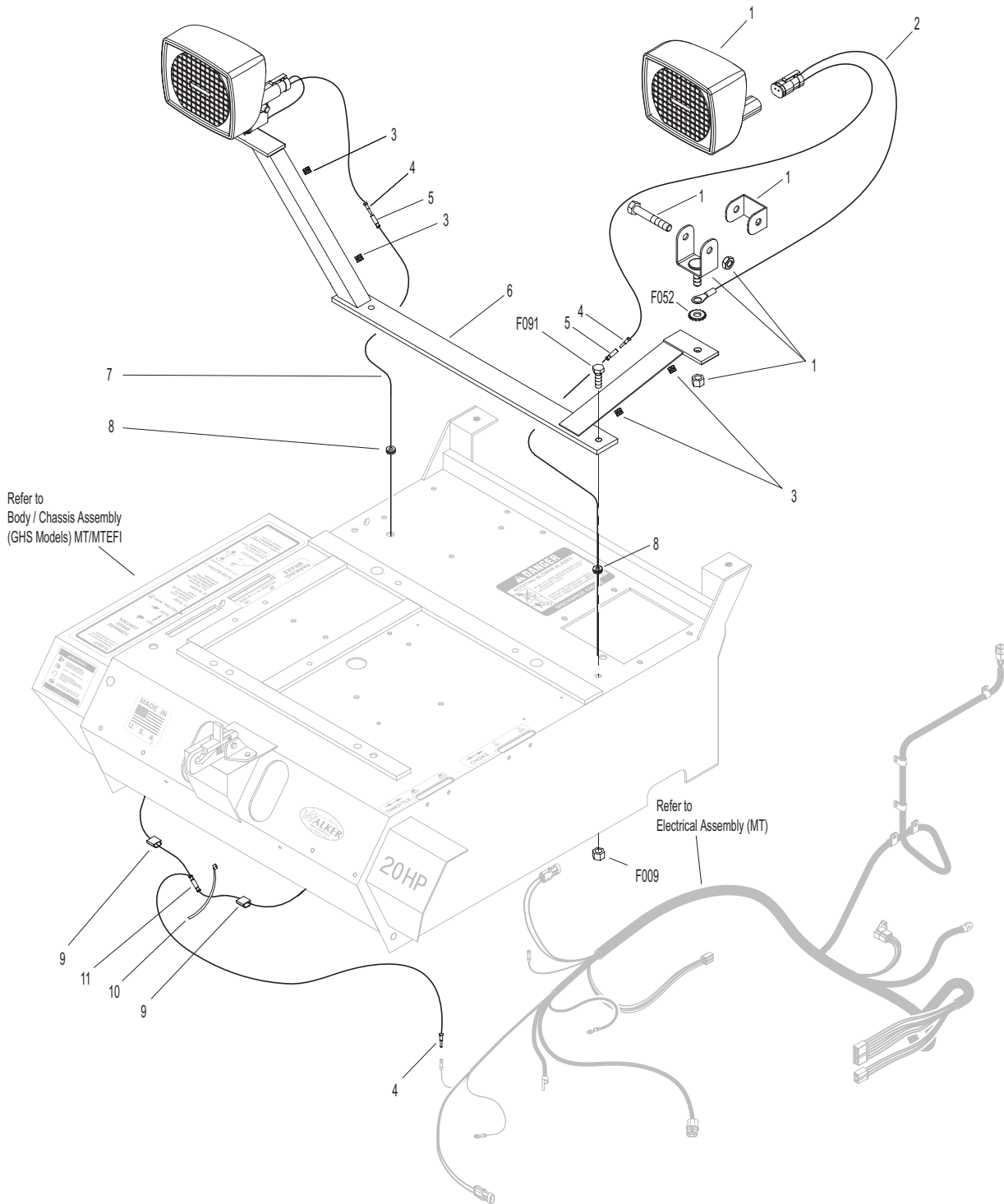

BLOWER LOCKOUT KIT / CASE-HARDENED BLOWER

ITEM NO.	PART NO.	DESCRIPTION	NO. REQ'D
----------	----------	-------------	-----------

Kit 6541 Blower Lockout Kit
Includes Items # 1-7, fasteners and instructions. May be ordered as a kit for dealer installation. Contact your Walker dealer.

1	7854	Plastic Tip, Red	*
2	6541-2	Blower Lockout Rod (Includes Item #1)	1
3	6541-1	Blower Lockout Latch	1
4	5280	Clevis (1/4)	1
5	5281-5	Clevis Pin (1/4 x 0.80)	1
6	6541-3	Blower Lockout Pivot Arm	1
7	6541-4	Blower Lockout Belt Guide	1

ITEM NO.	PART NO.	DESCRIPTION	NO. REQ'D
----------	----------	-------------	-----------

Kit 6542-15 Case Hardened Blower Option
Includes Items # 8-13, fasteners and instructions. May be ordered as a kit for dealer installation. Contact your Walker dealer.

8	5268	Bearing W/Collar (3/4)	2
9	6543-15	Case Hardened Blower Housing	1
10	6545-15	Case Hardened Blower Wheel	1
11	6525-2	Faceplate (10" Blower)	1
12	6526	Intake Tube (6-1/2 x 2-1/2)	1
13	6542-50	Decal, "H" (5/8)	1

Fasteners

F003	1/4-28 Hex Nut	1
F004	1/4-20 Keps Nut	7
F032	1/4-20 x 3/4 Hex Bolt	1
F074	1/4-20 x 3/8 Set Screw	2
F091	5/16-18 x 5/8 Hex Bolt	1
F186	5/64 x 1/2 Cotter Pin	1
F325	1/4-20 x 3 Hex Bolt	1

* Service Part Only

BLOWER LOCKOUT KIT / CASE-HARDENED BLOWER

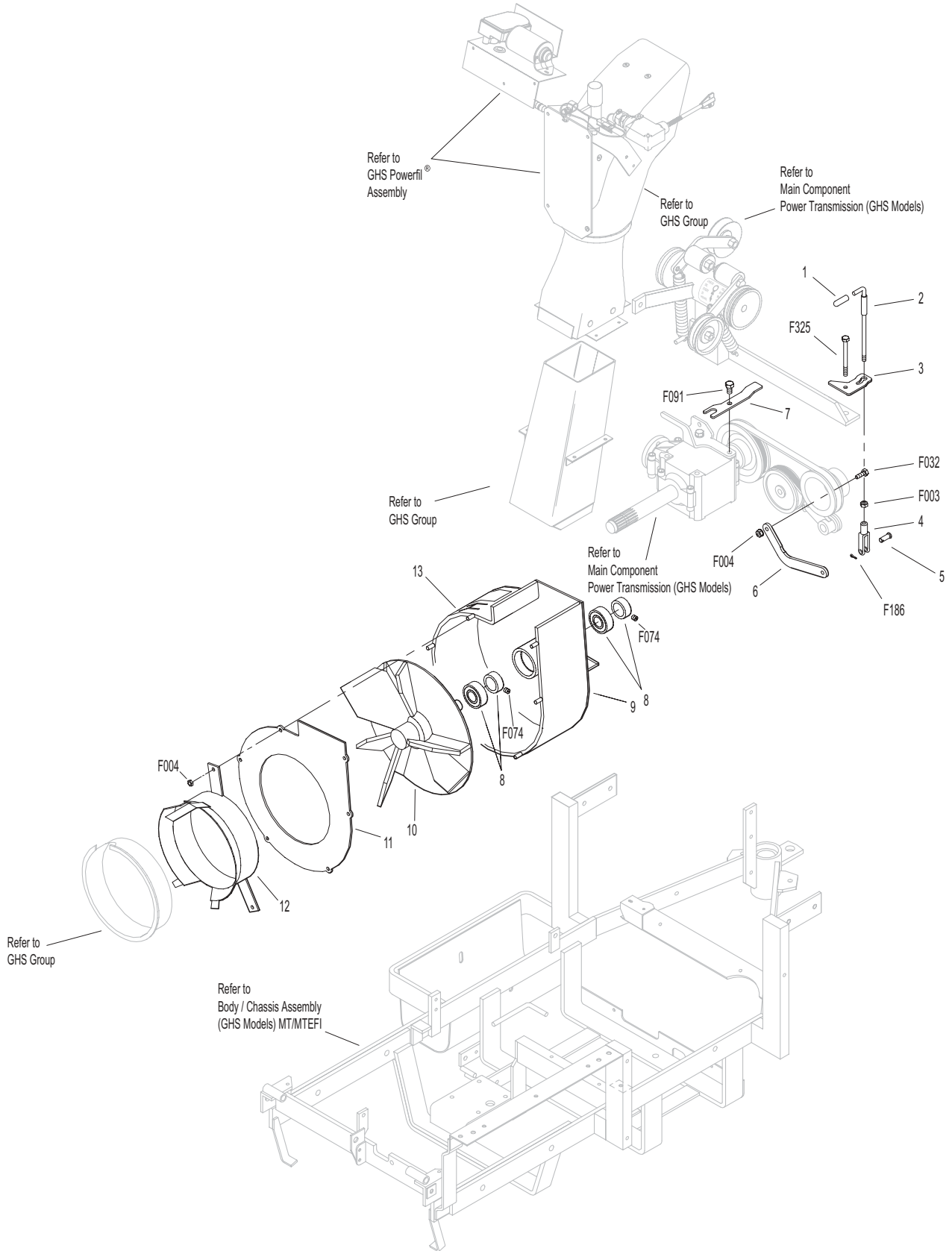

COLD START KIT / SPEED UP KIT

ITEM NO.	PART NO.	DESCRIPTION	NO. REQ'D
----------	----------	-------------	-----------

Kit 8638 Cold Start Option / Kit

Includes Items # 1-3, fasteners F004, F029, and instructions.

1	5830	Grease Fitting	1
2	7406-1	Handle Grip, Red	1
3	8638-1	Idler Release (Includes Items # 1 & 2)	1

Kit 8247 Speed-Up Option / Kit

Includes Items # 4-5 and instructions.

4	5224	Extension Spring (1 x 4)	1
5	7240-1	Jackshaft Drive Pulley (3-1/2/3V) (Includes Items # F067 & F171)	1

Both kits may be ordered as a dealer-installed option. Contact your Walker dealer.

ITEM NO.	PART NO.	DESCRIPTION	NO. REQ'D
----------	----------	-------------	-----------

Fasteners

F004	1/4-20 Keps Nut	2
F029	1/4-20 x 1/2 Hex Bolt	2
F171	5/16-18 x 3/8 Set Screw	*

* Service Part Only

COLD START KIT / SPEED UP KIT

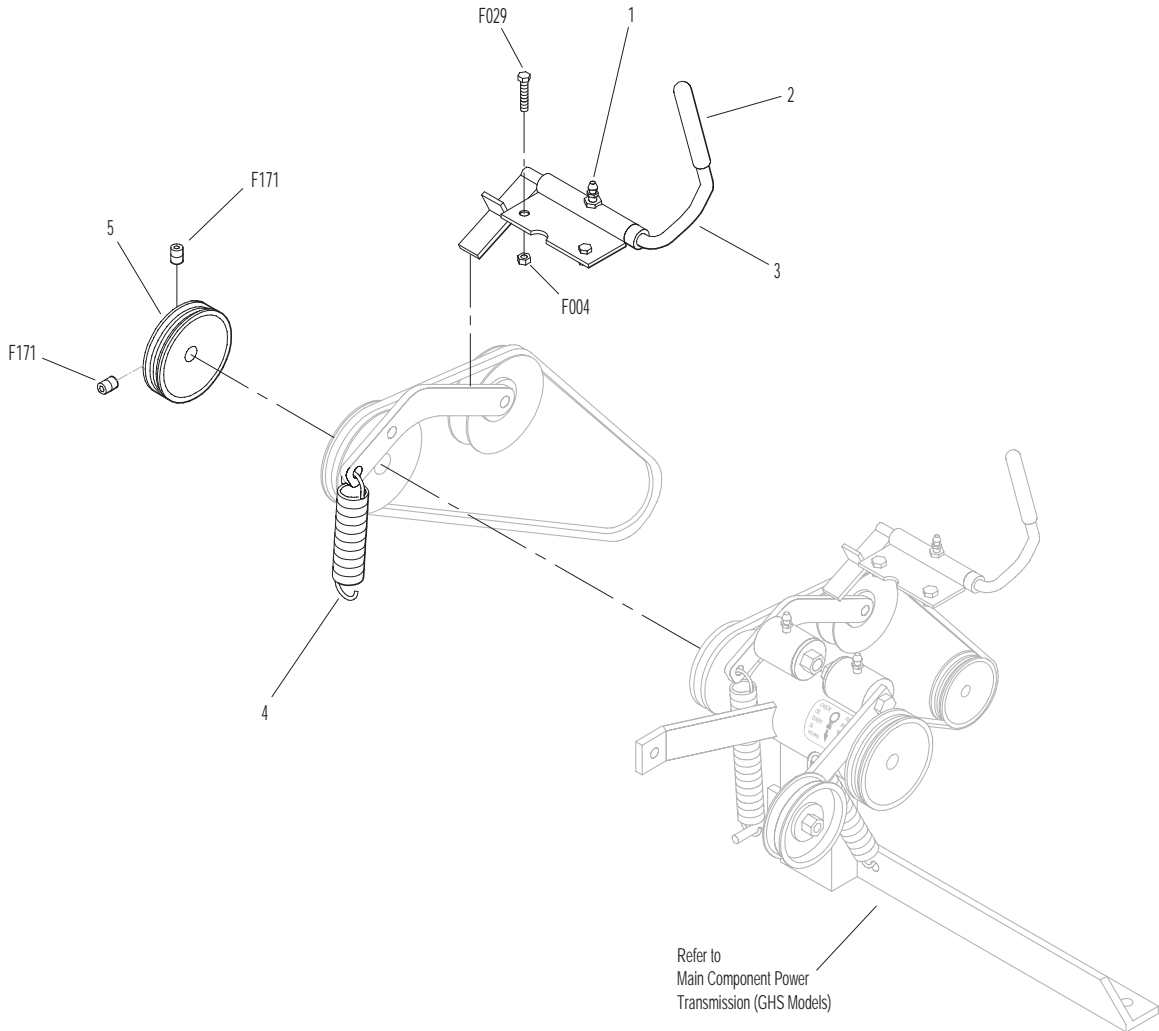

POWER DUMP KIT (7.0 BUSHEL GHS MODELS ONLY)

ITEM NO.	PART NO.	DESCRIPTION	NO. REQ'D
Kit 7620-13 Power Dump Option / Kit (7.0 Models Only)			
Includes Items # 1-33, fasteners listed and instructions. May be ordered as a factory-installed option or as a kit for dealer installation. Contact your Walker dealer. Not to be used with optional Dump Bag Kits.			
1	5522-20	Hinge Backup Plate/RH/PD	1
2	7620-3	Door Pivot Bushing (9/16 x 1/2)	2
3	7612-2	Door Actuator Arm, RH	1
4	7612-1	Door Actuator Arm, LH	1
5	5522-10	Hinge Backup Plate/LH/PD	1
6	7610-5	Extension Spring (1/4 x 2-7/8)	1
7	7523-2	Clevis Pin (1/4 x 5/8)	2
8	7623	Power Dump Cable	2
9	5975-7	Cable Tie (50# x 11")	1
10	7621	Linear Actuator/7.0	1
11	5552	Ball Joint (1/4-28)	2
12	7628-1	Channel Angle, RH	1
13	7620-9	Roller Wheel	2
14	7629	Channel Angle, LH	1
15	5830	Grease Fitting	3
16	7626-0	Actuator Mount	1
17	7624-1	Roller Bearing Bolt	1
18	5832	Cable Clamp (1/2)	1
19	7627	Front Actuator Mount	1
20	7624	Sealed Needle Bearing	1
21	7630-3	Ram Pivot and Spacer	1
22	7625	Fork	1
23	5975-1	Cable Tie (18# x 3-3/4")	1
24	5975-3	Cable Tie (50# x 7")	5
25	7622	Wire Harness	1
26	6623	Toggle Switch	1
27	6623-1	Switch Boot	1
28	7633	Decal, Power Dump	1
29	8105-3	Rear Body Panel, LH (MT/EFI)	1
	8105-35	Rear Body Panel, LH (MTL)	1
30	8105-4	Rear Body Panel, RH (MT/MTL/EFI)	1
31	7620-12	Cable Rod Guide (7.0)	2
32	7620-6	Cable Guide	2
33	7613	Door Actuator	2

ITEM NO.	PART NO.	DESCRIPTION	NO. REQ'D
Fasteners			
	F002	10-24 Keps Nut	6
	F003	1/4-28 Hex Nut	4
	F004	1/4-20 Keps Nut	4
	F009	5/16-18 Whiz Locknut	4
	F012	3/8-16 Keps Nut	2
	F028	10-24 x 3/4 PPHMS	4
	F029	1/4-20 x 1/2 Hex Bolt	4
	F039	3/8-16 x 1-1/4 Hex Bolt	2
	F050	1/4 SAE Washer	2
	F068	1/8 x 1 Cotter Pin	2
	F069	3/32 x 1/2 Cotter Pin	4
	F079	A/A66D Aluminum Pop Rivet	1
	F085	3/16 Rivet Backup Washer	4
	F093	5/16-18 x 1 Hex Bolt	1
	F111	1/8 x 3/4 Cotter Pin	1
	F128	10-24 x 3/8 PTHMS	2
	F134	AN960816L Washer	4
	F266	1/2 x 2-3/4 Shoulder Bolt	1
	F267	1/2 x 1 x 1/16 Washer	4
	F269	10-32 x 5/8 PTHMS	4
	F270	10-32 Cap Nut	4
	F317	3/16 x 1 Split Spring Pin	2

NOTE: Two F009 Fasteners are reused from the Rear Gas Spring Assembly. Refer to **REAR BODY ASSEMBLY (GHS MODELS) MT/MTEFI**, Page 8.

NOTE: Refer to **ELECTRICAL CONNECTORS**, Page 58 for identification of all Electrical Wiring Service Parts.

POWER DUMP KIT (7.0 BUSHEL GHS MODELS ONLY)

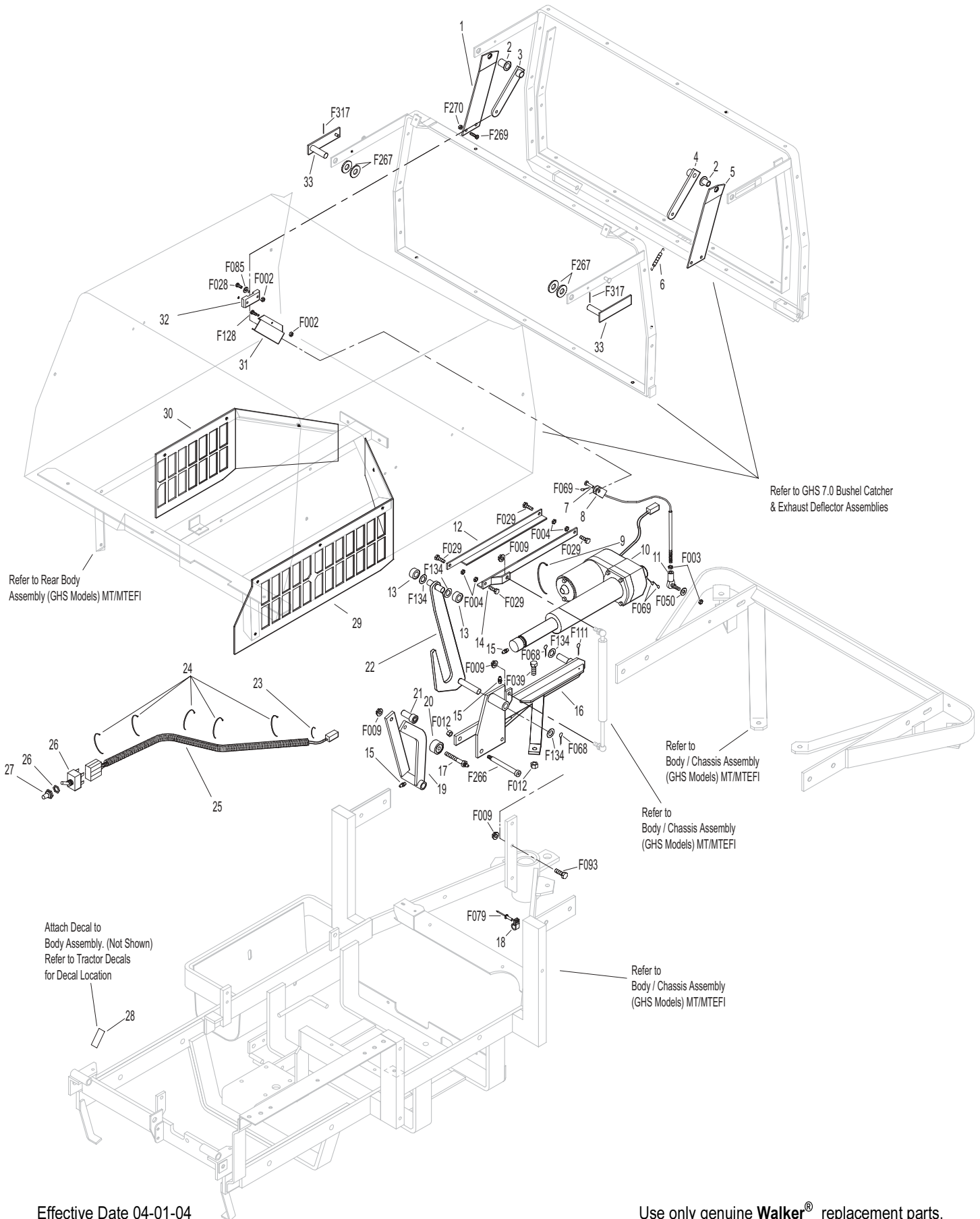

Effective Date 04-01-04

Use only genuine Walker® replacement parts.

POWER DUMP KIT (9.5 BUSHEL GHS MODELS ONLY)

ITEM NO.	PART NO.	DESCRIPTION	NO. REQ'D	ITEM NO.	PART NO.	DESCRIPTION	NO. REQ'D	
Kit 8620-1 Power Dump Option / Kit (9.5 Models Only) Includes Items # 1-33, fasteners listed and instructions. May be ordered as a factory-installed option or as a kit for dealer installation. Contact your Walker dealer.				Fasteners				
1	5522-20	Hinge Backup Plate/RH/PD	1	F002		10-24 Keps Nut	6	
2	7620-3	Door Pivot Bushing (9/16 x 1/2)	2	F003		1/4-28 Hex Nut	4	
3	7612-2	Door Actuator Arm, RH	1	F004		1/4-20 Keps Nut	4	
4	7612-1	Door Actuator Arm, LH	1	F009		5/16-18 Whiz Locknut	3	
5	5522-10	Hinge Backup Plate/LH/PD	1	F012		3/8-16 Keps Nut	2	
6	7610-5	Extension Spring (1/4 x 2-7/8)	1	F028		10-24 x 3/4 PPHMS	2	
7	7523-2	Clevis Pin (1/4 x 5/8)	2	F029		1/4-20 x 1/2 Hex Bolt	4	
8	7623-2	Power Dump Cable	2	F039		3/8-16 x 1-1/4 Hex Bolt	2	
9	5975-7	Cable Tie (50# x 11")	1	F050		1/4 SAE Washer	1	
10	7721	Linear Actuator/9.5	1	F068		1/8 x 1 Cotter Pin	2	
11	5552	Ball Joint (1/4-28)	2	F069		3/32 x 1/2 Cotter Pin	4	
12	8620-5	Guard, 9.5 P.D. Motor	1	F079		A/A66D Aluminum Pop Rivet	1	
13	7628-1	Channel Angle, RH	1	F085		3/16 Rivet Backup Washer	4	
14	7620-9	Roller Wheel	2	F093		5/16-18 x 1 Hex Bolt	2	
15	7629	Channel Angle, LH	1	F111		1/8 x 3/4 Cotter Pin	1	
16	5830	Grease Fitting	3	F134		AN960816L Washer	4	
17	7636-1	Actuator Mount, 9.5	1	F266		1/2 x 2-3/4 Shoulder Bolt	1	
18	7624-1	Roller Bearing Bolt	1	F267		1/2 x 1 x 1/16 Washer	4	
19	5832	Cable Clamp (1/2)	1	F269		10-32 x 5/8 PTHMS	4	
20	7627	Front Actuator Mount	1	F270		10-32 Cap Nut	4	
21	7624	Sealed Needle Bearing	1	F317		3/16 x 1 Split Spring Pin	2	
22	7630-3	Ram Pivot and Spacer	1	F337		1/4 - 20 x 5/8 Self Tap Bolt	2	
23	7625	Fork	1					
24	5975-1	Cable Tie (18# x 3-3/4")	1					
25	5975-3	Cable Tie (50# x 7")	5					
26	7622	Wire Harness	1					
27	6623	Toggle Switch	1					
28	6623-1	Switch Boot	1					
29	7633	Decal, Power Dump	1					
30	8105-3	Rear Body Panel, LH (MT/EFI)	1					
	8105-35	Rear Body Panel, LH (MTL)	1					
31	8105-4	Rear Body Panel, RH (MT/MTL/EFI)	1					
32	7620-6	Cable Guide	2					
33	7613	Door Actuator	2					

NOTE: Two F009 Fasteners are reused from the Rear Gas Spring Assembly. Refer to **REAR BODY ASSEMBLY (GHS MODELS) MT/MTEFI**, Page 8.

NOTE: Refer to **ELECTRICAL CONNECTORS**, Page 58 for identification of all Electrical Wiring Service Parts.

POWER DUMP KIT (9.5 BUSHEL GHS MODELS ONLY)

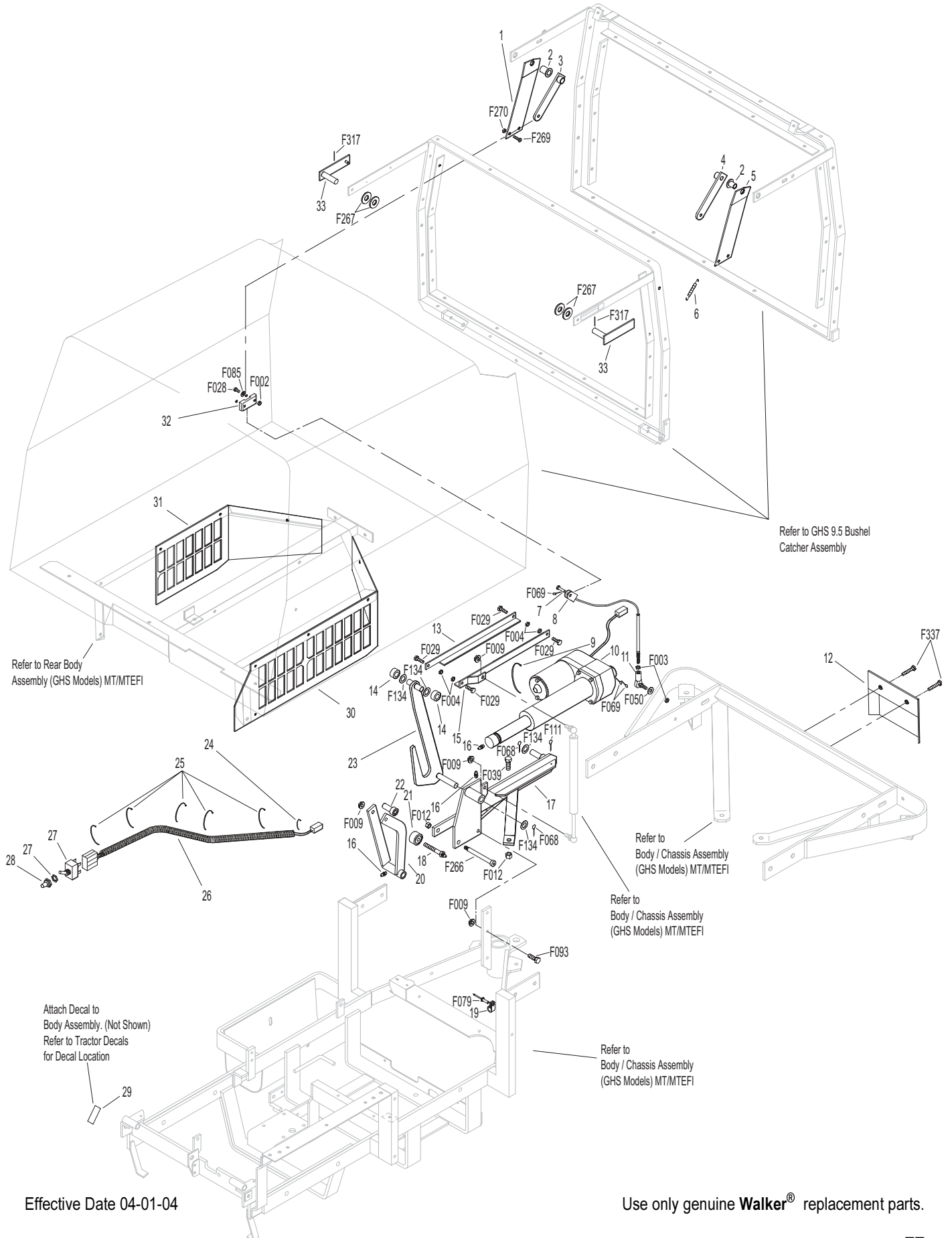

Effective Date 04-01-04

NO CATCH DEFLECTOR KIT / TAIL WEIGHT KIT

ITEM NO.	PART NO.	DESCRIPTION	NO. REQ'D
----------	----------	-------------	-----------

Kit 7500 (7.0 Bushel) No Catch Deflector Option / Kit
Includes Items # 1-5, fasteners and instructions.

Kit 8500 (9.5 Bushel) No Catch Deflector Option / Kit
Includes Items # 1-5, fasteners and instructions.

Both kits may be ordered as a dealer-installed option. Contact your Walker dealer.

1	7500	No-Catch Deflector Kit (7.0)	1
	8500	No-Catch Deflector Kit (9.5)	1
2	8500-5	Side Bracket	2
3	8787-2	Knob (1/4-20) Threaded Insert	1
4	8500-6	Spacer Lug	1
5	8500-8	Decal, No Catch Deflector	1

Kit 7647 Tail Weight Option / Kit

Includes Items # 6, F012, F039 and instructions. May be ordered as a dealer-installed option. Contact your Walker dealer.

6	7647-9	Tail Weight Strap	2
7	7647-5	Tail Weight Plate, 10-lb	*

ITEM NO.	PART NO.	DESCRIPTION	NO. REQ'D
----------	----------	-------------	-----------

Fasteners

F002		10-24 Keps Nut	4
F012		3/8-16 Keps Nut	4
F030		1/4-20 x 1/2 PPH Bolt	1
F039		3/8-16 x 1-1/4 Hex Bolt	4
F128		10-24 x 3/8 PTHMS	4
F175		1/2 Split Lock Washer	2**
F285		1/2-13 x 1-1/2 Hex Bolt	2**
F333		1/4-20 x 3/4 PTHMS	1

* Optional

** Use with optional 10-lb plate.

NO CATCH DEFLECTOR KIT / TAIL WEIGHT KIT

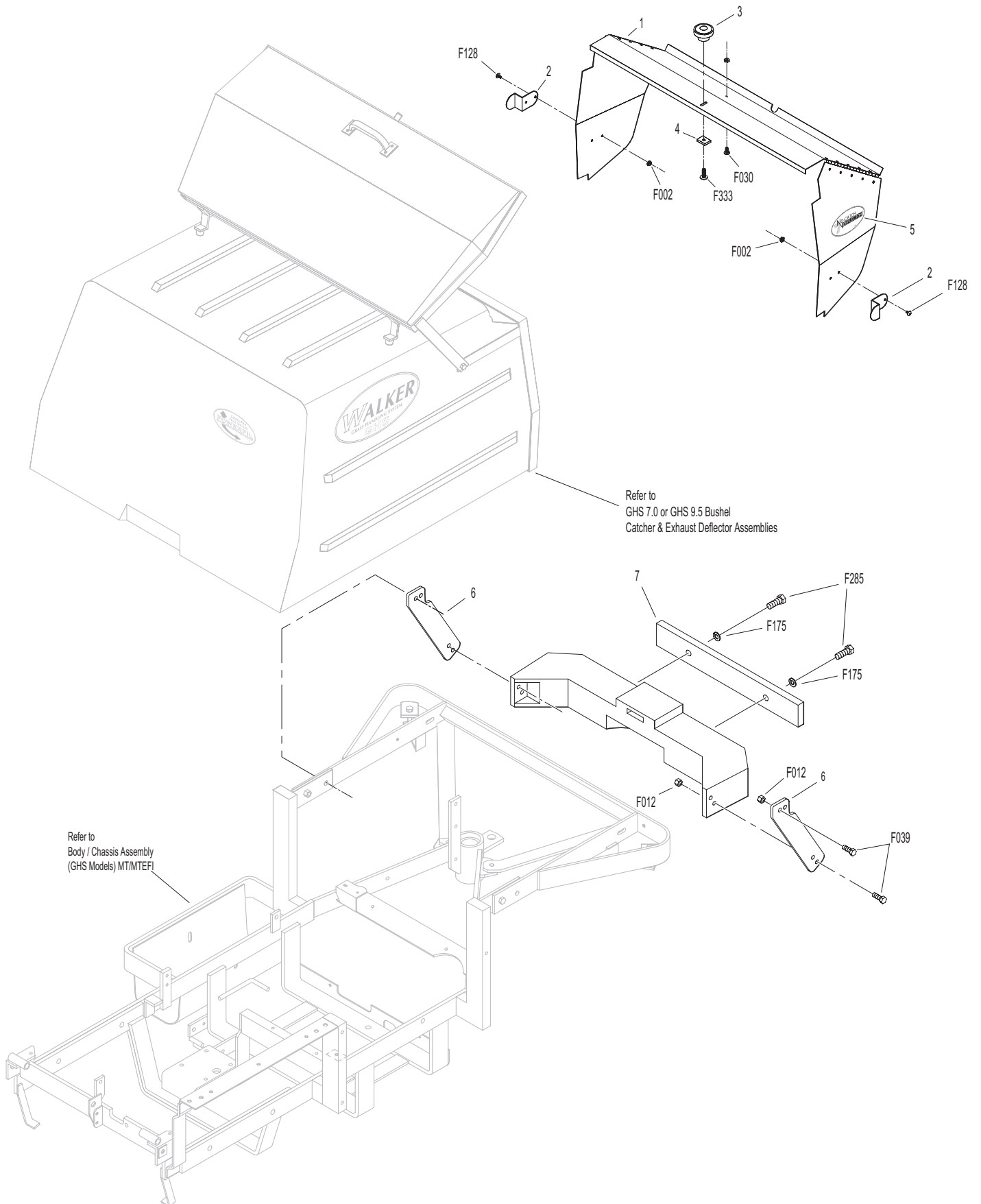

SPREAD TAIL WHEEL AXLE KIT

ITEM NO.	PART NO.	DESCRIPTION	NO. REQ'D	ITEM NO.	PART NO.	DESCRIPTION	NO. REQ'D
Kit 7420-3 Spread Axle Kit/Less Wheels Includes Items # 1-14, fasteners listed & instructions. May be ordered as a dealer-installed option. Contact your Walker dealer.				Fasteners			
1	7420-6	Washer (2-1/2)	1	F012		3/8-16 Keps Nut	2
2	7420-5	Mount, Spread Axle	1	F016		1/2-13 Self-Locking Nut	1
3	8769-8	Dust Cap/Yellow Zinc	2	F038		3/8-16 x 1 Hex Bolt	2
4	8769-6	Bearing Cone (1" ID)	4	F039		3/8-16 x 1-1/4 Hex Bolt	2
5	8769-5	Bearing Cup	4	F140		7/16-14 x 1 Hex Bolt	4
6	7420-4	Fork Mount Tube (Includes Item # 5)	1	F205		5/16-18 x 1/4 Set Screw	2
7	8769-7	Seal	2	F218		7/16 Split Lock Washer	4
8	7420-2	Tail Fork, Spread Axle	2	F278		3/8 Split Lock Washer	2
9	8039	Nut, Tail Wheel Axle	2	F344		3/4-16 Slotted Hex Nut	2
10	8038-1	Spacer, Tail Wheel Axle	2	F347		3/4 SAE Washer	2
11	7038	Tail Wheel Axle (3/4 x 5-9/16)	2	F348		1/8 x 1-1/2 Cotter Pin	2
12	5683	Pivot Bearing	2	F377		1/2-13 x 5 Hex Bolt	1
13	5830	Grease Fitting	3				
14	7420-7	Pivot Shaft (1 x 5-1/4)	1				

NOTE: This kit does not work on Model MTL.

NOTE: If equipped, existing dual tail wheels and tires can be reused with this kit. Order Kit # 7420-20 for two wheels and tires if tractor is equipped with a single wide tail wheel.

SPREAD TAIL WHEEL AXLE KIT

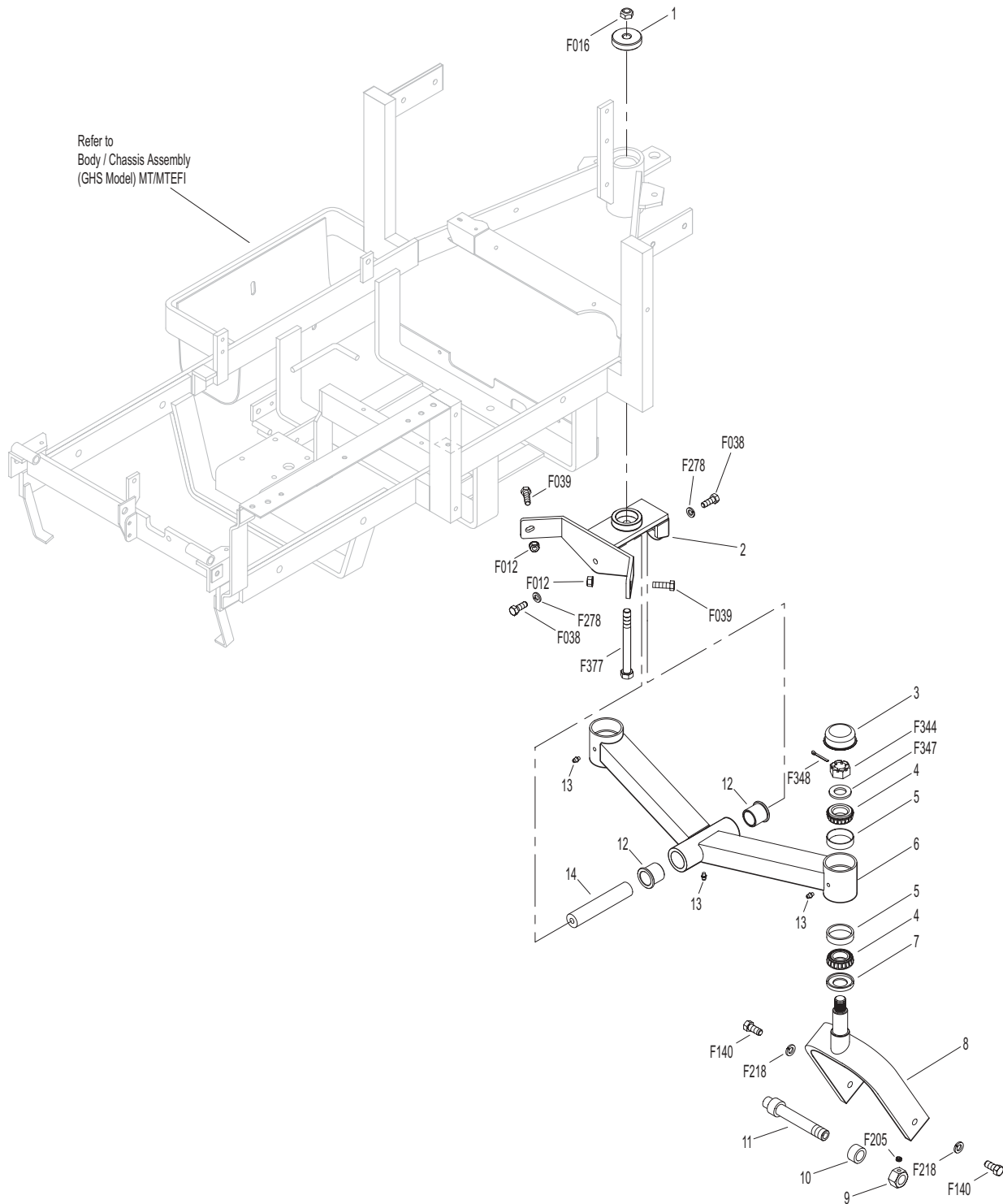

TAIL WHEEL LOCK KIT

ITEM NO.	PART NO.	DESCRIPTION	NO. REQ'D	ITEM NO.	PART NO.	DESCRIPTION	NO. REQ'D	
Kit 8540 Tail Wheel Lock Option / Kit Includes Items # 1-28, fasteners listed & instructions. May be ordered as a dealer-installed option. Contact your Walker dealer.				Fasteners				
1	5995-2	Switch Boot	1	F002		10-24 Keps Nut	4	
2	8547	Switch Mount	1	F003		1/4-28 Hex Nut	1	
3	8555	Decal, Tail Lock Switch	1	F004		1/4-20 Keps Nut	3	
4	5995	Toggle Switch (Off-On)	1	F012		3/8-16 Keps Nut	2	
5	7942-4	Single Connector, Male	2*	F026		10-24 x 1/2 PPHMS	2	
6	5940-4	16-14 GA Spg. Loaded Term., Female	5*	F029		1/4-20 x 1/2 Hex Bolt	2	
7	5977-2	Grommet, Cut (1/8 x 3/8)	1	F038		3/8-16 x 1 Hex Bolt	2	
8	5975-3	Cable Tie (50# x 7")	4	F050		1/4 SAE Washer	2	
9	8550	Wire Harness	1	F134		AN960816L Washer	1	
10	5975-1	Cable Tie (18# x 3-3/4")	3	F179		1/4-20 x 1 Hex Bolt	2	
11	8553	Splice Tap (18-14 GA)	1	F190		#10 Internal Star Lock Washer	1	
12	8543	Solenoid Mount	1	F198		.250 x .625 x .040 Washer, SS	1	
13	5830-3	Grease Fitting (45 Degree)	1	F298		3/8-24 Jam Nut	1	
14	8551	Ground Wire	1	F299		10-24 x 1 PPHMS	2	
15	8546	Solenoid, Control Module	1	F300		1.015 x 1.500 x .031 Washer	1	
16	5996	1/4 16-14 GA QKS Term., Female	5*	F350		1/4-20 LP Nylock	1	
17	8552	Connector Plug & Wire Assy	1	* Service Part Only				
18	8544	Clevis, Wheel Lockout (9/16)	1	NOTE: Refer to ELECTRICAL CONNECTORS , Page 58 for identification of all Electrical Wiring Service Parts.				
19	5551-1	Pivot Bearing	2*					
	8545-1	Pivot Bearing Assembly (Includes Items # 19, 20, F179 & F350)						
20	8544-1	Bearing Spacer (1/4 ID x 9/16)	1*					
21	8542	Tail Wheel Fork, Locking	1					
22	8944	3-Way Locking Connector, Male	1*					
23	8944-1	3-Way Locking Connector, Female	1*					
24	5940-5	16-14 GA Spg. Loaded Term., Male	1*					
25	5996-13	16-14 GA Ring Term., #10	1*					
26	7929	Actuating Solenoid	1					
27	8549	Sleeve, Delrin	1					
28	8541	Plunger Rod	1					
	8554	Solenoid & Mount Assembly (Includes Items # 12-15, 17-20, 26-28, F002, F003, F004, F029, F050, F179, F190, F198, F298, F299 & F350)	*					

TAIL WHEEL LOCK KIT

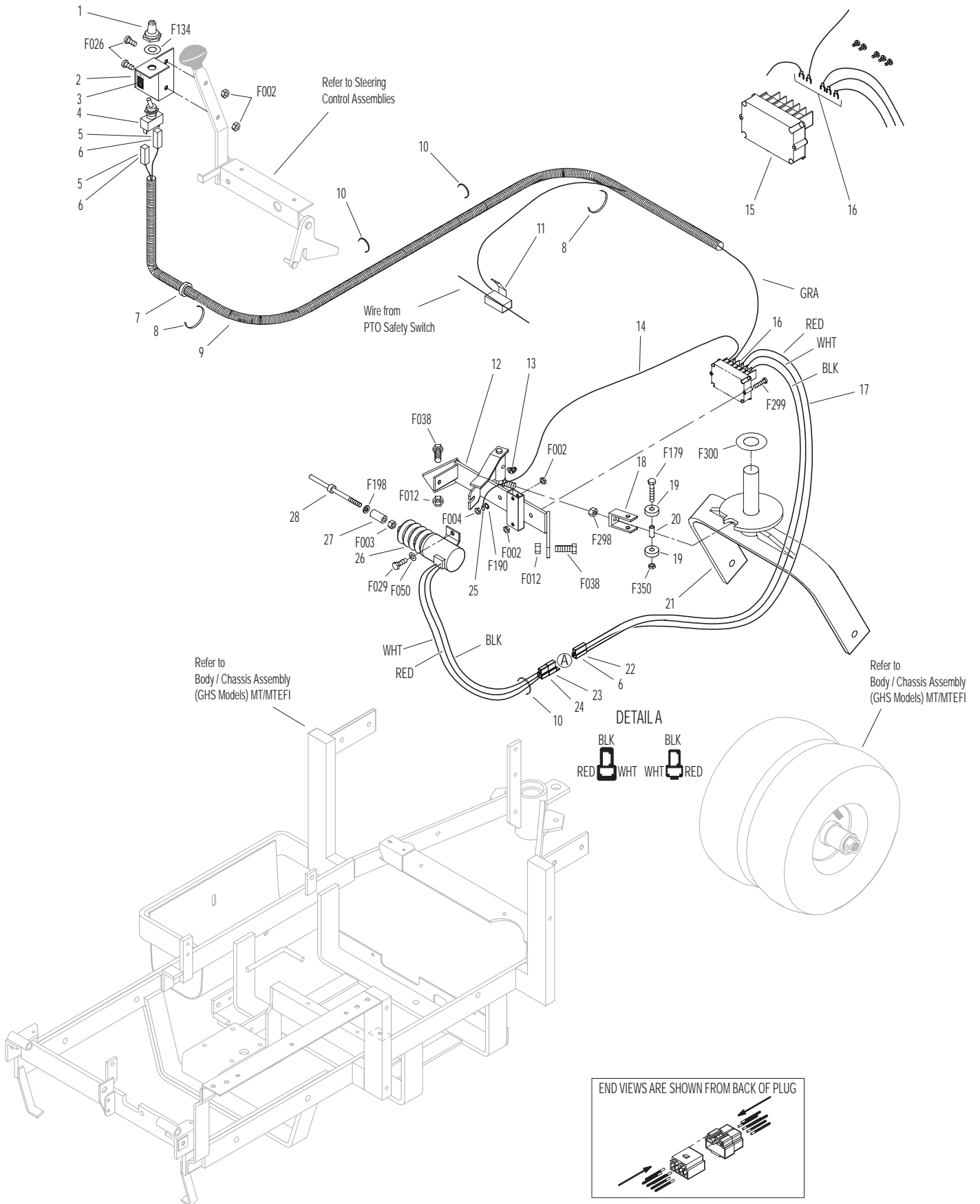

Effective Date 04-01-04

Use only genuine Walker® replacement parts.

WIDE TAIL WHEEL / ALL-TERRAIN TIRE KIT & TIRE CHAIN SET

ITEM NO.	PART NO.	DESCRIPTION	NO. REQ'D
----------	----------	-------------	-----------

Kit 8049 Wide Tail Wheel Option / Kit
Includes Items # 1, 3 and instructions. May be ordered as a dealer-installed option. Contact your Walker dealer.

1	8037-1	Seal, Tail Wheel Axle	2
2	8048	Wide Tail Wheel Axle	1
3	8045	Wide Tail Wheel & Tire (13 x 8.00-6)	1
	8045-1	Wide Tire (13 x 8.00-6)	*
	8047	Wheel & Hub (6 x 7)	*

Kit 8072 All-Terrain Tire Option / Kit
Includes Items # 4, 6 and instructions. May be ordered as a dealer-installed option. Contact your Walker dealer.

4	8071	All-Terrain Wheel & Tire, LH (18 x 11.00-10)	1
5	8070-31	Wheel Spacer Plate (1/2)	2
6	8070	All-Terrain Wheel & Tire, RH (18 x 11.00-10)	1
	8070-1	AT Tire (18 x 11.00-10)	*
	8070-2	AT/LP Wheel (10 x 8.5)	*
	8075-2	AT/LP Tire Tube	*

ITEM NO.	PART NO.	DESCRIPTION	NO. REQ'D
----------	----------	-------------	-----------

Kit LP8075 Low Profile Tire Option / Kit
Includes Item # 7 and instructions. May be ordered as a factory-installed option, or as a kit for dealer installation. Contact your Walker dealer.

7	8075	LP Wheel & Tire (18 x 10.5-10)	2
	8075-1	LP Tire (18 x 10.5-10)	*
	8070-2	AT/LP Wheel	*
	8075-2	AT/LP Tire Tube	*

Optional Tire Chain Set

8	5675-3	Tire Chain Set (18 x 9.50-8)	1
---	--------	------------------------------	---

* Service Part Only

WIDE TAIL WHEEL / ALL-TERRAIN TIRE KIT & TIRE CHAIN SET

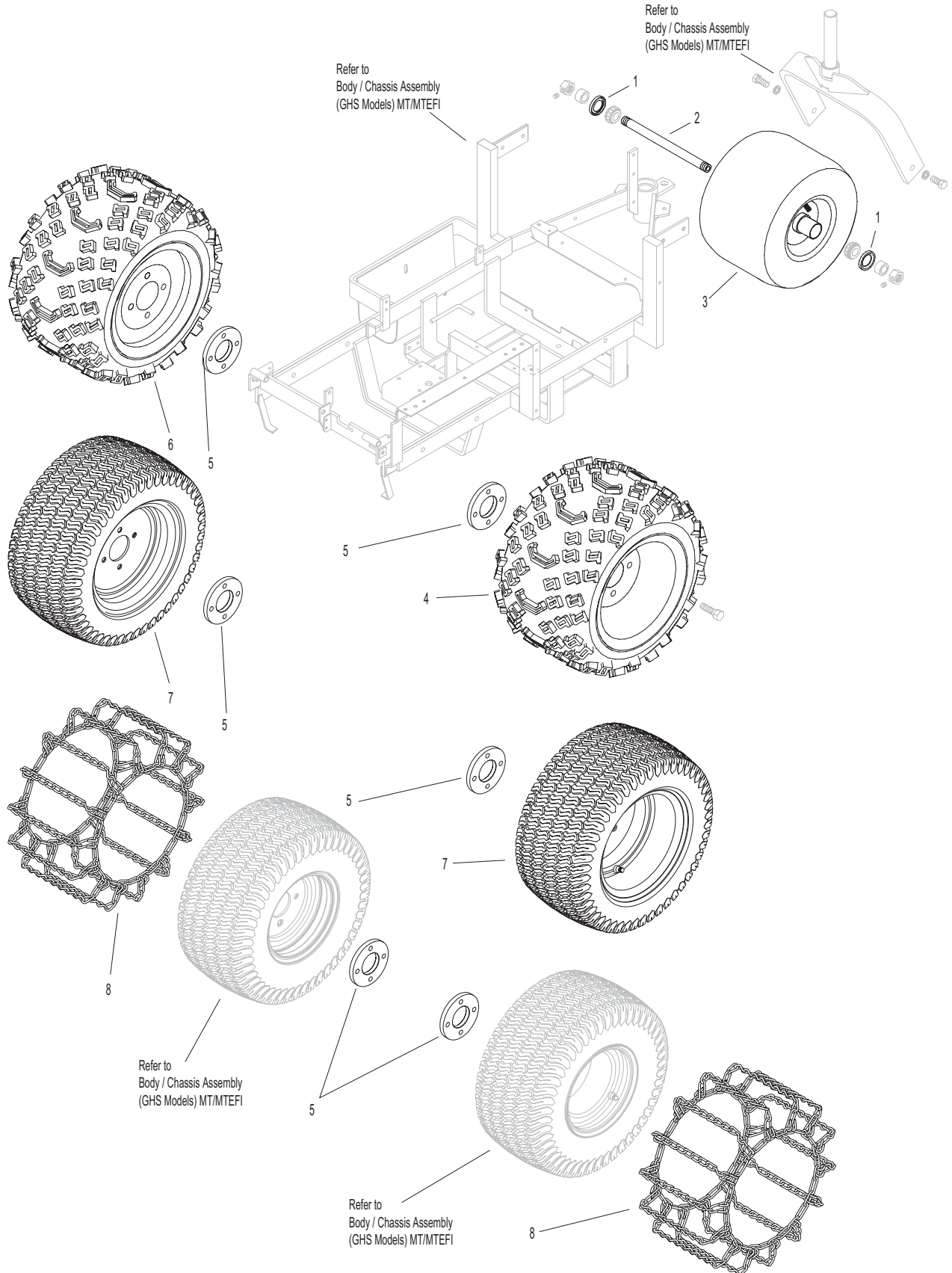

LUBRICATION POINTS

ITEM NO.	LOCATION	LUBRICATION TYPE	NO. PLACES	ITEM NO.	LOCATION	LUBRICATION TYPE	NO. PLACES
Lubrication Points				25	Brake Actuator Rod and Brake Band Pivot Pins (Clevis)	Oil	3
1	Deck Caster Wheel Fork Pivot	Grease	2	26	Brake Actuator Pivot	Grease	1
2	Deck Caster Wheel Bearing	Grease	2	27	Catcher Hinge Point	Oil	2
3	Tee Gearbox, Deck	Oil*	1	28	Rear Wheel Bearings	Grease	2
4	Blade Drive Gearbox	Oil*	2	29	Engine Oil	Oil***	1
5	Universal Joint Shaft Assembly	Grease**	1	30	Choke Control Cable Ends (Models MT and MTL only)	Oil	2
6	Pivot Assembly, Tilt-Up Deck	Grease	4	31	Belt Tightener Pivot, Blower Drive (GHS Model Only)	Grease	1
7	Deck Support Arm Socket	Grease	2	32	Belt Tightener Pivot, Ground Drive	Grease	1
8	Body Hinge Point	Oil	2	33	PTO Gearbox Dipstick	Oil***	1
9	FSC Actuator Rod Pivot Pins	Oil	2	34	Hydrostatic Drive	Oil***	2
10	FSC Lever Pivot	Grease	1	35	Choke Control Pivot (Models MT and MTL only)	Oil	1
11	FSC Lever Fork (Grease Slide Area)	Grease	1	36	Throttle Control Pivot	Oil	1
12	(FSC) Friction Body Pivot	Grease	1				
13	Steering Lever Pivot	Grease	4				
14	Deck Support Arm Pivot	Grease	2				
15	Deck-to-PTO Coupling (Grease Slide Area)	Grease	1				
16	Universal Joint Tube Assembly	Grease**	1				
17	Universal Joint Quick Connect Spline (Grease Slide Area)	Grease	1				
18	Parking Brake Lever	Grease	1				
19	Gear Axle	Oil***	2				
20	Belt Tightener Pivot, Jackshaft Drive	Grease	1				
21	Throttle Control Cable Ends	Oil	2				
22	Clutch Actuator Push Rod	Grease	2				
23	PTO Clutch Lever Pivot	Grease	1				
24	Belt Tightener Pivot, PTO Clutch	Grease	1				

* Gearboxes are permanently lubricated and sealed requiring no scheduled lubrication. Oil level should be checked only when an oil leak is noted.

** Grease every eight (8) hours.

*** Refer to MT **Owner's Manual** for procedure for checking and changing oil in Engine Crankcase, Hydrostatic Transmissions and Gear Axles.

NOTE: See Model MT **Owner's Manual** (P/N 8000-6) for proper lubrication intervals.

NOTE: DGHS42 Tilt-Up Deck is shown for reference. For other Deck Lubrication Points, Refer to Deck and Carrier Frame **Illustrated Parts Manual**.

LUBRICATION POINTS

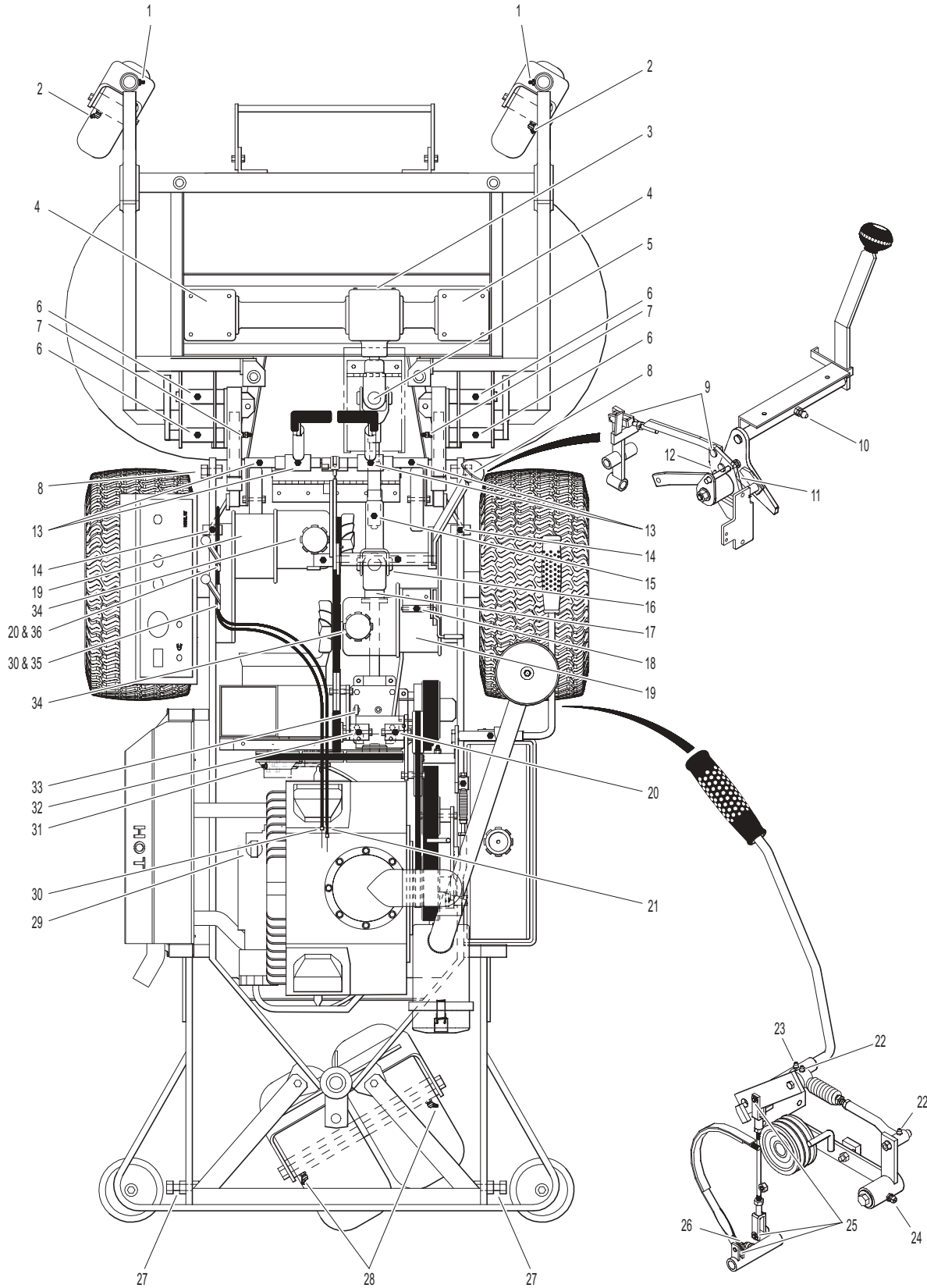

WIRING SCHEMATIC (MT)

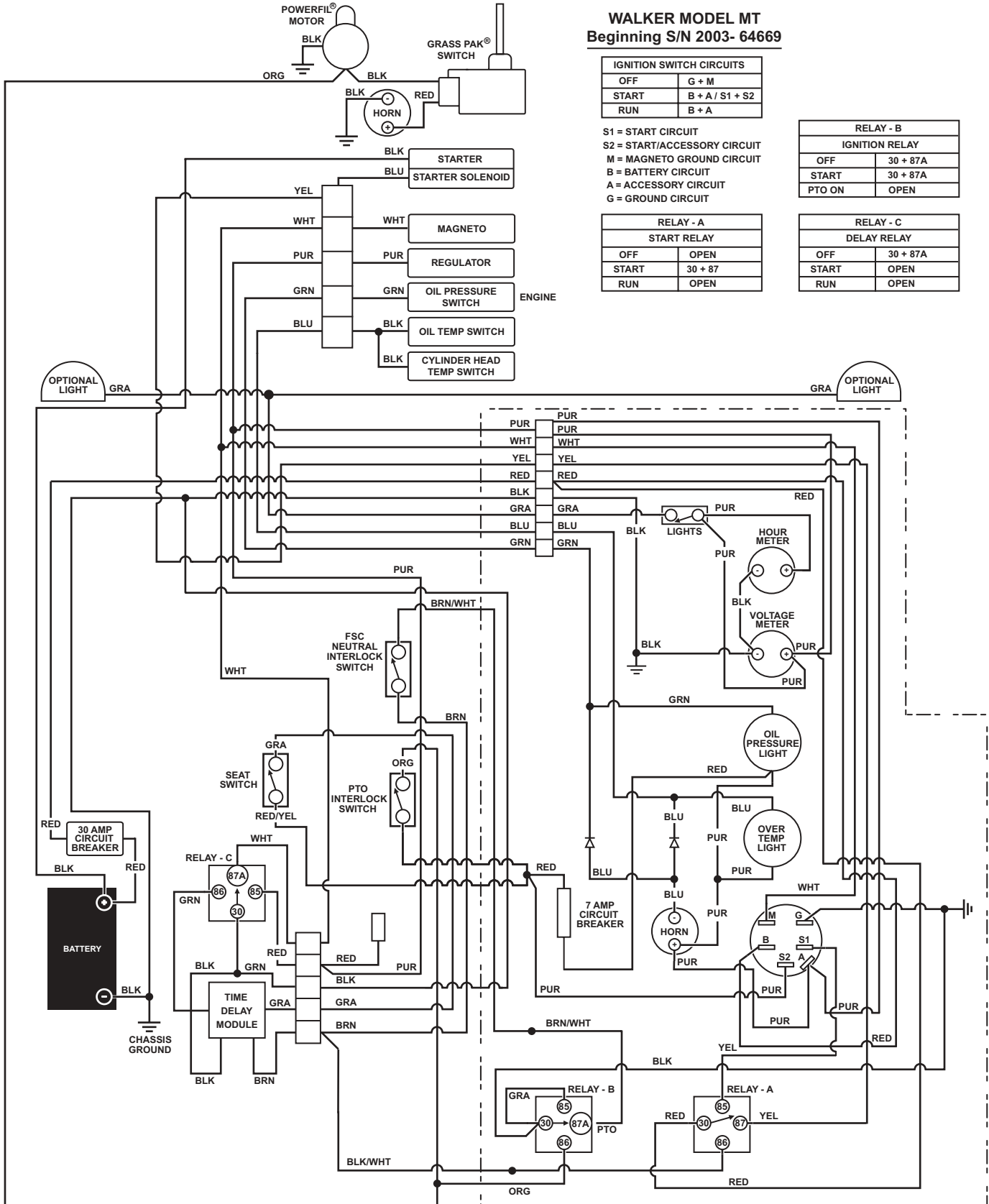

Use only genuine Walker® replacement parts.

Effective Date 04-01-04

WIRING SCHEMATIC (MTL)

WALKER MODEL MTL
Beginning S/N 2003-64669

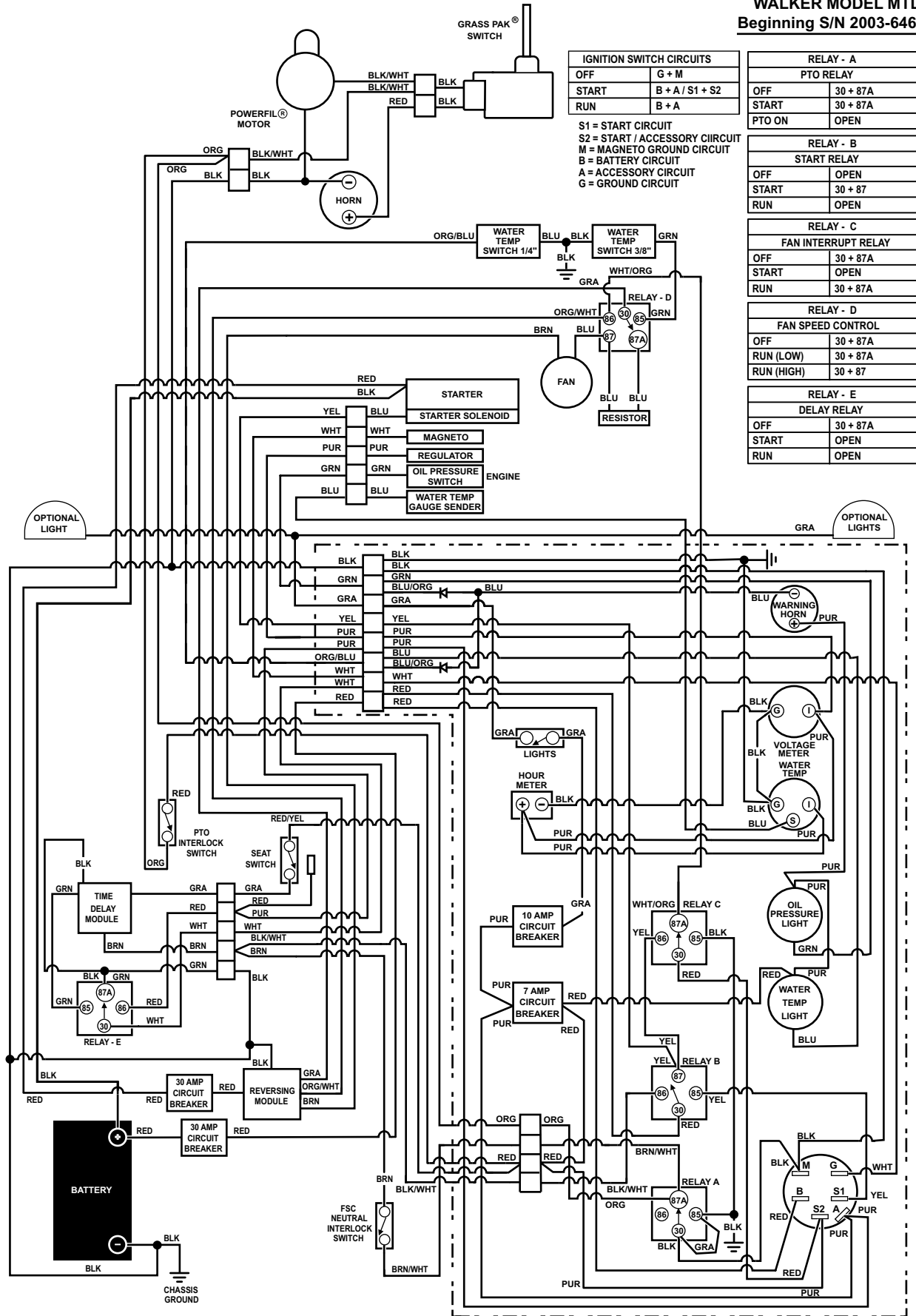

Effective Date 04-01-04

Use only genuine Walker® replacement parts.

WIRING SCHEMATIC (MTEFI)

WALKER MODEL MT-EFI Beginning S/N 2003-64669

IGNITION SWITCH CIRCUITS	
OFF	G + M
START	B + A / S1 + S2
RUN	B + A

S1 = START CIRCUIT
 S2 = START / ACCESSORY CIRCUIT
 M = MAGNETO GROUND CIRCUIT
 B = BATTERY CIRCUIT
 A = ACCESSORY CIRCUIT
 G = GROUND CIRCUIT
 J1 = #1 FUEL INJECTOR
 J2 = #2 FUEL INJECTOR
 J3 = THROTTLE POSITION SENSOR
 J4 = OIL TEMP SENSOR
 J5 = OXYGEN SENSOR
 J6 = REGULATOR / RECTIFIER
 J8 = ENGINE GROUND
 J10 = #1 IGNITION COIL
 J11 = #2 IGNITION COIL
 J12 = #1 IGNITION COIL
 J13 = #2 IGNITION COIL
 J14 = IGNITION COIL GROUND
 J20 = SPEED PICK-UP SENSOR

RELAY - A IGNITION / FUEL RELAY	
OFF	OPEN
START	OPEN
PTO ON	30 + 87

RELAY - B DELAY RELAY	
OFF	30 + 87A
START	OPEN
RUN	OPEN

RELAY - C START / TIME DELAY RELAY	
OFF	30 + 87A
START	30 + 87A
RUN	OPEN

RELAY - D START / SOLENOID RELAY	
OFF	OPEN
RUN (LOW)	OPEN
RUN (HIGH)	30 + 87

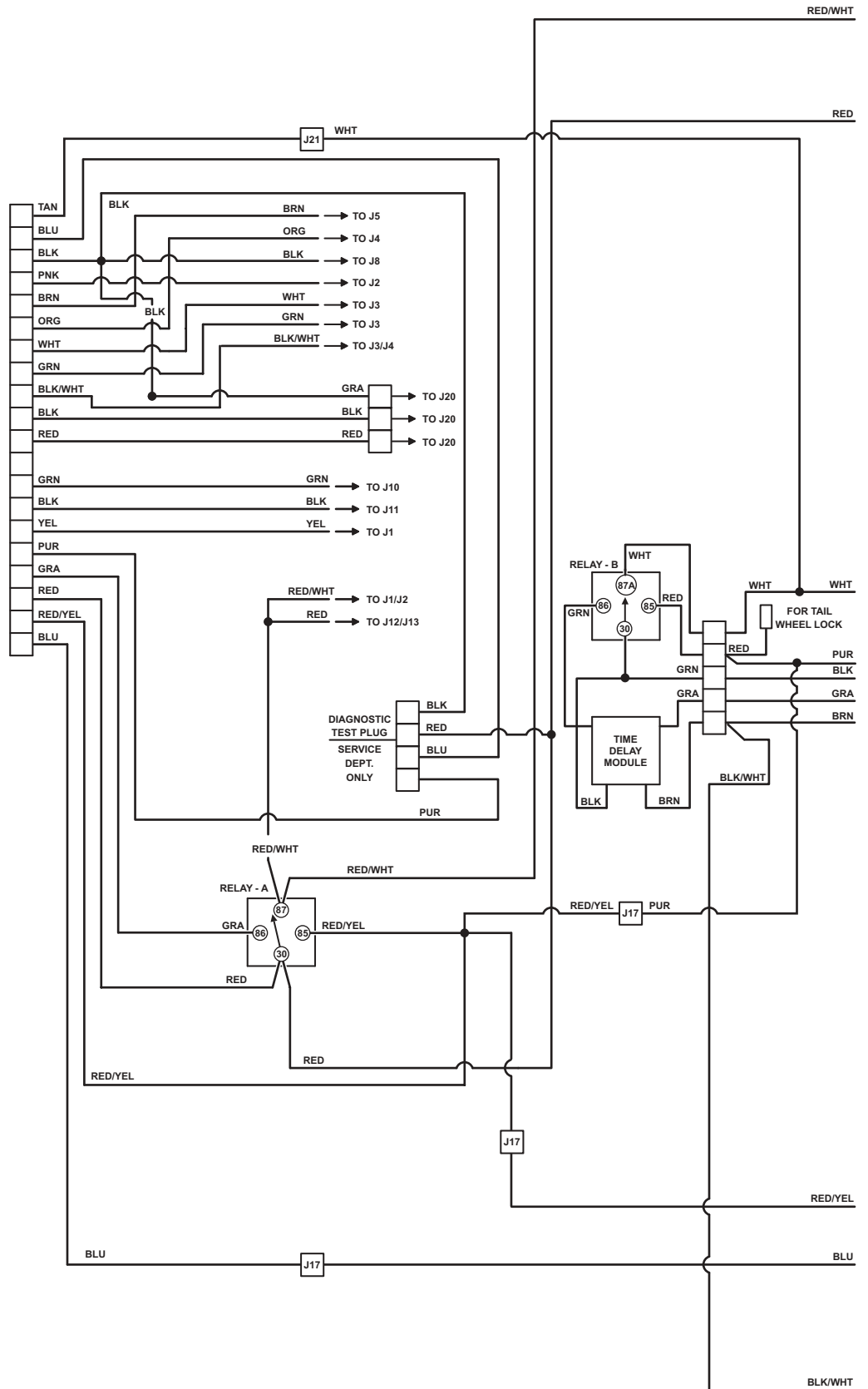

WIRING SCHEMATIC (MTEFI)

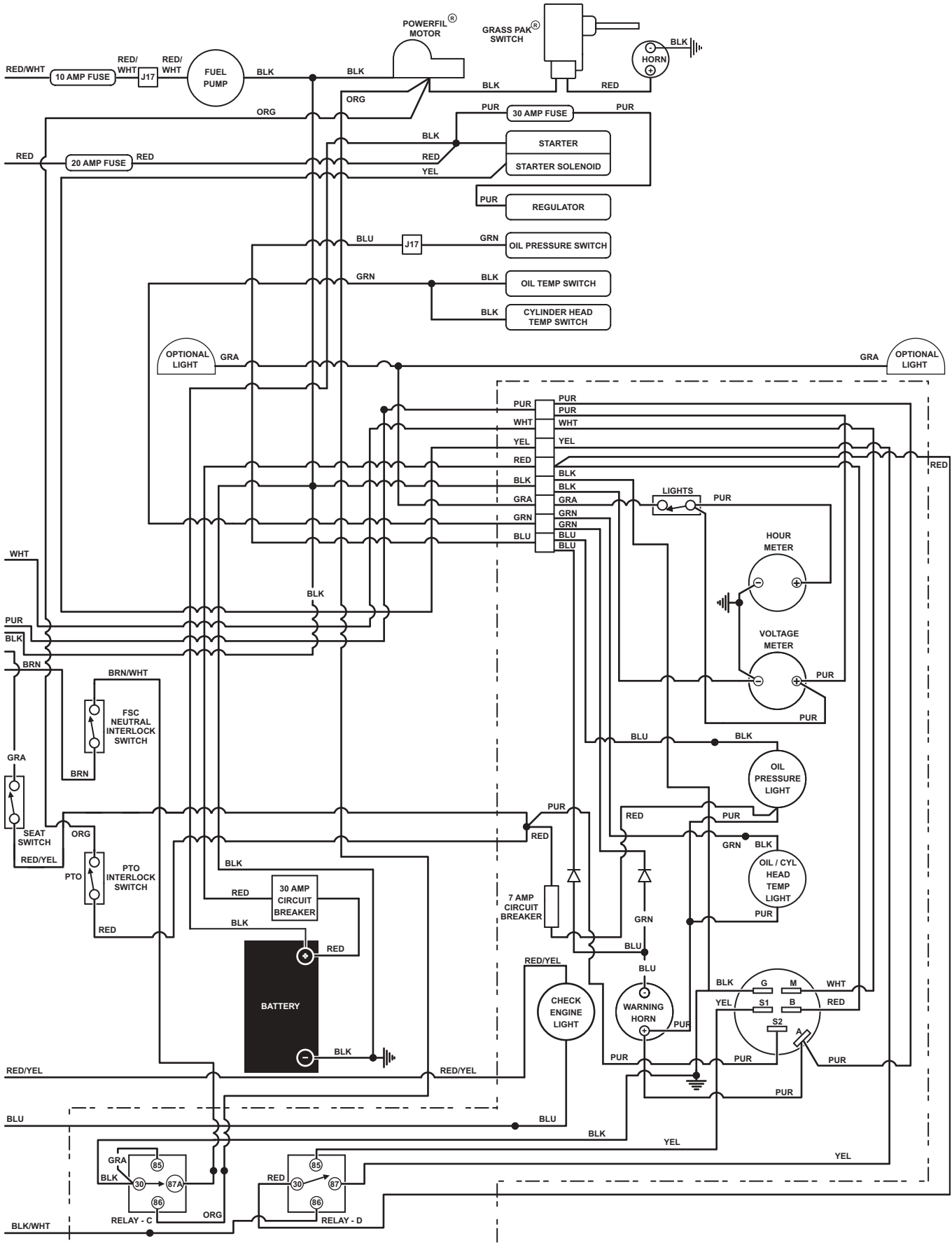

Effective Date 04-01-04

Use only genuine **Walker**® replacement parts.

OPERATOR'S NOTES

LIMITED WARRANTY FOR WALKER COMMERCIAL RIDER MOWER

1. WHAT THIS WARRANTY COVERS, AND FOR HOW LONG:

Walker Manufacturing company will, at its option, repair or replace, without charge, any part covered by this warranty which is found to be defective in material and/or workmanship within one (1) year* after date of sale to the original retail purchaser unless the product is used for rental purposes, in which case this warranty is limited to ninety (90) days. At Walker's request, customer will make the defective part available for inspection by Walker and/or return the defective part to Walker, transportation charges prepaid. All parts and components of the Walker Mower are covered by this warranty **except** the following components which are warranted separately by their respective manufacturers:

Kohler Engine
Kubota Engine
Kawasaki Engine
Eaton Hydraulic Transmission
Peerless Gearboxes
Battery
Tires

The available warranties covering these items are furnished with each mower. Walker does not assume any warranty obligation, liability or modification for these items, which are covered exclusively by the stated warranty of the respective manufacturers noted above.

* An extended three (3) year warranty is offered on the Walker P/N 6200-9 Gear Axle Assembly.

2. WHAT THIS WARRANTY DOES NOT COVER:

- A. This warranty does not cover defects caused by depreciation or damage caused by normal wear, accidents, improper maintenance, improper use or abuse of the product, alterations, or failure to follow the instructions contained in the Owner's Manual for operation and maintenance.
- B. The customer shall pay any charges for making service calls and/or for transporting the mower to and from the place where the inspection and/or warranty work is performed.

3. HOW TO OBTAIN SERVICE UNDER THIS WARRANTY:

Warranty service can be arranged by contacting the dealer where you purchased the mower or by contacting Walker Manufacturing Company, 5925 East Harmony Road, Ft. Collins, CO 80528. Proof of the date of purchase may be required to verify warranty coverage.

4. WARRANTY LIMITATION:

- A. **THERE IS NO OTHER EXPRESS WARRANTY. ANY WARRANTY THAT MAY BE IMPLIED FROM THIS PURCHASE INCLUDING MERCHANTABILITY AND FITNESS FOR A PARTICULAR PURPOSE IS HEREBY LIMITED TO THE DURATION OF THIS WARRANTY AND TO THE EXTENT PERMITTED BY LAW ANY AND ALL IMPLIED WARRANTIES ARE EXCLUDED.** Some states do not allow limitations on how long an implied warranty lasts, so the above limitations may not apply to you.
- B. **WALKER WILL NOT BE LIABLE FOR ANY INCIDENTAL, CONSEQUENTIAL, OR SPECIAL DAMAGES AND/OR EXPENSES IN CONNECTION WITH THE PURCHASE OR USE OF THE MOWER.** Some states do not allow the exclusion or limitation of incidental or consequential damages, so the above limitation(s) or exclusion(s) may not apply to you.
- C. Only the warranty expressed in this limited warranty shall apply and no dealer, distributor, or individual is authorized to amend, modify, or extend this warranty in any way. Accordingly, additional statements such as dealer advertising or presentations, whether oral or written, do not constitute warranties by Walker, and should not be relied upon.
- D. This warranty gives you specific legal rights, and you may also have other rights which vary from state to state.

WALKER MOWERS™

WALKER MFG. CO. • 5925 E. HARMONY ROAD, FORT COLLINS, CO 80528 • (970) 221-5614
FORM NO. 040104 PRINTED IN USA www.walkermowers.com ©2004 WALKER MFG. CO