

WALKER

Illustrated Parts Manual

C19



Beginning S/N: 125718
Effective Date: 11.25.13
P/N 6000-17

KEY TO ABBREVIATIONS USED IN THIS MANUAL

<i>Abbreviation</i>	<i>What it Represents</i>
° (Dimension)	Degrees (Angle)
" (Dimension)	inches
(-)	Negative (Polarity)
(+)	Positive (Polarity)
AT	All-Terrain
CCW	Counter-clockwise
Conn	Connector
CW	Clockwise
D	Diameter
DC	Deck, Collection (number refers to size in inches)
DM	Deck, Mulching (number refers to size in inches)
DR	Deck, Rear Discharge (number refers to size in inches)
DS	Deck, Side Discharge (number refers to size in inches)
DU	Garlock (Bearing)
ESNA (Fastener)	Nylon Insert Locknut
FSC	Forward Speed Control
GA	Gauge
gal	gallon
GHS	Grass Handling System
GR (Fastener)	Grade
HD	Heavy Duty
HP	Horse Power
ID	Identification or Inside Diameter
L	Length
LH	Left Hand (orientated with operator on seat)
LP	Low Profile
mm (Dimension)	millimeters
MS (Fastener)	Machine Screw
NS (as part number)	Item is not sold by Walker Manufacturing
OD	Outside Diameter
oz	ounce
PFH (Fastener)	Phillips Flat Head
P/N	Part Number
PPH (Fastener)	Phillips Pan Head
PTH (Fastener)	Phillips Truss Head
PTO	Power Take-Off
QKS	Quick Slide
qt	quart
RH	Right Hand (orientated with operator on seat)
SAE (Fastener)	Society of Automotive Engineers
SBH (Fastener)	Socket Button Head (Bolt)
SD	Side Discharge
SFH (Fastener)	Slotted Flat Head
SHC (Fastener)	Socket Head Cap
SHL (Fastener)	Shoulder (Bolt)
SM (Fastener)	Sheet Metal (Screw)
S/N	Serial Number
Spg	Spring
SQH (Fastener)	Square Head
SS (Fastener)	Stainless Steel
ST (Fastener)	Self-Tapping (Screw)
Term	Terminal
V	Volts

NOTE: In some instances, combinations of abbreviations may be used (e.g. PPHMS - Phillips Pan Head Machine Screw).

Beginning S/N 125718

Effective Date 11-25-13

Use only genuine **Walker®** replacement parts.

ILLUSTRATED PARTS LIST

<i>Section of Tractor Covered</i>	<i>Page</i>	<i>Section of Tractor Covered</i>	<i>Page</i>
<hr/>		<hr/>	
Decals		Electrical Components	
Tractor Decals	2	Electrical Assembly	26
Body / Chassis Assemblies		Electrical Assemblies (GHS 7.0 Bushel Components).....	28
Body / Chassis Assembly	4	Electrical Connectors.....	30
Rear Body Assembly.....	6	Maintenance	
Tractor Components		Lubrication Points	32
Main Component Power Transmission	8	Wiring Schematic.....	34
Engine Group.....	10	Operator's Notes	35
Hydrostatic Ground Drive Assemblies.....	12	Warranty	
Steering Control Assemblies.....	14	Limited Warranty.....	37
Throttle & Choke Control Assemblies.....	16		
Parking Brake Assembly.....	18		
GHS Group.....	20		
GHS Powerfil® Assembly (7.0)	22		
GHS 7.0 Bushel Catcher Assembly.....	24		

TRACTOR DECALS

ITEM NO.	PART NO.	DESCRIPTION	LOCATION	NO. REQUIRED
Walker Product and Operation Decals				
1	8600-33	RH Fender	Body, RH Near Seat	1
2	5800-11	Walker (8" Round)	7.0 Bushel Catcher (one on each side)	2
3	8600-35	LH Fender	Body, LH Near Seat	1
4	8821-8	Decal, C19	Body	1
5	5856-1	Made in USA	Body	1
Danger Decals Warning Decals Caution Decals				
6	8600-10	Danger, Pinch Point	7.0 Bushel Catcher Mounting Frame Assembly (one on each side)	2
7	8600-4	Danger, Rotating Blower Blades	Body, Near Body Chute	1
8	8600-12	Danger, Engine Exhaust	Front Body, LH Side	1
9	5810-3	Decal, Hydro Warning	Bridge Assembly and LH Gear Axle Drive Assembly	2
Maintenance Decals				
10	5082-5	Fuel Recommendations	Front Body, RH Side	1
11	5855	Important, Engine Cooling	Engine	1
12	5869	Removable Screen	7.0 Bushel Catcher Removable Screen	1
13	8600-16	Front Body Closure	Rear Cross Member, Body	1
14	5810-1	Axle Oil Level	Gear Axle Drive Assemblies (one on each)	2
15	6875	PTO Alignment Arrow	Universal Joint Tube Assembly	1
16	6807-1	Oil Pressure	Body	1
17	NS	Sealed Reservoir	Hydrostatic Drives (one on each)	2
18	8600-30	Parking Brake	Body, RH Side Below Seat	1
19	7827	Oil Level	Jackshaft Support	1
20	8600-23	Body Latch Decal	Body, RH Side Below Seat	1

NOTE: All parts requiring decals are shipped with decals applied.

TRACTOR DECALS

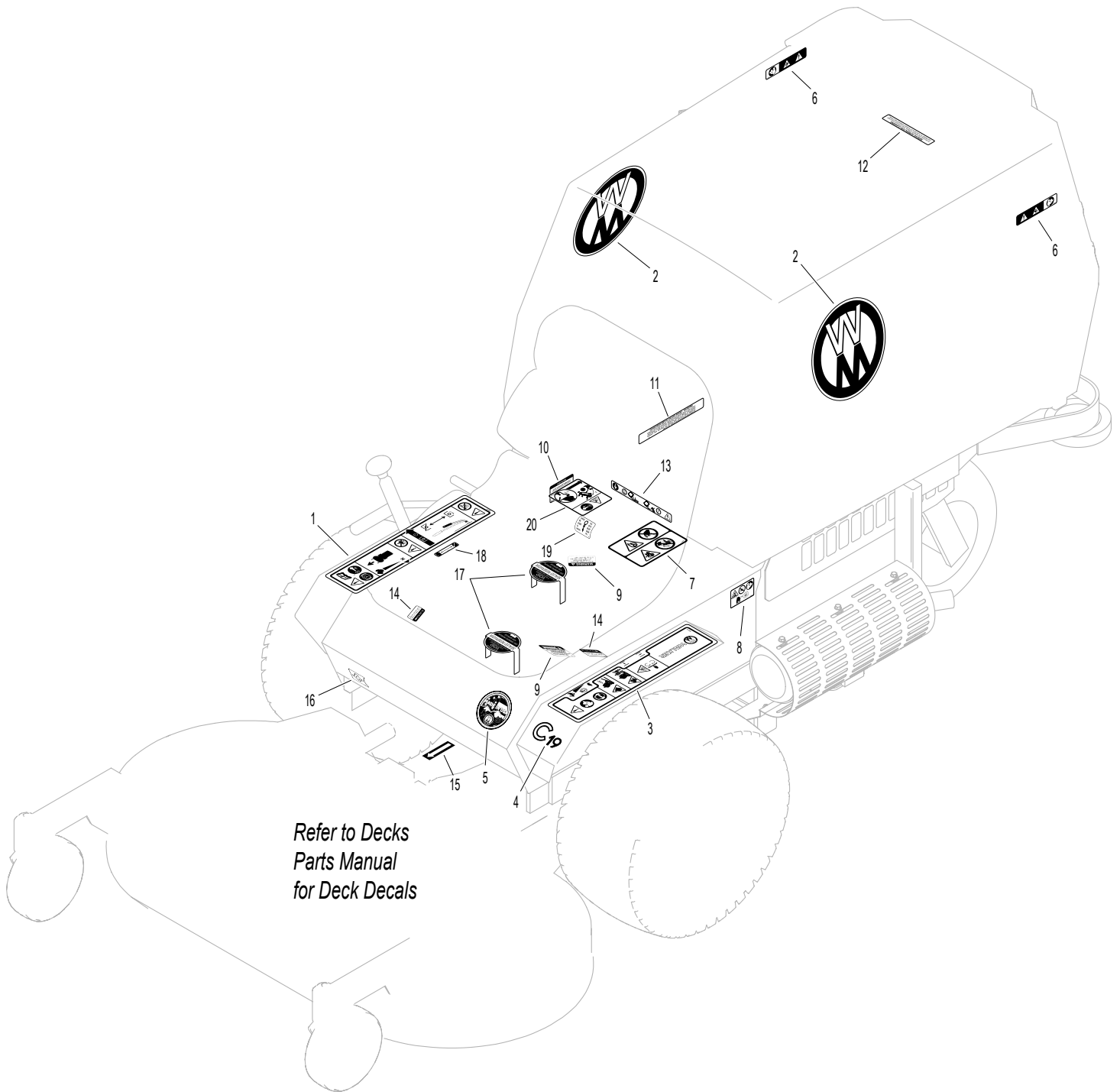

BODY / CHASSIS ASSEMBLY

ITEM NO.	PART NO.	DESCRIPTION	NO. REQ'D	ITEM NO.	PART NO.	DESCRIPTION	NO. REQ'D
Seat Assembly				38	5038-1	Axle Spacer Tube (6-5/8)	1
1	5103	Seat	1	39	6307-2	Chassis Frame	1
2	7223-1	Compression Spring	2	40	5075-1	LP Wheel & Tire (18 x 8.50-10)	2
3	7846	Washer (3/8 ID x 1-1/4 OD x 1/8)	2		5075-2	LP Tire (18 x 8.50-10)	*
4	5841-1	Retainer Washer	2		5075-5	LP Wheel (10 x 7)	*
5	7845-1	Rubber Bumper (1.375 x .750)	2		5033-6	Wheel & Tire (18 x 7.00-8)	**
6	5841	Retainer Washer (3/8 x 1-1/4)	2		5030-6	Standard Tire (18 x 7.00-8)	*
7	7440-5	Shock Mount (1-1/4 x 3/4)	2		5031-2	Standard Wheel (8 x 5.5)	*
					5030-4	Tire Tube (18 x 8.50-8)	*
Rear Bumper Assembly				Fasteners			
8	7516-5	Catcher Pivot Bushing	2	F002	10-24 Keps Nut		4
9	5517-8	7.0 Rear Bumper	1	F004	1/4-20 Keps Nut		2
10	7517-2	Catcher Pivot Plate	2	F005	1/4-20 ESNA Nut		1
11	5162	Roller Wheel (5" Rubber)	2	F009	5/16-18 Whiz Locknut		9
Body Assembly				F012	3/8-16 Keps Nut		8
12	2505	Leaf Spring	1	F013	3/8-16 Whiz Locknut		2
13	5845	Rubber Bumper (1.50 OD x 1.25)	4	F014	3/8-16 ESNA Nut		4
14	NS	Body ID Plate	1	F016	1/2-13 Self-Locking Nut		1
15	7383-3	Body Latch Hook (2-1/2 Side Bars)	1	F020	5/16-18 ESNA Nut		1
16	7854	Plastic Tip, Red	1	F025	10-24 x 3/8 PPHMS		4
17	5989-12	Dome Plug (3/16)	1	F029	1/4-20 x 1/2 Hex Bolt		2
18	5989-10	Dome Plug (9/16)	1	F031	1/4-20 x 5/8 Hex Bolt		1
19	8118	Heat Deflector	1	F038	3/8-16 x 1 Hex Bolt		6
20	5989-5	Dome Plug (7/16)	4	F040	3/8-16 x 1-1/2 Hex Bolt		2
21	5989-4	Dome Plug (3/8)	3	F042	3/8-16 x 2-1/4 Hex Bolt		2
22	6100-19	Front Body	1	F048	1/2 SAE Washer		2
23	7146	13mm Ball Stud	2	F050	1/4 SAE Washer		1
24	2145	Gas Spring Assembly (Includes Item # 23)	1	F051	3/8 SAE Washer		2
25	5180	Edge Molding, Lever Opening	2	F059	3/8 Wave Spring Washer		2
Tilt-Up Latch Assembly***				F093	5/16-18 x 1 Hex Bolt		1
26	5847	Plastic Tip	1	F151	3/8-16 x 7/8 Hex Bolt		2
27	5744-20	Spring Arm, Tilt-Up Latch	1	F157	1/2-20 x 1-1/4 Wheel Lug Bolt		8
28	5744-10	Spring Pivot Bushing	1	F206	#2 x 3/16 Drive Pin		2
29	5744-15	Compression Spring (3/8 x 5/8)	1	F227	3/8 x 1-1/4 x 1/8 Plastic Washer		2
30	5744-13	Mount Angle, LH	1	F241	.375 x .875 x .10 Washer		4
31	5744-12	Hook, Tilt-Up Latch	1	F257	3/8 x 1-11/16 Shoulder Bolt		2
32	5744-14	Mount Angle, RH	1	F292	1/2-13 x 8-1/2 Hex Bolt, GR 2		1
Chassis Assembly				F341	Coil Roll Pin (7/64 x 9/16)		1
33	5267-1	Retainer Collar (1") (Includes Item # F413)	1	F342	5/16 Conical Washer		2
34	5270-1	Pivot Bearing	2	F413	5/16-24 x 5/16 Set Screw		2
35	5420-2	Tail Wheel Fork	1				
36	5037-1	Bearing, Tail Wheel	2				
37	5035	Tail Wheel & Tire Assembly (13 x 6.50-6)	1				
	5035-1	Tail Wheel Tire (13 x 6.50-6)	*				
	5036	Tail Wheel & Hub (6 x 4.5)	*				

* Service Part Only

** May be ordered as a factory-installed option or for dealer installation. Narrow Drive Tires are used when installing a 36" Deck. Contact your Walker dealer.

*** Complete Tilt-Up Latch Kit available by ordering kit P/N 5747.

Beginning S/N 125718

Effective Date 11-25-13

Use only genuine **Walker**® replacement parts.

BODY / CHASSIS ASSEMBLY

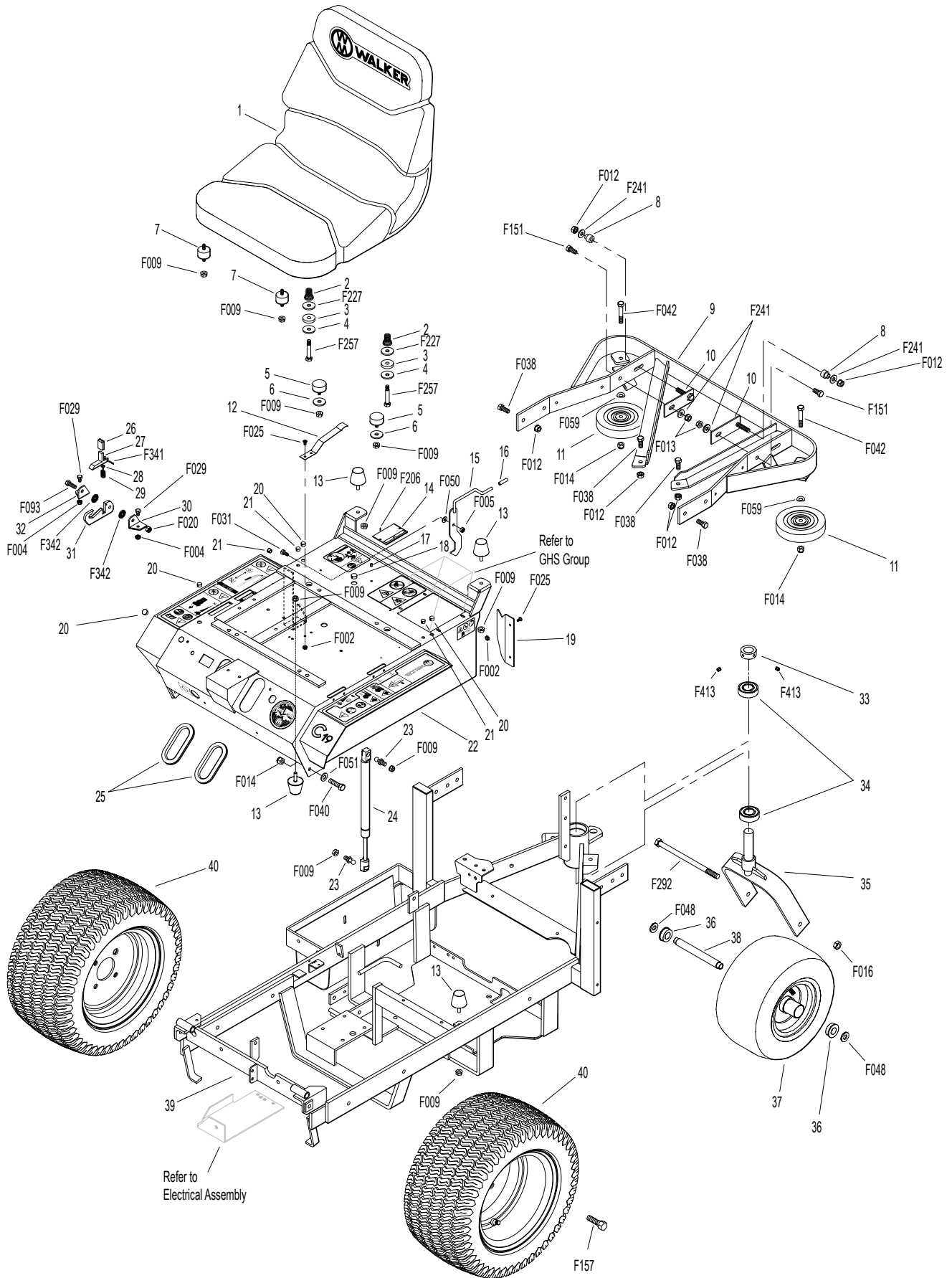

Beginning S/N 125718
 Effective Date 11-25-13
 Use only genuine **Walker**® replacement parts.

REAR BODY ASSEMBLY

ITEM NO.	PART NO.	DESCRIPTION	NO. REQ'D	ITEM NO.	PART NO.	DESCRIPTION	NO. REQ'D
Rear Body Assembly				Fasteners			
1	5976	Grommet (3/8 x 11/16)	1	F002		10-24 Keps Nut	8
2	5105-1	Rear Body Cover	1	F004		1/4-20 Keps Nut	5
3	8515-14	Catcher Handle Plate, RH	1	F009		5/16-18 Whiz Locknut	2
4	8389-4	Splash Guard	1	F025		10-24 x 3/8 PPHMS	4
5	7146	13mm Ball Stud	2	F026		10-24 x 1/2 PPHMS	4
6	7147	Spring Clip	2	F031		1/4-20 x 5/8 Hex Bolt	2
7	7145	Gas Spring Assembly (Includes Items # 5 & 6)	1	F032		1/4-20 x 3/4 Hex Bolt	1
8	7190-1	Insulation Foam Pad, LH	1	F390		1/4-20 x 7/8 Carriage Bolt	2
9	7190-2	Insulation Foam Pad, RH	1	NOTE: Rear Bumper Assembly for GHS Models is not shown here. Refer to BODY / CHASSIS ASSEMBLY , Page 4.			
10	5105	Rear Body Panel	1				
11	8515-13	Catcher Handle Plate, LH	1				

REAR BODY ASSEMBLY

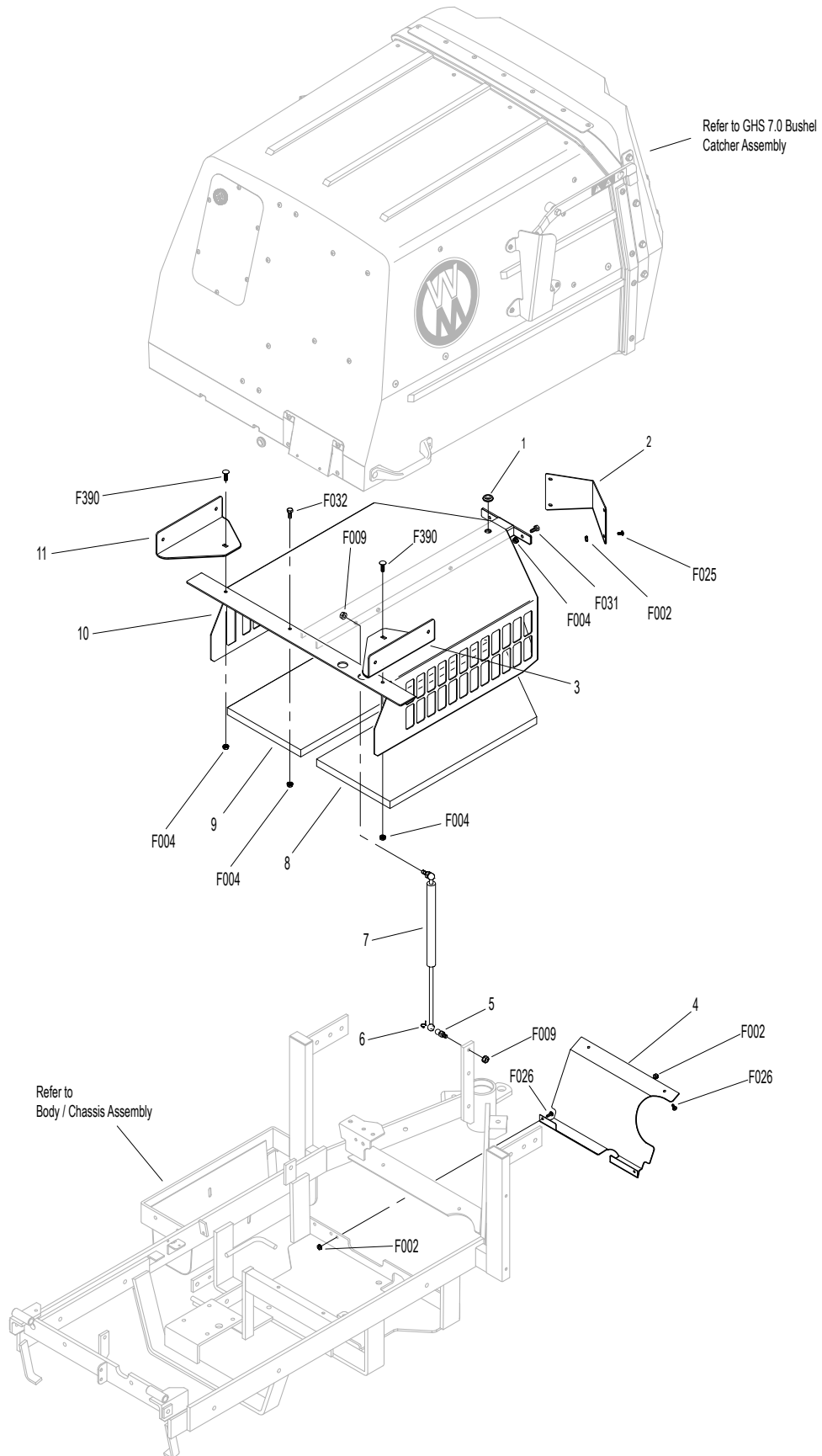

Beginning S/N 125718
Effective Date 11-25-13
Use only genuine **Walker**® replacement parts.

MAIN COMPONENT POWER TRANSMISSION

ITEM NO.	PART NO.	DESCRIPTION	NO. REQ'D	ITEM NO.	PART NO.	DESCRIPTION	NO. REQ'D
Clutch Lever Assembly				44	5221-1	Extension Spring (3/4 x 5)	2
1	6358-1	Clutch Lever (Includes Items # 2 & 3)	1	45	7833	Cable Clamp (7/8 x 1/4)	2
2	5830	Grease Fitting	7	46	8539	Starter Relay Mount	1
3	4850	Handle Grip, Black	1	47	7241-2	Transmission Drive Pulley (3-1/4MV) (Includes Items # F067 & F171)	1
4	7303-10	Clutch Actuator Bolt (3/8)	1	48	5268	Bearing with Collar (3/4)	2
5	7380-5	Knuckle Joint (3/8 ID)	1	49	8349	Transmission Belt Tightener Arm	1
6	7226-10	Compression Spring (3/4 x 2-1/2)	1	50	8393-7	Hydro Jackshaft Mount	1
7	8130-5	Pushrod, Clutch Actuator (Threaded Tube) (Includes Item # 2)	1		8394-1	Hydro Jackshaft Mount Assembly (Includes Items # 2, 9, 43, 48, 50 & 51)	*
8	8130-10	Clutch Actuator Rod Assembly (Includes Items # 2, 4-7, F054, F336 & F353)	1	51	8273	Jackshaft (3/4 x 7-1/2)	1
9	7201-3	Fiberglide Bearing	6	52	7240-4	Jackshaft Drive Pulley (3.3/3V) (Includes Items # F067 & F171)	1
10	7201-5	Inner Race (2-1/4)	1	Fasteners			
11	8368	PTO Belt Tightener	1		F002	10-24 Keps Nut	1
12	5841	Retainer Washer (3/8 x 1-1/4)	4		F003	1/4-28 Hex Nut	2
13	8243-1	Clutch Idler Pulley	1		F004	1/4-20 Keps Nut	3
	8243	Clutch Idler Pulley Assembly (Includes Items # 13-15 & F070)	*		F005	1/4-20 ESNA Nut	1
14	5265	Bearing (3/4)	1		F009	5/16-18 Whiz Locknut	3
15	8243-3	Hub, Idler Pulley	1		F012	3/8-16 Keps Nut	8
16	8375	PTO Belt Tightener Stop	1		F025	10-24 x 3/8 PPHMS	1
17	7377	Plastic Washer (1 x .438 x .025)	2		F029	1/4-20 x 1/2 Hex Bolt	1
18	7378	Pivot Bearing (7/16 x 9/16)	1		F034	5/16-18 x 3/4 Hex Bolt	2
19	5281-1	Clevis Spring Pin	1		F040	3/8-16 x 1-1/2 Hex Bolt	1
20	5280	Clevis (1/4)	2		F041	3/8-16 x 1-3/4 Hex Bolt	2
21	8305	Brake Actuator Rod	1		F042	3/8-16 x 2-1/4 Hex Bolt	3
22	8370	Bearing, Brake Actuator	1		F043	3/8-16 x 3 Hex Bolt	1
23	5281-5	Clevis Pin (1/4 x 0.80)	1		F047	3/8-16 x 4-1/2 Hex Bolt	1
24	8250	Brake Spring (1/2 x 2-1/2)	1		F054	AN960616 Washer	3
25	8369	Brake Actuator (Includes Items # 2 & 22)	1		F061	1/4 Internal Star Lock Washer	1
PTO Drive Shaft Assembly					F067	3/16 x 3/16 x 1 Key	2
26	7050-1	Dipstick, Gearbox	1		F069	3/32 x 1/2 Cotter Pin	1
27	8371-1	Mount Bracket, Brake Band	1		F070	1-3/4 Internal Snap Ring	1
28	8377	Brake Band Guide	1		F090	1/4-20 x 2-1/2 Hex Bolt	1
29	8050-11	PTO Gearbox / Flange Pulley	1		F116	1/4-20 x 1-1/4 Hex Bolt	1
30	5245	Idler Pulley (3")	2		F121	5/16-18 x 3/8 x 1 SHL Bolt	1
31	7248	Ground Drive Belt, Micro-V	1		F131	5/16-18 x 1/2 Hex Bolt	2
32	7275-9	Quick Coupler Installation Tool	**		F132	1/4-20 x 2-3/4 Hex Bolt	1
33	7275-16	Universal Joint Tube Assembly (Spline)	1		F168	5/16 Split Lock Washer	14
34	8304	Brake Band (14-1/2)	1		F171	5/16-18 x 3/8 Set Screw	4
35	7523-2	Clevis Pin W/Hole (1/4 x 5/8)	1		F178	1/4 x 1 Fender Washer	1
36	6250-1	Drive Belt (3VX370)	1		F182	1/4 x 5/8 x 1/8 Washer	2
37	7236-1	PTO Drive Pulley (4-1/2/3V) (Includes Items # F168 & F226)	1		F186	5/64 x 1/2 Cotter Pin	1
38	8237-2	Engine Pulley, Bolt On (4/3.8/3V) (Includes Items # F168 & F226)	1		F226	5/16-18 x 7/8 Hex Bolt	14
39	8230	Engine PTO Belt	1		F241	.375 x .875 x .10 Washer	1
Jackshaft Assembly					F261	AN960616L Washer	1
40	7245-1	Idler Pulley (3/8 Groove)	1		F336	3/8-16 Jam Nut	1
41	6325-2	Spacer Bushing (5/16)	2		F353	3/8-16 ESNA LP Nut	1
42	8349-2	Idler Arm	1	* Service Part Only			
43	7201-4	Inner Race (1-1/2)	2	** The Quick Coupler Installation Tool is used to assist the installation of the Quick Coupler Tube and PTO Shaft connection by holding the disconnect ring in the retracted position when joined to the tractor spline shaft on the PTO gearbox.			

MAIN COMPONENT POWER TRANSMISSION

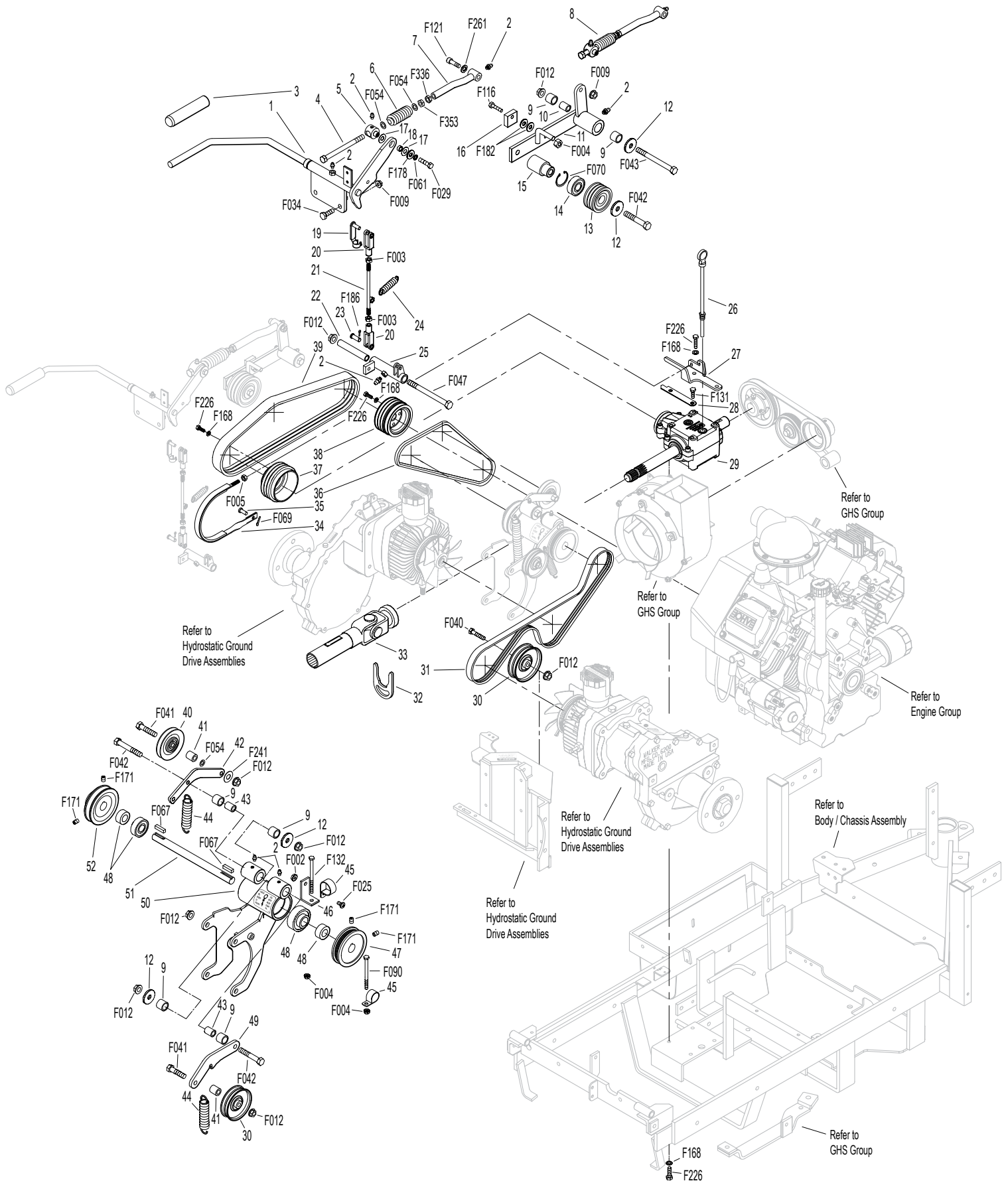

Beginning S/N 125718
 Effective Date 11-25-13
 Use only genuine **Walker**® replacement parts.

ENGINE GROUP

ITEM NO.	PART NO.	DESCRIPTION	NO. REQ'D	ITEM NO.	PART NO.	DESCRIPTION	NO. REQ'D
Precleaner Assembly				34	8023	Fuel Tank Support	1
1	6087-2	Air Intake Hose	1	35	5086-7	Hose (1/4 x 6)	1
2	7840-5	Hose Clamp (1-1/2 to 2)	2	36	5020-2	Fuel Filter, In Tank	1
3	NS	Air Cleaner Band	1	37	6046-3	Fuel Tank, 2.8 Gallon, Gas (Includes Item # 30)	1
4	5091-4	Indicator Nipple	1	Fasteners			
5	5091-2	Air Flow Indicator (Vacuum 10" H2O)	1	F002	10-24 Keps Nut		2
6	6090-12	Air Cleaner Assembly (Straight) (Includes Items # 3-5, 7-9, F009 & F091)	*	F004	1/4-20 Keps Nut		4
7	5090-3	Safety Filter Insert	1	F009	5/16-18 Whiz Locknut		5
8	5090-1	Air Cleaner Cartridge	1	F012	3/8-16 Keps Nut		2
9	7334-3	Air Cleaner Bracket	1	F025	10-24 x 3/8 PPHMS		2
Engine & Exhaust Assemblies				F029	1/4-20 x 1/2 Hex Bolt		2
10	8016-4	Regulator Mount	1	F031	1/4-20 x 5/8 Hex Bolt		2
11	NS	19 HP Kohler Engine	1	F038	3/8-16 x 1 Hex Bolt		1
12	NS	Oil Filter (Kohler 2805001)	1	F050	1/4 SAE Washer		4
13	NS	Gasket (Kohler 2404102)	2	F051	3/8 SAE Washer		2
14	NS	Nut (Kohler M-0841080)	4	F061	1/4 Internal Star Lock Washer		2
15	6013-15	Muffler	1	F063	3/8 Internal Star Lock Washer		4
16	6013-7	Muffler Heat Shield	1	F079	A/A66D Aluminum Pop Rivet		1
17	6013-29	Muffler Heat Deflector	1	F091	5/16-18 x 5/8 Hex Bolt		4
18	6013-16	Muffler Brace	1	F106	3/8-16 x 5/8 Hex Bolt		2
19	8021	Engine Brace	1	F120	AN960416 Washer		2
20	8010-2	Engine Bumper Mount	1	F151	3/8-16 x 7/8 Hex Bolt		2
21	5845	Rubber Bumper (1.50 x 1.25)	1	F184	1/4-20 x 1/2 Hex Bolt, SS		7
Fuel Tank Assembly				F185	1/4 Internal Star Lockwasher, SS		5
22	5082-4	2-1/4 Ratchet Fuel Cap	1	F218	7/16 Split Lock Washer		4
23	5977-7	Roll Over Grommet (.900 x 1-1/2)	1	F219	7/16-14 x 1-1/4 Hex Bolt		4
24	8043-8	Roll Over Valve	1	F273	M6 x 1.0 Nut		4
25	M113	Fuel Line (3/16 x 26-1/2")	1**	F274	M6 x 1.0 x 45 Stud		2
26	5083-7	Tank Tube (8-1/2")	1	* Service Part Only			
27	5879-3	Hose Clamp (1/2)	4	** Required hose specifications:			
28	5975-3	Cable Tie (50# x 7")	1	M113 - 3/16" ID fuel/oil/vapor hose (Gates 4219-0093 or equivalent)			
29	M247	Fuel Line, Tank (5/16 x 9")	1**	M247 - 5/16" ID low permeation (<15g/m ² /day) fuel hose (Parker 38905 or equivalent)			
30	5083-1	Bushing, Rubber	*	NOTE: Refer to Kohler Engine Decal (NS) for Engine Identification Numbers.			
31	7833	Cable Clamp (7/8 x 1/4)	1				
32	5020	Fuel Filter	1				
33	NS	Fuel Line, Engine (Kohler)	*				

HYDROSTATIC GROUND DRIVE ASSEMBLIES

ITEM NO.	PART NO.	DESCRIPTION	NO. REQ'D	ITEM NO.	PART NO.	DESCRIPTION	NO. REQ'D
Transmission Lockout Assembly				Transmission Repair Parts			
1	5028-3	Transmission Lockout Assembly (Includes Items # 2-5, F023, F027 & F081)	*	26	5025-5	Input Shaft	*
2	5847	Plastic Tip	2	27	5025-8	Bearing, Input Shaft	*
3	5057	Lockout Cam (Includes Item # F081)	2	28	5025-7	Snap Ring	*
4	5028-5	Lockout Lever	2	29	5025-2	Seal, Input Shaft	*
5	5027-5	Lockout Mount	1**	30	5022	Reservoir to Casting Gasket	*
Ground Drive Assemblies				31	5024	Reservoir Cap and Gasket	*
6	6209-3	Bridge Assembly	1	32	5023	Transmission Reservoir Kit	*
7	6243-2	Hydro Fan, CCW	1	33	5023-1	Rubber Bladder	*
8	5026	Hydrostatic Drive, CW (700-051)	1	34	5025-6	O-Ring & Plug Assembly	*
9	6206-1	Air Vent Valve	*	35	5025-3	Seal, Control Shaft	*
10	6200-9	Gear Axle Drive Assembly (Includes Items # 9 & 11)	2	Fasteners			
11	6207-12	Pipe Plug (1/4 NPTF)	4	F012	3/8-16 Keps Nut		1
12	5126	Cable Retainer (Uses existing bolt on Gear Axle Drive Assembly)	1	F023	10-24 ESNA Nut		2
13	6233-1	Pinion Gear	2	F027	10-24 x 5/8 PPHMS		2
14	6234	Spacer, Pinion Gear	2	F036	1/4-20 x 1/2 SBH Screw		2
15	6201	O-Ring Seal	2	F038	3/8-16 x 1 Hex Bolt		4
16	7244	Hydro Pulley (3-7/8/MV) (Includes Items # F064 & F359)	2	F040	3/8-16 x 1-1/2 Hex Bolt		4
17	6243-1	Hydro Fan, CW	1	F043	3/8-16 x 3 Hex Bolt		6
18	5025	Hydrostatic Drive, CCW (700-052)	1	F051	3/8 SAE Washer		2
Deck Support Arm Assemblies				F053	7/16 Internal Star Lock Washer		4
19	6430-10	Outboard Mount, LH	1	F063	3/8 Internal Star Lock Washer		15
20	6431-1	Deck Support Arm, LH (Includes Item # 24)	1	F064	1/8 x 1/2 Woodruff Key (#3)		4
21	5775-2	Hitch Pin (# 6)	2	F081	A/A45D Aluminum Pop Rivet		2
22	6431-2	Deck Support Arm, RH (Includes Item # 24)	1	F160	External Snap Ring (.669 Shaft)		2
23	6430-9	Outboard Mount, RH	1	F178	1/4 x 1 Fender Washer		2
24	5830	Grease Fitting	2	F194	7/16 x 1-1/4 x 1/8 Washer		2
25	6840-1	Support Arm Bushing (2-1/16)	2	F200	7/16-20 x 3 Grade 8 Bolt		2
				F244	7/16-20 x 3/4 Hex Bolt		2
				F262	3/8-16 x 4 Hex Bolt All Thread		1
				F359	5/16-18 x 5/16 Set Screw (Unbrako Knurl Point)		4
				F416	3/8-16 x 4 Socket Head Cap Screw		1
				* Service Part Only			
				** Part not used on Jackshaft side of tractor.			

STEERING CONTROL ASSEMBLIES

ITEM NO.	PART NO.	DESCRIPTION	NO. REQ'D	ITEM NO.	PART NO.	DESCRIPTION	NO. REQ'D
Transmission Spring Assemblies				30	5470-1	Speed Control Stop	1
1	6201-2	Shock Mount Gear Drive, RH	1	31	5450-10	Steering Lever Assembly, RH / Adjustable (Includes Items # 9, 10, 16, F360 & F489)	1
2	5146	10mm Ball Stud	4		5450-7	Steering Lever Arm, RH / Adjustable	*
3	5199-3	Steering Lever Dampener Assembly	2	32	5862	FSC Knob	1
4	6201-1	Shock Mount Gear Drive, LH	1	33	7170	FSC Lever Assembly (Includes Item # 16)	1
5	5214-2	Ball Joint (5/16-24) Nylon Lined	2	Fasteners			
6	6212-1	Transmission Control Arm, LH	1		F003	1/4-28 Hex Nut	1
7	5213-3	Control Rod (6")	1		F004	1/4-20 Keps Nut	6
8	5665-1	Compression Spring (2-1/2)	2		F007	5/16-18 Jam Nut	1
9	5463-2	Steering Lever Actuator	2		F008	5/16-24 Keps Nut	2
10	7201-2	Fiberglide Bearing 1/2"	2		F009	5/16-18 Whiz Locknut	5
11	5213-4	Control Rod (14-3/4")	1		F010	5/16-24 ESNA Nut	2
12	5212	Transmission Control Arm, RH	1		F024	5/16-24 Jam Nut	2
Steering Lever & FSC Assemblies					F029	1/4-20 x 1/2 Hex Bolt	2
13	5173	FSC Actuator Rod	1		F032	1/4-20 x 3/4 Hex Bolt	4
14	5172	Bearing, Delrin (.255 ID x .379 OD x .250)	1		F034	5/16-18 x 3/4 Hex Bolt	1
15	5142-2	FSC Actuator Cam	1		F050	1/4 SAE Washer	3
16	5830	Grease Fitting	6		F051	3/8 SAE Washer	2
17	5141	FSC Friction Washer (1-1/2 x 3/8 x 1/16)	2		F064	1/8 x 1/2 Woodruff Key (#3)	2
18	5140-16	FSC Friction Body (Includes Item # 16)	1		F068	1/8 x 1 Cotter Pin	1
19	5142-7	FSC Key W/Stop	1		F069	3/32 x 1/2 Cotter Pin	1
	5140-14	FSC Control Assembly (Includes Items # 15-19, F192 & F193)	*		F093	5/16-18 x 1 Hex Bolt	1
20	5850-2	Handle Grip, Foam (5-1/2)	2		F183	.312 x .700 x .074 Washer	2
21	5223	Extension Spring (1/4 x 5-1/2)	2		F186	5/64 x 1/2 Cotter Pin	1
22	5450	D-Clip	2		F188	1/4-20 Self-Locking Nut	4
23	5391-3	Steering Lever Support	1		F192	3/8-24 Self-Locking Nut	1
24	5217	Pivot Pin, Steering Lever	1		F193	3/8 Belleville Spring Washer	3
25	5451-10	Steering Lever Assembly, LH / Adjustable (Includes Items # 9, 10, 16, F360 & F489)	1		F198	.250 x .625 x .040 Washer, SS	2
	5451-7	Steering Lever Arm, LH / Adjustable	*		F345	1/4-20 x .770 Knurled Bolt	4
26	5453-10	Steering Lever Handle, Adjustable (Includes Items # 20 & F345)	2		F350	1/4-20 LP Nylock	2
27	5219	Extension Spring (3/4 x 6-3/4)	1		F360	1/4-20 x 3/8 Hex Bolt	2
28	5280	Clevis (1/4")	1		F401	.504 x .751 x .030 Washer	1
29	5281-5	Clevis Pin (1/4 x 0.80)	1		F489	Washer 1/4 x 7/8 x .090	2
				*	Service Part Only		

THROTTLE & CHOKE CONTROL ASSEMBLIES

ITEM NO.	PART NO.	DESCRIPTION	NO. REQ'D	ITEM NO.	PART NO.	DESCRIPTION	NO. REQ'D
Throttle & Choke Control Assemblies				Fasteners			
1	8121-1	Throttle Cable	1		F002	10-24 Keps Nut	4
2	8122-1	Choke Cable	1		F005	1/4-20 ESNA Nut	2
3	5172	Bearing, Delrin (.255 x .379 x .250)	2		F025	10-24 x 3/8 PPHMS	4
4	5108-7	Control Lock Tab	2		F050	1/4 SAE Washer	2
5	5108-10	Friction Washer (.125)	2		F164	10-24 x 1/4 x 3/8 SHL Bolt	2
6	5108-1	Control Lever, Throttle & Choke	2		F201	1/4 Belleville Spring Washer	4
7	5108-5	Throttle Control Knob, Red	1				
8	5108-11	Friction Washer (.062)	2	*		Service Part Only	
9	5108-8	Control Bracket	2				
10	7108	Control Assembly (Includes Items # 4-6, 8, 9 & F201)	2				
	8121	Throttle Control and Cable Assembly (Includes Item # 7)	*				
	8122	Choke Control and Cable Assembly (Includes Item # 11)	*				
11	5108-6	Choke Control Knob, Black	1				
12	8123	Insulation Sleeve (3/8 x 6)	1				
13	5975-3	Cable Tie (50# x 7")	1				
14	5975-1	Cable Tie (18# x 3-3/4")	1				

THROTTLE & CHOKE CONTROL ASSEMBLIES

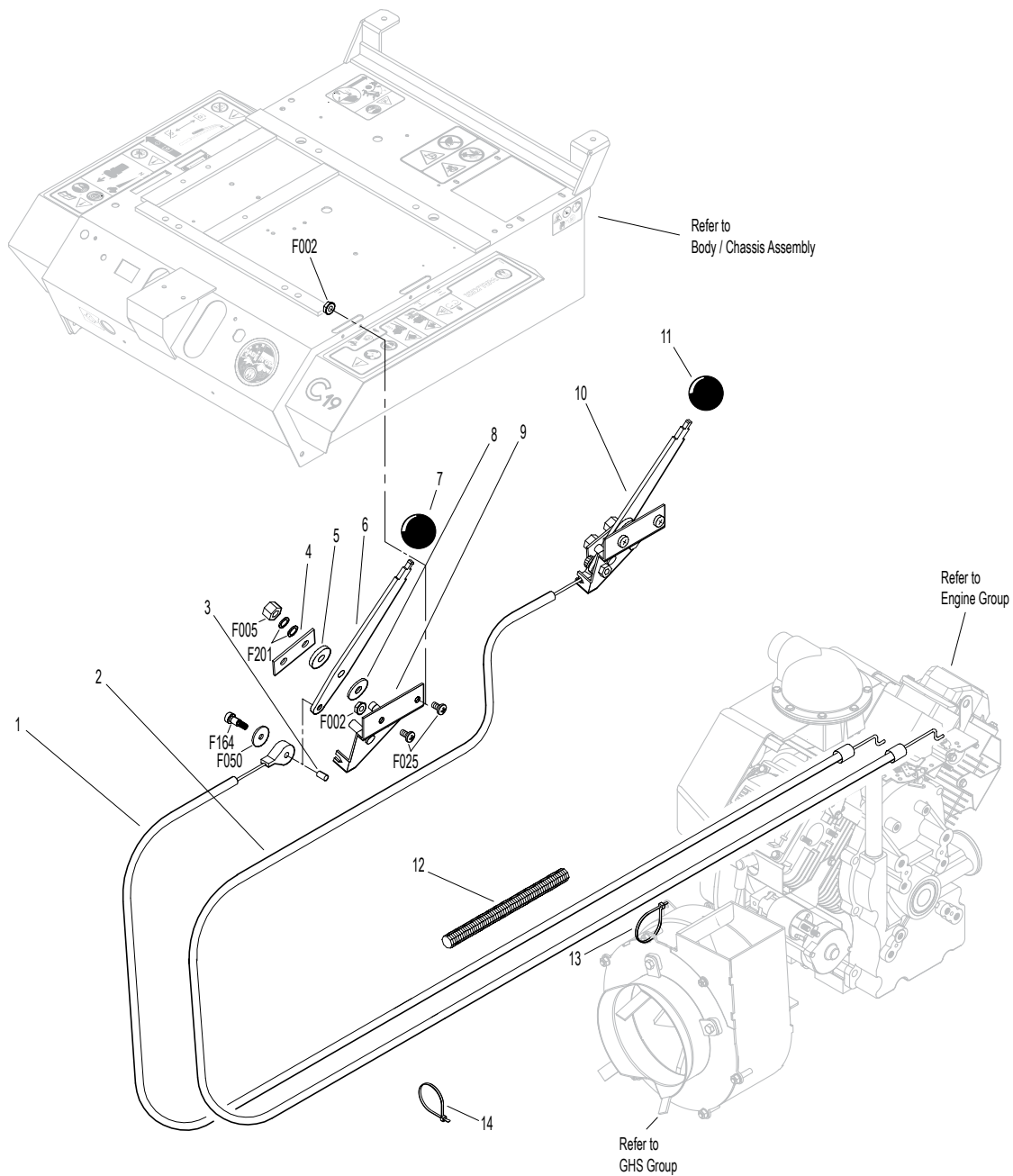

Beginning S/N 125718
Effective Date 11-25-13
Use only genuine **Walker**® replacement parts.

PARKING BRAKE ASSEMBLY

ITEM NO.	PART NO.	DESCRIPTION	NO. REQ'D	ITEM NO.	PART NO.	DESCRIPTION	NO. REQ'D
Parking Brake Assembly				Fasteners			
1	7406-1	Handle Grip, Red	1	F002		10-24 Keps Nut	2
2	7406-8	Parking Brake Lever (4-1/4)	1	F003		1/4-28 Hex Nut	1
3	7406-2	Lever Mount	1	F004		1/4-20 Keps Nut	4
4	5830	Grease Fitting	1	F025		10-24 x 3/8 PPHMS	2
5	7407	Clevis Pin (3/16 x 1/2)	2	F029		1/4-20 x 1/2 Hex Bolt	3
6	7404	Brake Actuator Arm	2	F032		1/4-20 x 3/4 Hex Bolt	1
7	7405	Pin, Transmission Lock	2	F054		AN960616 Washer	2
8	7402	Clevis	2	F072		1/4 "E" Retainer Ring	2
9	7408	Compression Spring (1/2 x 3/4)	2	F086		#10 SAE Washer	4
10	7415	Rubber Dust Shield (5/8 x 3/8 x 1/32)	2	F109		1/8 x 5/8 Roll Pin	2
11	5567-3	O-Ring Seal (1/4 x 3/8)	4	F111		1/8 x 3/4 Cotter Pin	1
12	7403	Plunger Bushing, Gear Axle	2	F112		5/8 x 1-1/4 x .03 Washer	2
13	7404-1	Brake Actuator Mount	2	F127		1/16 x 1/2 Cotter Pin	4
14	7412	Clevis Pin (3/16 x 5/8)	2	F261		AN960616L Washer	5
15	5833	Cable Clamp (1/4)	2	F287		1/4-28 Keps Nut	1
16	7410	Brake Control Cable, LH (25.5")	1				
17	7409	Brake Control Cable, RH (20.5")	1				
18	7401-3	Cable Mount Bracket	1				
19	7401-1	Cable Pull Rod	1				
20	5552	Ball Joint (1/4-28)	1				

PARKING BRAKE ASSEMBLY

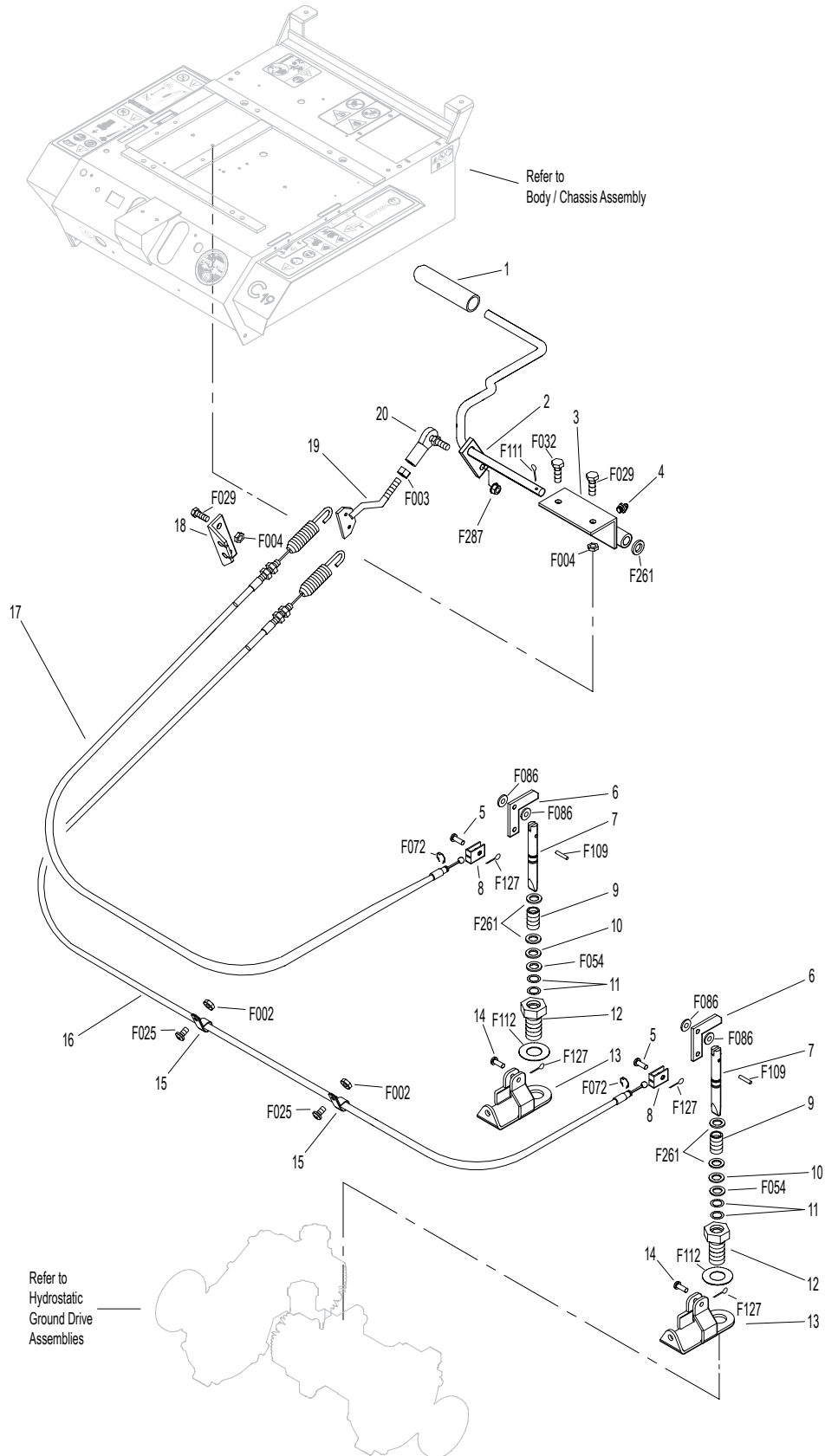

Beginning S/N 125718
 Effective Date 11-25-13
 Use only genuine **Walker**® replacement parts.

GHS POWERFIL® ASSEMBLY (7.0)

ITEM NO.	PART NO.	DESCRIPTION	NO. REQ'D	ITEM NO.	PART NO.	DESCRIPTION	NO. REQ'D
7.0 GHS Powerfil® Assembly				Fasteners			
1	5552	Ball Joint (1/4-28)	2	F002		10-24 Keps Nut	10
2	5553-3	Bushing, Powerfil® Actuator	4	F003		1/4-28 Hex Nut	3
3	5553-1	Compression Spring (1/2 x 2)	2	F026		10-24 x 1/2 PPHMS	1
4	5558-2	Powerfil® Actuator Rod	1	F037		10-24 x 5/8 PTH Screw	2
	5549	Actuator Rod Assembly (Includes Items # 1-5 & F003)	*	F054		AN960616 Washer	1
5	5558-1	Powerfil® Push Rod	1	F085		3/16 Rivet Backup Washer	1
6	5551-3	Bearing Cap, Powerfil®	1	F101		10-24 x 1-1/4 SHC Screw	1
7	5551-1	Pivot Bearing (#S3PP)	2	F109		1/8 x 5/8 Roll Pin	1
8	5518-2	Pivot, Delivery Spout	1	F129		10-24 x 1/2 PTHMS	6
9	5517-2	Pivot Mount	1	F261		AN960616L Washer	1
10	5519-5	Actuator Motor (12V) (Includes Items # 11 & 12)	1	F287		1/4-28 Keps Nut	1
11	5519-2	Motor Mount Washer	*	* Service Part Only			
12	5519-3	Motor Mount Nut (5/8-24)	*				
13	5554	Actuator Arm	1				

GHS 7.0 BUSHEL CATCHER ASSEMBLY

ITEM NO.	PART NO.	DESCRIPTION	NO. REQ'D	ITEM NO.	PART NO.	DESCRIPTION	NO. REQ'D
Upper Baffle Screen Assembly (Removable)				37	7510-2	7.0 Bushel Catcher Box	1
					7502-5	7.0 Catcher W/Powerfil® (Includes Door)	*
1	7512-6	Removable Screen (3/16 Hole) (Includes Items # 2, F025 & F190)	1**	38	7607-8	Powerfil® Cover Plate	1
2	7506	Knob / Threaded Insert (10-24)	2	39	7608-2	Hinge Plate, RH	1
3	7509-2	Channel Top	2	40	8155-4	7.0 Gas Spring Cover, RH	1
4	8606-2	Channel Bottom	2	41	7607-12	Catcher Door Arm, RH	1
5	6856-1	Edge Molding (21-3/8")	1	42	7584-3	Reinforcing Strap	1
6	6507	Screen Seal (24")	1	43	5801-3	Decal Plate, Round (Set of 2)	1
7	7505	Mustache Spring	2	5598-2 Optional Dump Bag (Not Shown)			
8	7509-6	C-Channel With Spring (Includes Items # 7 & F340)	1	May be ordered as an option. Contact your Walker dealer.			
7.0 Exhaust Deflector Door Assembly				Fasteners			
9	7607-3	Upper Door Seal	1	F002	10-24 Keps Nut		23
10	7510-4	7.0 Catcher Box Door (Includes Frame) (Includes Items # 9, 11, 12, 14, F079, F085, F330 & F411)	1	F004	1/4-20 Keps Nut		23
11	5583	Handle	1	F009	5/16-18 Whiz Locknut		2
12	7607-6	Lower Door Stiffener (7.0)	1	F020	5/16-18 ESNA Nut		2
13	8607-8	Door Guide	1	F025	10-24 x 3/8 PPHMS		6
14	7607-5	Upper Door Stiffener	1	F027	10-24 x 5/8 PPHMS		8
GHS 7.0 Bushel Catcher Assembly				F029	1/4-20 x 1/2 Hex Bolt		2
15	7503-7	Center Strap (7.0)	1	F049	5/16 SAE Washer		4
16	7503-6	Upper Frame Doubler (7.0)	2	F050	1/4 SAE Washer		6
17	7503-5	Lower Frame Doubler (7.0)	2	F079	A/A66D Aluminum Pop Rivet		14
18	7503-4	Outside Box Strap (7.0)	2	F085	3/16 Rivet Backup Washer		8
19	8608-11	Catcher Door Finger	1	F094	8-32 x 1/2 PTHMS		6
20	8608-4	Center Frame Doubler	1	F129	10-24 x 1/2 PTHMS		14
21	7503-11	Catcher Mount	1	F190	#10 Internal Star Lock Washer		2
22	7620-3	Pivot Bushing (1/2 x 9/16)	4	F195	1/4-20 x 3/4 PPHMS, SS		4
23	7607-7	Bushing	2	F196	1/4-20 x 1 PPHMS, SS		4
24	7608-1	Hinge Plate, LH	1	F230	1/4-20 x 1-1/4 PPHMS, SS		4
25	7607-13	Catcher Door Arm, LH	1	F242	1/4-20 x 7/8 PPHMS, SS		6
26	8155-5	7.0 Gas Spring Cover, LH	1	F275	5/16-18 x 2 Hex Bolt		2
27	5147	Spring Clip	4	F330	3/16D x 21/32L Rivet, SS		4
28	5155-5	Gas Spring	2	F340	Rivet, Aluminum		4
29	5155-13	3/4 Ball Stud	2	F351	Aluminum Pop Rivet		6
30	5523-6	Gas Spring Plate	2	F360	1/4-20 x 3/8 Hex Bolt		4
31	5155-12	5/16 Ball Stud	2	F390	1/4-20 x 7/8 Carriage Bolt		4
32	5155-15	Box Support, Gas Spring	2	F411	3/16 Bulbex Rivet		21
33	7532-1	Handle, Catcher Lift	2	F503	1/4-20 x 1-1/2 PPHMS, SS		1
34	7511-6	Chute Cover	1	F524	3/16 x 3/8 Aluminum Rivet, Black		6
35	5976	Grommet (3/8 x 11/16)	1	* Service Part Only			
36	7557-1	7.0. Wire Harness Channel	1	** This screen can be replaced by P/N 7512-7 Removable Screen (3/4" holes) for improved air flow performance in wet conditions.			

Beginning S/N 125718

Effective Date 11-25-13

Use only genuine Walker® replacement parts.

GHS 7.0 BUSHEL CATCHER ASSEMBLY

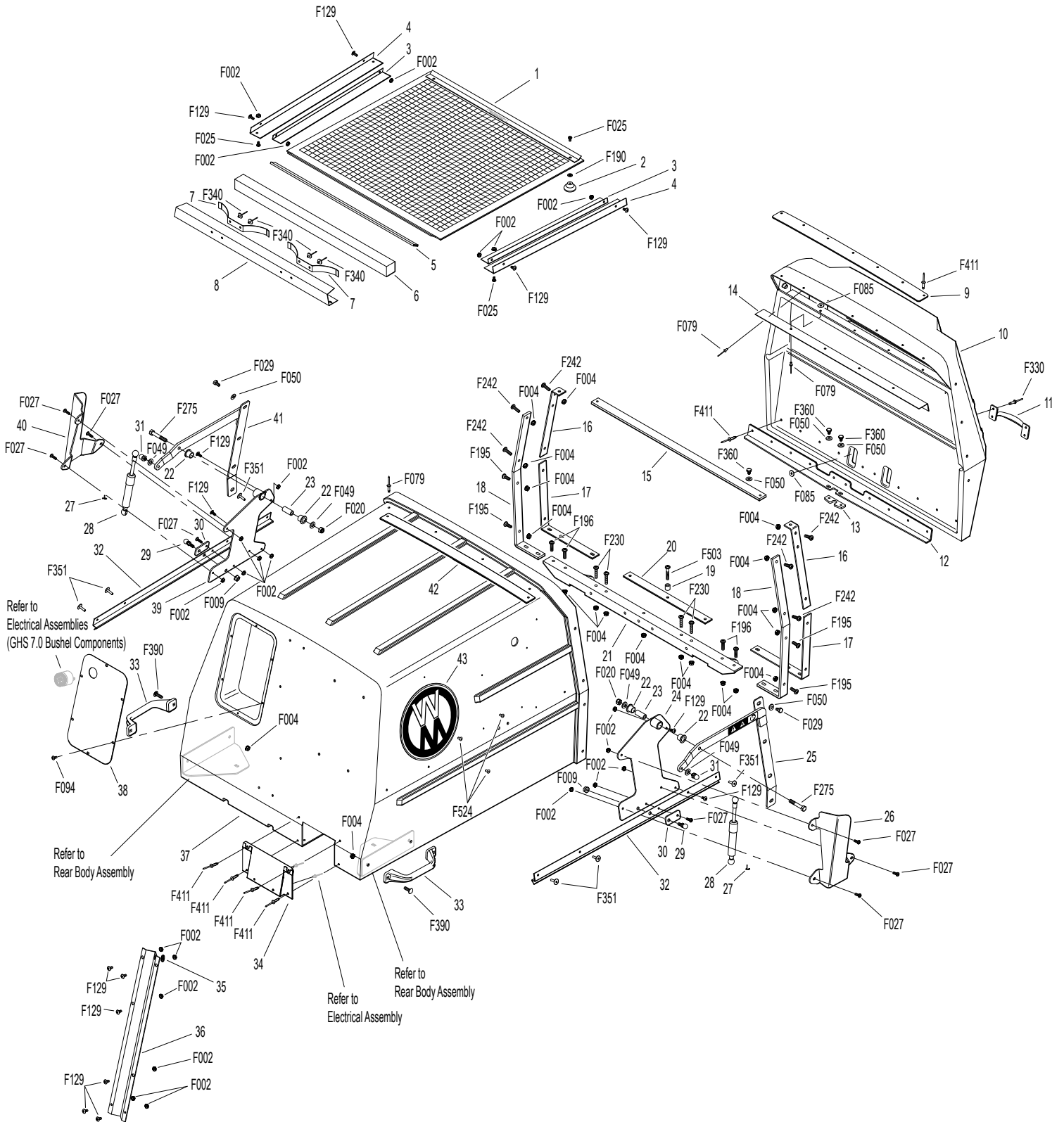

Beginning S/N 125718
 Effective Date 11-25-13
 Use only genuine **Walker**® replacement parts.

ELECTRICAL ASSEMBLY

ITEM NO.	PART NO.	DESCRIPTION	NO. REQ'D	ITEM NO.	PART NO.	DESCRIPTION	NO. REQ'D
Harness Assembly				Fasteners			
1	7941-3	Boot, Circuit Breaker	1	F002		10-24 Keps Nut	8
2	7941-5	Circuit Breaker (7 Amp)	1	F004		1/4-20 Keps Nut	8
3	8990-1	Hourmeter (Global)	1	F009		5/16-18 Whiz Locknut	1
4	5832	Cable Clamp (1/2)	8	F019		1/4-20 ESNA Wing Nut	2
5	5942-11	Delta Hex Nut	1	F025		10-24 x 3/8 PPHMS	2
6	7834-3	Wire Saddle (3 Wires)	1	F026		10-24 x 1/2 PPHMS	5
7	5942-9	Safety Switch (NO), Delta Threaded	1	F031		1/4-20 x 5/8 Hex Bolt	2
8	8960-15	Ignition Switch (with Keys) (Includes Items # 9, 10 & F349)	1	F032		1/4-20 x 3/4 Hex Bolt	4
9	8960-3	Key Set W/Umbrella	1	F050		1/4 SAE Washer	4
10	7854	Plastic Tip, Red	1	F061		1/4 Star Lock Washer	1
11	8536-2	Warning Horn Assembly	1	F079		A/A66D Aluminum Pop Rivet	1
12	8941	Circuit Breaker (30 Amp) Auto Reset / Sealed	1	F093		5/16-18 x 1 Hex Bolt	1
13	5975-3	Cable Tie (50# x 7")	3	F112		5/8 x 1-1/4 x .03 Washer	1
14	6942	Relay Switch (30/40 Amp) NC (Includes Items # 21 & 22)	3	F129		10-24 x 1/2 PTHMS	1
15	5942-8	Safety Switch (NO), Delta Side Mount	2	F203		1/4-20 x 5/8 PPHMS, SS	2
16	7948-6	Time Delay Module (.5 Second Delay)	1	F232		10-32 Keps Nut	2
17	7948-3	Time Delay Harness	1	F349		Washer .835 ID 1.122 OD, SS	1
18	6940-6	Wire Harness	1	F505		6-32 x 7/8 Hex Trim MS, SS	4
19	8012-6	Regulator Adapter Harness	1	F506		6-32 Nylock Nut	2
20	NS	Rectifier	*				
21	6941-7	Relay Mount	*				
22	6941-6	Relay Switch (30/40 Amp)	*				
Battery Assembly				* Service Part Only			
23	8943	Battery Lead Wire (+)	1	NOTE: Refer to ELECTRICAL CONNECTORS , Page 30 for identification of all Electrical Wiring Service Parts.			
24	5975-1	Cable Tie (18# x 3-3/4")	2				
25	5933	Battery Terminal Insul., Red (+)	1				
26	5932	Battery Terminal Insul., Black (-)	1				
27	6923	Battery Cable (-)	1				
28	5844-3	Battery Protector Plate	1				
29	5839	Hook Bolt	2				
30	6390	Battery Pan	1				
31	NS	Battery (12V/300CCA/Dry)	1				

ELECTRICAL ASSEMBLIES (GHS 7.0 BUSHEL COMPONENTS)

ITEM NO.	PART NO.	DESCRIPTION	NO. REQ'D	ITEM NO.	PART NO.	DESCRIPTION	NO. REQ'D
Horn & Harness Channel Assemblies				Fasteners			
1	5536-2	Horn, Full Signal	*	F002		10-24 Keps Nut	4
2	5519-4	Adapter Harness	1	F025		10-24 x 3/8 PPHMS	1
3	5976-2	Grommet (3/16 x 3/4)	1	F037		10-24 x 5/8 PTH Screw	1
4	5975-1	Cable Tie (18# x 3-3/4")	1	F129		10-24 x 1/2 PTHMS	2
Harness & Grass-Pak® Switch Assemblies				F508		4-40 Keps Nut, SS	2
5	8950	9.5 / 10.0 Wire Harness	1	F509		4-40 x 1/2 Hex Head, SS	2
6	5976	Grommet (3/8 x 11/16)	1	* Service Part Only			
7	5833	Cable Clamp (1/4)	2	NOTE: Refer to ELECTRICAL CONNECTORS , Page 30 for identification of all Electrical Wiring Service Parts.			
8	5594-6	Aluminum Shaft & Vane Assembly	1				
9	5592-14	Grass-Pak® Switch Assembly	1				

ELECTRICAL ASSEMBLIES (GHS 7.0 BUSHEL COMPONENTS)

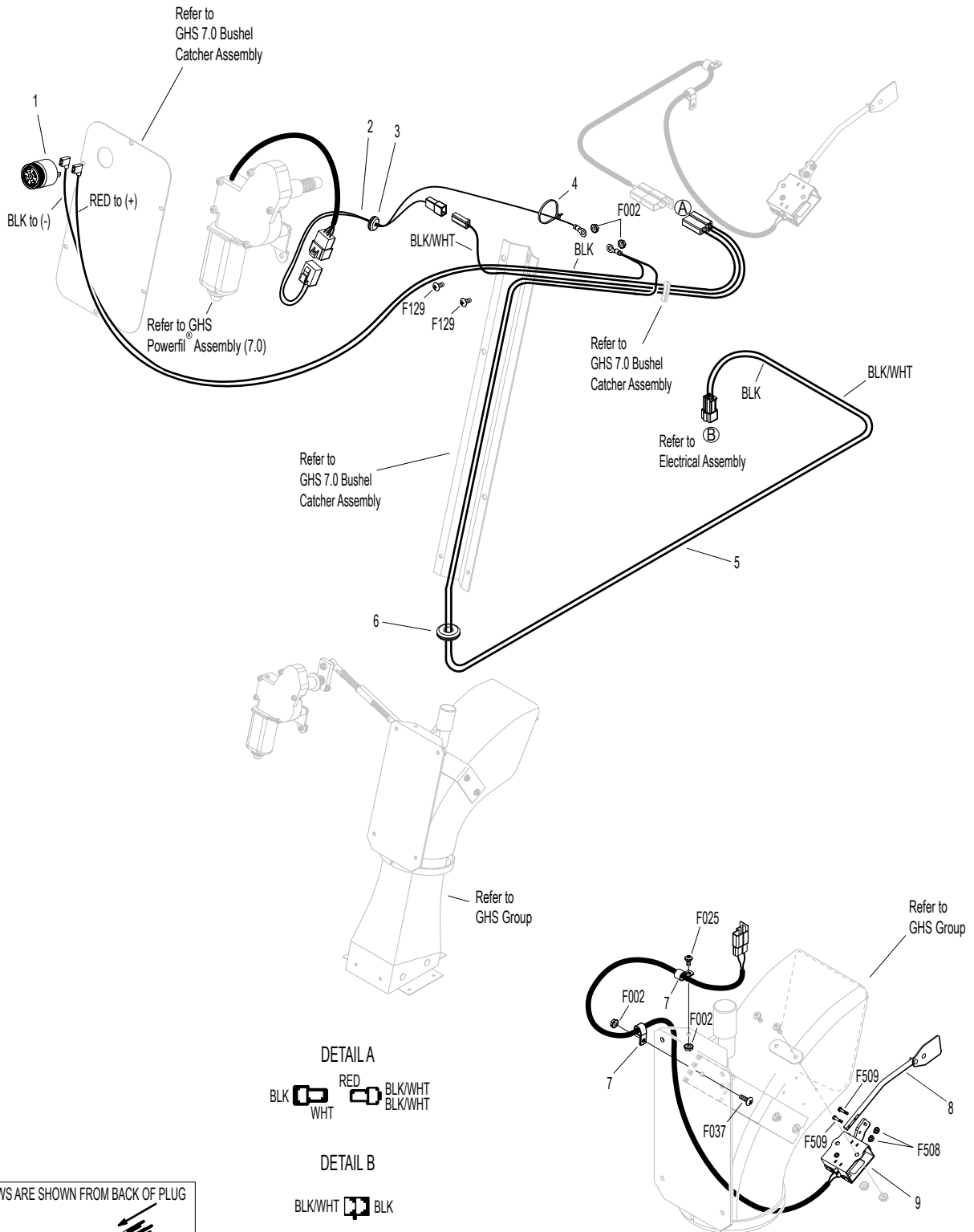

Beginning S/N 125718
 Effective Date 11-25-13
 Use only genuine **Walker**® replacement parts.

ELECTRICAL CONNECTORS

ITEM NO.	PART NO.	DESCRIPTION	NO. REQ'D	ITEM NO.	PART NO.	DESCRIPTION	NO. REQ'D
Electrical Wiring Service Parts				29	7942-1	2-Way Locking Connector, Female	*
1	5996-1	16-14 GA Butt Connector	*	30	7942-2	2-Way Connector, Male	*
2	5996-11	12-10 GA Butt Connector	*	31	7942-3	2-Way Connector, Female	*
3	7942-14	16-14 GA Shrink Connector	*	32	7942-10	2-Way Locking Connector, Male	*
4	7942-13	12-10 GA Shrink Connector	*	33	5940-8	3-Way Connector, Male	*
5	5995-1	Wire Terminal Adapter	*	34	7942-9	3-Way Connector, Male	*
6	5996-4	16-14 GA Bullet Conn., Male	*	35	8944	3-Way Locking Connector, Male	*
7	5996-5	16-14 GA Bullet Conn., Female	*	36	8944-1	3-Way Locking Connector, Female	*
8	5940-4	16-14 GA Spg. Loaded Term., Female	*	37	7942-11	4-Way Connector, Male	*
9	5940-7	Wire Clip, Female	*	38	7942-12	4-Way Connector, Female	*
10	5996	1/4 x 16-14 GA QKS Term., Female	*	39	7942-5	5-Way Connector, Male	*
11	5996-2	3/16 x 22-18 GA QKS Term., Female	*	40	5940-2	5-Way Connector, Male	*
12	7996	16-14 GA QKS Term., Female	*	41	8942-1	5-Way Connector, Female	*
13	5940-5	16-14 GA Spg. Loaded Term., Male	*	42	7942-6	6-Way Connector, Male	*
14	5996-0	1/4 x 22-18 GA QKS Term., Male	*	43	7942-7	6-Way Connector, Male	*
15	5996-18	16-14 GA Ring Term. (#8) Nylon Insulated	*	44	7942-8	8-Way Connector, Male	*
16	7996-1	1/4 x 16-14 GA QKS Term., Male	*	45	8942-2	8-Way Connector, Female	*
17	5996-8	6 GA Ring Lug (5/16)	*	46	8942-3	5-Way Connector, Male	*
18	5996-9	22-18 GA Ring Term., #10	*	47	5940-9	3-Way Connector (M)	*
19	5996-10	16-14 GA Ring Term. (5/16)	*	48	7942-15	6-Way Connector (Female)	*
20	5996-12	12-10 GA Ring Term. (5/16)	*	49	7940-3	Packard Plug (Male)	*
21	5996-13	16-14 GA Ring Term., # 10	*	50	7940-4	Packard Plug (Female)	*
22	5996-15	12-10 GA Ring Term. (1/2)	*	* Service Part Only			
23	5996-16	6 GA Ring Terminal (1/4)	*	NOTE: Not all Electrical Connectors are used with all assemblies.			
24	5996-17	16-14 GA Ring Term. (1/4)	*	NOTE: Refer to ELECTRICAL ASSEMBLIES , Pages 26-29 for locations of Wiring Harness, Electrical Components and of all Electrical Wiring Service Parts.			
25	5996-20	12-10 GA Ring Term. (1/4)	*				
26	5996-21	12-10 GA Ring Term., #10	*				
27	7942-4	Single Connector, Male	*				
28	8942	2-Way Connector, Male	*				

ELECTRICAL CONNECTORS

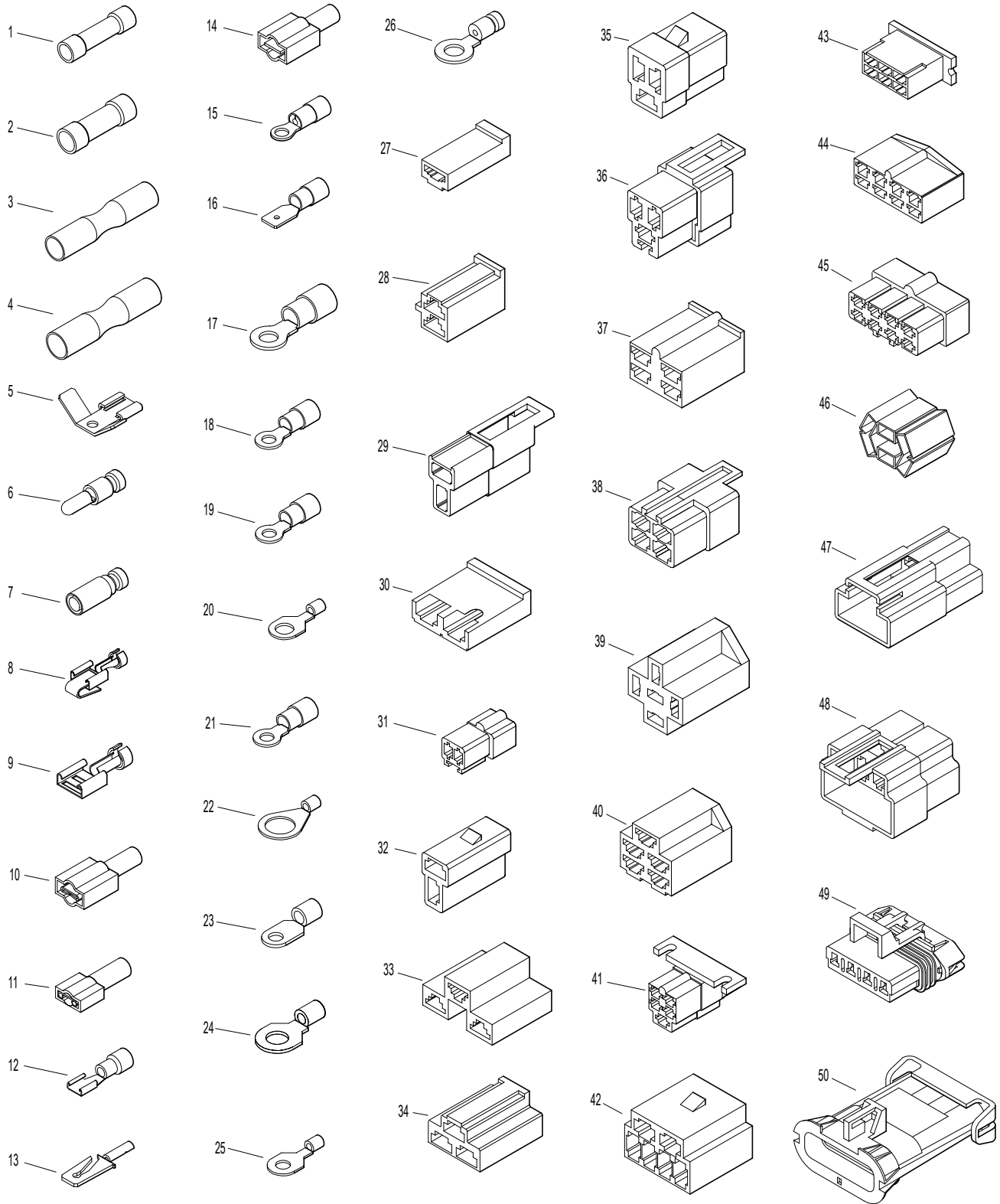

LUBRICATION POINTS

ITEM NO.	LOCATION	LUBRICATION TYPE	NO. PLACES	ITEM NO.	LOCATION	LUBRICATION TYPE	NO. PLACES
Lubrication Points				17	Brake Actuator Rod and Brake Band Pivot Pins (Clevis)	Oil	3
1	Steering Lever Pivot	Grease	4	18	Brake Actuator Pivot	Grease	1
2	Body Hinge Point	Oil	2	19	Choke Control Cable Ends	Oil	2
3	Deck-to-PTO Coupling (Grease Spline Slide Area)	Grease	1	20	Catcher Hinge Point	Oil	2
4	FSC Actuator Rod Pivot Pins	Oil	2	21	Throttle Control Cable Ends	Oil	2
5	FSC Lever Pivot	Grease	1	22	Engine Oil	Oil**	1
6	FSC Lever Fork (Grease Slide Area)	Grease	1	23	Belt Tightener Pivot, Blower Drive	Grease	1
7	(FSC) Friction Body Pivot	Grease	1	24	Belt Tightener Pivot, Ground Drive	Grease	1
8	Deck Support Arm Pivot	Grease	2	25	PTO Gearbox Dipstick	Oil**	1
9	Gear Axle	Oil**	2	26	Hydrostatic Drive	Oil**	2
10	Universal Joint Tube Assembly	Grease*	1	27	Choke Control Pivot	Oil	1
11	Parking Brake Lever	Grease	1	28	Throttle Control Pivot	Oil	1
12	Universal Joint Quick Connect Spline (Grease Slide Area)	Grease	1	* Grease every eight (8) hours.			
13	Belt Tightener Pivot, Jackshaft Drive	Grease	1	** See Operator's Manual for procedure for checking and changing oil in Engine Crankcase, Hydrostatic Transmissions, and Gear Axles.			
14	PTO Clutch Lever Pivot	Grease	1	NOTE: See Model MC19 Operator's Manual (P/N 6000-16) for proper lubrication intervals.			
15	Clutch Actuator Push Rod	Grease	2				
16	Belt Tightener Pivot, PTO Clutch	Grease	1				

LUBRICATION POINTS

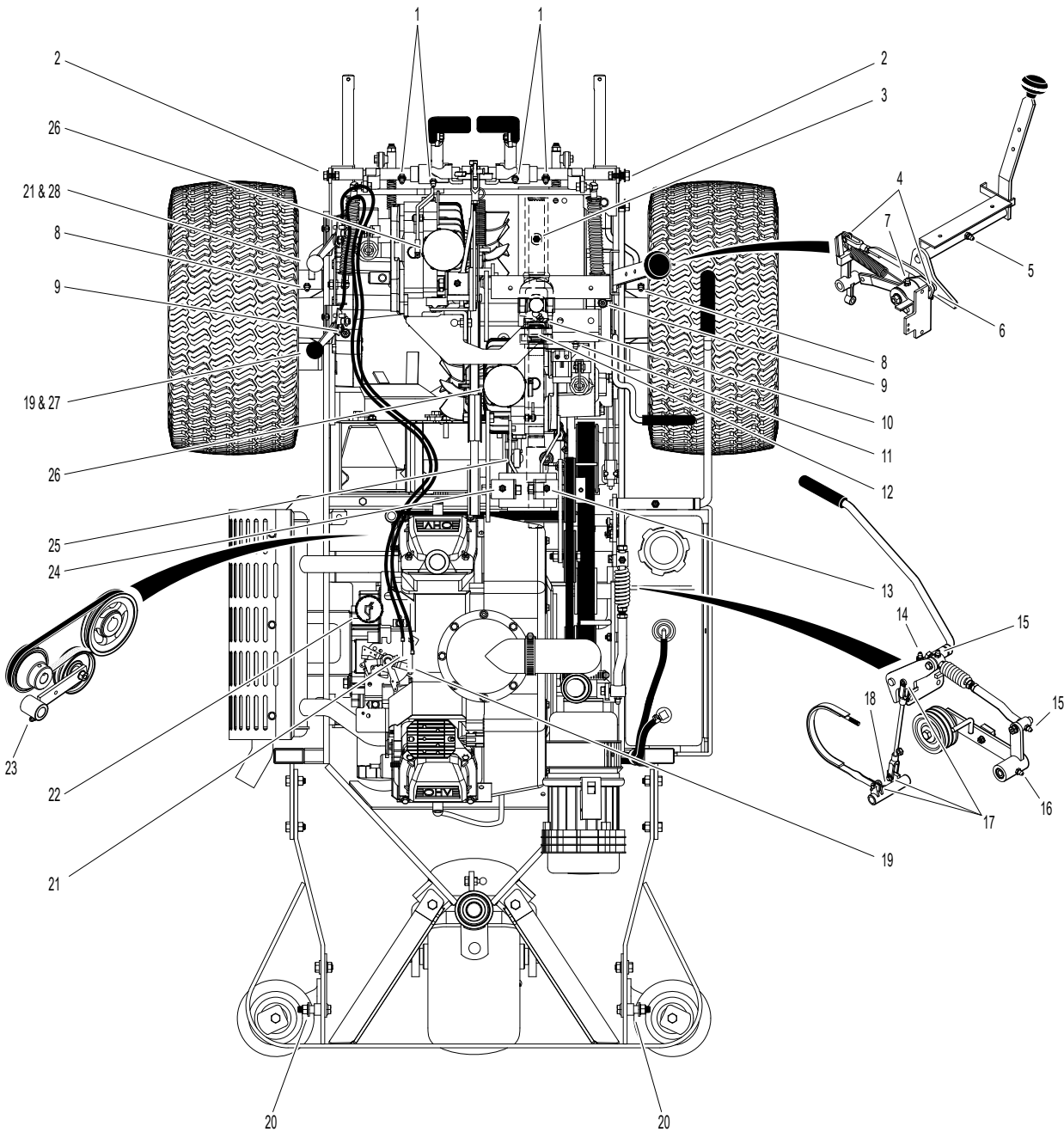

Beginning S/N 125718
Effective Date 11-25-13
Use only genuine **Walker**® replacement parts.

WIRING SCHEMATIC

WALKER MODEL C19 Beginning S/N 2014-125718

IGNITION SWITCH CIRCUITS	
OFF	G + M
START	B + A / S1 + S2
RUN	B + A

S1 = START CIRCUIT
S2 = START/ACCESSORY CIRCUIT
M = MAGNETO GROUND CIRCUIT
B = BATTERY CIRCUIT
A = ACCESSORY CIRCUIT
G = GROUND CIRCUIT

RELAY - A IGNITION RELAY	
OFF	30 + 87A
START	30 + 87A
PTO ON	OPEN

RELAY - B START RELAY	
OFF	OPEN
START	30 + 87
PTO ON	OPEN

RELAY - C DELAY RELAY	
OFF	30 + 87A
START	OPEN
RUN	OPEN

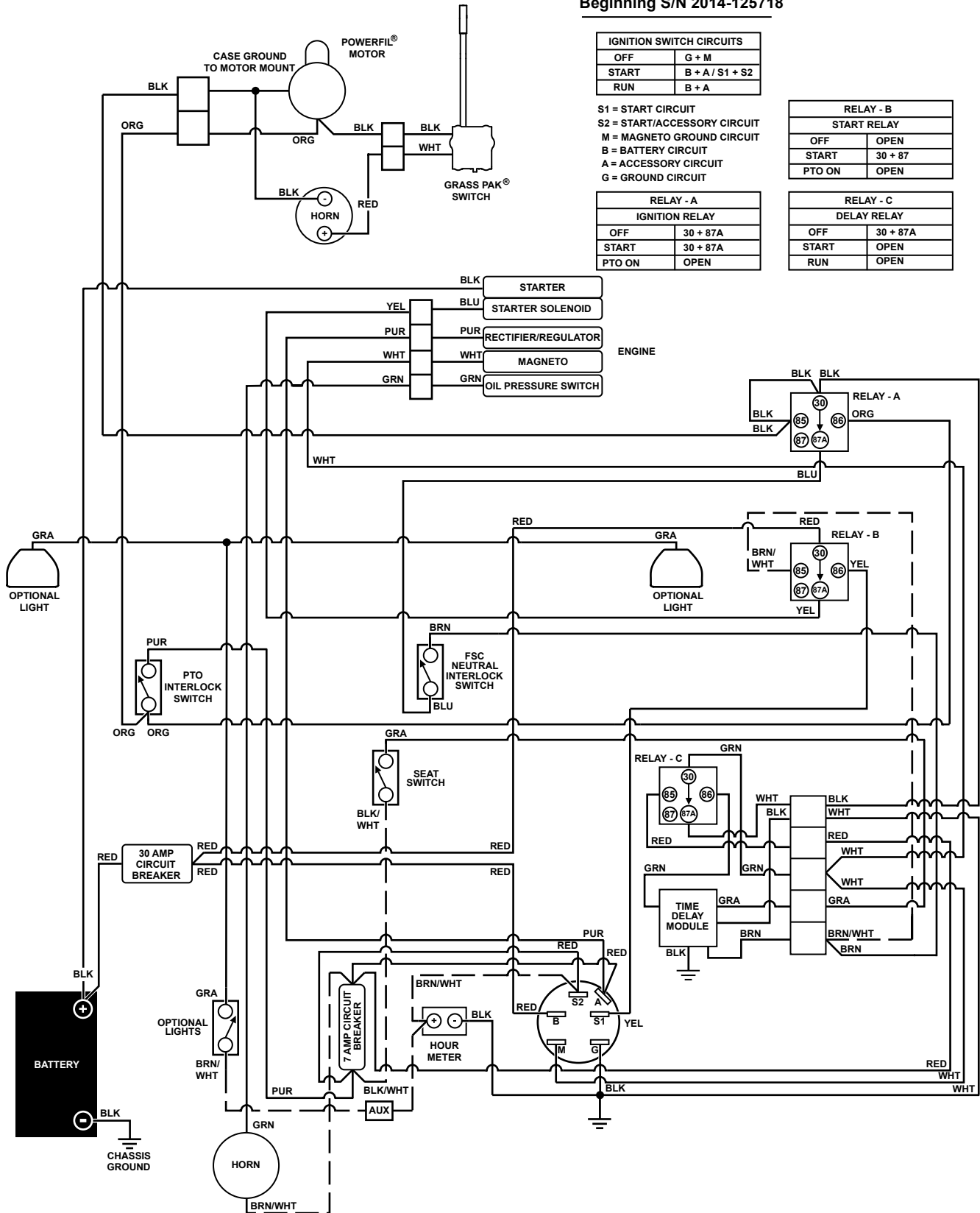

OPERATOR'S NOTES

OPERATOR'S NOTES

LIMITED WARRANTY FOR WALKER COMMERCIAL RIDER MOWER

1. WHAT THIS WARRANTY COVERS, AND FOR HOW LONG:

Walker Manufacturing company will, at its option, repair or replace, without charge, any part covered by this warranty which is found to be defective in material and/or workmanship within one (1) year* after date of sale to the original retail purchaser unless the product is used for rental purposes, in which case this warranty is limited to ninety (90) days. At Walker's request, customer will make the defective part available for inspection by Walker and/or return the defective part to Walker, transportation charges prepaid. All parts and components of the Walker Mower are covered by this warranty **except** the following components which are warranted separately by their respective manufacturers:

Kohler Engine
Battery

The available warranties covering these items are furnished with each mower. Walker does not assume any warranty obligation, liability or modification for these items, which are covered exclusively by the stated warranty of the respective manufacturers noted above.

* Extended warranties are offered for the following powertrain components:

- A three (3) year unlimited hour warranty is offered for the Walker P/N 6200-9 Gear Axle Assembly.
- A three (3) year or 3000 hour (whichever comes first) warranty is offered for Eaton Model 7 Hydrostatic transmissions; covers full cost of replacement up to 1000 hours of use, and after 1000 hours warranty coverage is prorated against 3000 hours.

2. WHAT THIS WARRANTY DOES NOT COVER:

- A. This warranty does not cover defects caused by depreciation or damage caused by normal wear, accidents, improper maintenance, improper use or abuse of the product, alterations, or failure to follow the instructions contained in the Operator's Manual for operation and maintenance.
- B. The customer shall pay any charges for making service calls and/or for transporting the mower to and from the place where the inspection and/or warranty work is performed.

3. HOW TO OBTAIN SERVICE UNDER THIS WARRANTY:

Warranty service can be arranged by contacting the dealer where you purchased the mower or by contacting Walker Manufacturing Company, 5925 East Harmony Road, Ft. Collins, CO 80528. Proof of the date of purchase may be required to verify warranty coverage.

4. WARRANTY LIMITATION:

- A. **THERE IS NO OTHER EXPRESS WARRANTY. ANY WARRANTY THAT MAY BE IMPLIED FROM THIS PURCHASE INCLUDING MERCHANTABILITY AND FITNESS FOR A PARTICULAR PURPOSE IS HEREBY LIMITED TO THE DURATION OF THIS WARRANTY AND TO THE EXTENT PERMITTED BY LAW ANY AND ALL IMPLIED WARRANTIES ARE EXCLUDED.** Some states do not allow limitations on how long an implied warranty lasts, so the above limitations may not apply to you.
- B. **WALKER WILL NOT BE LIABLE FOR ANY INCIDENTAL, CONSEQUENTIAL, OR SPECIAL DAMAGES AND/OR EXPENSES IN CONNECTION WITH THE PURCHASE OR USE OF THE MOWER.** Some states do not allow the exclusion or limitation of incidental or consequential damages, so the above limitation(s) or exclusion(s) may not apply to you.
- C. Only the warranty expressed in this limited warranty shall apply and no dealer, distributor, or individual is authorized to amend, modify, or extend this warranty in any way. Accordingly, additional statements such as dealer advertising or presentations, whether oral or written, do not constitute warranties by Walker, and should not be relied upon.
- D. This warranty gives you specific legal rights, and you may also have other rights which vary from state to state.

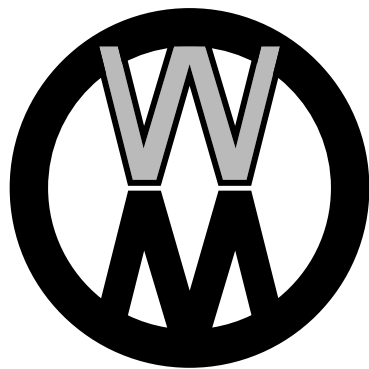

WALKER

WALKER MFG. CO. • 5925 E. HARMONY ROAD, FORT COLLINS, CO 80528 • (970) 221-5614
FORM NO. 112513 PRINTED IN USA www.walkermowers.com ©2014 WALKER MFG. CO