

WALKER

Illustrated Parts Manual

B23i



Beginning S/N: 133534
Effective Date: 04-01-15
P/N 4000-15

KEY TO ABBREVIATIONS USED IN THIS MANUAL

<i>Abbreviation</i>	<i>What it Represents</i>
° (Dimension)	Degrees (Angle)
" (Dimension)	inches
(-)	Negative (Polarity)
(+)	Positive (Polarity)
AT	All-Terrain
CCW	Counter-clockwise
Conn	Connector
CW	Clockwise
D	Diameter
DC	Deck, Collection (number refers to size in inches)
DM	Deck, Mulching (number refers to size in inches)
DR	Deck, Rear Discharge (number refers to size in inches)
DS	Deck, Side Discharge (number refers to size in inches)
DU	Garlock (Bearing)
ESNA (Fastener)	Nylon Insert Locknut
FSC	Forward Speed Control
GA	Gauge
gal	gallon
GHS	Grass Handling System
GR (Fastener)	Grade
HD	Heavy Duty
HP	Horse Power
ID	Identification or Inside Diameter
L	Length
LH	Left Hand (orientated with operator on seat)
LP	Low Profile
mm (Dimension)	millimeters
MS (Fastener)	Machine Screw
NS (as part number)	Item is not sold by Walker Manufacturing
OD	Outside Diameter
oz	ounce
PFH (Fastener)	Phillips Flat Head
P/N	Part Number
PPH (Fastener)	Phillips Pan Head
PTH (Fastener)	Phillips Truss Head
PTO	Power Take-Off
QKS	Quick Slide
qt	quart
RH	Right Hand (orientated with operator on seat)
SAE (Fastener)	Society of Automotive Engineers
SBH (Fastener)	Socket Button Head (Bolt)
SD	Side Discharge
SFH (Fastener)	Slotted Flat Head
SHC (Fastener)	Socket Head Cap
SHL (Fastener)	Shoulder (Bolt)
SM (Fastener)	Sheet Metal (Screw)
S/N	Serial Number
Spg	Spring
SQH (Fastener)	Square Head
SS (Fastener)	Stainless Steel
ST (Fastener)	Self-Tapping (Screw)
Term	Terminal
V	Volts

NOTE: In some instances, combinations of abbreviations may be used (e.g. PPHMS - Phillips Pan Head Machine Screw).

Beginning S/N 133534

Effective Date 04-01-15

Use only genuine **Walker**[®] replacement parts.

ILLUSTRATED PARTS LIST

<i>Section of Tractor Covered</i>	<i>Page</i>	<i>Section of Tractor Covered</i>	<i>Page</i>
Decals		Electrical Components	
Tractor Decals	2	Electrical Assembly	14
Body / Chassis Assemblies		Maintenance	
Body / Chassis Assembly	4	Lubrication Points	16
Tractor Components		Wiring Schematic	18
Main Component Power Transmission	6	Maintenance And Service Record Sheet	19
Engine Group	8	Warranty	
Hydrostatic Ground Drive Assemblies	10	Limited Warranty	21
Steering Control Assemblies	12		

TRACTOR DECALS

ITEM NO.	PART NO.	DESCRIPTION	LOCATION	NO. REQ'D SD
Walker Product and Operation Decals				
1	8600-26	RH Fender	Body, RH Side Near Seat	1
2	9804-1	Axle Lockout	Chassis	2
3	5800-13	Decal, Round (3-3/4")	Rear Body (one on each side)	2
4	5800-7	Decal, Walker (8")	Rear Body	1
5	8600-25	LH Fender	Body, LH Side Near Seat	1
6	8821-3	Decal, B23i	Body	1
7	5856-1	Made In USA	Body	1
Danger Decals Warning Decals Caution Decals				
8	8600-5	Caution, Engine Exhaust	Rear Body	1
9	8600-12	Danger, Engine Exhaust	Engine	1
10	4107-12	Decal, Belt Routing	Rear Body, Underside	1
11	8600-2	Decal, Rotating Components	Flex Coupling Guard (one on each side)	2
Maintenance Decals				
12	5855	Important, Engine Cooling	Engine	1
13	5082-5	Fuel Recommendations	Chassis, LH Side	1
14	6875	PTO Alignment Arrow	Universal Joint Tube Assembly	1
15	5802-3	Engine Service Light	Body	1

NOTE: All parts requiring decals are shipped with decals applied.

TRACTOR DECALS

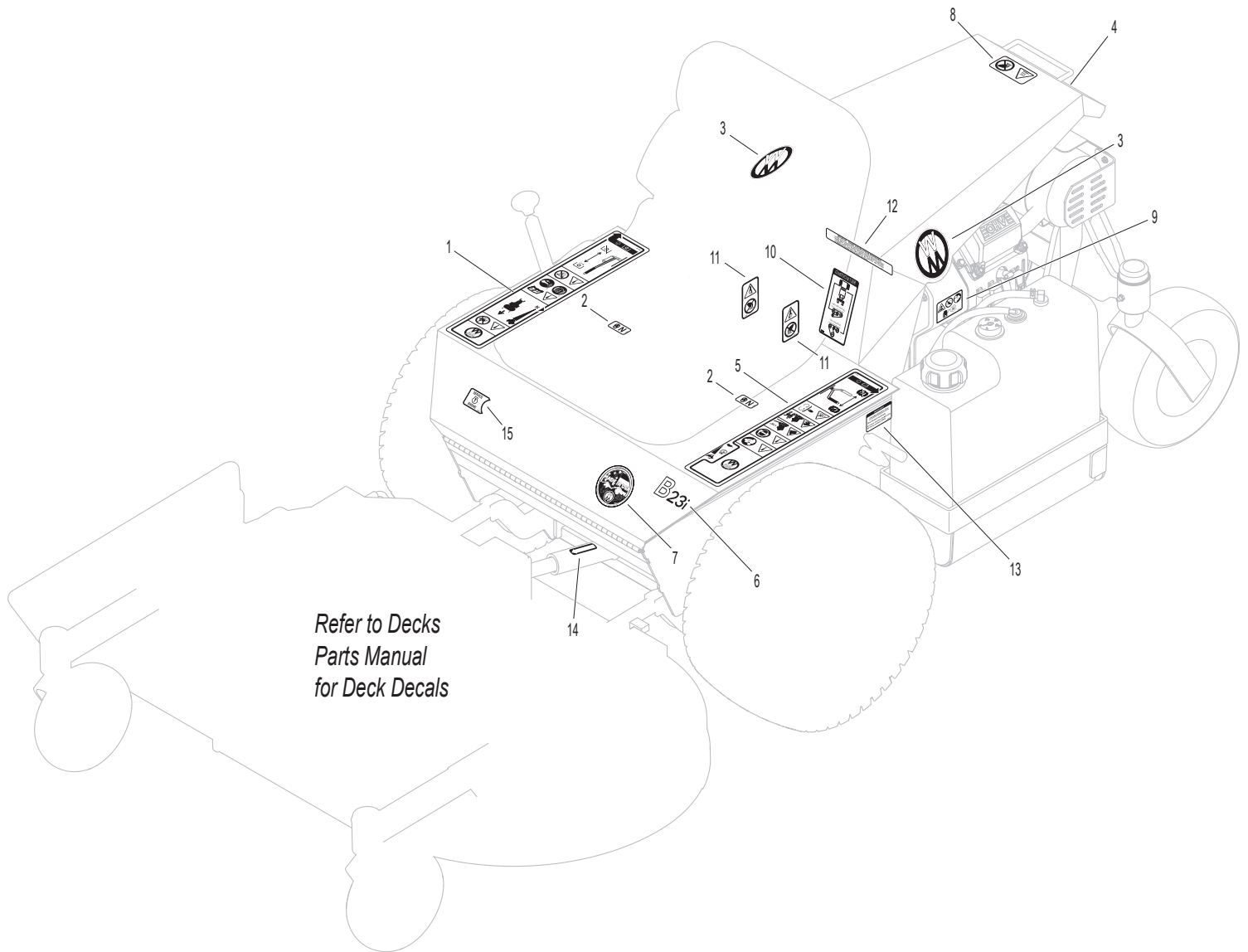

BODY / CHASSIS ASSEMBLY

ITEM NO.	PART NO.	DESCRIPTION	NO. REQ'D	ITEM NO.	PART NO.	DESCRIPTION	NO. REQ'D
Seat Assembly				Deck Support Arm & Hitch Assemblies			
1	5103	Seat	1	45	4301-10	Deck Arm Support Mount	1
2	2505	Leaf Spring	1	46	6840-1	Support Arm Bushing (2-1/16)	2
3	7223-4	Compression Spring	2	47	4431-1	Deck Support Arm, LH (Includes Item # 33)	1
4	7845-1	Rubber Bumper (1.375 x .750)	2	48	5775-2	Hitch Pin (#6)	2
5	7434	Washer (3/8 x 1-1/4 x 1/4)	2	49	4430-1	Deck Support Arm, RH (Includes Item # 33)	1
6	5841-1	Retainer Washer	2	Tilt-Up Latch Assembly**			
7	7440-5	Shock Mount (1-1/4 x 3/4)	2	50	5847	Plastic Tip	1
Body Assembly				51	5744-20	Spring Arm, Tilt-Up Latch	1
8	4102-1	Body Guide, Upper	1	52	5744-10	Spring Pivot Bushing	1
9	4105-5	Rear Body (Includes Item # 10)	1	53	5744-15	Compression Spring (3/8 x 5/8)	1
10	4190-2	Insulation Foam Pad	1	54	5744-13	Mount Angle, LH	1
11	5989-4	Dome Plug (3/8)	2	55	5744-12	Hook, Tilt-Up Latch	1
12	5989-3	Dome Plug (5/16)	2	56	5744-14	Mount Angle, RH	1
13	4100-4	Front Body	1	Fasteners			
14	5845	Rubber Bumper (1.50 x 1.25)	2	F002	10-24 Keps Nut		10
15	5146	10mm Ball Stud	2	F004	1/4-20 Keps Nut		15
16	4145-2	Gas Spring Assembly (Includes Item # 15)	1	F005	1/4-20 ESNA Nut		1
17	5180	Edge Molding / Lever Opening	2	F009	5/16-18 Whiz Locknut		17
18	4504-3	Hinge (19")	1	F013	3/8-16 Whiz Locknut		2
19	5989-55	Dome Plug (1/2)	1	F020	5/16-18 ESNA Nut		1
Chassis Assembly				F025	10-24 x 3/8 PPHMS		8
20	4910-6	Battery Mount	1	F028	10-24 x 3/4 PPHMS		1
21	2046-1	Gas Tank Mount, LH	1	F029	1/4-20 x 1/2 Hex Bolt		4
22	4215-10	Shock Mount / Body Lift Arm	1	F034	5/16-18 x 3/4 Hex Bolt		9
23	4301-8	Chassis Frame, MB23i	1	F038	3/8-16 x 1 Hex Bolt		1
24	4102-2	Body Guide, Lower	1	F051	3/8 SAE Washer		1
25	7222	Extension Spring (1/4 x 3)	1	F093	5/16-18 x 1 Hex Bolt		2
26	7854	Plastic Tip, Red	1	F116	1/4-20 x 1-1/4 Hex Bolt		1
27	7383-1	Body Latch Hook	1	F183	.312 x .700 x .074 Washer		2
Spread Tail Wheel Assembly				F200	7/16-20 x 3 Grade 8 Bolt		2
28	4401-4	Washer (1-3/4 x 3/8 x 1/4 Thk)	1	F218	7/16 Split Lock Washer		4
29	4301-2	Fiberglide Thrust Washer	2	F219	7/16-14 x 1-1/4 Hex Bolt		4
30	4301-3	Fiberglide Bearing	2	F227	3/8 x 1-1/4 x 1/8 Washer		2
31	5830-3	Grease Fitting (45 Deg.)	1	F246	1/4-20 x 1/2 PTHMS		8
32	4301-1	Tail Wheel Pivot (Includes Items # 30, 31 & 33)	1	F257	3/8 x 1-11/16 Shoulder Bolt		2
33	5830	Grease Fitting	4	F278	3/8 Split Lock Washer		1
34	8769-8	Dust Cap, Deck Caster	2	F341	Coil Roll Pin (7/64 x 9/16)		1
35	8769-6	Bearing Cone (1" ID)	4	F342	5/16 Conical Washer		2
36	8769-5	Bearing Cup (2 x 1-5/8)	4	F344	3/4-16 Slotted Hex Nut		2
37	8769-7	Seal	2	F347	3/4 SAE Washer		2
38	8765-11	Caster Wheel Fork	2	F348	1/8 x 1-1/2 Cotter Pin		2
39	8767	Axle, Caster Wheel (5-1/8)	2	F381	1/4-20 Hex Nut		1
40	8037-1	Seal, Outer (1-3/4 x 1-1/8)	2	F388	3/8-16 x 2-1/2 Hex Bolt		2
41	8037	Bearing Cone (3/4 ID)	4	F430	7/16-20 ESNA Nut		2
42	8768	Caster Wheel, Pneumatic (11 x 4.00-5)	2	F475	1/4-20 x 1 PFH Screw		1
	8768-3	Tire, Pneumatic (11 x 4.00-5)	*	F477	1/4-20 x 5/8 Carriage Bolt		2
	8768-5	Caster Wheel (5 x 3)	*	* Service Part Only			
43	8768-2	Seal, Reverse Lip	2	** Complete Tilt-Up Latch Assembly Kit available by ordering kit # 5747.			
44	8766	Axle Nut (3/4-16)	2				

Beginning S/N 133534

Effective Date 04-01-15

Use only genuine Walker® replacement parts.

MAIN COMPONENT POWER TRANSMISSION

ITEM NO.	PART NO.	DESCRIPTION	NO. REQ'D	ITEM NO.	PART NO.	DESCRIPTION	NO. REQ'D
PTO Drive Assembly				Fasteners			
1	4850	Handle Grip, Black	1	F004	1/4-20 Keps Nut		8
2	2358-12	Fiberglide Bushing	1	F005	1/4-20 ESNA Nut		2
3	7201-2	Fiberglide Bearing 1/2"	1	F008	5/16-24 Keps Nut		1
4	4358-13	Clutch Lever (Includes Items # 1 & 5)	1	F009	5/16-18 Whiz Locknut		18
5	5830	Grease Fitting	4	F010	5/16-24 ESNA Nut		1
6	5103-2	Pivot Bushing (5/16 ID)	2	F012	3/8-16 Keps Nut		3
7	2358-6	5/16-18 x 1-3/4 Stud	2	F013	3/8-16 Whiz Locknut		1
8	2358-8	Adjustor Brace	1	F014	3/8-16 ESNA Nut		1
9	4358-12	Clutch Pivot Plate	1	F024	5/16-24 Jam Nut		1
10	5214-13	Ball Joint (3/8)	2	F029	1/4-20 x 1/2 Hex Bolt		1
11	7775-6	Wire Lock Pin (2-1/2")	3	F031	1/4-20 x 5/8 Hex Bolt		12
12	4302	Right Hand Shoe	1	F034	5/16-18 x 3/4 Hex Bolt		8
13	4302-5	Upper Shoe, LH	1	F035	5/16-18 x 1-1/4 Hex Bolt		4
14	4302-1	Left Hand Shoe	1	F040	3/8-16 x 1-1/2 Hex Bolt		1
15	2302-6	Shoe Mount, LH	1	F041	3/8-16 x 1-3/4 Hex Bolt		2
16	4302-2	Shoe Mount	2	F051	3/8 SAE Washer		2
17	4325-12	Idler Mount	1	F058	1/4 Wave Spring Washer		6
18	4236-3	PTO Drive Pulley (5/AA)	1	F060	AN960516 Washer		2
19	4302-6	PTO Shoe	1	F061	1/4 Star Lock Washer		1
20	7775-7	Wire Lock Pin (3")	1	F069	3/32 x 1/2 Cotter Pin		2
21	7275-9	Quick Coupler Installation Tool	1	F093	5/16-18 x 1 Hex Bolt		2
22	7275-16	Universal Joint Tube Assembly / Spline	1	F120	AN960416 Washer		8
23	4274-12	PTO Drive Shaft Assembly / Spline	1	F149	1/4 x 1/4 x 1-1/2 Key		1
24	4358-7	Clutch / Pivot Stop	1	F153	3/16 x 3/16 x 1-1/4 Key		1
25	7201-3	Fiberglide Bearing	2	F171	5/16-18 x 3/8 Set Screw		2
26	7201-8	Inner Race (4")	1	F178	1/4 x 1 Fender Washer		1
27	4359	Clutch Engagement (Includes Item # 5)	1	F183	.312 x .700 x .074 Washer		2
28	7523-3	Clevis Pin W/Hole (1/4 x 1/2)	1	F209	.765 ID x 1.312 OD x .032 Washer		1
29	4359-2	Brake Band Link / Rear	1	F211	1/4-20 x 7/8 Hex Bolt		2
30	4304	Brake Band	1	F290	3/8-16 x 5 Hex Bolt		1
31	4359-1	Brake Band Link / Front	1	F298	3/8-24 Jam Nut		2
32	7523-2	Clevis Pin W/Hole (1/4 x 5/8)	1	F325	1/4-20 x 3 Hex Bolt		1
33	4411-3	Drive Shaft	1	F350	1/4-20 LP Nylock		6
34	4245-1	Idler Pulley (4/Flat)	2	F381	1/4-20 Hex Nut		1
35	4230-1	Engine/PTO Belt / Matched Set	1	F435	1/4 x 1/4 x 1-1/4 Key		1
36	4236-4	Idler Pulley (4/AA)	1	F449	Washer 1/2 x 1-5/8 x 1/4		1
37	5214-2	Ball Joint (5/16-24) (Nylon Lined)	1	F451	1/2-20 Nylon Locknut		1
38	5226-1	Spring (3/4 x 2-1/2)	1	F484	Washer .380 ID x 1.0 OD x .120		3
39	7380	Knuckle Joint	1				
40	4303-7	Clutch Actuator Bolt (5/16)	1				
41	7377	Plastic Washer (1 x .438 x .025)	2				
42	7378	Pivot Bearing (7/16 x 9/16)	1				
43	4325-1	Clutch Arm	1				
44	5221	Extension Spring (3/4 x 4)	1				
45	2358-11	Clutch Actuator	1				

Beginning S/N 133534

Effective Date 04-01-15

Use only genuine **Walker**® replacement parts.

MAIN COMPONENT POWER TRANSMISSION

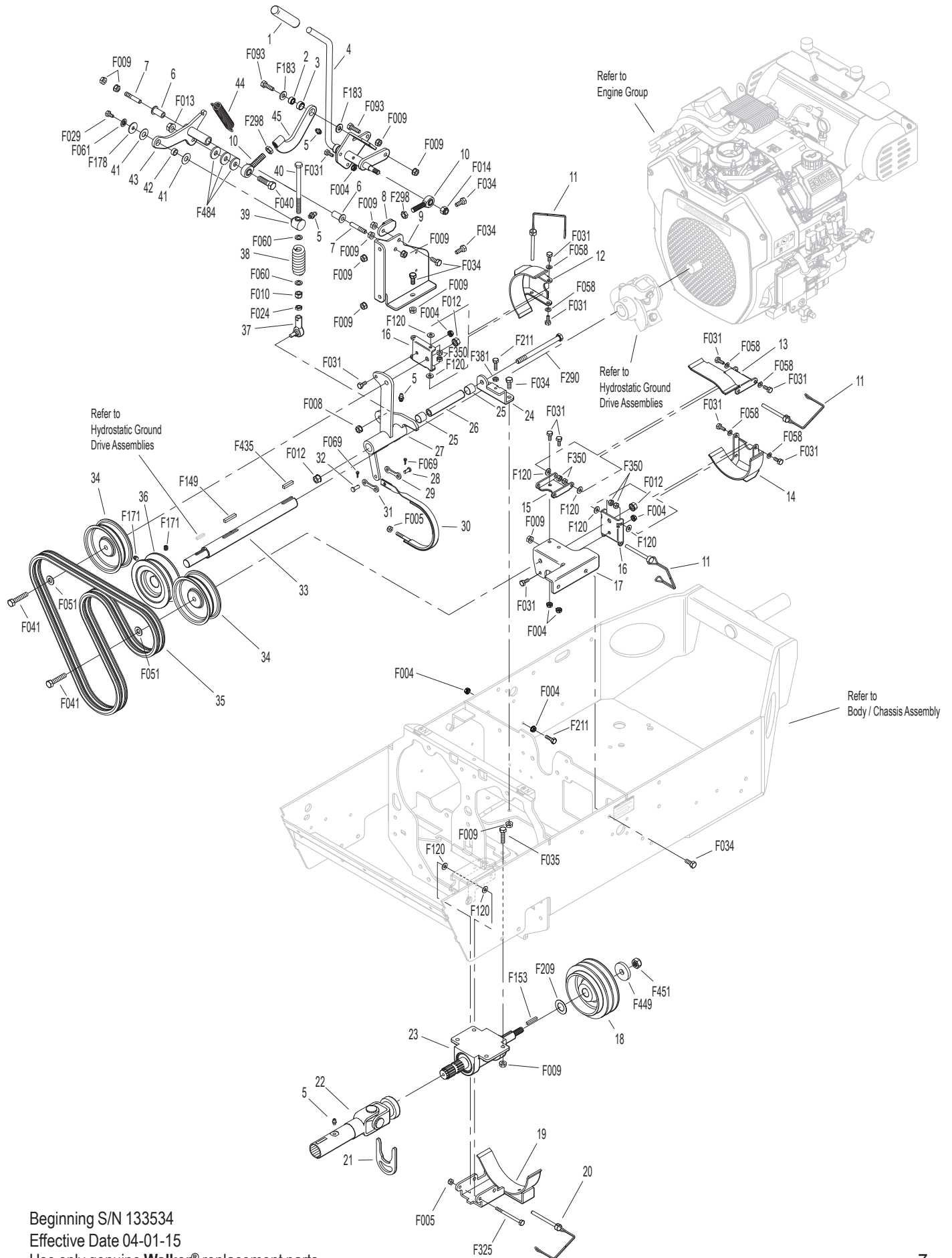

Beginning S/N 133534
 Effective Date 04-01-15
 Use only genuine **Walker**® replacement parts.

ENGINE GROUP

ITEM NO.	PART NO.	DESCRIPTION	NO. REQ'D	ITEM NO.	PART NO.	DESCRIPTION	NO. REQ'D
Remote Oil Cooler Assembly				Throttle Assembly			
1	NS	Oil Cooler Hose (Kohler 24326127)	2	37	8123-3	Insultherm (3/8 x 10)	1
2	NS	Clamp (Kohler 25 237 02-S)	4	38	4108-3	Control Cable (64")	1
3	NS	Oil Cooler (Kohler 24 594 12-S)	1	39	5975-3	Cable Tie (50# x 7")	2
4	8016-8	Oil Cooler / Regulator Mount	1	40	7108	Control Assembly	1
					4108-2	Throttle Control and Cable Assembly (Includes Item # 41)	*
				41	5108-5	Throttle Control Knob, Red	1
Engine Assembly				42	5108-1	Control Lever, Throttle	1
5	4104-3	Body Support	1	43	5108-8	Control Bracket	1
6	4845	Rubber Bumper (1.0 x .625)	2	44	5108-10	Friction Washer (.125)	1
7	NS	Bolt (Kohler)	2	45	5108-7	Control Lock Tab	1
8	2013-4	Shield Side	2	46	5172	Bearing, Delrin (.255 ID x .379 OD x .250)	1
9	2013-3	Muffler Heat Shield	1	Fasteners			
10	NS	Muffler	1	F002	10-24 Keps Nut		7
11	NS	Oxygen Sensor (Kohler 25 418 07-S)	1	F004	1/4-20 Keps Nut		2
12	NS	23 HP Engine (Kohler)	1	F005	1/4-20 ESNA Nut		1
13	4010-1	Drain Valve 3/8-18 NPTF	1	F009	5/16-18 Whiz Locknut		4
				F025	10-24 x 3/8 PPHMS		6
				F029	1/4-20 x 1/2 Hex Bolt		2
				F034	5/16-18 x 3/4 Hex Bolt		2
				F050	1/4 SAE Washer		2
				F164	10-24 x 1/4 x 3/8 SHL Bolt		1
				F175	1/2 Split Lock Washer		4
				F184	1/4-20 x 1/2 Hex Bolt, SS		2
				F185	1/4 Internal Star Lock Washer, SS		2
				F201	1/4 Belleville Spring Washer		2
				F439	1/2-13 x 1-3/4 Hex Bolt		4
				F482	8-32 Nylock Nut		2
				F483	8-32 x 3/4 PPHMS		2
Precleaner Assembly							
14	6029	Hose Clamp (1-3/4 to 2-1/4)	2				
15	6087-4	Air Intake Hose	1				
16	5091-0	1/8 Pipe Thread Male W/Barb	1				
17	4090	Air Cleaner Assembly (90 Degree 2") (Includes Items # 17 & 20-22)	1				
18	5091-6	Air Flow Indicator W/Bracket	1				
19	M258	Vacuum Hose (13")	1**				
20	NS	Air Cleaner Band	1				
21	5090-5	Safety Filter Insert	1				
22	5090-4	Air Cleaner Cartridge	1				
Fuel Tank Assembly							
23	M246	Fuel Line (1/4 x 37")	1**				
24	5879-3	Hose Clamp (1/2)	3				
25	NS	Fuel Filter (Kohler)	1				
26	M246	Fuel Line (1/4 x 5")	1**				
27	5083-8	Tank Tube (13")	1				
28	5083-1	Bushing, Rubber (Fits 5083)	1				
29	8043-8	Roll Over Valve	1				
30	M113	Fuel Line (3/16 x 34")	1**				
31	8055-2	Fuel Tank Gauge	1				
32	5977-7	Roll Over Grommet (.900 x 1-1/2)	1				
33	8055-1	Fuel Tank, 4.7 Gallon (Black) (Includes Items # 27-29, 31, 32, 34 & 35)	1				
34	5086-7	Hose (1/4 x 6)	1				
35	5020-2	Fuel Filter, In Tank	1				
36	5082-4	2-1/4 Ratchet Fuel Cap (EPA)	1				

* Service Part Only

**** Required hose specifications:**

M113 - 3/16" ID fuel/oil/vapor hose (Gates 4219-0093 or equivalent)
M246 - 1/4" ID low permeation (<15g/m²/day) fuel hose (Parker 38904 or equivalent)
M258 - 7/64" ID automotive vacuum hose

ENGINE GROUP

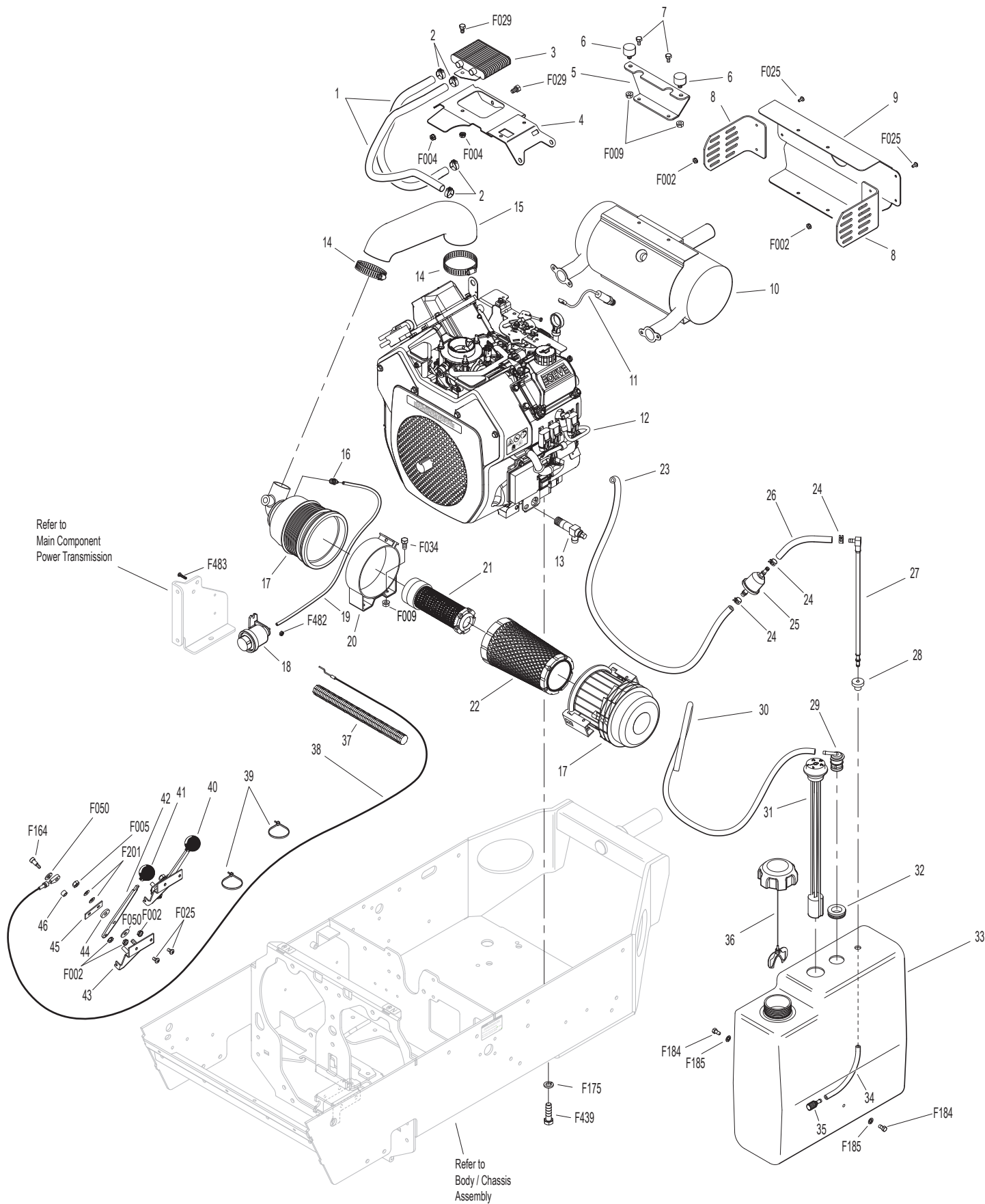

Beginning S/N 133534
 Effective Date 04-01-15
 Use only genuine **Walker®** replacement parts.

HYDROSTATIC GROUND DRIVE ASSEMBLIES

ITEM NO.	PART NO.	DESCRIPTION	NO. REQ'D	ITEM NO.	PART NO.	DESCRIPTION	NO. REQ'D
Ground Drive Assemblies				39	4401-6	Parking Brake Mount	1
1	4025-8	Reservoir Mount	1	40	4401-7	Parking Brake Pivot	1
2	4010-15	Flex Coupling Guard	1	41	4407-3	Parking Brake Actuator	1
3	2351-3	Flex Coupler Half (Includes Items # F171 & F435)	2	42	5665-1	Compression Spring (2-1/2)	2
4	2351-1	Rubber Iso Coupler	3	43	4407	Parking Brake Link	1
5	4349-11	Flanged Bearing (1") (Reversed Bearing) (Prior to S/N 137381)	1	44	5222	Extension Spring (1/2 x 3-1/4)	1
	4349-12	Flanged Bearing (1") (Beginning S/N 137381)	1	45	5463	Steering Lever Actuator	2
6	4025-10	Hose Channel	1	Wheel Assembly			
7	5975-3	Cable Tie (50# x 7")	4	46	5075-1	LP Wheel & Tire Assembly (18 x 8.50-10)	2
8	4026-9	Pulley (52364)	2		5075-2	LP Tire (18 x 8.50-10)	*
9	4245	Idler Pulley (3/A)	1		5075-5	LP Wheel (10 x 7)	*
10	4240-1	Drive Pulley (Includes Items # F067 & F171)	1		5033-6	Wheel & Tire (18 x 7.00-8)	**
11	4349-10	Flanged Bearing (3/4") (Prior to S/N 134794)	1		5030-6	Standard Tire (18 x 7.00-8)	*
	6349-2	Flanged Bearing (3/4") (Beginning S/N 134794)	1		5031-2	Standard Wheel (8 x 5.00-5)	*
12	4230-2	Ground Drive Belt	1		5030-4	Tire Tube (18 x 8.50-8)	*
13	5841	Retainer Washer (3/8 x 1-1/4)	1	Fasteners			
14	7201-3	Fiberglide Bearing	2		F004	1/4-20 Keps Nut	13
15	7201-5	Inner Race (2-1/4)	1		F009	5/16-18 Whiz Locknut	8
16	4325-13	Idler Arm (Includes Items # 14 & 18)	1		F012	3/8-16 Keps Nut	2
17	7364-2	Torsion Spring	1		F013	3/8-16 Whiz Locknut	6
18	5830-3	Grease Fitting (45 Deg.)	2		F015	1/2-20 Wheel Lug Nut	8
19	9430-1	Spacer Tube	4		F020	5/16-18 ESNA Nut	5
20	4025-11	Hydro-Gear ZT3100, LH	1		F029	1/4-20 x 1/2 Hex Bolt	8
21	4026-11	Hydro-Gear ZT3100, RH	1		F031	1/4-20 x 5/8 Hex Bolt	5
22	4407-4	Bow Tie Cotter Pin	3		F034	5/16-18 x 3/4 Hex Bolt	10
23	2028-5	Lockout Arm, LH	1		F038	3/8-16 x 1 Hex Bolt	4
24	2028-6	Lockout Arm, RH	1		F039	3/8-16 x 1-1/4 Hex Bolt	4
25	2025-17	Straight Thread Hose Fitting	2		F040	3/8-16 x 1-1/2 Hex Bolt	1
26	5879-4	Hose Clamp (7/16)	2		F042	3/8-16 x 2-1/4 Hex Bolt	2
27	8015	Hose (1/4 x 14-1/2)	2		F043	3/8-16 x 3 Hex Bolt	1
28	5879-3	Hose Clamp (1/2)	2		F050	1/4 SAE Washer	2
29	4025-3	Elbow (1/4 x 1/2)	2		F051	3/8 SAE Washer	1
30	5879-8	Hose Clamp (13/16)	4		F052	5/16 Ext. Star Lock Washer	6
31	5087-1	Hose (1/2 x 1-3/4)	2		F067	3/16 x 3/16 x 1 Key	1
32	2025-1	Oil Expansion Reservoir (71327)	1		F069	3/32 x 1/2 Cotter Pin	2
Parking Brake Assembly					F171	5/16-18 x 3/8 Set Screw	5
33	4406	Parking Brake Lever (Includes Items # 18 & 34)	1		F182	1/4 x 5/8 x 1/8 Washer	4
34	7406-1	Handle Grip, Red	1		F183	.312 x .700 x .074 Washer	11
35	8655-4	Clevis Pin (5/16 x 3/4)	2		F336	3/8-16 Jam Nut	1
36	4406-12	Brake Actuator Pull	1		F350	1/4-20 LP Nylock	2
37	2280	Clevis (3/8)	1		F369	5/16-18 x 4-1/2 Hex Bolt	2
38	2406-4	Clevis Pin (5/16 x 1-1/8)	1		F434	5/16-18 x 3-1/2 Hex Bolt	4
					F435	1/4 x 1/4 x 1-1/4 Key	2
				*	Service Part Only		
				**	May be ordered as a factory-installed option or for dealer installation. Narrow Drive Tires are used when installing a 36" Deck. Contact your Walker dealer.		

Beginning S/N 133534

Effective Date 04-01-15

Use only genuine **Walker**® replacement parts.

HYDROSTATIC GROUND DRIVE ASSEMBLIES

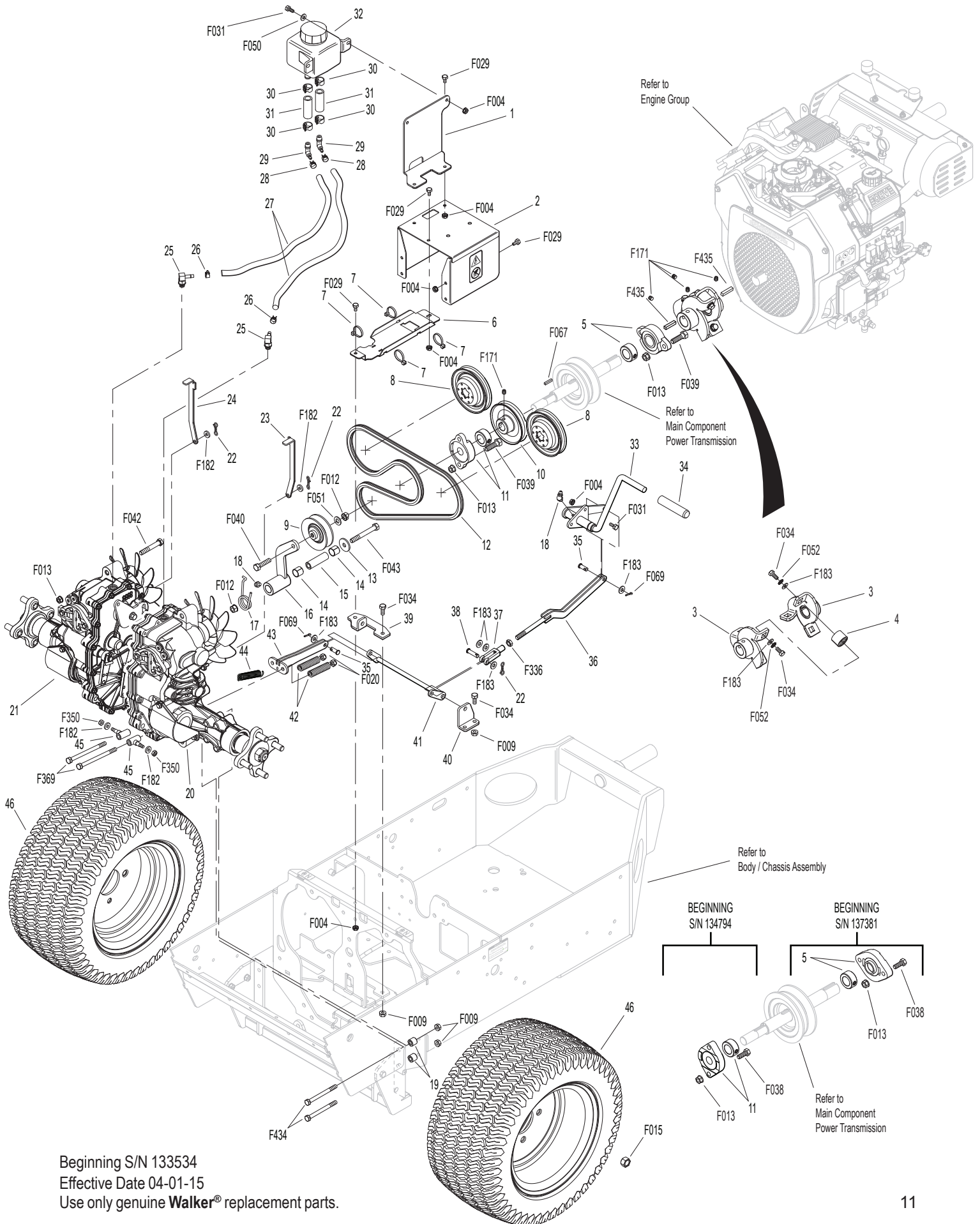

Beginning S/N 133534
 Effective Date 04-01-15
 Use only genuine **Walker®** replacement parts.

STEERING CONTROL ASSEMBLIES

ITEM NO.	PART NO.	DESCRIPTION	NO. REQ'D	ITEM NO.	PART NO.	DESCRIPTION	NO. REQ'D
Steering Lever & FSC Assemblies				Fasteners			
1	5862	FSC Knob	1	F004	1/4-20 Keps Nut		2
2	4170	FSC Lever Assembly (Includes Item # 4)	*	F005	1/4-20 ESNA Nut		2
3	2170-1	Step Washer	1	F008	5/16-24 Keps Nut		2
4	5830	Grease Fitting	1	F009	5/16-18 Whiz Locknut		6
5	5214-5	Ball Joint (5/16-24/LH) W/O Stud	1	F010	5/16-24 ESNA Nut		2
6	4173	Control Rod (5-3/8)	1	F024	5/16-24 Jam Nut		3
7	5214-4	Ball Joint (5/16-24) W/O Stud	1	F029	1/4-20 x 1/2 Hex Bolt		2
8	4219	Extension Spring (3/4 x 6-1/2)	1	F035	5/16-18 x 1-1/4 Hex Bolt		1
9	4451-9	FSC Friction Actuator	1	F044	5/16-24 x 3/4 Hex Bolt		2
10	5830-3	Grease Fitting (45 Degree)	2	F059	3/8 Wave Spring Washer		1
11	5146	10mm Ball Stud	4	F093	5/16-18 x 1 Hex Bolt		2
12	4199-2	Steering Lever Dampener Assembly	2	F146	1/4-20 Jam Nut		2
13	2463	Actuator Washer	2	F167	5/16-18 Hex Nut		1
14	7201-2	Fiberglide Bearing (1/2")	2	F183	.312 x .700 x .074 Washer		6
15	5463-3	Steering Lever Actuator	2	F188	1/4-20 Self-Locking Nut		4
16	5665-1	Compression Spring (2-1/2)	2	F192	3/8-24 Self-Locking Nut		1
17	4213-2	Control Rod (6-3/4)	2	F198	.250 x .625 x .040 Washer, SS		2
18	5214-2	Ball Joint (5/16-24) (Nylon Lined)	2	F211	1/4-20 x 7/8 Hex Bolt		1
19	2212-3	Seal Retainer	2	F312	3/8 x 3/8 Shoulder Bolt		1
20	2212	Transmission Control Arm Stop	2	F345	1/4-20 x .770 Knurled Bolt		4
21	6212-2	Transmission Control Arm, RH	1	F373	5/16-24 Hex Nut, LH		1
22	6212-3	Transmission Control Arm, LH	1	F385	1/4 x 1-1/4 Roll Pin		1
23	4451-1	Steering Pivot Shaft W/Stop	1	F386	5/16-18 x 1-1/2 x 3/8 Shoulder Bolt		1
24	9704-3	Pivot Rod Bushing / Plastic	2	F391	1/4-20 x 1/2 Set Screw, SS		2
25	4142-2	FSC Friction Washer (1-1/2 x 1-1/32 x 1/16)	1	F407	Belleville Washer 3/8 x 1.187, SS		1
26	5141	FSC Friction Washer (1-1/2 x 3/8 x 1/16)	1	F427	5/16-18 Flange Nut		1
27	4142-1	FSC Cam	1	* Service Part Only			
28	7201-3	Fiberglide Bearing	4				
29	4452-6	Steering Pivot (1/4-20 x 1-5/8)	2				
30	6451-1	Speed Control Actuator, LH (Includes Items # 10 & 28)	1				
31	5222	Extension Spring (1/2 x 3-1/4)	2				
32	5450	D-Clip	2				
33	4452-4	Steering Lever Tube W/Tab	2				
34	5453-10	Steering Lever Handle / Adjustable (Includes Items # 35 & F345)	2				
35	5850-2	Handle Grip, Foam (5-1/2)	2				
36	6451-2	Speed Control Actuator, RH (Includes Items # 10 & 28)	1				

ELECTRICAL ASSEMBLY

ITEM NO.	PART NO.	DESCRIPTION	NO. REQ'D	ITEM NO.	PART NO.	DESCRIPTION	NO. REQ'D
Electrical Assembly				Fasteners			
1	5942-11	Delta Hex Nut	1	F002		10-24 Keps Nut	5
2	5942-9	Safety Switch (NO), Delta Threaded	1	F003		1/4-28 Hex Nut	1
3	7834-3	Wire Saddle (3 Wires)	3	F004		1/4-20 Keps Nut	6
4	7941-3	Boot, Circuit Breaker	1	F019		1/4-20 ESNA Wing Nut	2
5	7941-7	Circuit Breaker (20 Amp)	1	F026		10-24 x 1/2 PPHMS	3
6	8990-1	Hourmeter (Global)	1	F028		10-24 x 3/4 PPHMS	1
7	2703-5	Knob, 10-24 x 1/2	2	F029		1/4-20 x 1/2 Hex Bolt	3
8	4910-5	Cover Plate	1	F031		1/4-20 x 5/8 Hex Bolt	2
9	5975-1	Cable Tie (18# x 3-3/4")	2	F032		1/4-20 x 3/4 Hex Bolt	1
10	5933	Battery Terminal Insulation Red (+)	1	F050		1/4 SAE Washer	4
11	4940-6	Battery Cable (33")	1	F112		5/8 x 1-1/4 x .03 Washer	3
12	5932	Battery Terminal Insulation Black (-)	1	F349		Washer .835 ID 1.122 OD, SS	1
13	6923-4	Battery Cable, 13-1/2" (-)	1	F381		1/4-20 Hex Nut	1
14	6941-7	Relay Mount	*	F475		1/4-20 x 1 PFH Screw	1
15	6941-6	Relay Switch (20/40 Amp)	*	F505		6-32 x 7/8 Hex Trim MS, SS	4
16	7938	Lead Wire, Battery Charge (Alternator to Starter)	1	F506		6-32 Nylock Nut	4
17	5835	Cable Clamp (3/4)	1	* Service Part Only			
18	4024-13	Safety Switch Plate	1				
19	5942-8	Safety Switch (NO), Delta Side Mount	1				
20	4940-9	Wire Harness	1				
21	5942-10	Safety Switch (NC), Delta Side Mount	1				
22	NS	Battery (12V/300 CA/Wet/SP35)	1				
23	5839	Hook Bolt	2				
24	4910-1	Battery Hold Down Bracket	1				
25	8960-15	Ignition Switch W/Keys (Includes Items # 26, 27 & F349)	1				
26	7854	Plastic Tip, Red	1				
27	8960-3	Key Set W/Umbrella	1				
28	8996-9	Red Indicator Light Assembly	1				
29	8536	Warning Horn	1				

ELECTRICAL ASSEMBLY

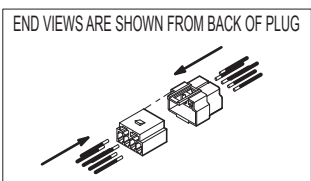
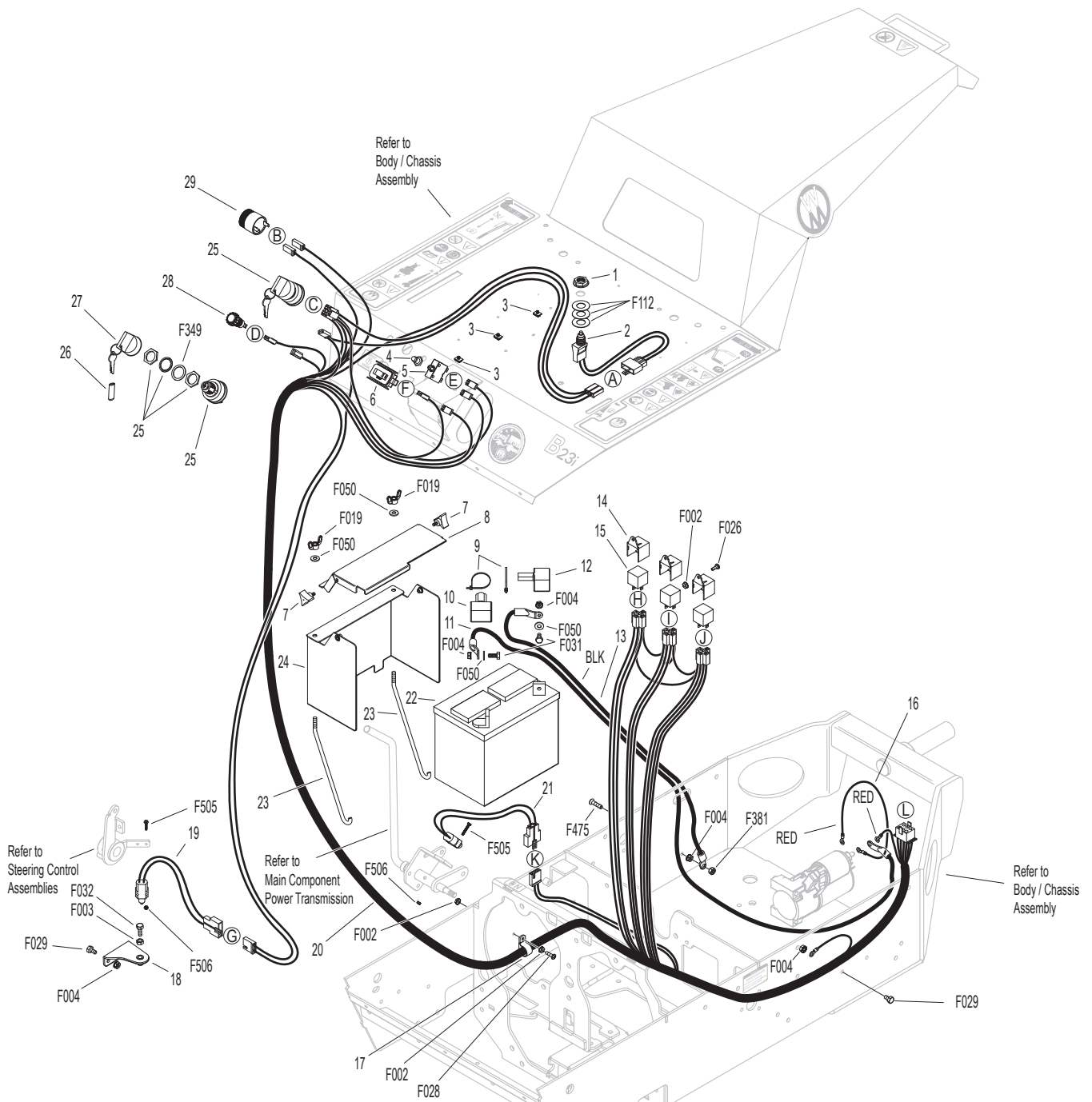

DETAIL A



DETAIL B



DETAIL C

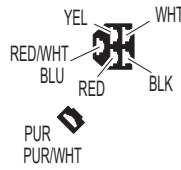

DETAIL D



DETAIL E



DETAIL F



DETAIL G



DETAIL H

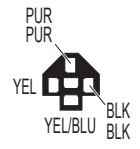

DETAIL I

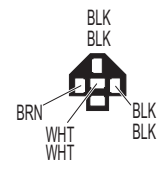

DETAIL J

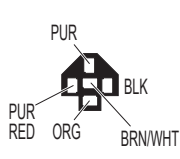

DETAIL K



DETAIL L



Beginning S/N 133534
 Effective Date 04-01-15
 Use only genuine **Walker**® replacement parts.

LUBRICATION POINTS

ITEM NO.	LOCATION	LUBRICATION TYPE	NO. PLACES	ITEM NO.	LOCATION	LUBRICATION TYPE	NO. PLACES
Lubrication Points							
1	Steering Lever Pivot	Grease	2	14	Throttle Control Cable Ends	Oil	2
2	Deck-to-PTO Coupling (Grease Spline Slide Area)	Grease	1	15	Engine Oil Filler	Oil**	1
3	Universal Joint Tube Assembly	Grease*	1	16	Brake Band Pivot Pins (Clevis)	Oil	2
4	Deck Support Arm Pivot	Grease	2	17	PTO Belt Tightener Pivot	Grease	1
5	FSC Lever Pivot	Grease	1	18	Clutch Actuator Push Rod	Grease	1
6	Body Latch Pivot	Oil	1	19	Parking Brake Clevis	Oil	2
7	Hydro Idler Arm Pivot	Grease	1	20	Parking Brake Pivot	Grease	1
8	Clutch Arm Pivot	Grease	1	21	Throttle Control Pivot	Oil	1
9	Transaxle Oil Reservoir	Oil/20W-50	1	* Grease every 25 hours.			
10	Tail Wheel Caster Fork Pivot	Grease	2	** Refer to B23i Operator's Manual for procedure for checking and changing oil in Engine Crankcase.			
11	Rear Axle Pivot	Grease	1	NOTE: See Model B23i Operator's Manual (P/N 4000-14) for proper lubrication intervals.			
12	Rear Wheel Bearing	Grease	2				
13	Engine Dipstick	Oil**	1				

LUBRICATION POINTS

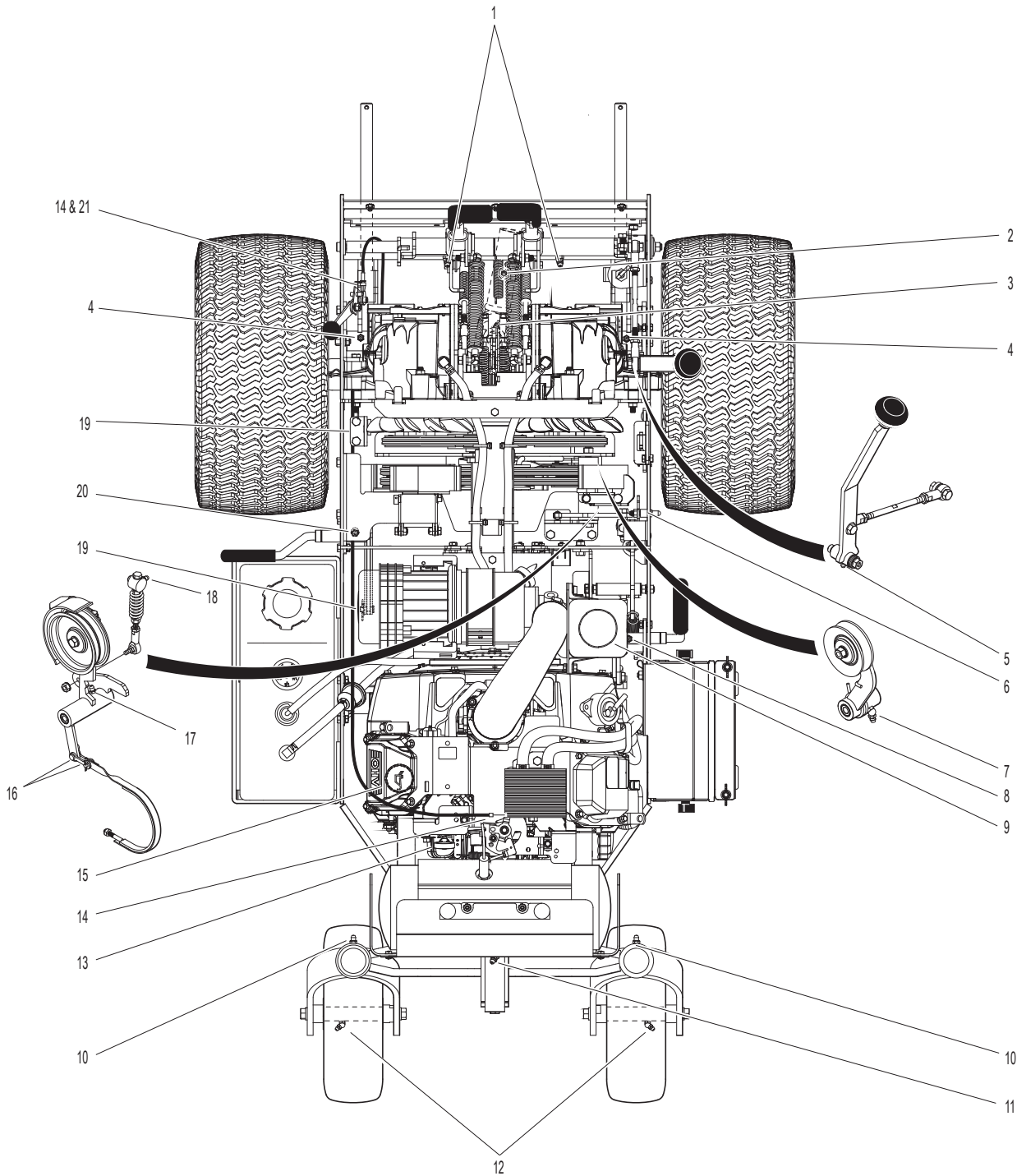

Beginning S/N 133534
Effective Date 04-01-15
Use only genuine Walker® replacement parts.

WIRING SCHEMATIC

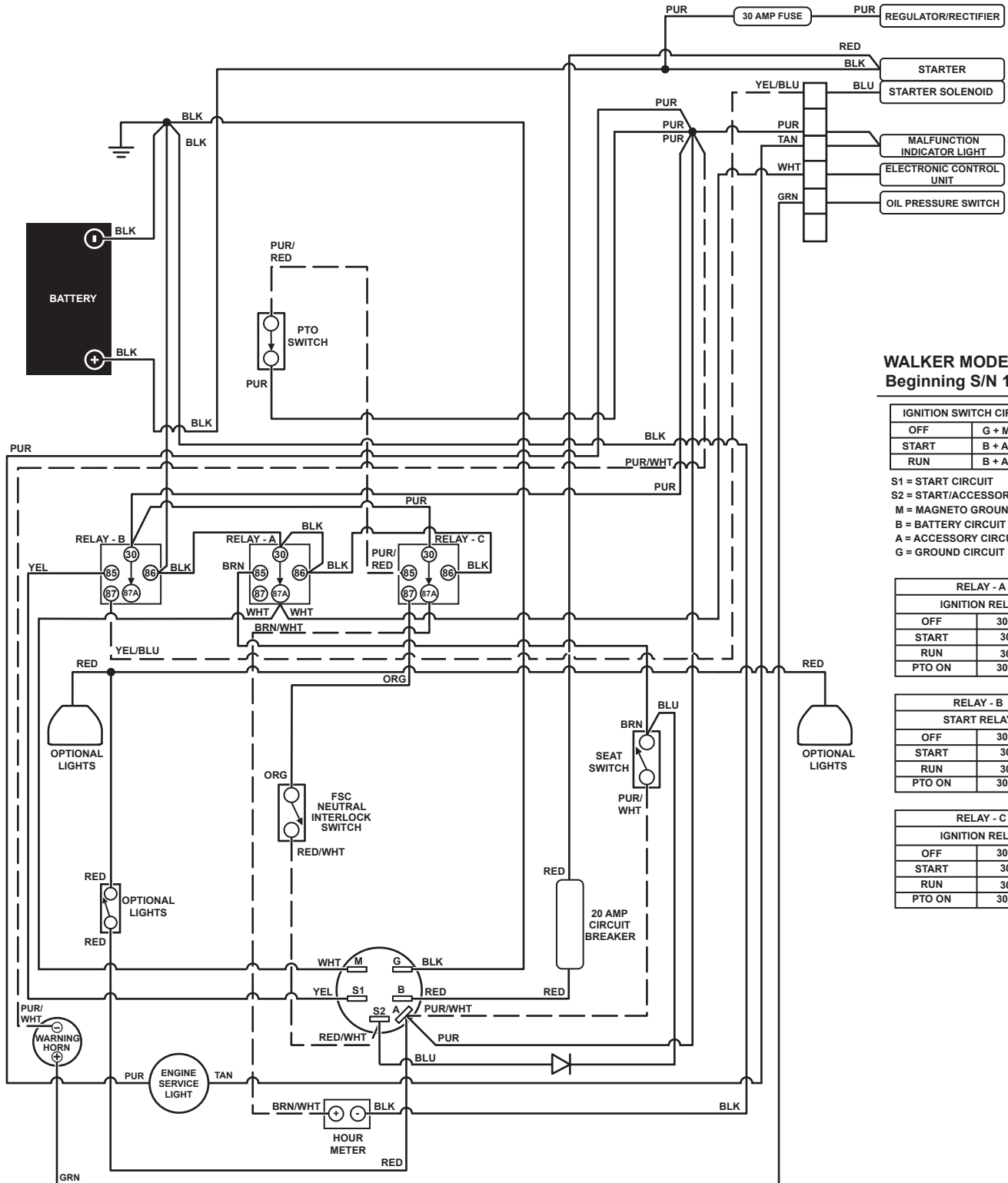

WALKER MODEL B23i Beginning S/N 133534

IGNITION SWITCH CIRCUITS	
OFF	G + M
START	B + A / S1 + S2
RUN	B + A

S1 = START CIRCUIT
 S2 = START/ACCESSORY CIRCUIT
 M = MAGNETO GROUND CIRCUIT
 B = BATTERY CIRCUIT
 A = ACCESSORY CIRCUIT
 G = GROUND CIRCUIT

RELAY - A IGNITION RELAY	
OFF	30 + 87A
START	30 + 87
RUN	30 + 87
PTO ON	30 + 87A

RELAY - B START RELAY	
OFF	30 + 87A
START	30 + 87
RUN	30 + 87
PTO ON	30 + 87A

RELAY - C IGNITION RELAY	
OFF	30 + 87A
START	30 + 87
RUN	30 + 87
PTO ON	30 + 87A

LIMITED WARRANTY FOR WALKER MODEL B23i RIDER MOWERS

1. WHAT THIS WARRANTY COVERS, AND FOR HOW LONG:

Walker Manufacturing company will, at its option, repair or replace, without charge, any part covered by this warranty which is found to be defective in material and/or workmanship within one (1) year* after date of sale to the original retail purchaser unless the product is used for rental purposes, in which case this warranty is limited to ninety (90) days. At Walker's request, customer will make the defective part available for inspection by Walker and/or return the defective part to Walker, transportation charges prepaid. All parts and components of the Walker Mower are covered by this warranty **except** the following components which are warranted separately by their respective manufacturers:

Kohler Engine
Battery

The available warranties covering these items are furnished with each mower. Walker does not assume any warranty obligation, liability or modification for these items, which are covered exclusively by the stated warranty of the respective manufacturers noted above.

* Extended warranties are offered for the following powertrain components:

- A two (2) year or 2000 hour (whichever comes first) warranty is offered for Hydro-Gear ZT3100 Hydrostatic transaxle; covers full cost of replacement up to 1000 hours of use, and after 1000 hours warranty coverage is prorated against 2000 hours..

2. WHAT THIS WARRANTY DOES NOT COVER:

- A. This warranty does not cover defects caused by depreciation or damage caused by normal wear, accidents, improper maintenance, improper use or abuse of the product, alterations, or failure to follow the instructions contained in the Operator's Manual for operation and maintenance.
- B. The customer shall pay any charges for making service calls and/or for transporting the mower to and from the place where the inspection and/or warranty work is performed.

3. HOW TO OBTAIN SERVICE UNDER THIS WARRANTY:

Warranty service can be arranged by contacting the dealer where you purchased the mower or by contacting Walker Manufacturing Company, 5925 East Harmony Road, Ft. Collins, CO 80528. Proof of the date of purchase may be required to verify warranty coverage.

4. WARRANTY LIMITATION:

- A. **THERE IS NO OTHER EXPRESS WARRANTY. ANY WARRANTY THAT MAY BE IMPLIED FROM THIS PURCHASE INCLUDING MERCHANTABILITY AND FITNESS FOR A PARTICULAR PURPOSE IS HEREBY LIMITED TO THE DURATION OF THIS WARRANTY AND TO THE EXTENT PERMITTED BY LAW ANY AND ALL IMPLIED WARRANTIES ARE EXCLUDED.** Some states do not allow limitations on how long an implied warranty lasts, so the above limitations may not apply to you.
- B. **WALKER WILL NOT BE LIABLE FOR ANY INCIDENTAL, CONSEQUENTIAL, OR SPECIAL DAMAGES AND/OR EXPENSES IN CONNECTION WITH THE PURCHASE OR USE OF THE MOWER.** Some states do not allow the exclusion or limitation of incidental or consequential damages, so the above limitation(s) or exclusion(s) may not apply to you.
- C. Only the warranty expressed in this limited warranty shall apply and no dealer, distributor, or individual is authorized to amend, modify, or extend this warranty in any way. Accordingly, additional statements such as dealer advertising or presentations, whether oral or written, do not constitute warranties by Walker, and should not be relied upon.
- D. This warranty gives you specific legal rights, and you may also have other rights which vary from state to state.

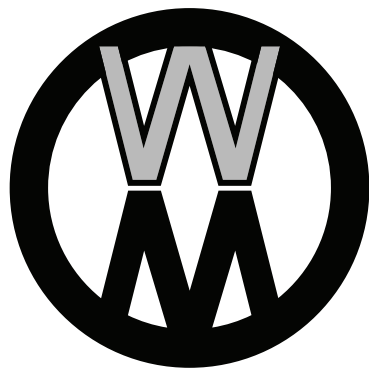

WALKER

WALKER MFG. CO. • 5925 E. HARMONY ROAD, FORT COLLINS, CO 80528 • (970) 221-5614
FORM NO. 091916 PRINTED IN USA www.walkermowers.com ©2016 WALKER MFG. CO