



WALKER

ILLUSTRATED PARTS MANUAL

Rear Discharge Deck and Carrier Frame Assemblies

DC36R
DC42
DC48
DC48R
DC52R

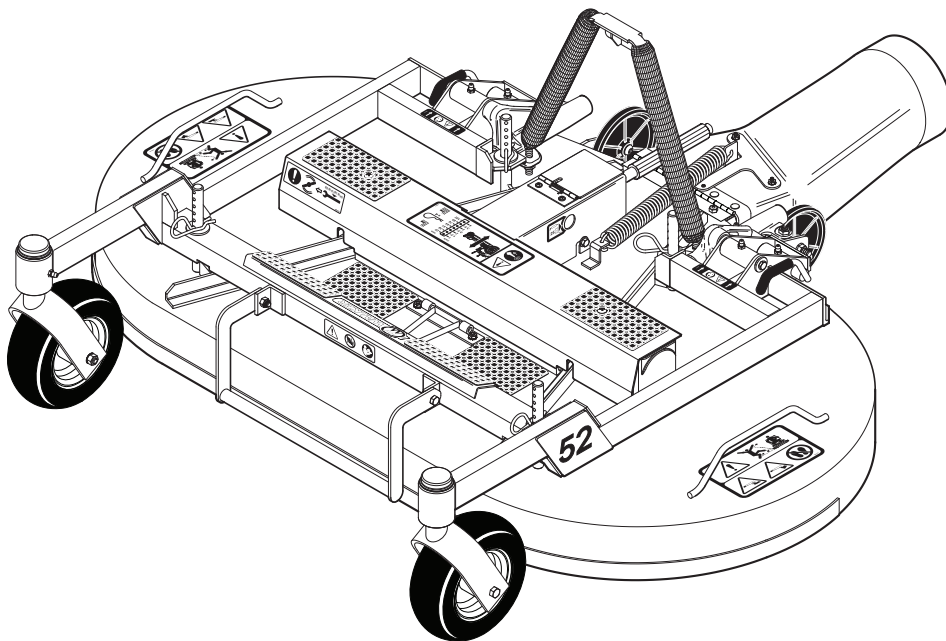

Effective Date: 04-01-13
P/N 5000-25

KEY TO ABBREVIATIONS USED IN THIS MANUAL

<i>Abbreviation</i>	<i>What it Represents</i>
° (Dimension)	Degrees (Angle)
" (Dimension)	inches
(-)	Negative (Polarity)
(+)	Positive (Polarity)
AT	All-Terrain
CCW	Counter-clockwise
Conn	Connector
CW	Clockwise
D	Diameter
DC	Deck, Collection (number refers to size in inches)
DM	Deck, Mulching (number refers to size in inches)
DR	Deck, Rear Discharge (number refers to size in inches)
DS	Deck, Side Discharge (number refers to size in inches)
DU	Garlock (Bearing)
ESNA (Fastener)	Nylon Insert Locknut
FSC	Forward Speed Control
GA	Gauge
gal	gallon
GHS	Grass Handling System
GR (Fastener)	Grade
HD	Heavy Duty
HP	Horse Power
ID	Identification or Inside Diameter
L	Length
LH	Left Hand (orientated with operator on seat)
LP	Low Profile
mm (Dimension)	millimeters
MS (Fastener)	Machine Screw
NS (as part number)	Item is not sold by Walker Manufacturing
OD	Outside Diameter
oz	ounce
PFH (Fastener)	Phillips Flat Head
P/N	Part Number
PPH (Fastener)	Phillips Pan Head
PTH (Fastener)	Phillips Truss Head
PTO	Power Take-Off
QKS	Quick Slide
qt	quart
RH	Right Hand (orientated with operator on seat)
SAE (Fastener)	Society of Automotive Engineers
SBH (Fastener)	Socket Button Head (Bolt)
SD	Side Discharge
SFH (Fastener)	Slotted Flat Head
SHC (Fastener)	Socket Head Cap
SHL (Fastener)	Shoulder (Bolt)
SM (Fastener)	Sheet Metal (Screw)
S/N	Serial Number
Spg	Spring
SQH (Fastener)	Square Head
SS (Fastener)	Stainless Steel
ST (Fastener)	Self-Tapping (Screw)
Term	Terminal
V	Volts

NOTE: In some instances, combinations of abbreviations may be used (e.g. PPHMS - Phillips Pan Head Machine Screw).

ILLUSTRATED PARTS LIST

<i>Section of Deck Covered</i>	<i>Page</i>	<i>Section of Deck Covered</i>	<i>Page</i>
<hr/>		<hr/>	
Decals & Paint		Maintenance	
36", 42", 48" & 52" Deck Decals / Touch-Up Paint2		Fastener Loctite® Application & Torque Instructions26	
Deck and Carrier Frame Assemblies		Lubrication Points28	
36R Inch Complete Carrier Frame Assembly4		Blade Usage Chart.....29	
DC36R Deck Assembly		Maintenance And Service Record Sheet.....30	
(Shear Pin Tee Gearbox and U-Joint).....6		Deck / Tractor Compatibility Chart.....30	
(Keyed Tee Gearbox and U-Joint)8		Operator's Notes31	
42 Inch Complete Carrier Frame Assembly..... 10		Warranty	
DC42 Deck Assembly 12		Limited Warranty33	
48 Inch Complete Carrier Frame Assembly..... 14			
DC48 Deck Assembly 16			
48R Inch Complete Carrier Frame Assembly 18			
DC48R Deck Assembly20			
52R Inch Complete Carrier Frame Assembly22			
DC52R Deck Assembly.....24			

36", 42", 48" & 52" DECK DECALS / TOUCH-UP PAINT

ITEM NO.	PART NO.	DESCRIPTION	LOCATION	NO. REQ'D
DC36R, DC42, DC48, DC48R & DC52R Deck Decals				
1	8600-15	Caution, Pivot Joint	Carrier Frame	2
2	6875	PTO Alignment Arrow	Universal Joint Shaft Assembly	1
3	5846-1	Grease Fitting	PTO Shaft Guard	1
4	8600-7	Cutting Height Adjustment	Gearbox Cover	1
5	8600-28	Danger, Rotating Blades	Deck Housing (one on each end)	2
6	8821-14	Decal (36")	Carrier Frame	1
	8821-15	Decal (42")	Carrier Frame	1
	8821-16	Decal (48")	Carrier Frame	1
	8821-17	Decal (52")	Carrier Frame	1
7	5809-2	Decal, Walker	Carrier Frame	1
8	8600-14	Danger, Tilt-Up	Carrier Frame, Front	1
9	8600-9	Blade Mounting Torque	Gearbox Cover	1

Touch-Up Paint

10 5866 Touch-Up Paint, Yellow (12 oz. Aerosol)

NOTE: All parts requiring decals are shipped with decals applied.

36", 42", 48" & 52" DECK DECALS / TOUCH-UP PAINT

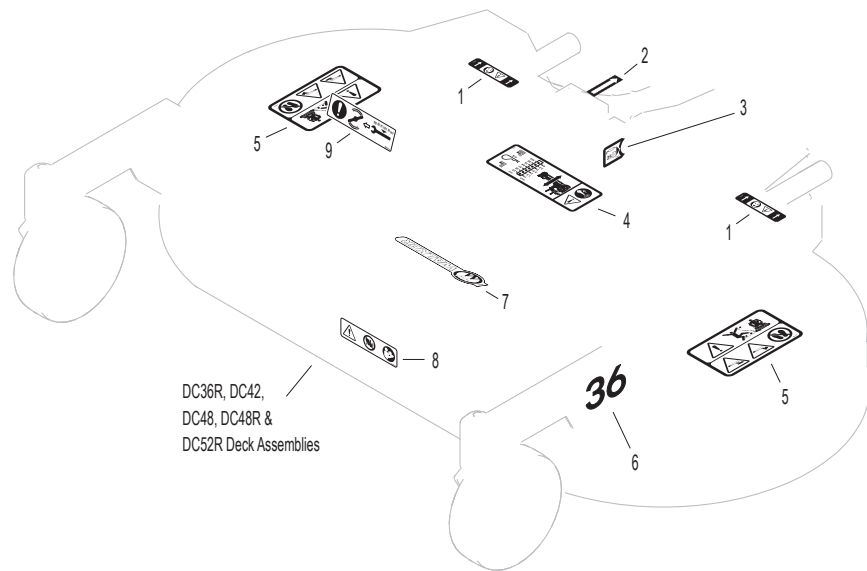

DC36R, DC42,
DC48, DC48R &
DC52R Deck Assemblies



36R INCH COMPLETE CARRIER FRAME ASSEMBLY

ITEM NO.	PART NO.	DESCRIPTION	NO. REQ'D	ITEM NO.	PART NO.	DESCRIPTION	NO. REQ'D
Spring and Pivot Mount Components				Fasteners			
1	5975-3	Cable Tie (50# x 7")	4	F012		3/8-16 Keps Nut	2
2	5744-1	Spring Clip Bracket	1	F020		5/16-18 ESNA Nut	2
3	5743-1	Spring Cover	2	F047		3/8-16 x 4-1/2 Hex Bolt	2
4	5830	Grease Fitting	8	F055		5/8 SAE Washer	2
5	8667-29	Pivot Mount Adj., LH	1	F068		1/8 x 1 Cotter Pin	2
	8667-3	Pivot Mount Assembly, LH/Adj. (Includes Items # 4, 5, F353, F489 & F520)	*	F084		5/16 Wave Spring Washer	2
6	8667-28	Pivot Mount Adj., RH	1	F098		5/8-18 Slotted Hex Nut	2
	8667-4	Pivot Mount Assembly, RH/Adj. (Includes Items # 4, 6, F353, F489 & F520)	*	F117		Retainer Ring	2
7	5743-4	Eyebolt (3/8-16 x 2-3/4)	2	F123		1" External Snap Ring	4
8	5743-8	Extension Spring (1-1/2 x 7-3/4) (Includes Items # 1, F117 & F166)	2	F166		Retainer Ring	2
Carrier Frame Components				F226		5/16-18 x 7/8 Hex Bolt	2
9	8674-11	Lever, Deck Lock, LH	1	F317		3/16 x 1 Split Spring Pin	2
10	7406-1	Handle Grip (Red)	2	F335		3/8-16 x 7/8 Set Screw, SS	2
11	8669	Lift Handle	1	F336		3/8-16 Jam Nut	2
12	5748-10	Rubber Mat (1-1/2 x 6)	2	F353		3/8-16 ESNA LP Nut	2
13	5740-2	Deck Pin Bushing (5/8)	4	F489		Washer 1/4 x 7/8 x .090	2
14	5708-6	36" Carrier Frame (Less Pivots) (Includes Item # 12)	1	F520		1/4-28 x 3/8 Hex Bolt	2
	5708-1	36" Carrier Frame w/Forks (Less Pivots) (Includes Items # 12, 21-23, 25, F055, F068 & F098)	*	* Service Part Only			
15	8674-10	Lever, Deck Lock, RH	1	** May be ordered as a kit for dealer installation. Contact your Walker dealer.			
Caster Wheel Components							
16	5714-7	Bearing Cap	4				
17	5714-5	Bearing, Caster Wheel	2				
18	5830-3	Grease Fitting (45 Degree)	2				
19	5715-4	Caster Wheel, Pneumatic (8 x 3.00-4) (Includes Items # 16-18)	2				
	5715-10	Tire, Pneumatic (8 x 3.00-4)	*				
	5715-9	Tire Tube, Pneumatic (2.80/2.50-4)	*				
	5715-3	Caster Wheel & Tire/No-Flat (8 x 3.00-4)	**				
	5715-11	Tire, Caster Wheel/No-Flat (8 x 3.00-4)	**				
20	5714-3	Axle Spacer Tube	2				
21	5770-1	Caster Wheel Fork	2				
22	8768-1	Seal (1-3/4 x 1-1/8)	2				
23	8037	Bearing Cone (3/4 ID)	4				
24	8769-1	Bearing Cup (1-3/4 x 1-7/16)	4				
25	8769-9	Dust Cap, Deck Caster	2				

DC36R DECK ASSEMBLY (SHEAR PIN TEE GEARBOX AND U-JOINT)

INCL. OPTIONAL HD GEARBOXES

ITEM NO.	PART NO.	DESCRIPTION	NO. REQ'D	ITEM NO.	PART NO.	DESCRIPTION	NO. REQ'D
Gearbox and Drive Components				33	NS	Deck Serial Number Plate	1
1	8618-1	Cover, PTO Shaft Guard	1	34	5705-36	Blade, 19" (RH Rotation)	1
2	8619	PTO Shaft Guard	1	35	5705-35	Blade, 19" (LH Rotation)	1
	8618	PTO Shaft Guard Assembly (Includes Items # 1, 2, F002 & F025)	*	36	5706	Blade Hub & Trash Guard	2
3	5285-15	U-Joint Shaft Assembly, 90 Degree, Spline (Includes Items # 27, F069 & F295)	1	37	7775-1	Hitch Pin, LH (Silver) #6	2
4	7275-16	U-Joint Tube Assembly, Spline	1	38	8735-10	Rubber Mat (5 x 6)	2
5	5275-15	U-Joint Tube Assembly (9.5" OAL), Spline (Includes Item # F076)	1	39	8788-1	Rubber Mat (1 x 2)	1
6	5704-94	Gearbox and Tube Assembly (Includes Items # 15-23, F124, F136, F179 & F211)	*	40	7775-2	Hitch Pin, RH (Gold) #6	2
	5704-93	HD Gearbox and Tube Assembly (Includes Items # 15-19, 21-23, F136, F179 & F211)	**	41	5727-1	Washer Shim (5/8 ID)	4
7	5794	Discharge Chute W/O Spring Mount (Includes Items # 7, 10-12 & F462)	1	Fasteners			
	5794-1	Discharge Chute with Spring Mount (Includes Items # 7, 8, 10-12 & F462)	*	F002	10-24 Keps Nut		9
8	8678	Spring Mount, Chute	1	F004	1/4-20 Keps Nut		2
9	8677	Extension Spring (1 x 6-1/16)	1	F005	1/4-20 ESNA Nut		2
10	5726	Chute Hinge (2 x 8)	1	F013	3/8-16 Whiz Locknut		6
11	5755-2	Chute Lip, Top	1	F018	5/8-18 Hex Nut		2
12	5755-3	Chute Lip, Bottom	1	F025	10-24 x 3/8 PPHMS		2
13	8678-4	Spring Mount, Chute	1 ^Δ	F029	1/4-20 x 1/2 Hex Bolt		2
14	5794-3	Discharge Chute with Spring Mount (Includes Items # 10-13 & F462)	1 ^Δ	F036	1/4-20 x 1/2 SBH Screw		2
15	6054	Spline Coupling	3	F038	3/8-16 x 1 Hex Bolt		4***
16	P007	Gasket, Cap (Peerless #788030)	4	F039	3/8-16 x 1-1/4 Hex Bolt		4
17	5065	Gearbox Connector Tube (7-11/16)	1	F050	1/4 SAE Washer		4
18	6733-4	Connecting Shaft (5-5/16)	1	F055	5/8 SAE Washer		2
19	5052-11	Gearbox, LH (1:1.2)	2	F056	5/8 Split Lock Washer		2
	5052-6	HD Gearbox, LH (1:1.2)	**	F059	3/8 Wave Spring Washer		2
20	5706-4	Seal Protector Plate	2	F069	3/32 x 1/2 Cotter Pin		1
21	5704-1	Gearbox Cover Support	2	F076	3/8-16 x 5/8 SQH Set Screw		*
22	5051-16	Tee Gearbox, Shear	*	F087	#10 x 7/8 Fender Washer		2
	5051-9	HD Tee Gearbox Reverse, Shear	**	F124	10-32 x 3/8 Tapitite Machine Screw		6
23	5060	Gearbox Connector Tube (2-5/16)	1	F129	10-24 x 1/2 PTHMS		3
24	5052-3	1.375 x .750 x .187 Washer	4	F136	AN960C416L Washer		16
25	5747-11	Rubber Mat (3 x 6)	2	F179	1/4-20 x 1 Hex Bolt		4
26	5746-6	DML36 Gearbox Cover (Includes Item # 25)	1	F202	10-24 x 5/8 SHC Screw, GR5 SS		4
27	8067-13	Shear Pin w/Cotter (Set of 5) (Includes Item # F069)	*	F206	#2 x 3/16 Drive Pin		2
28	5830	Grease Fitting	1	F211	1/4-20 x 7/8 Hex Bolt		12
Deck Housing Components				F246	1/4-20 x 1/2 PTHMS		2
29	8670	Tilt-Up Hook	1	F278	3/8 Split Lock Washer		4***
30	5162-11	Roller Wheel (5" Poly) (Includes Item # F059)	2	F295	3/16 x 1-1/2 Split Spring Pin		1
31	8490	Roller Wheel Axle Bolt	2	F403	1/4-20 x 1/2 PTHMS, SS		2
32	5710-6	DC36R Deck Housing (Includes Items # 38 & 39)	1	F462	3/16 x .468 (+/- .010) Semi-Tube Rivet		9
				F517	Washer 3/8 x 1-1/8 x 1/8		4***
				* Service Part Only			
				** Item(s) used on the HD version of standard gearboxes. The HD cast iron gearboxes are interchangeable with Standard aluminum gearboxes.			
				*** Used on HD gearbox configuration.			
				^Δ Item used on Model S14 only			
				NOTE: Order Item # 4 to use the splined deck PTO shaft with Model T23, T25i, T30i, D21d and C19.			
				NOTE: Order Item # 5 to use the splined deck PTO shaft with Model S14.			

DC36R DECK ASSEMBLY (SHEAR PIN TEE GEARBOX AND U-JOINT) INCL. OPTIONAL HD GEARBOXES

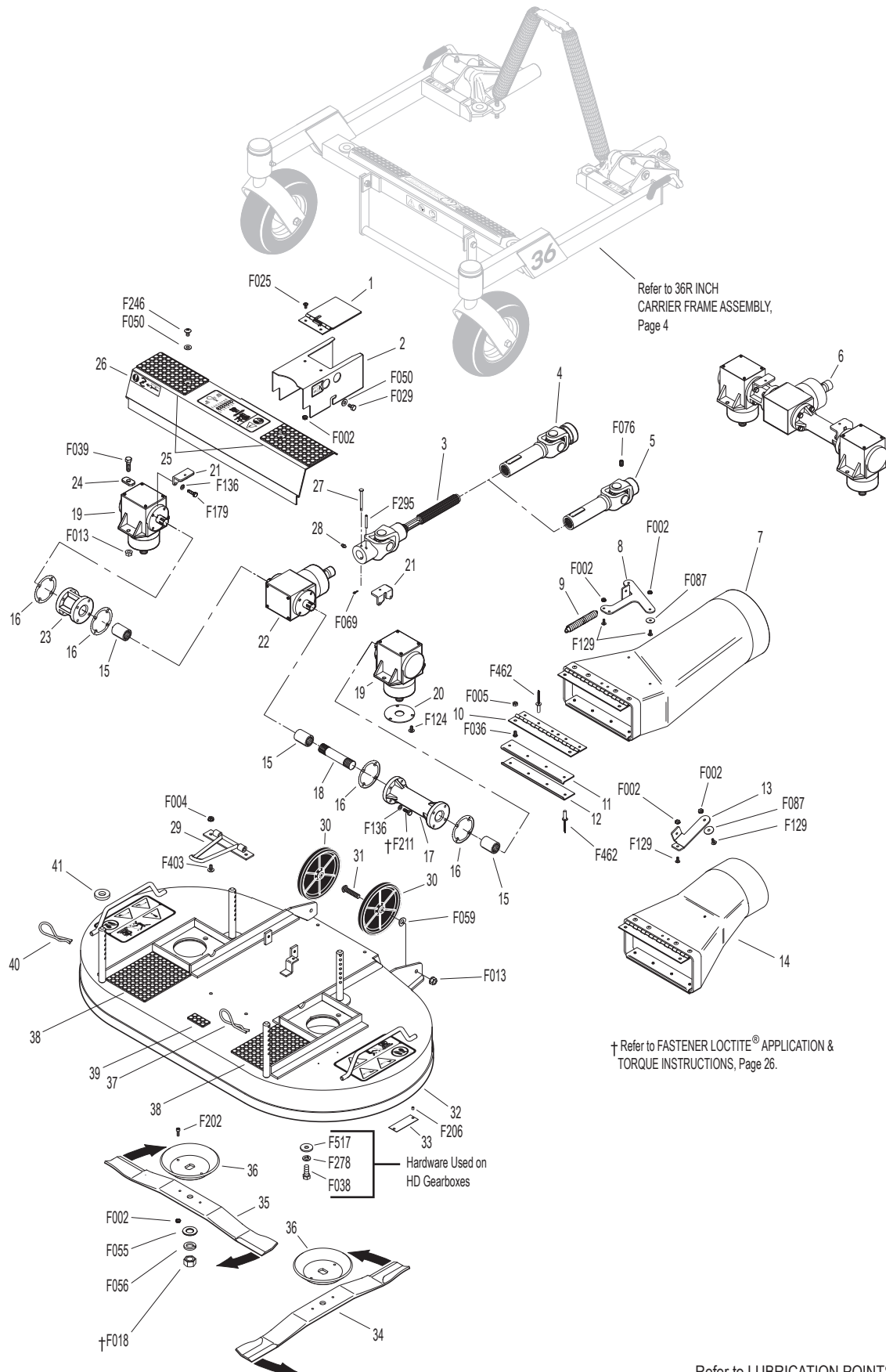

DC36R DECK ASSEMBLY (KEYED TEE GEARBOX AND U-JOINT)

ITEM NO.	PART NO.	DESCRIPTION	NO. REQ'D	ITEM NO.	PART NO.	DESCRIPTION	NO. REQ'D
Gearbox and Drive Components				33	5705-35	Blade, 19" (LH Rotation)	1
1	8618-1	Cover, PTO Shaft Guard	1	34	5706	Blade Hub & Trash Guard	2
2	8619	PTO Shaft Guard	1	35	7775-1	Hitch Pin, LH (Silver) #6	2
	8618	PTO Shaft Guard Assembly (Includes Items # 1, 2, F002 & F025)	*	36	8735-10	Rubber Mat (5 x 6)	2
3	5285-5	U-Joint Shaft Assembly, 90 Degree, Spline, Keyed (Includes Items # F065 & F318)	1	37	8788-1	Rubber Mat (1 x 2)	1
4	7275-16	U-Joint Tube Assembly, Spline	1	38	7775-2	Hitch Pin, RH (Gold) #6	2
5	5275-15	U-Joint Tube Assembly (9.5" OAL), Spline (Includes Item # F076)	1	39	5727-1	Washer Shim (5/8 ID)	4
6	6704-33	Gearbox and Tube Assembly (Includes Items # 15-23, F124, F136, F179 & F211)	*	Fasteners			
7	5794	Discharge Chute W/O Spring Mount (Includes Items # 7, 10-12 & F462)	1	F002	10-24 Keps Nut		9
	5794-1	Discharge Chute with Spring Mount (Includes Items # 7, 8, 10-12 & F462)	*	F004	1/4-20 Keps Nut		2
8	8678	Spring Mount, Chute	1	F005	1/4-20 ESNA Nut		2
9	8677	Extension Spring (1 x 6-1/16)	1	F013	3/8-16 Whiz Locknut		6
10	5726	Chute Hinge (2 x 8)	1	F018	5/8-18 Hex Nut		2
11	5755-2	Chute Lip, Top	1	F025	10-24 x 3/8 PPHMS		2
12	5755-3	Chute Lip, Bottom	1	F029	1/4-20 x 1/2 Hex Bolt		2
13	8678-4	Spring Mount, Chute	1 ^Δ	F036	1/4-20 x 1/2 SBH Screw		2
14	5794-3	Discharge Chute with Spring Mount (Includes Items # 10-13 & F462)	1 ^Δ	F039	3/8-16 x 1-1/4 Hex Bolt		4
15	6054	Spline Coupling	3	F050	1/4 SAE Washer		4
16	P007	Gasket, Cap (Peerless #788030)	4	F055	5/8 SAE Washer		2
17	5065	Gearbox Connector Tube (7-11/16)	1	F056	5/8 Split Lock Washer		2
18	6733-4	Connecting Shaft (5-5/16)	1	F059	3/8 Wave Spring Washer		2
19	5052-11	Gearbox, LH (1:1.2)	2	F065	3/16 x 3/4 Woodruff Key (#606)		1
20	5706-4	Seal Protector Plate	2	F076	3/8-16 x 5/8 SQH Set Screw		*
21	5704-1	Gearbox Cover Support	2	F087	#10 x 7/8 Fender Washer		2
22	5051-2	Tee Gearbox (7/8" Dia. Shaft)	1	F124	10-32 x 3/8 Tapitite Machine Screw		6
23	5060	Gearbox Connector Tube (2-5/16)	1	F129	10-24 x 1/2 PTHMS		3
24	5052-3	1.375 x .750 x .187 Washer	4	F136	AN960C416L Washer		16
25	5747-11	Rubber Mat (3 x 6)	2	F179	1/4-20 x 1 Hex Bolt		4
26	5746-6	DML36 Gearbox Cover (Includes Item # 25)	1	F202	10-24 x 5/8 SHC Screw, GR5 SS		4
Deck Housing Components				F206	#2 x 3/16 Drive Pin		2
27	8670	Tilt-Up Hook	1	F211	1/4-20 x 7/8 Hex Bolt		12
28	5162-11	Roller Wheel (5" Poly) (Includes Item # F059)	2	F246	1/4-20 x 1/2 PTHMS		2
29	8490	Roller Wheel Axle Bolt	2	F318	3/8-16 x 3/4 SQH Set Screw		2
30	5710-6	DC36R Deck Housing (Includes Items # 36 & 37)	1	F403	1/4-20 x 1/2 PTHMS, SS		2
31	NS	Deck Serial Number Plate	1	F462	3/16 x .468 (+/- .010) Semi-Tube Rivet		9
32	5705-36	Blade, 19" (RH Rotation)	1	* Service Part Only			
				Δ Item used on Model S14 only			
				NOTE: Order Item # 4 to use the splined deck PTO shaft with Model T23, T25i, T30i, D21d and C19.			
				NOTE: Order Item # 5 to use the splined deck PTO shaft with Model S14.			

DC36R DECK ASSEMBLY (KEYED TEE GEARBOX AND U-JOINT)

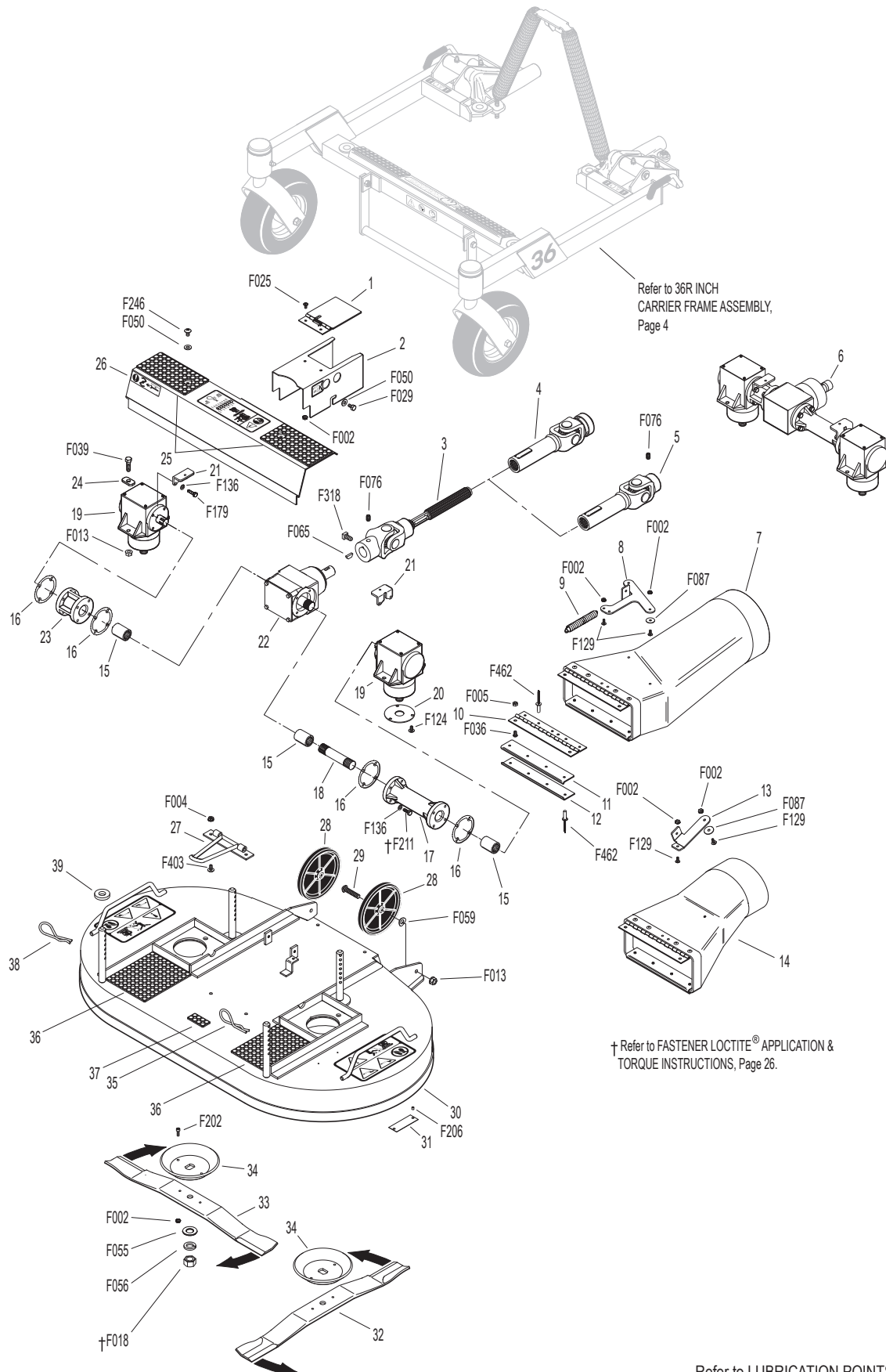

Refer to LUBRICATION POINTS, Page 28.

42 INCH COMPLETE CARRIER FRAME ASSEMBLY

ITEM NO.	PART NO.	DESCRIPTION	NO. REQ'D	ITEM NO.	PART NO.	DESCRIPTION	NO. REQ'D
Spring and Pivot Mount Components				Fasteners			
1	5975-3	Cable Tie (50# x 7")	4	F012		3/8-16 Keps Nut	2
2	5744-1	Spring Clip Bracket	1	F020		5/16-18 ESNA Nut	2
3	5743-1	Spring Cover	2	F047		3/8-16 x 4-1/2 Hex Bolt	2
4	5743-4	Eyebolt (3/8-16 x 2-3/4)	2	F055		5/8 SAE Washer	2
5	5830	Grease Fitting	8	F068		1/8 x 1 Cotter Pin	2
6	8667-29	Pivot Mount Adj., LH	1	F084		5/16 Wave Spring Washer	2
	8667-3	Pivot Mount Assembly, LH/Adj. (Includes Items # 5, 6, F353, F489 & F520)	*	F098		5/8-18 Slotted Hex Nut	2
7	8667-28	Pivot Mount Adj., RH	1	F117		Retainer Ring	2
	8667-4	Pivot Mount Assembly, RH/Adj. (Includes Items # 5, 7, F353, F489 & F520)	*	F123		1" External Snap Ring	4
8	5743-8	Extension Spring (1-1/2 x 7-3/4) (Includes Items # 1, F117 & F166)	2	F166		Retainer Ring	2
				F226		5/16-18 x 7/8 Hex Bolt	2
				F317		3/16 x 1 Split Spring Pin	2
				F335		3/8-16 x 7/8 Set Screw, SS	2
				F336		3/8-16 Jam Nut	2
				F353		3/8-16 ESNA LP Nut	2
				F489		Washer 1/4 x 7/8 x .090	2
				F520		1/4-28 x 3/8 Hex Bolt	2
Carrier Frame Components				* Service Part Only			
9	8674-11	Lever, Deck Lock, LH	1	** May be ordered as a kit for dealer installation. Contact your Walker dealer.			
10	7406-1	Handle Grip (Red)	2				
11	8669	Lift Handle	1				
12	5748-10	Rubber Mat (1-1/2 x 6)	2				
13	5740-2	Deck Pin Bushing (5/8)	4				
14	8660-13	42" Carrier Frame (Less Pivots) (Includes Item # 12)	1				
	8660-12	42" Carrier Frame w/Forks (Less Pivots) (Includes Items # 12, 21-23, 25, F055, F068 & F098)	*				
15	8674-10	Lever, Deck Lock, RH	1				
Caster Wheel Components							
16	5714-7	Bearing Cap	4				
17	5714-5	Bearing, Caster Wheel	2				
18	5830-3	Grease Fitting (45 Degree)	2				
19	5715-4	Caster Wheel, Pneumatic (8 x 3.00-4) (Includes Items # 16-18)	2				
	5715-10	Tire, Pneumatic (8 x 3.00-4)	*				
	5715-9	Tire Tube, Pneumatic (2.80/2.50-4)	*				
	5715-3	Caster Wheel & Tire/No-Flat (8 x 3.00-4)	**				
	5715-11	Tire, Caster Wheel/No-Flat (8 x 3.00-4)	**				
20	5714-3	Axle Spacer Tube	2				
21	5770-1	Caster Wheel Fork	2				
22	8768-1	Seal (1-3/4 x 1-1/8)	2				
23	8037	Bearing Cone (3/4 ID)	4				
24	8769-1	Bearing Cup (1-3/4 x 1-7/16)	4				
25	8769-9	Dust Cap, Deck Caster	2				

42 INCH COMPLETE CARRIER FRAME ASSEMBLY

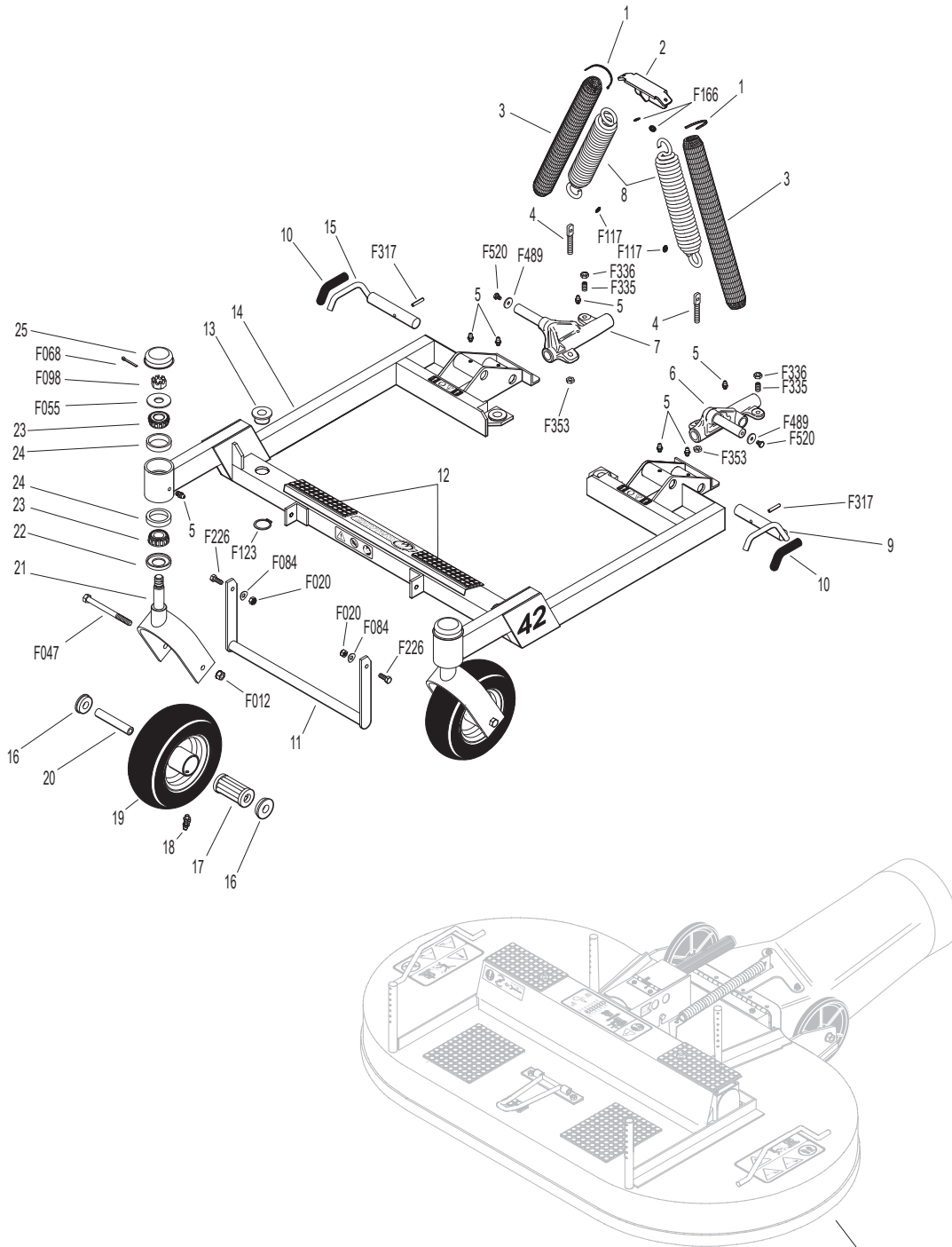

Refer to DC42
DECK ASSEMBLY, Page 12

Refer to LUBRICATION POINTS, Page 28.

DC42 DECK ASSEMBLY

INCL. OPTIONAL HD GEARBOXES

ITEM NO.	PART NO.	DESCRIPTION	NO. REQ'D	ITEM NO.	PART NO.	DESCRIPTION	NO. REQ'D
Gearbox and Drive Components				36	5705-4	Blade, 22" (LH Rotation)	1
1	8618-1	Cover, PTO Shaft Guard	1		5705-8	42 GHS Blade Set with Hubs (Includes Items # 34-36, F002 & F202)	*
2	8619	PTO Shaft Guard	1				
	8618	PTO Shaft Guard Assembly (Includes Items # 1, 2, F002 & F025)	*	37	8735-10	Rubber Mat (5 x 6)	2
3	5285-15	U-Joint Shaft Assembly, 90 Degree, Spline (Includes Items # 29, F069 & F295)	1	38	7775-1	Hitch Pin, LH (Silver) #6	2
4	7275-16	U-Joint Tube Assembly, Spline	1	39	8788-1	Rubber Mat (1 x 2)	1
5	5275-15	U-Joint Tube Assembly (9.5" OAL), Spline (Includes Item # F076)	1	40	5704-4	42 GHS Deck Housing (Includes Items # 37 & 39)	1
6	5704-50	Gearbox and Tube Assembly (Includes Items # 15-24, F124, F136, F179 & F211)	1	41	7775-2	Hitch Pin, RH (Gold) #6	2
	5704-8	HD Gearbox and Tube Assembly (Includes Items # 15-19, 21-24, F136, F179 & F211)	**	42	5727-1	Washer Shim (5/8 ID)	4
7	5794	Discharge Chute W/O Spring Mount (Includes Items # 7, 10-12 & F462)	1	Fasteners			
	5794-1	Discharge Chute with Spring Mount (Includes Items # 7, 8, 10-12 & F462)	*	F002	10-24 Keps Nut		9
8	8678	Spring Mount, Chute	1	F004	1/4-20 Keps Nut		2
9	8677	Extension Spring (1 x 6-1/16)	1	F005	1/4-20 ESNA Nut		2
10	5726	Chute Hinge (2 x 8)	1	F013	3/8-16 Whiz Locknut		6
11	5755-2	Chute Lip, Top	1	F018	5/8-18 Hex Nut		2
12	5755-3	Chute Lip, Bottom	1	F025	10-24 x 3/8 PPHMS		2
13	8678-4	Spring Mount, Chute	1 ^Δ	F029	1/4-20 x 1/2 Hex Bolt		2
14	5794-20	Discharge Chute with Spring Mount (Includes Items # 10-13 & F462)	1 ^Δ	F036	1/4-20 x 1/2 SBH Screw		2
15	6054	Spline Coupling	4	F038	3/8-16 x 1 Hex Bolt		4***
16	P007	Gasket, Cap (Peerless #788030)	4	F039	3/8-16 x 1-1/4 Hex Bolt		4
17	5063	Gearbox Connector Tube (8-5/8)	1	F050	1/4 SAE Washer		4
18	6733-3	Connecting Shaft (6-1/4)	1	F055	5/8 SAE Washer		2
19	5052-1	Gearbox (LH Rotation)	2	F056	5/8 Split Lock Washer		2
	5052-5	HD Gearbox (LH Rotation)	**	F059	3/8 Wave Spring Washer		2
20	5706-4	Seal Protector Plate	2	F069	3/32 x 1/2 Cotter Pin		1
21	5704-1	Gearbox Cover Support	2	F076	3/8-16 x 5/8 SQH Set Screw		*
22	5051-16	Tee Gearbox, Shear	1	F087	#10 x 7/8 Fender Washer		2
	5051-6	HD Tee Gearbox, Shear	**	F124	10-32 x 3/8 Tapitite Machine Screw		6
23	6733-1	Connecting Shaft (2")	1	F129	10-24 x 1/2 PTHMS		3
24	5062	Gearbox Connector Tube (4-3/8)	1	F136	AN960C416L Washer		16
25	5052-3	1.375 x .750 x .187 Washer	4	F179	1/4-20 x 1 Hex Bolt		4
26	5747-11	Rubber Mat (3 x 6)	2	F202	10-24 x 5/8 SHC Screw, GR5 SS		4
27	5785-5	42" Gearbox Cover (Includes Item # 26)	1	F206	#2 x 3/16 Drive Pin		2
28	5830	Grease Fitting	1	F211	1/4-20 x 7/8 Hex Bolt		12
29	8067-13	Shear Pin w/Cotter (Set of 5) (Includes Item # F069)	*	F246	1/4-20 x 1/2 PTHMS		2
Deck Housing Components				F278	3/8 Split Lock Washer		4***
30	8670	Tilt-Up Hook	1	F295	3/16 x 1-1/2 Split Spring Pin		1
31	5162-11	Roller Wheel (5" Poly) (Includes Item # F059)	2	F403	1/4-20 x 1/2 PTHMS, SS		2
32	8490	Roller Wheel Axle Bolt	2	F462	3/16 x .468 (+/- .010) Semi-Tube Rivet		9
33	NS	Deck Serial Number Plate	1	F517	Washer 3/8 x 1-1/8 x 1/8		4***
34	5705-3	Blade, 22" (RH Rotation)	1	* Service Part Only			
35	5706	Blade Hub & Trash Guard	2	** Item(s) used on the HD version of standard gearboxes. The HD cast iron gearboxes are interchangeable with Standard aluminum gearboxes.			
				*** Used on HD gearbox configuration.			
				^Δ Item used on Model S14 only			
				NOTE: Order Item # 4 to use the splined deck PTO shaft with Model T23, T25i, T30i, D21d and C19.			
				NOTE: Order Item # 5 to use the splined deck PTO shaft with Model S14.			

DC42 DECK ASSEMBLY

INCL. OPTIONAL HD GEARBOXES

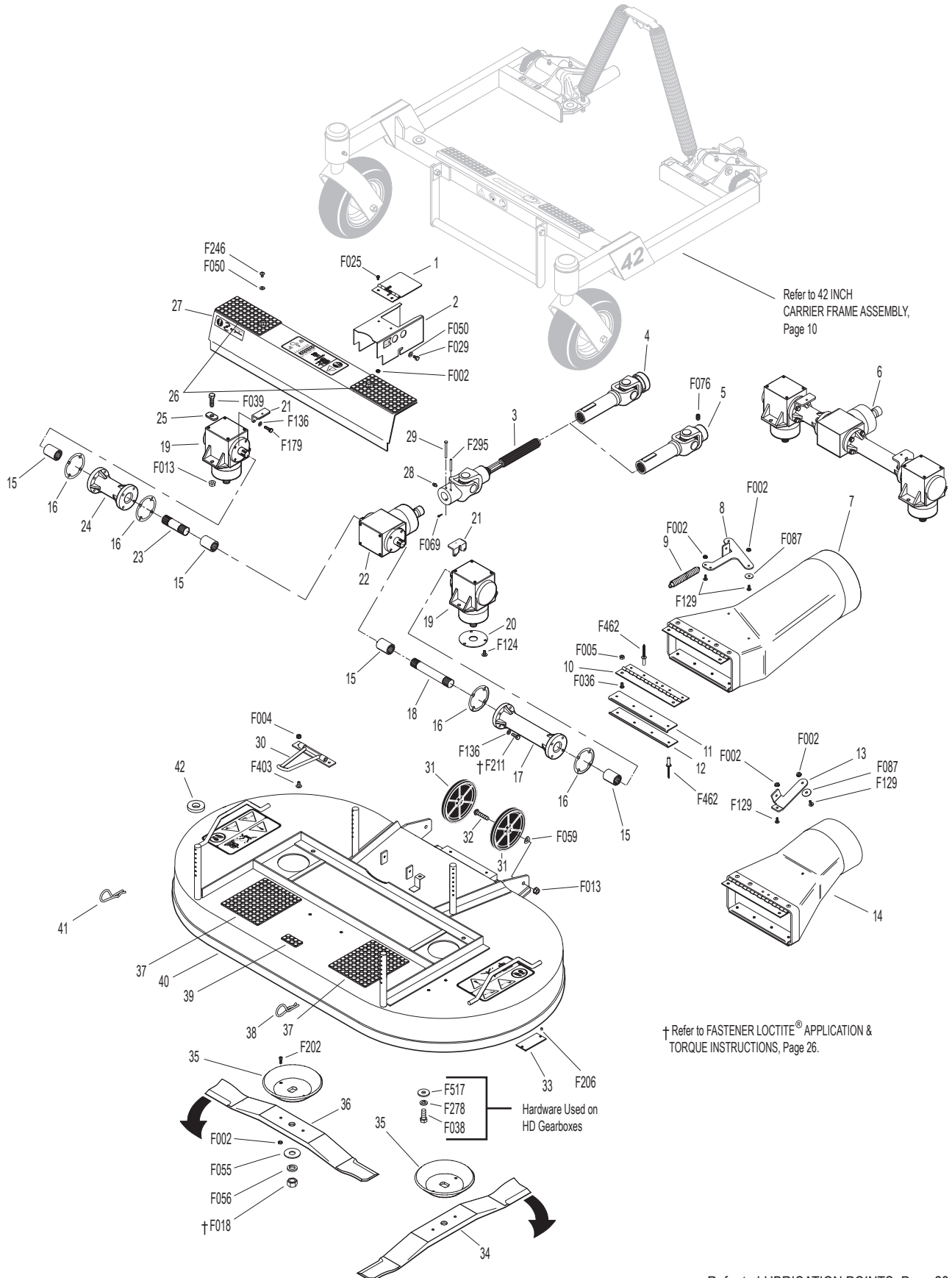

48 INCH COMPLETE CARRIER FRAME ASSEMBLY

ITEM NO.	PART NO.	DESCRIPTION	NO. REQ'D	ITEM NO.	PART NO.	DESCRIPTION	NO. REQ'D
Spring and Pivot Mount Components				Fasteners			
1	5975-3	Cable Tie (50# x 7")	4	F012		3/8-16 Keps Nut	2
2	5744-1	Spring Clip Bracket	1	F014		3/8-16 ESNA Nut	2
3	5743-1	Spring Cover	2	F020		5/16-18 ESNA Nut	2
4	5743-3	Eyebolt (3/8-16 x 2)	2	F047		3/8-16 x 4-1/2 Hex Bolt	2
5	5830	Grease Fitting	8	F055		5/8 SAE Washer	2
6	8667-29	Pivot Mount Adj., LH	1	F068		1/8 x 1 Cotter Pin	2
	8667-3	Pivot Mount Assembly, LH/Adj. (Includes Items # 5, 6, F014, F489 & F520)	*	F084		5/16 Wave Spring Washer	2
7	8667-28	Pivot Mount Adj., RH	1	F098		5/8-18 Slotted Hex Nut	2
	8667-4	Pivot Mount Assembly, RH/Adj. (Includes Items # 5, 7, F014, F489 & F520)	*	F117		Retainer Ring	2
8	5743-8	Extension Spring (1-1/2 x 7-3/4) (Includes Items # 1, F117 & F166)	2	F123		1" External Snap Ring	4
				F166		Retainer Ring	2
				F226		5/16-18 x 7/8 Hex Bolt	2
				F317		3/16 x 1 Split Spring Pin	2
				F335		3/8-16 x 7/8 Set Screw, SS	2
				F336		3/8-16 Jam Nut	2
				F489		Washer 1/4 x 7/8 x .090	2
				F520		1/4-28 x 3/8 Hex Bolt	2
Carrier Frame Components				* Service Part Only			
9	8674-11	Lever, Deck Lock, LH	1	** May be ordered as a kit for dealer installation. Contact your Walker dealer.			
10	7406-1	Handle Grip (Red)	2				
11	8669	Lift Handle	1				
12	5748-10	Rubber Mat (1-1/2 x 6)	2				
13	5740-2	Deck Pin Bushing (5/8)	4				
14	8661-2	48" Carrier Frame (Less Pivots) (Includes Item # 12)	1				
	8661-1	48" Carrier Frame w/Forks (Less Pivots) (Includes Items # 12, 21-23, 25, F055, F068 & F098)	*				
15	8674-10	Lever, Deck Lock, RH	1				
Caster Wheel Components							
16	5714-7	Bearing Cap	4				
17	5714-5	Bearing, Caster Wheel	2				
18	5830-3	Grease Fitting (45 Degree)	2				
19	5715-4	Caster Wheel, Pneumatic (8 x 3.00-4) (Includes Items # 16-18)	2				
	5715-10	Tire, Pneumatic (8 x 3.00-4)	*				
	5715-9	Tire Tube, Pneumatic (2.80/2.50-4)	*				
	5715-3	Caster Wheel & Tire/No-Flat (8 x 3.00-4)	**				
	5715-11	Tire, Caster Wheel/No-Flat (8 x 3.00-4)	**				
20	5714-3	Axle Spacer Tube	2				
21	5770-1	Caster Wheel Fork	2				
22	8768-1	Seal (1-3/4 x 1-1/8)	2				
23	8037	Bearing Cone (3/4 ID)	4				
24	8769-1	Bearing Cup (1-3/4 x 1-7/16)	4				
25	8769-9	Dust Cap, Deck Caster	2				

DC48 DECK ASSEMBLY

INCL. OPTIONAL HD GEARBOXES

ITEM NO.	PART NO.	DESCRIPTION	NO. REQ'D	ITEM NO.	PART NO.	DESCRIPTION	NO. REQ'D
Gearbox and Drive Components				31	7705-1	Blade, 25" (RH Rotation)	1
1	8618-1	Cover, PTO Shaft Guard	1	32	5706	Blade Hub & Trash Guard	2
2	8619	PTO Shaft Guard	1	33	7705-2	Blade, 25" (LH Rotation)	1
	8618	PTO Shaft Guard Assembly (Includes Items # 1, 2, F002 & F025)	*		7705-3	48 GHS Blade Set with Hubs (Includes Items # 31-33, F002 & F202)	*
3	7285-15	U-Joint Shaft Assembly, 90 Degree, Spline (Includes Items # 26, F069 & F295)	1	34	7775-1	Hitch Pin, LH (Silver) #6	2
4	7275-16	U-Joint Tube Assembly, Spline	1	35	8735-10	Rubber Mat (5 x 6)	2
5	7794	48 GHS Discharge Chute W/O Spring (Includes Items # 5, 9-11 & F462)	1	36	8788-1	Rubber Mat (1 x 2)	1
	7794-1	Discharge Chute Assembly with Spring Mount (Includes Items # 5, 7, 9-11 & F462)	*	37	7701	48 GHS Deck Housing (Includes Items # 35 & 36)	1
6	5704-58	Gearbox and Tube Assembly (Includes Items # 12-21, F124, F136, F179 & F211)	1	38	7775-2	Hitch Pin, RH (Gold) #6	2
	5704-9	HD Gearbox and Tube Assembly (Includes Items # 12-15, 17-21, F136, F179 & F211)	**	39	5727-1	Washer Shim (5/8 ID)	4
7	8678	Spring Mount, Chute	1	Fasteners			
8	8677	Extension Spring (1 x 6-1/16)	1	F002	10-24 Keps Nut		9
9	7726	Chute Hinge (2 x 11)	1	F004	1/4-20 Keps Nut		2
10	7755-1	Chute Lip, Top	1	F005	1/4-20 ESNA Nut		2
11	7755-2	Chute Lip, Bottom	1	F013	3/8-16 Whiz Locknut		6
12	6054	Spline Coupling	4	F018	5/8-18 Hex Nut		2
13	P007	Gasket, Cap (Peerless #788030)	4	F025	10-24 x 3/8 PPHMS		2
14	5066	Gearbox Connector Tube (9-5/16)	1	F029	1/4-20 x 1/2 Hex Bolt		2
15	6733-6	Connecting Shaft (7")	1	F036	1/4-20 x 1/2 SBH Screw		2
16	5706-4	Seal Protector Plate	2	F038	3/8-16 x 1 Hex Bolt		4***
17	5052-1	Gearbox (LH Rotation)	2	F039	3/8-16 x 1-1/4 Hex Bolt		4
	5052-5	HD Gearbox (LH Rotation)	**	F050	1/4 SAE Washer		4
18	5704-1	Gearbox Cover Support	2	F055	5/8 SAE Washer		2
19	7751-16	Tee Gearbox (1.2:1 Ratio)	1	F056	5/8 Split Lock Washer		2
	7751-5	HD Tee Gearbox (1.2:1 Ratio)	**	F059	3/8 Wave Spring Washer		2
20	6733-2	Connecting Shaft (4-1/8)	1	F069	3/32 x 1/2 Cotter Pin		1
21	5061	Gearbox Connector Tube (6-11/16)	1	F087	#10 x 7/8 Fender Washer		2
22	5052-3	1.375 x .750 x .187 Washer	4	F124	10-32 x 3/8 Taptite Machine Screw		6
23	5747-12	Rubber Mat (3 x 6)	2	F129	10-24 x 1/2 PTHMS		3
24	7785-3	48" Gearbox Cover (Includes Item # 23)	1	F136	AN960C416L Washer		16
25	5830	Grease Fitting	1	F179	1/4-20 x 1 Hex Bolt		4
26	8067-13	Shear Pin w/Cotter (Set of 5) (Includes Item # F069)	*	F202	10-24 x 5/8 SHC Screw, GR5 SS		4
				F206	#2 x 3/16 Drive Pin		2
				F211	1/4-20 x 7/8 Hex Bolt		12
				F246	1/4-20 x 1/2 PTHMS		2
				F278	3/8 Split Lock Washer		4***
				F295	3/16 x 1-1/2 Split Spring Pin		1
				F403	1/4-20 x 1/2 PTHMS, SS		2
				F462	3/16 x .468 (+/- .010) Semi-Tube Rivet		4
				F517	Washer 3/8 x 1-1/8 x 1/8		4***
Deck Housing Components				* Service Part Only			
27	8670	Tilt-Up Hook	1	** Item(s) used on the HD version of standard gearboxes. The HD cast iron gearboxes are interchangeable with Standard aluminum gearboxes.			
28	5162-11	Roller Wheel (5" Poly) (Includes Item # F059)	2	*** Used on HD gearbox configuration.			
29	8490	Roller Wheel Axle Bolt	2				
30	NS	Deck Serial Number Plate	1				

DC48 DECK ASSEMBLY

INCL. OPTIONAL HD GEARBOXES

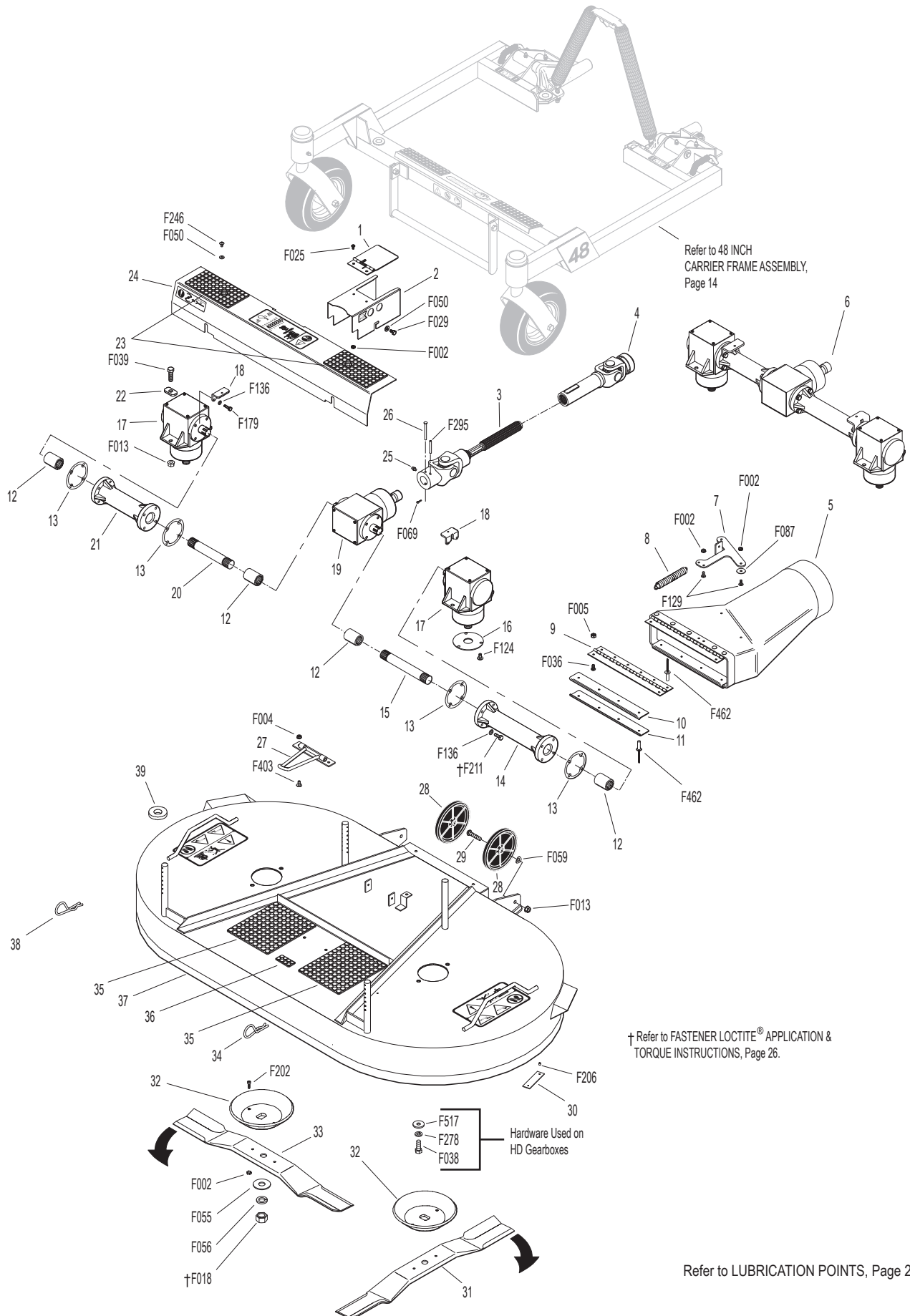

48R INCH COMPLETE CARRIER FRAME ASSEMBLY

ITEM NO.	PART NO.	DESCRIPTION	NO. REQ'D	ITEM NO.	PART NO.	DESCRIPTION	NO. REQ'D
Spring and Pivot Mount Components				Fasteners			
1	5975-3	Cable Tie (50# x 7")	4	F012		3/8-16 Keps Nut	2
2	5744-1	Spring Clip Bracket	1	F014		3/8-16 ESNA Nut	2
3	5743-1	Spring Cover	2	F020		5/16-18 ESNA Nut	2
4	5743-3	Eyebolt (3/8-16 x 2)	2	F047		3/8-16 x 4-1/2 Hex Bolt	2
5	5830	Grease Fitting	8	F055		5/8 SAE Washer	2
6	8667-29	Pivot Mount Adj., LH	1	F068		1/8 x 1 Cotter Pin	2
	8667-3	Pivot Mount Assembly, LH/Adj. (Includes Items # 5, 6, F014, F489 & F520)	*	F084		5/16 Wave Spring Washer	2
7	8667-28	Pivot Mount Adj., RH	1	F098		5/8-18 Slotted Hex Nut	2
	8667-4	Pivot Mount Assembly, RH/Adj. (Includes Items # 5, 7, F014, F489 & F520)	*	F117		Retainer Ring	2
8	5743-6	Extension Spring (1-1/2 x 7-3/4) (Includes Items # 1, F117 & F166)	2	F123		1" External Snap Ring	4
				F166		Retainer Ring	2
				F226		5/16-18 x 7/8 Hex Bolt	2
				F317		3/16 x 1 Split Spring Pin	2
				F335		3/8-16 x 7/8 Set Screw, SS	2
				F336		3/8-16 Jam Nut	2
				F489		Washer 1/4 x 7/8 x .090	2
				F520		1/4-28 x 3/8 Hex Bolt	2
Carrier Frame Components				* Service Part Only			
9	8674-11	Lever, Deck Lock, LH	1	** May be ordered as a kit for dealer installation. Contact your Walker dealer.			
10	7406-1	Handle Grip (Red)	2				
11	8669-5	DGHS48R Lift Handle	1				
12	5748-10	Rubber Mat (1-1/2 x 6)	2				
13	5740-2	Deck Pin Bushing (5/8)	4				
14	8661-7	48R Carrier Frame (Less Pivots) (Includes Item # 12)	1				
	8661-6	48R Carrier Frame w/Forks (Less Pivots) (Includes Items # 12, 21-23, 25, F055, F068 & F098)	*				
15	8674-10	Lever, Deck Lock, RH	1				
Caster Wheel Components							
16	5714-7	Bearing Cap	4				
17	5714-5	Bearing, Caster Wheel	2				
18	5830-3	Grease Fitting (45 Degree)	2				
19	5715-4	Caster Wheel, Pneumatic (8 x 3.00-4) (Includes Items # 16-18)	2				
	5715-10	Tire, Pneumatic (8 x 3.00-4)	*				
	5715-9	Tire Tube, Pneumatic (2.80/2.50-4)	*				
	5715-3	Caster Wheel & Tire/No-Flat (8 x 3.00-4)	**				
	5715-11	Tire, Caster Wheel/No-Flat (8 x 3.00-4)	**				
20	5714-3	Axle Spacer Tube	2				
21	5770-1	Caster Wheel Fork	2				
22	8768-1	Seal (1-3/4 x 1-1/8)	2				
23	8037	Bearing Cone (3/4 ID)	4				
24	8769-1	Bearing Cup (1-3/4 x 1-7/16)	4				
25	8769-9	Dust Cap, Deck Caster	2				

DC48R DECK ASSEMBLY

ITEM NO.	PART NO.	DESCRIPTION	NO. REQ'D	ITEM NO.	PART NO.	DESCRIPTION	NO. REQ'D
Gearbox and Drive Components				29	7705-2	Blade, 25" (LH Rotation)	1
1	8618-1	Cover, PTO Shaft Guard	1		7705-3	48 GHS Blade Set with Hubs (Includes Items # 29-31, F002 & F202)	*
2	8619	PTO Shaft Guard	1	30	5706	Blade Hub & Trash Guard	2
	8618	PTO Shaft Guard Assembly (Includes Items # 1, 2, F002 & F025)	*	31	7705-1	Blade, 25" (RH Rotation)	1
3	7285-15	U-Joint Shaft Assembly, 90 Degree, Spline (Includes Items # 24, F069 & F295)	1	32	7775-1	Hitch Pin, LH (Silver) #6	2
4	7275-16	U-Joint Tube Assembly, Spline	1	33	8735-10	Rubber Mat (5 x 6)	2
5	5794	Discharge Chute W/O Spring Mount (6-1/2 Diameter) (Includes Items # 5, 9-11 & F462)	1	34	8788-1	Rubber Mat (1 x 2)	1
	5794-1	Discharge Chute Assembly with Spring Mount (Includes Items # 5, 7, 9-11 & F462)	*	35	7702-6	48R GHS Deck Housing (Includes Items # 33 & 34)	1
6	5704-83	Gearbox and Tube Assembly (Includes Items # 12-20, F136, F179 & F211)	1	36	7775-2	Hitch Pin, RH (Gold) #6	2
7	8678	Spring Mount, Chute	1	37	5727-1	Washer Shim (5/8 ID)	4
8	8677	Extension Spring (1 x 6-1/16)	1	Fasteners			
9	5726	Chute Hinge (2 x 8)	1	F002	10-24 Keps Nut	9	
10	5755-2	Chute Lip, Top	1	F004	1/4-20 Keps Nut	2	
11	5755-3	Chute Lip, Bottom	1	F005	1/4-20 ESNA Nut	2	
12	6054	Spline Coupling	4	F013	3/8-16 Whiz Locknut	2	
13	P007	Gasket, Cap (Peerless #788030)	4	F018	5/8-18 Hex Nut	2	
14	5066	Gearbox Connector Tube (9-5/16)	1	F025	10-24 x 3/8 PPHMS	2	
15	6733-6	Connecting Shaft (7")	1	F029	1/4-20 x 1/2 Hex Bolt	2	
16	5052-5	HD Gearbox (LH Rotation)	2	F036	1/4-20 x 1/2 SBH Screw	2	
17	5704-1	Gearbox Cover Support	2	F038	3/8-16 x 1 Hex Bolt	4	
18	7751-9	Tee Gearbox (1.2:1 Ratio)	1	F050	1/4 SAE Washer	4	
19	6733-2	Connecting Shaft (4-1/8)	1	F055	5/8 SAE Washer	2	
20	5061	Gearbox Connector Tube (6-11/16)	1	F056	5/8 Split Lock Washer	2	
21	5747-12	Rubber Mat (3 x 6)	2	F059	3/8 Wave Spring Washer	2	
22	7785-3	48" Gearbox Cover (Includes Item # 21)	1	F069	3/32 x 1/2 Cotter Pin	1	
23	5830	Grease Fitting	1	F087	#10 x 7/8 Fender Washer	2	
24	8067-13	Shear Pin w/Cotter (Set of 5) (Includes Item # F069)	*	F129	10-24 x 1/2 PTHMS	3	
Deck Housing Components				F136	AN960C416L Washer	16	
25	8670	Tilt-Up Hook	1	F179	1/4-20 x 1 Hex Bolt	4	
26	5162-11	Roller Wheel (5" Poly) (Includes Item # F059)	2	F202	10-24 x 5/8 SHC Screw, GR5 SS	4	
27	8490	Roller Wheel Axle Bolt	2	F206	#2 x 3/16 Drive Pin	2	
28	NS	Deck Serial Number Plate	1	F211	1/4-20 x 7/8 Hex Bolt	12	
				F246	1/4-20 x 1/2 PTHMS	2	
				F278	3/8 Split Lock Washer	4	
				F295	3/16 x 1-1/2 Split Spring Pin	1	
				F403	1/4-20 x 1/2 PTHMS, SS	2	
				F462	3/16 x .468 (+/- .010) Semi-Tube Rivet	9	
				F517	Washer 3/8 x 1-1/8 x 1/8	4	
				* Service Part Only			

DC48R DECK ASSEMBLY

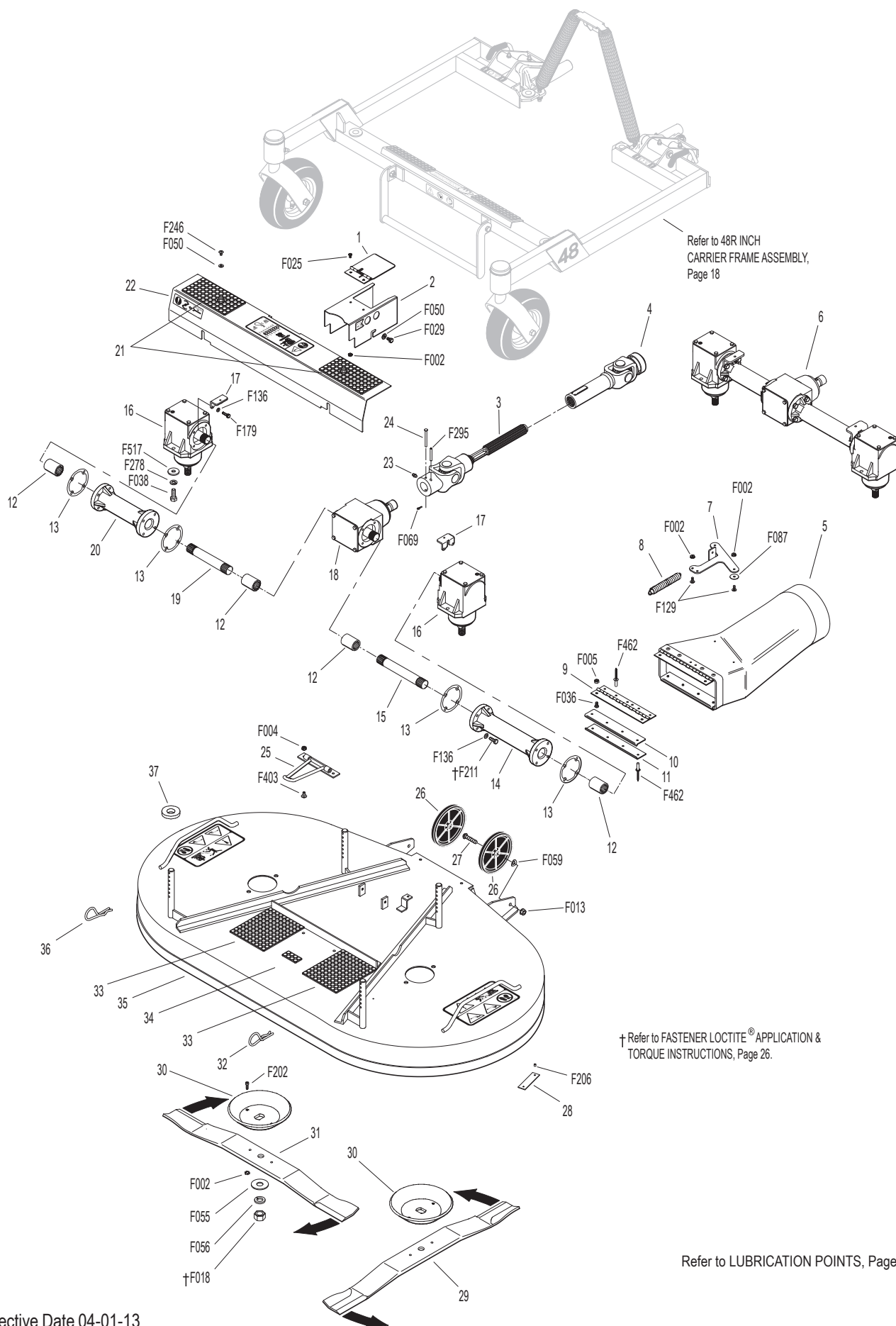

52R INCH COMPLETE CARRIER FRAME ASSEMBLY

ITEM NO.	PART NO.	DESCRIPTION	NO. REQ'D	ITEM NO.	PART NO.	DESCRIPTION	NO. REQ'D
Spring and Pivot Mount Components				Fasteners			
1	5975-3	Cable Tie (50# x 7")	4	F012		3/8-16 Keps Nut	2
2	5744-1	Spring Clip Bracket	1	F014		3/8-16 ESNA Nut	2
3	5743-1	Spring Cover	2	F020		5/16-18 ESNA Nut	2
4	5743-3	Eyebolt (3/8-16 x 2)	2	F047		3/8-16 x 4-1/2 Hex Bolt	2
5	5830	Grease Fitting	8	F055		5/8 SAE Washer	2
6	8667-29	Pivot Mount Adj., LH	1	F068		1/8 x 1 Cotter Pin	2
	8667-3	Pivot Mount Assembly, LH/Adj. (Includes Items # 5, 6, F014, F489 & F520)	*	F084		5/16 Wave Spring Washer	2
7	8667-28	Pivot Mount Adj., RH	1	F098		5/8-18 Slotted Hex Nut	2
	8667-4	Pivot Mount Assembly, RH/Adj. (Includes Items # 5, 7, F014, F489 & F520)	*	F117		Retainer Ring	2
8	5743-6	Extension Spring (1-1/2 x 7-3/4) (Includes Items # 1, F117 & F166)	2	F123		1" External Snap Ring	4
				F166		Retainer Ring	2
				F226		5/16-18 x 7/8 Hex Bolt	2
				F317		3/16 x 1 Split Spring Pin	2
				F335		3/8-16 x 7/8 Set Screw, SS	2
				F336		3/8-16 Jam Nut	2
				F489		Washer 1/4 x 7/8 x .090	2
				F520		1/4-28 x 3/8 Hex Bolt	2
Carrier Frame Components							
9	8674-11	Lever, Deck Lock, LH	1				
10	7406-1	Handle Grip (Red)	2				
11	8669-4	52GHS Lift Handle	1	*		Service Part Only	
12	5748-10	Rubber Mat (1-1/2 x 6)	2				
13	5740-2	Deck Pin Bushing (5/8)	4	**		May be ordered as a kit for dealer installation. Contact your Walker dealer.	
14	8811-3	52GHS Carrier Frame (Includes Item # 12)	1				
	8811-2	52GHS Carrier Frame W/Pivots (Includes Items # 12, 21-25, F055, F068 & F098)	*				
15	8674-10	Lever, Deck Lock, RH	1				
Caster Wheel Components							
16	5714-7	Bearing Cap	4				
17	5714-5	Bearing, Caster Wheel	2				
18	5830-3	Grease Fitting (45 Degree)	2				
19	5715-4	Caster Wheel, Pneumatic (8 x 3.00-4) (Includes Items # 16-18)	2				
	5715-10	Tire, Pneumatic (8 x 3.00-4)	*				
	5715-9	Tire Tube, Pneumatic (2.80/2.50-4)	*				
	5715-3	Caster Wheel & Tire/No-Flat (8 x 3.00-4)	**				
	5715-11	Tire, Caster Wheel/No-Flat (8 x 3.00-4)	**				
20	5714-3	Axle Spacer Tube	2				
21	5770-1	Caster Wheel Fork	2				
22	8768-1	Seal (1-3/4 x 1-1/8)	2				
23	8037	Bearing Cone (3/4 ID)	4				
24	8769-1	Bearing Cup (1-3/4 x 1-7/16)	4				
25	8769-9	Dust Cap, Deck Caster	2				

52R INCH COMPLETE CARRIER FRAME ASSEMBLY

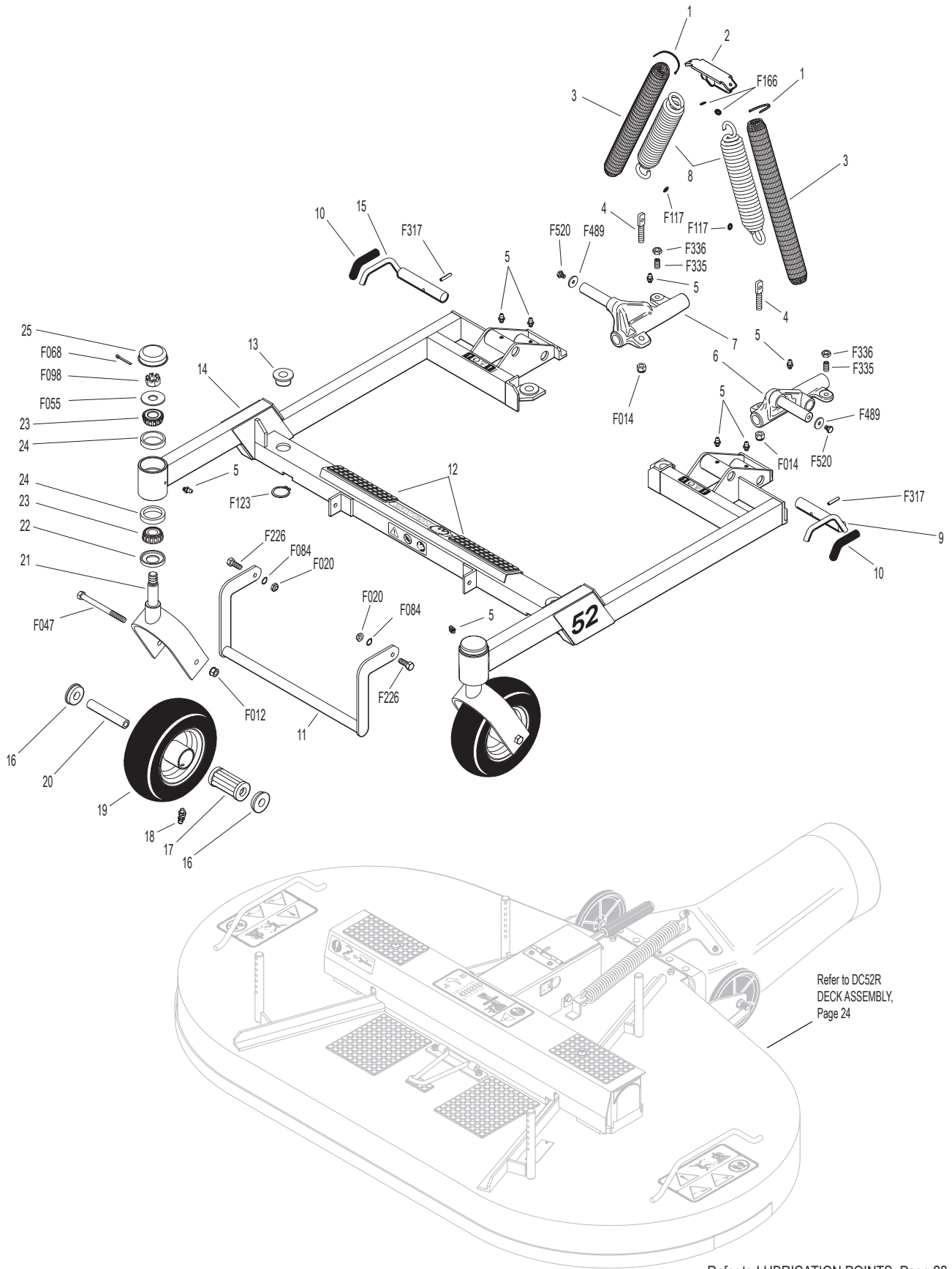

DC52R DECK ASSEMBLY

ITEM NO.	PART NO.	DESCRIPTION	NO. REQ'D	ITEM NO.	PART NO.	DESCRIPTION	NO. REQ'D	
Gearbox and Drive Components				28	NS	Deck Serial Number Plate	1	
1	8618-1	Cover, PTO Shaft Guard	1	29	7705-7	Blade 27" (LH Rotation)	1	
2	8619-3	PTO Shaft Guard, 52GHS	1	30	5706	Blade Hub & Trash Guard	2	
	8618-4	PTO Shaft Guard Assembly/52 (Includes Items # 1, 2, F002 & F025)	*	31	7705-6	Blade 27" (RH Rotation)	1	
3	7285-15	U-Joint Shaft Assembly, 90 Degree, Spline (Includes Items # 24, F069 & F295)	1		7705-9	52 GHS Blade Set W/Hub (Includes Items # 29-31, F002 & F202)	*	
4	7275-16	U-Joint Tube Assembly, Spline	1	32	7775-1	Hitch Pin, LH (Silver) #6	2	
5	5794	Discharge Chute W/O Spring Mount (6-1/2 Diameter) (Includes Items # 5, 9-11 & F462)	1	33	8735-10	Rubber Mat (5 x 6)	2	
	5794-1	Discharge Chute W/Spring Mount (Includes Items # 5, 7, 9-11 & F462)	*	34	8788-1	Rubber Mat (1 x 2)	1	
6	5704-56	52 GHS Gearbox and Tube Assembly (Includes Items # 12-20, F136, F179 & F211)	1	35	8810-2	52 GHS Deck Housing (Includes Items # 33 & 34)	1	
7	8678	Spring Mount, Chute	1	36	7775-2	Hitch Pin, RH (Gold) #6	2	
8	8677	Extension Spring (1 x 6-1/16)	1	37	5727-1	Washer Shim (5/8 ID)	4	
9	5726	Chute Hinge (2 x 8)	1	Fasteners				
10	5755-2	Chute Lip, Top	1		F002	10-24 Keps Nut	9	
11	5755-3	Chute Lip, Bottom	1		F004	1/4-20 Keps Nut	2	
12	6054	Spline Coupling	4		F005	1/4-20 ESNA Nut	2	
13	P007	Gasket, Cap (Peerless #788030)	4		F013	3/8-16 Whiz Locknut	2	
14	5068-3	Connector Tube (10-5/16)	1		F018	5/8-18 Hex Nut	2	
15	6733-10	Connecting Shaft (8-1/32)	1		F025	10-24 x 3/8 PPHMS	2	
16	5052-5	Gearbox, HD (LH Rotation)	2		F029	1/4-20 x 1/2 Hex Bolt	2	
17	5704-1	Gearbox Cover Support	2		F036	1/4-20 x 1/2 SBH Screw	2	
18	7751-9	Tee Gearbox/Shear (1.2:1)	1		F038	3/8-16 x 1 Hex Bolt	4	
19	6733-4	Connecting Shaft (5-5/16)	1		F050	1/4 SAE Washer	4	
20	5065	Connector Tube (7-11/16)	1		F055	5/8 SAE Washer	2	
21	5747-12	Rubber Mat (3 x 6)	2		F056	5/8 Split Lock Washer	2	
22	6786-2	52 GHS Gearbox Cover (Includes Item # 21)	1		F059	3/8 Wave Spring Washer	2	
23	5830	Grease Fitting	1		F069	3/32 x 1/2 Cotter Pin	1	
24	8067-13	Shear Pin w/Cotter (Set of 5) (Includes Item # F069)	*		F087	#10 x 7/8 Fender Washer	2	
Deck Housing Components						F129	10-24 x 1/2 PTHMS	3
25	8670-9	Tilt-Up Hook	1		F136	AN960C416L Washer	16	
26	5162-11	Roller Wheel (5" Poly) (Includes Item # F059)	2		F179	1/4-20 x 1 Hex Bolt	4	
27	8490	Roller Wheel Axle Bolt	2		F202	10-24 x 5/8 SHC Screw, GR5 SS	4	
					F206	#2 x 3/16 Drive Pin	2	
					F211	1/4-20 x 7/8 Hex Bolt	12	
					F246	1/4-20 x 1/2 PTHMS	2	
					F278	3/8 Split Lock Washer	4	
					F295	3/16 x 1-1/2 Split Spring Pin	1	
					F403	1/4-20 x 1/2 PTHMS, SS	2	
					F462	3/16 x .468 (+/- .010) Semi-Tube Rivet	9	
					F517	Washer 3/8 x 1-1/8 x 1/8	4	
				* Service Part Only				

DC52R DECK ASSEMBLY

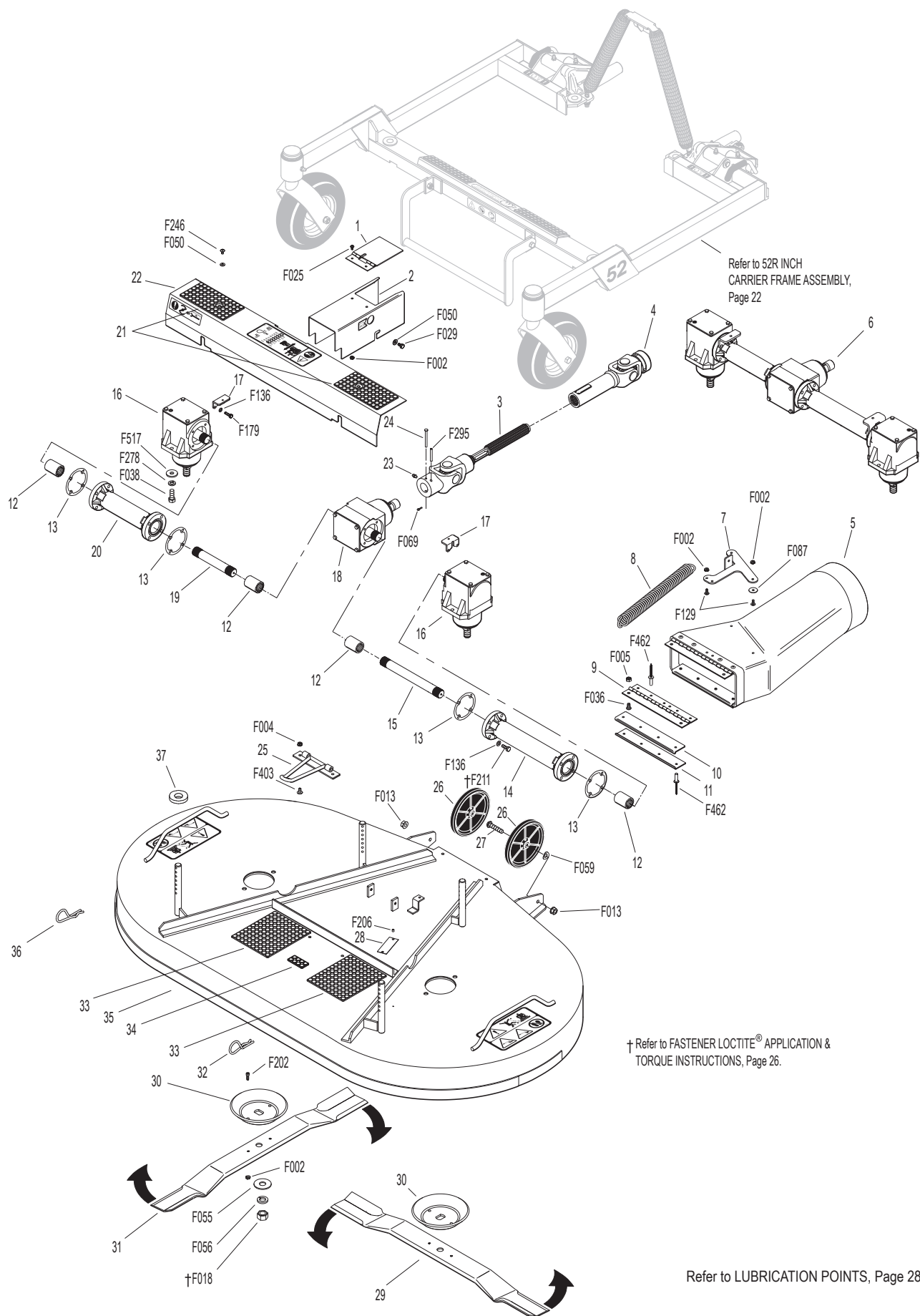

FASTENER LOCTITE® APPLICATION & TORQUE INSTRUCTIONS

ITEM NO.	DESCRIPTION
----------	-------------

DC HD Gear Drive Assemblies

- 1 Apply Loctite® Threadlocker # 242 (Blue) to Item # 1 used on HD Gearbox Connector Tubes. Torque to 115 lb·in. (13.0 N·m).

ITEM NO.	DESCRIPTION
----------	-------------

DC Deck Assembly

- 2 Apply Loctite® Threadlocker # 242 (Blue) to P/N F211 (1/4-20 x 7/8 Hex Bolt, used on Gearbox Connector Tubes) prior to assembly. Torque to 90 lb·in. (10.2 N·m).
- 3 Torque P/N F018 (5/8-18 Hex Nut) to 60 lb·ft (81.4 N·m). **DO NOT** apply Loctite®.

NOTE: Model DC48 is shown here. Refer to individual deck assemblies for exact locations and quantities of items listed above.

FASTENER LOCTITE® APPLICATION & TORQUE INSTRUCTIONS

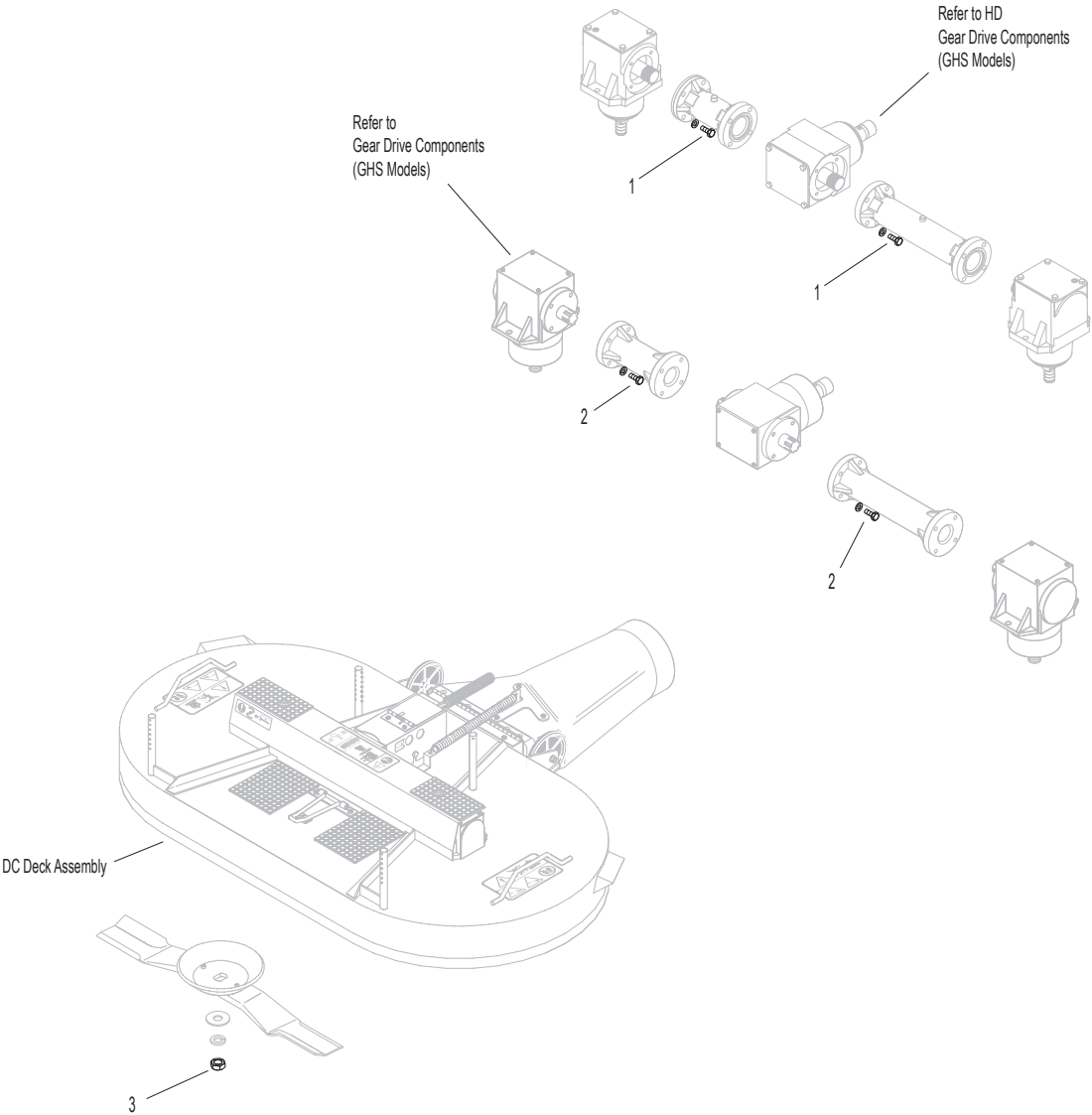

LUBRICATION POINTS

ITEM NO.	LOCATION	LUBRICATION TYPE	NO. PLACES
----------	----------	------------------	------------

ITEM NO.	LOCATION	LUBRICATION TYPE	NO. PLACES
----------	----------	------------------	------------

36", 42", 48" & DC52R Assemblies

1	Deck Caster Wheel Fork Pivot	Grease	2
2	Deck Caster Wheel Bearing	Grease	2
3	Tee Gearbox, Deck	Oil*	1
4	Blade Drive Gearbox	Oil*	2
5	Universal Joint Shaft Assembly	Grease**	1
6	Pivot Assembly, Tilt-Up Deck	Grease	4
7	Deck Support Arm Socket	Grease	2

* Gearboxes are permanently lubricated and sealed requiring no scheduled lubrication. Oil level should be checked only when an oil leak is noted.

** Grease every eight (8) hours.

NOTE: Exact location of some Lubrication Points may vary slightly from those shown in the illustration. Decks shown in the illustration are for reference only; for further information on location of parts not shown here, refer to the parts listings for individual Carrier Frames and Deck Assemblies.

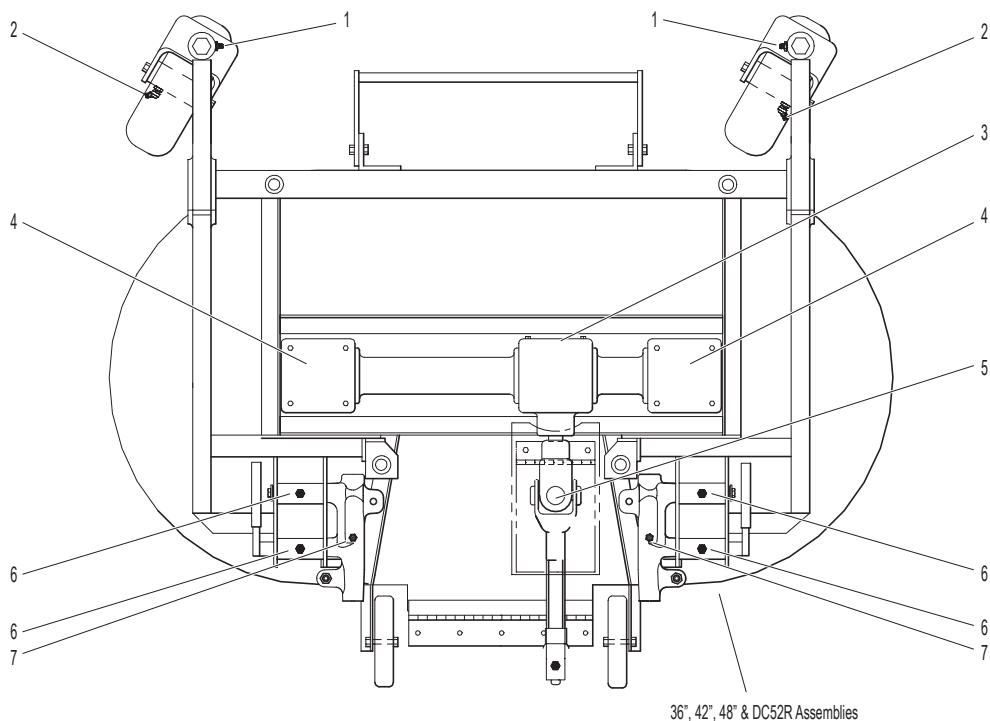

BLADE USAGE CHART

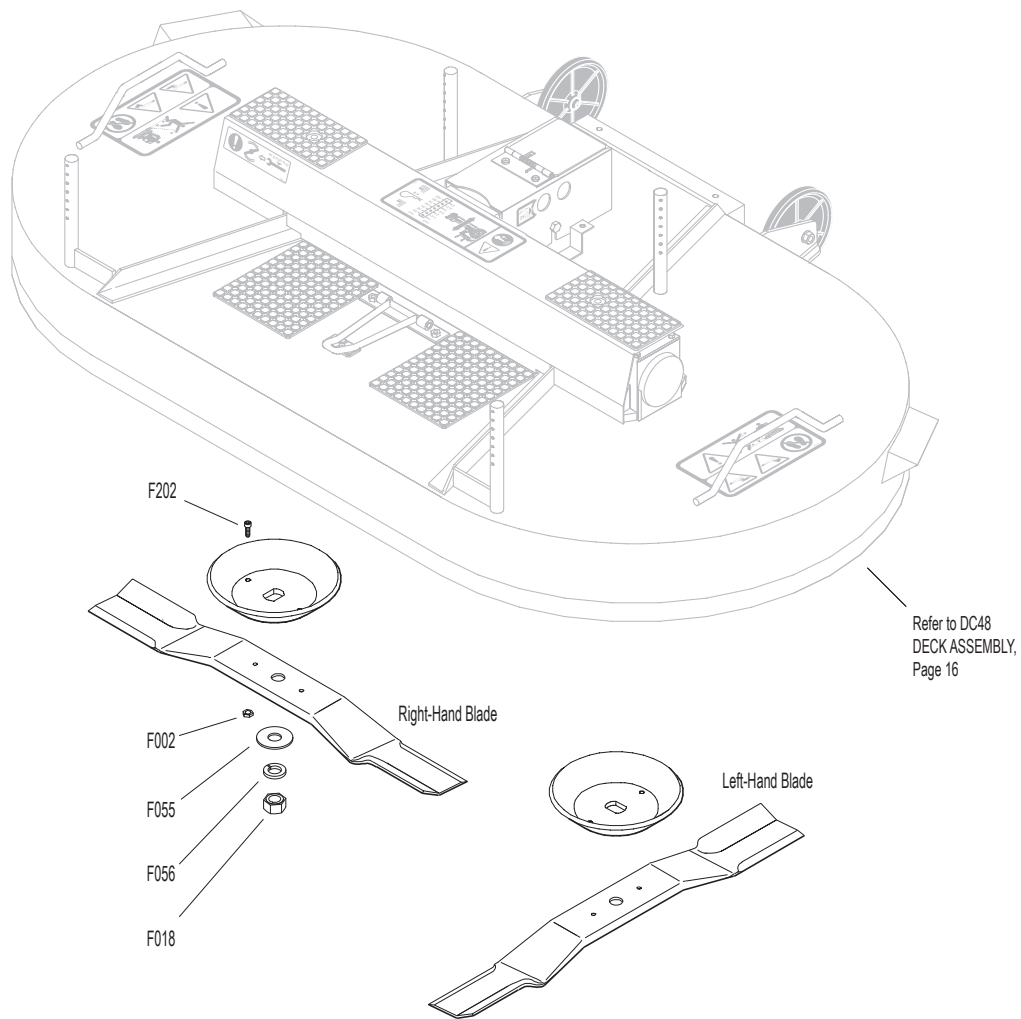

TWO BLADE DECKS	RH BLADE	LH BLADE	BLADE SET
DC36R	5705-36	5705-35	
DC42	5705-4	5705-3	5705-8
DC48	7705-2	7705-1	7705-3
DC48R	7705-1	7705-2	7705-3
DC52R	7705-6	7705-7	7705-9

Right hand and left hand orientated with operator on seat.

All blade sets include 5706 (Blade Hub & Trash Guard), F002 & F202 unless otherwise specified.

OPERATOR'S NOTES

OPERATOR'S NOTES

LIMITED WARRANTY FOR WALKER COMMERCIAL RIDER MOWER

1. WHAT THIS WARRANTY COVERS, AND FOR HOW LONG:

Walker Manufacturing company will, at its option, repair or replace, without charge, any part covered by this warranty which is found to be defective in material and/or workmanship within one (1) year after date of sale to the original retail purchaser unless the product is used for rental purposes, in which case this warranty is limited to ninety (90) days. At Walker's request, customer will make the defective part available for inspection by Walker and/or return the defective part to Walker, transportation charges prepaid. All parts and components of the Walker Mower are covered by this warranty.

2. WHAT THIS WARRANTY DOES NOT COVER:

- A. This warranty does not cover defects caused by depreciation or damage caused by normal wear, accidents, improper maintenance, improper use or abuse of the product, alterations, or failure to follow the instructions contained in the Operator's Manual for operation and maintenance.
- B. The customer shall pay any charges for making service calls and/or for transporting the mower to and from the place where the inspection and/or warranty work is performed.

3. HOW TO OBTAIN SERVICE UNDER THIS WARRANTY:

Warranty service can be arranged by contacting the dealer where you purchased the mower or by contacting Walker Manufacturing Company, 5925 East Harmony Road, Ft. Collins, CO 80528. Proof of the date of purchase may be required to verify warranty coverage.

4. WARRANTY LIMITATION:

- A. **THERE IS NO OTHER EXPRESS WARRANTY. ANY WARRANTY THAT MAY BE IMPLIED FROM THIS PURCHASE INCLUDING MERCHANTABILITY AND FITNESS FOR A PARTICULAR PURPOSE IS HEREBY LIMITED TO THE DURATION OF THIS WARRANTY AND TO THE EXTENT PERMITTED BY LAW ANY AND ALL IMPLIED WARRANTIES ARE EXCLUDED.** Some states do not allow limitations on how long an implied warranty lasts, so the above limitations may not apply to you.
- B. **WALKER WILL NOT BE LIABLE FOR ANY INCIDENTAL, CONSEQUENTIAL, OR SPECIAL DAMAGES AND/OR EXPENSES IN CONNECTION WITH THE PURCHASE OR USE OF THE MOWER.** Some states do not allow the exclusion or limitation of incidental or consequential damages, so the above limitation(s) or exclusion(s) may not apply to you.
- C. Only the warranty expressed in this limited warranty shall apply and no dealer, distributor, or individual is authorized to amend, modify, or extend this warranty in any way. Accordingly, additional statements such as dealer advertising or presentations, whether oral or written, do not constitute warranties by Walker, and should not be relied upon.
- D. This warranty gives you specific legal rights, and you may also have other rights which vary from state to state.



WALKER

WALKER MFG. CO. • 5925 E. HARMONY ROAD, FORT COLLINS, CO 80528 • (970) 221-5614
PRINTED IN USA www.walkermowers.com ©2014 WALKER MFG. CO