

Walker Rider Lawnmowers

ILLUSTRATED PARTS MANUAL

Model MT (23.0 HP)
Model MTL (25.0 HP)
Model MTEFI (26.0 HP)
Model MTLEFI (31.0 HP)

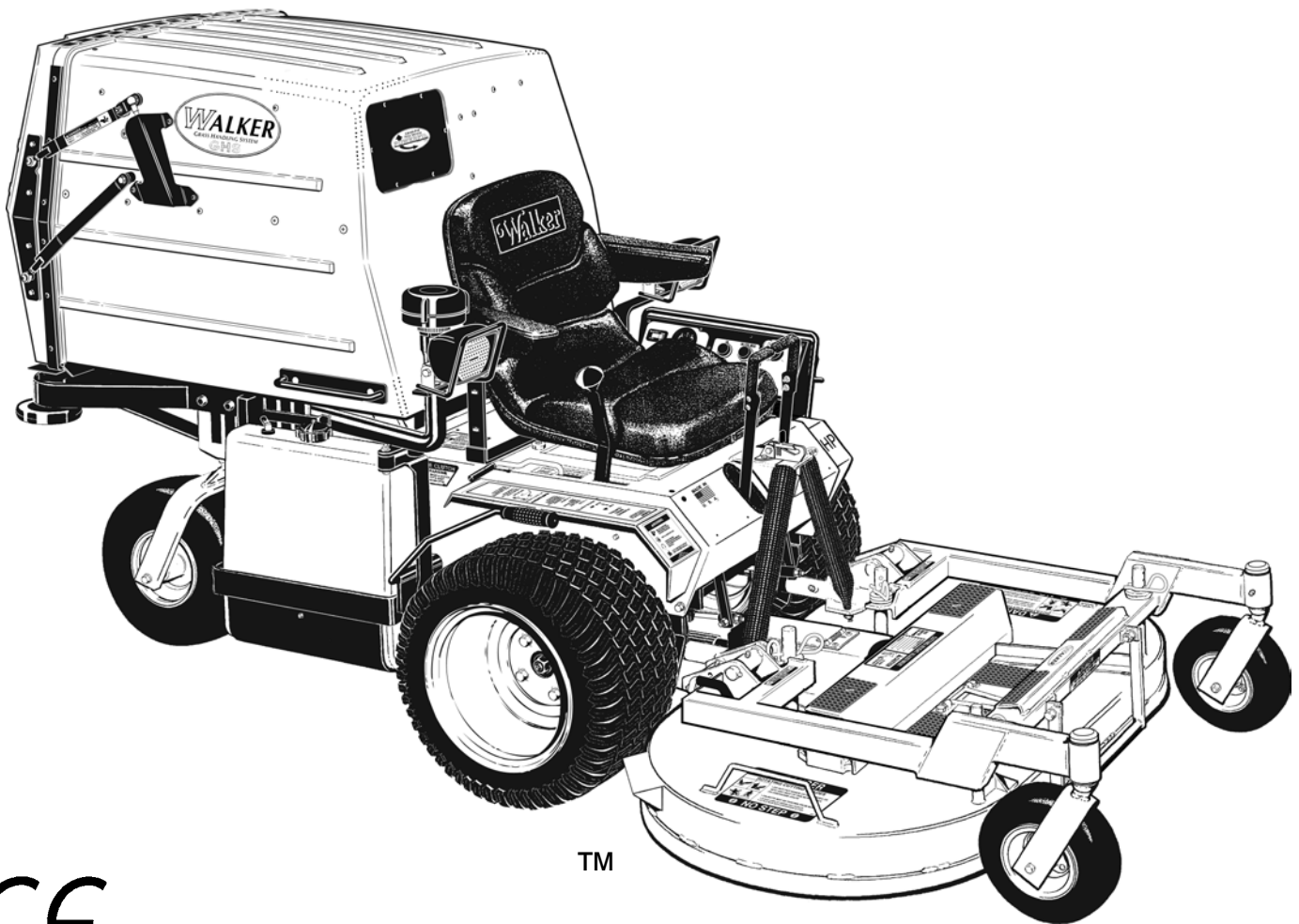

TM

CE

Effective Date:
04-01-09

P/N 8000-15

KEY TO ABBREVIATIONS USED IN THIS MANUAL

<i>Abbreviation</i>	<i>What it Represents</i>
° (Dimension)	Degrees (Angle)
" (Dimension)	inches
(-)	Negative (Polarity)
(+)	Positive (Polarity)
AT	All-Terrain
CCW	Counter-clockwise
Conn	Connector
CW	Clockwise
D	Diameter
DGHS	Deck, Grass Handling System (number refers to size in inches)
DML	Deck, Mulching (number refers to size in inches)
DSD	Deck, Side Discharge (number refers to size in inches)
DU	Garlock (Bearing)
ESNA (Fastener)	Nylon Insert Locknut
FSC	Forward Speed Control
GA	Gauge
gal	gallon
GHS	Grass Handling System
GR (Fastener)	Grade
HP	Horse Power
HT	Heat-Treated
ID	Identification or Inside Diameter
L	Length
LH	Left Hand (orientated with operator on seat)
LP	Low Profile
mm (Dimension)	millimeters
MS (Fastener)	Machine Screw
NS (as part number)	Item is not sold by Walker Manufacturing
OD	Outside Diameter
oz	ounce
PFH (Fastener)	Phillips Flat Head
P/N	Part Number
PPH (Fastener)	Phillips Pan Head
PTH (Fastener)	Phillips Truss Head
PTO	Power Take-Off
QKS	Quick Slide
qt	quart
RH	Right Hand (orientated with operator on seat)
SAE (Fastener)	Society of Automotive Engineers
SBH (Fastener)	Socket Button Head (Bolt)
SD	Side Discharge
SFH (Fastener)	Slotted Flat Head
SHC (Fastener)	Socket Head Cap
SHL (Fastener)	Shoulder (Bolt)
SM (Fastener)	Sheet Metal (Screw)
S/N	Serial Number
Spg	Spring
SQH (Fastener)	Square Head
SS (Fastener)	Stainless Steel
ST (Fastener)	Self-Tapping (Screw)
Term	Terminal
V	Volts

NOTE: In some instances, combinations of abbreviations may be used (e.g. PPHMS - Phillips Pan Head Machine Screw).

Use only genuine **Walker®** replacement parts.

Effective Date 04-01-09

ILLUSTRATED PARTS LIST

<i>Section of Mower Covered</i>	<i>Page</i>	<i>Section of Mower Covered</i>	<i>Page</i>
Decals		Electrical Components	
Tractor Decals	2	Electrical Assembly	
Body / Chassis Assemblies		(MT)	54
Body / Chassis Assembly		(MTL)	56
(GHS Models) MT/MTEFI.....	4	(MTEFI).....	58
(GHS Models) MTL/MTLEFI.....	6	(MTLEFI).....	60
Rear Body Assembly		Electrical Assemblies	
(GHS Models) MT/MTEFI.....	8	(GHS 10.0 / 7.0 Bushel Components).....	62
(GHS Models) MTL/MTLEFI.....	10	Electrical Connectors.....	64
Body Assembly		Options and Kits	
(SD Models) MT/MTEFI	12	Power Deck Lift Kit.....	66
(SD Models) MTL/MTLEFI	14	Armrest Kit / Touch-Up Paint / Comfort Seat Kit	68
Tractor Components		Suspension Seat Kit.....	70
Main Component Power Transmission		Light Kit / Cold Start Kit / Speed Up Kit.....	72
(GHS Models)	16	Power Dump Kit	
(SD Models)	18	(10.0 Bushel GHS Models Only).....	74
Engine Group		(7.0 Bushel GHS Models Only).....	76
(MT)	20	Hi-Dump Kit	78
(MTL)	22	Hi-Dump Kit - Hydraulic.....	80
(MTEFI).....	24	No Catch Deflector Kit / Tail Weight Kit /	
(MTLEFI).....	26	Spread Tail Wheel Axle Kit	82
Radiator Group (MTL/MTLEFI).....	28	Tail Wheel Lock Kit / Blower Lockout Kit /	
Hydrostatic Ground Drive Assemblies.....	30	Case-Hardened Blower	84
Steering Control Assemblies.....	32	Wide Tail Wheel / All-Terrain Tire Kit &	
Throttle & Choke Control Assembly	34	Tire Chain Set	86
Parking Brake Assembly	36	Maintenance	
GHS Group	38	Lubrication Points	88
GHS Powerfil® Assemblies (10.0 / 7.0).....	40	Wiring Schematic	
GHS 10.0 Bushel Catcher Assembly.....	42	(MT)	90
GHS 7.0 Bushel Catcher &		(MTL)	91
Exhaust Deflector Assemblies	44	(MTEFI).....	92
Instrument Panel Assembly		(MTLEFI).....	94
(MT)	46	Operator's Notes	96
(MTL)	48	Warranty	
(MTEFI).....	50	Limited Warranty	97
(MTLEFI).....	52		

TRACTOR DECALS

ITEM NO.	PART NO.	DESCRIPTION	LOCATION	NO. REQ'D. GHS	NO. REQ'D SD
Walker Product and Operation Decals					
1	7802	RH Fender	Body, RH Side Near Seat	1	1
2	5856	Made in USA	Body	1	1
3	5803	Walker Manufacturing Logo	Body	1	1
4	5813-1	Powerfil®	7.0 / 10.0 Bushel Catcher, Front	1	0
5	5801	GHS	7.0 / 10.0 Bushel Catcher (one on each side)	2	0
6	5800	Walker Mower (4 x 7-1/2)	Utility Bed (one on each side)	0	2
7	5806	Blade Clutch	Body, RH Side	1	1
Danger Decals Warning Decals Caution Decals					
8	5804	Danger, Rotating Blower Blades	Body, Near Body Chute	1	0
9	7818	Warning, Read Manual	Body	1	1
10	6810	Danger, Engine Exhaust	Engine	1	1
11	5868	Danger, Pinch Point	7.0 / 10.0 Bushel Catcher Mounting Frame Assembly (one on each side)	2	0
12	5844-2	Warning, Electric System	Battery Hold-Down Bar	1**	1**
13	5810-3	Decal, Hydro Warning	Bridge Assembly and LH Gear Axle Drive Assembly	2	2
Maintenance Decals					
14	7809	Parking Brake	Body, RH Side below Seat	1	1
15	8400-6	Body Latch Decal	Body, RH Side below Seat	1	1
16	7819	Throttle	Body, LH Side	1	1
17	8819	Choke	Body, LH Side	1	1
18	5855	Important, Engine Cooling	Engine	1	1
19	NS	Sealed Reservoir	Hydrostatic Drives (one on each)	2	2
20	5810-1	Axle Oil Level	Gear Axle Drive Assemblies (one on each)	2	2
21	5819	Blower Maintenance	Blower Housing	1	0
22	6875	PTO Alignment Arrow	Universal Joint Tube Assembly	1	1
23	7827	Oil Level	Jackshaft Support	1	1
24	5874	Push to Release	7.0 Bushel Catcher Safety Latch	1***	0
25	8825	Front Body Closure	Rear Cross Member, Body	1	1
26	8821-1	23 HP	Body	1*	1*
	8822	25 HP	Body	1*	1*
	8822-10	26 HP	Body	1*	1*
	8822-12	31 HP	Body	1*	1*
27	5869	Removable Screen	7.0 / 10.0 Bushel Catcher Removable Screen	1	0
Option Decals (applied only to units with corresponding Options installed)					
28	7633	Power Dump Switch	Body	1	0
29	8555	Tail Lock Switch	FSC Lever Assembly - Switch Mount Bracket	1	1
30	8654	Power Deck Lift Switch	Body, RH Side	1	1
	8500-8	No Catch Deflector	7.0 Bushel No Catch Deflector, LH Side (Refer to 7.0 Bushel No Catch Deflector Kit Listing)	1***	0

* 23 HP Decal is Standard. 25 HP Decal furnished only with 25 HP Engine Upgrade Option.
26 HP Decal furnished only with Optional 26 HP EFI Engine. 31 HP Decal furnished only with MTLEFI Option.

** Decal furnished only with fuel-injected models.

*** Item used on 7.0 models only

NOTE: All parts requiring decals are shipped with decals applied.

Use only genuine **Walker®** replacement parts.

Effective Date 04-01-09

TRACTOR DECALS

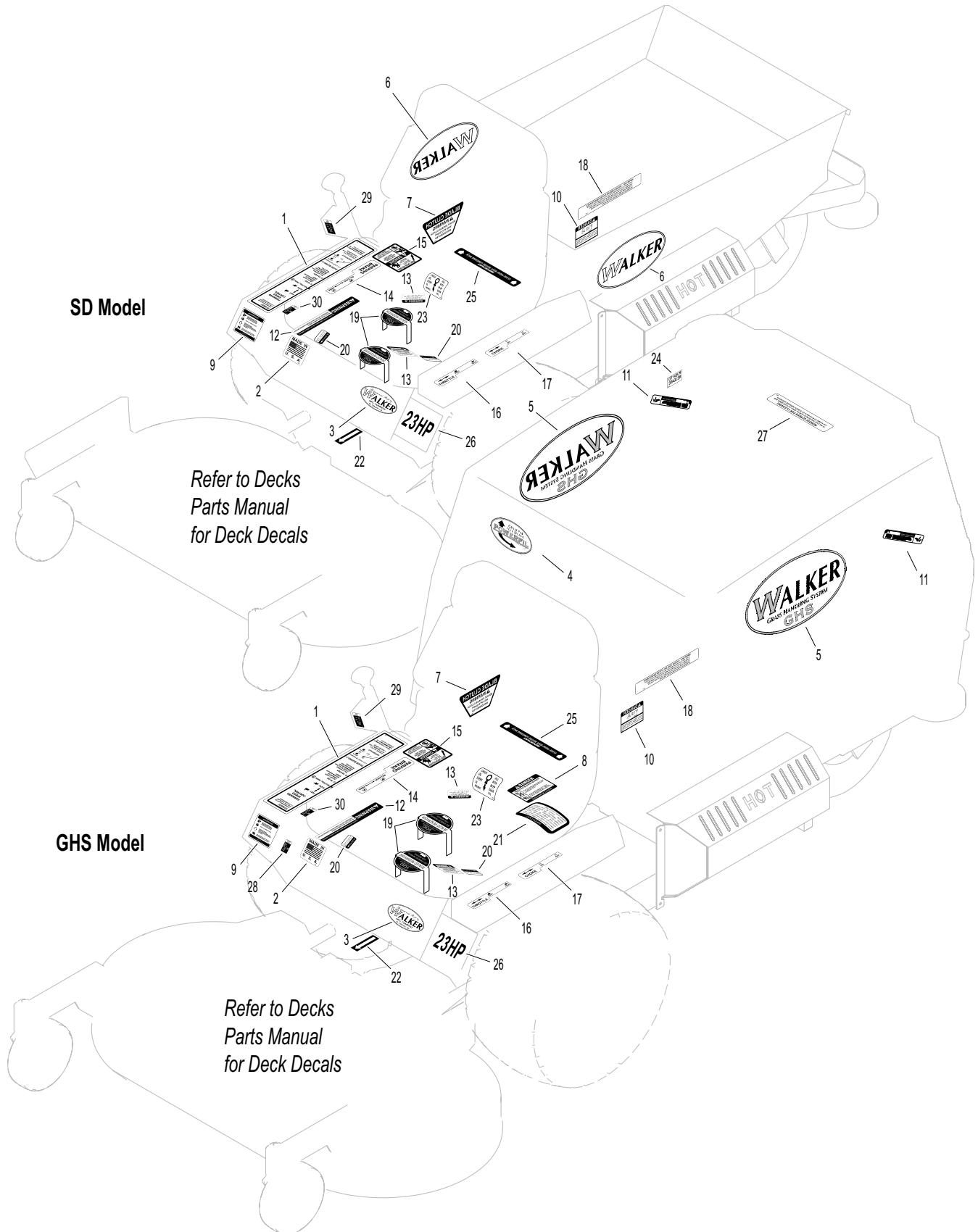

BODY / CHASSIS ASSEMBLY (GHS MODELS) MT/MTEFI

ITEM NO.	PART NO.	DESCRIPTION	NO. REQ'D	ITEM NO.	PART NO.	DESCRIPTION	NO. REQ'D
Seat Assembly				46	8038-1	Spacer, Tail Wheel Axle	2
1	5103	Seat	1	47	8037	Bearing Cone (3/4 ID)	4
2	7203	Seat Spring Plate	1	48	8035	Tail Wheel & Tire Assembly (13 x 5.00-6) (With Bearing Race)	2
3	7223-1	Compression Spring	2		7035-1	Tail Wheel Tire (13 x 5.00-6)	**
4	7845	Rubber Bumper (1.375 OD x .63)	2		8036	Wheel & Hub (6 x 3.25) (Includes Item # 43 & Bearing Race)	**
5	7846	Washer (3/8 ID x 1-1/4 OD x 1/8)	2		8037-2	Bearing Race	**
6	7204	Shoulder Bolt, Seat Mount	2	49	8768-2	Seal, Reverse Lip	2
7	7440-5	Shock Mount (1-1/4 x 3/4)	2	50	8038	Tail Wheel Axle (3/4 x 10-3/8)	1
Rear Bumper Assembly (GHS Models Only)*				51	7070	Wheel & Tire Assembly (18 x 9.5-8)	2
8	7516	7.0 / 10.0 Rear Bumper	1		7070-1	Drive Tire (18 x 9.5-8)	**
9	7516-5	Catcher Pivot Bushing	2		5070-4	Wide Wheel (8 x 7)	**
10	5162	Roller Wheel (5" Rubber)	2	52	8300-14	Chassis Frame (T/5.0 gal.)	1
11	7517-2	Catcher Pivot Plate	2		8300-16	Chassis Frame (EFI/5.0 gal.)	1
Body Assembly				Fasteners			
12	NS	Body ID Plate	1		F002	10-24 Keps Nut	2
13	5989-12	Dome Plug (3/16)	1		F004	1/4-20 Keps Nut	2
14	5989-10	Dome Plug (9/16)	1		F005	1/4-20 ESNA Nut	1
15	5845	Rubber Bumper (1.50 OD x 1.25)	4		F009	5/16-18 Whiz Locknut	12
16	8118	Heat Deflector	1		F012	3/8-16 Keps Nut	8
17	7422	Panel Guard	1		F013	3/8-16 Whiz Locknut	2
18	5989-4	Dome Plug (3/8)	4		F014	3/8-16 ESNA Nut	4
19	5989-3	Dome Plug (5/16)	2		F020	5/16-18 ESNA Nut	1
20	7146	13mm Ball Stud	2		F025	10-24 x 3/8 PPHMS	2
21	7844	Rubber Bumper (1.25 OD x .25)	1		F029	1/4-20 x 1/2 Hex Bolt	2
22	7147	Spring Clip	2		F031	1/4-20 x 5/8 Hex Bolt	1
23	7145	Gas Spring Assembly (Includes Items # 20 & 22)	1		F034	5/16-18 x 3/4 Hex Bolt	2
24	7222	Extension Spring (1/4 x 3)	1		F038	3/8-16 x 1 Hex Bolt	6
25	7383-3	Body Latch Hook (2-1/2 Side Bars)	1		F040	3/8-16 x 1-1/2 Hex Bolt	2
26	7854	Plastic Tip, Red	1		F042	3/8-16 x 2-1/4 Hex Bolt	2
27	5989-9	Dome Plug (1/4)	8		F050	1/4 SAE Washer	1
28	8100-4	Front Body / MT	1		F051	3/8 SAE Washer	2
	8100-5	Front Body / MTEFI	1		F059	3/8 Wave Spring Washer	2
29	5180	Edge Molding, Lever Opening	2		F093	5/16-18 x 1 Hex Bolt	1
30	5989-55	Dome Plug (1/2)	1		F151	3/8-16 x 7/8 Hex Bolt	2
31	5989-5	Dome Plug (7/16)	1		F157	1/2-20 x 1-1/4 Wheel Lug Bolt	8
Tilt-Up Latch Assembly***					F205	5/16-18 x 1/4 Set Screw, Knurl Point	2
32	5847	Plastic Tip	1		F206	#2 x 3/16 Drive Pin	2
33	5744-20	Spring Arm, Tilt-Up Latch	1		F218	7/16 Split Lock Washer	2
34	5744-10	Spring Pivot Bushing	1		F219	7/16-14 x 1-1/4 Hex Bolt	2
35	5744-15	Compression Spring (3/8 x 5/8)	1		F227	3/8 x 1-1/4 x 1/8 Plastic Washer	2
36	5744-13	Mount Angle, LH	1		F241	.375 x .875 x .10 Washer	4
37	5744-12	Hook, Tilt-Up Latch	1		F341	Coil Roll Pin (7/64 x 9/16)	1
38	5744-14	Mount Angle, RH	1		F342	5/16 Conical Washer	2
Chassis Assembly					F413	5/16-24 x 5/16 Set Screw	2
39	5267-1	Retainer Collar (1") (Includes Item # F413)	1	* Rear Bumper Assembly for SD Models is not shown here. Refer to BODY ASSEMBLY (SD MODELS) MT/MTEFI , Page 12.			
40	5270-1	Pivot Bearing	2	** Service Part Only			
41	5842-1	Washer, Axle Spacer	1	*** Complete Tilt-Up Latch Assembly Kit available by ordering kit # 5747.			
42	7420	Tail Wheel Fork	1				
43	5830-3	Grease Fitting (45 Degree)	2				
44	8039	Nut, Tail Wheel Axle	2				
45	8037-1	Seal, Outer (1-3/4 x 1-1/8)	2				

Use only genuine **Walker®** replacement parts.

Effective Date 04-01-09

BODY / CHASSIS ASSEMBLY (GHS MODELS) MT/MTEFI

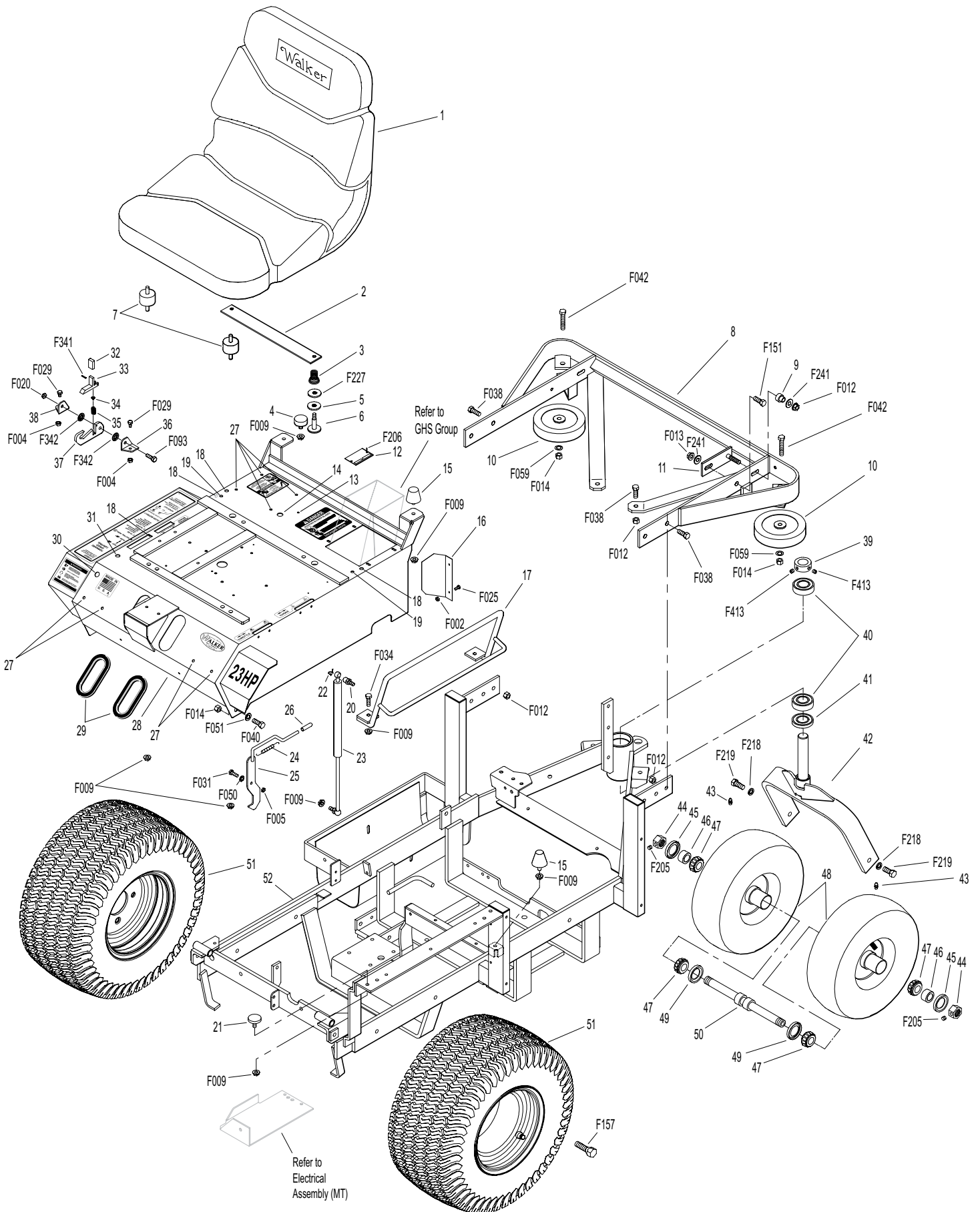

Effective Date 04-01-09

Use only genuine Walker® replacement parts.

BODY / CHASSIS ASSEMBLY (GHS MODELS) MTL/MTLEFI

ITEM NO.	PART NO.	DESCRIPTION	NO. REQ'D	ITEM NO.	PART NO.	DESCRIPTION	NO. REQ'D
Seat Assembly				46	8035	Tail Wheel & Tire Assembly (13 x 5.00-6) (With Bearing Race)	2
1	6103-14	Suspension Seat	1				
2	6103-35	Suspension Seat Mount	2	7035-1		Tail Wheel Tire (13 x 5.00-6)	**
3	7440-7	Shock Mount	4	8036		Wheel & Hub (6 x 3.25) (Includes Item # 41 & Bearing Race)	**
4	6105-1	Shoulder Washer	2		8037-2	Bearing Race	**
Rear Bumper Assembly (GHS Models Only)*				47	8768-2	Seal, Reverse Lip	2
5	7516-7	7.0 / 10.0 Rear Bumper	1	48	8038	Tail Wheel Axle (3/4 x 10-3/8)	1
6	7516-5	Catcher Pivot Bushing	2	49	7070	Wheel & Tire Assembly (18 x 9.5-8)	2
7	5162	Roller Wheel (5" Rubber)	2		7070-1	Drive Tire (18 x 9.5-8)	**
8	7517-2	Catcher Pivot Plate	2		5070-4	Wide Wheel (8 x 7)	**
Body Assembly				50	8300-17	Chassis Frame	1
9	8531-4	Body Grass Shield (Includes Items # 10, 11 & F079)	1	Fasteners			
10	8532	Flap, Rear Body Shield	1	F002		10-24 Keps Nut	3
11	8532-1	Backup Plate	1	F004		1/4-20 Keps Nut	5
12	7833-2	Cable Clamp (1 x 1/4)	1	F005		1/4-20 ESNA Nut	1
13	5977-3	Grommet (9/16)	1	F009		5/16-18 Whiz Locknut	14
14	NS	Body ID Plate	1	F012		3/8-16 Keps Nut	8
15	5845	Rubber Bumper (1.50 OD x 1.25)	4	F013		3/8-16 Whiz Locknut	2
16	8118	Heat Deflector	1	F014		3/8-16 ESNA Nut	4
17	7422	Panel Guard	1	F020		5/16-18 ESNA Nut	1
18	5989-4	Dome Plug (3/8)	4	F025		10-24 x 3/8 PPHMS	3
19	5989-3	Dome Plug (5/16)	2	F029		1/4-20 x 1/2 Hex Bolt	2
20	6105-3	Harness Clip	2	F031		1/4-20 x 5/8 Hex Bolt	4
21	7844	Rubber Bumper (1.25 OD x .25)	1	F034		5/16-18 x 3/4 Hex Bolt	2
22	7222	Extension Spring (1/4 x 3)	1	F038		3/8-16 x 1 Hex Bolt	6
23	7383-3	Body Latch Hook (2-1/2 Side Bars)	1	F040		3/8-16 x 1-1/2 Hex Bolt	2
24	7854	Plastic Tip, Red	1	F042		3/8-16 x 2-1/4 Hex Bolt	2
25	5989-9	Dome Plug (1/4)	8	F050		1/4 SAE Washer	4
26	8100-6	Front Body / MTL	1	F051		3/8 SAE Washer	2
	8100-7	Front Body / MTLEFI	1	F059		3/8 Wave Spring Washer	2
27	5180	Edge Molding, Lever Opening	2	F079		A/A66D Aluminum Pop Rivet	5
28	5989-55	Dome Plug (1/2)	1	F091		5/16-18 x 5/8 Hex Bolt	4
29	5989-5	Dome Plug (7/16)	1	F093		5/16-18 x 1 Hex Bolt	1
Tilt-Up Latch Assembly***				F151		3/8-16 x 7/8 Hex Bolt	2
30	5847	Plastic Tip	1	F157		1/2-20 x 1-1/4 Wheel Lug Bolt	8
31	5744-20	Spring Arm, Tilt-Up Latch	1	F191		3/8 x 1-1/2 x 3/16 Washer	2
32	5744-10	Spring Pivot Bushing	1	F205		5/16-18 x 1/4 Set Screw, Knurl Point	2
33	5744-15	Compression Spring (3/8 x 5/8)	1	F206		#2 x 3/16 Drive Pin	2
34	5744-13	Mount Angle, LH	1	F218		7/16 Split Lock Washer	2
35	5744-12	Hook, Tilt-Up Latch	1	F219		7/16-14 x 1-1/4 Hex Bolt	2
36	5744-14	Mount Angle, RH	1	F241		.375 x .875 x .10 Washer	4
Chassis Assembly				F341		Coil Roll Pin (7/64 x 9/16)	1
37	5267-1	Retainer Collar (1") (Includes Item # F413)	1	F342		5/16 Conical Washer	2
38	5270-1	Pivot Bearing	2	F413		5/16-24 x 5/16 Set Screw	2
39	5842-1	Washer, Axle Spacer	1	F429		5/16-18 x 1/2 SFH Screw	4
40	7420	Tail Wheel Fork	1	* Rear Bumper Assembly for SD Models is not shown here. Refer to BODY ASSEMBLY (SD MODELS) MTL/MTLEFI , Page 14.			
41	5830-3	Grease Fitting (45 Degree)	2	** Service Part Only			
42	8039	Nut, Tail Wheel Axle	2	*** Complete Tilt-Up Latch Assembly Kit available by ordering kit # 5747.			
43	8037-1	Seal, Outer (1-3/4 x 1-1/8)	2				
44	8038-1	Spacer, Tail Wheel Axle	2				
45	8037	Bearing Cone (3/4 ID)	4				

Use only genuine **Walker®** replacement parts.

Effective Date 04-01-09

BODY / CHASSIS ASSEMBLY (GHS MODELS) MTL/MTLEFI

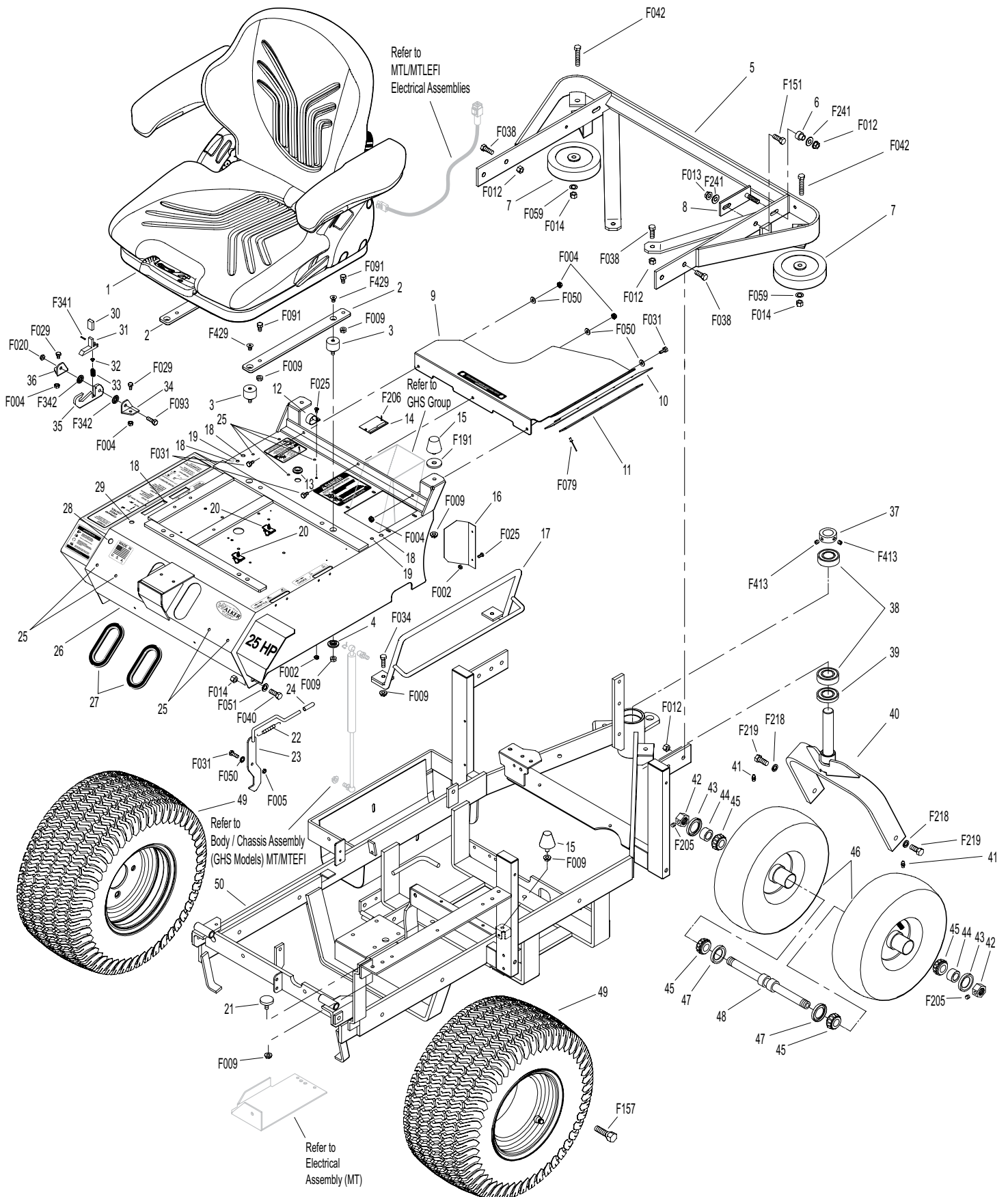

Effective Date 04-01-09

Use only genuine **Walker®** replacement parts.

REAR BODY ASSEMBLY (GHS MODELS) MT/MTEFI

ITEM NO.	PART NO.	DESCRIPTION	NO. REQ'D	ITEM NO.	PART NO.	DESCRIPTION	NO. REQ'D
Rear Body Assembly (GHS Models)				Fasteners			
1	7190-3	Insulation Foam Pad (5 x 20)	1	F002		10-24 Keps Nut	14
2	8082	Heat Shield	1	F004		1/4-20 Keps Nut	5
3	8515-10	Catcher Reinforcing Plate	2	F009		5/16-18 Whiz Locknut	2
4	8615-3	Catcher Support Frame, 10.0	1	F025		10-24 x 3/8 PPHMS	8
5	7190-2	Insulation Foam Pad, RH	1	F026		10-24 x 1/2 PPHMS	5
6	7190-1	Insulation Foam Pad, LH	1	F027		10-24 x 5/8 PPHMS	1
7	5832	Cable Clamp (1/2)	1	F031		1/4-20 x 5/8 Hex Bolt	2
8	7145	Gas Spring Assembly (Includes Items # 10 & 11)	1	F032		1/4-20 x 3/4 Hex Bolt	1
9	8389-2	Splash Guard with Mat	1	F085		3/16 Rivet Backup Washer	2
10	7147	Spring Clip	2	F178		1/4 x 1 Fender Washer	1
11	7146	13mm Ball Stud	2	F390		1/4-20 x 7/8 Carriage Bolt	2
12	8389-12	Rubber Mat (3 x 3)	1	NOTE: Rear Bumper Assembly for GHS Models is not shown here. Refer to BODY / CHASSIS ASSEMBLY (GHS MODELS) MT/MTEFI , Page 4.			
13	8105-1	Rear Body Panel	1				

REAR BODY ASSEMBLY (GHS MODELS) MTL/MTLEFI

ITEM NO.	PART NO.	DESCRIPTION	NO. REQ'D	ITEM NO.	PART NO.	DESCRIPTION	NO. REQ'D
Rear Body Assembly (GHS Models)				Fasteners			
1	8515-10	Catcher Reinforcing Plate	2	F002		10-24 Keps Nut	12
2	8615-4	Catcher Support Frame, 10.0	1	F004		1/4-20 Keps Nut	5
3	7190-2	Insulation Foam Pad, RH	1	F009		5/16-18 Whiz Locknut	2
4	7190-1	Insulation Foam Pad, LH	1	F025		10-24 x 3/8 PPHMS	5
5	5832	Cable Clamp (1/2)	1	F026		10-24 x 1/2 PPHMS	7
6	7145	Gas Spring Assembly (Includes Items # 8 & 9)	1	F027		10-24 x 5/8 PPHMS	1
7	8389-3	Splash Guard	1	F031		1/4-20 x 5/8 Hex Bolt	2
8	7147	Spring Clip	2	F032		1/4-20 x 3/4 Hex Bolt	1
9	7146	13mm Ball Stud	2	F085		3/16 Rivet Backup Washer	3
10	8082-2	Heat Shield, 10.0	1	F178		1/4 x 1 Fender Washer	1
11	7190-4	Insulation Foam Pad/GHS	1	F390		1/4-20 x 7/8 Carriage Bolt	2
12	8105-16	Rear Body Panel	1				

NOTE: Rear Bumper Assembly for GHS Models is not shown here. Refer to **BODY / CHASSIS ASSEMBLY (GHS MODELS) MTL/MTLEFI**, Page 6.

REAR BODY ASSEMBLY (GHS MODELS) MTL/MTLEFI

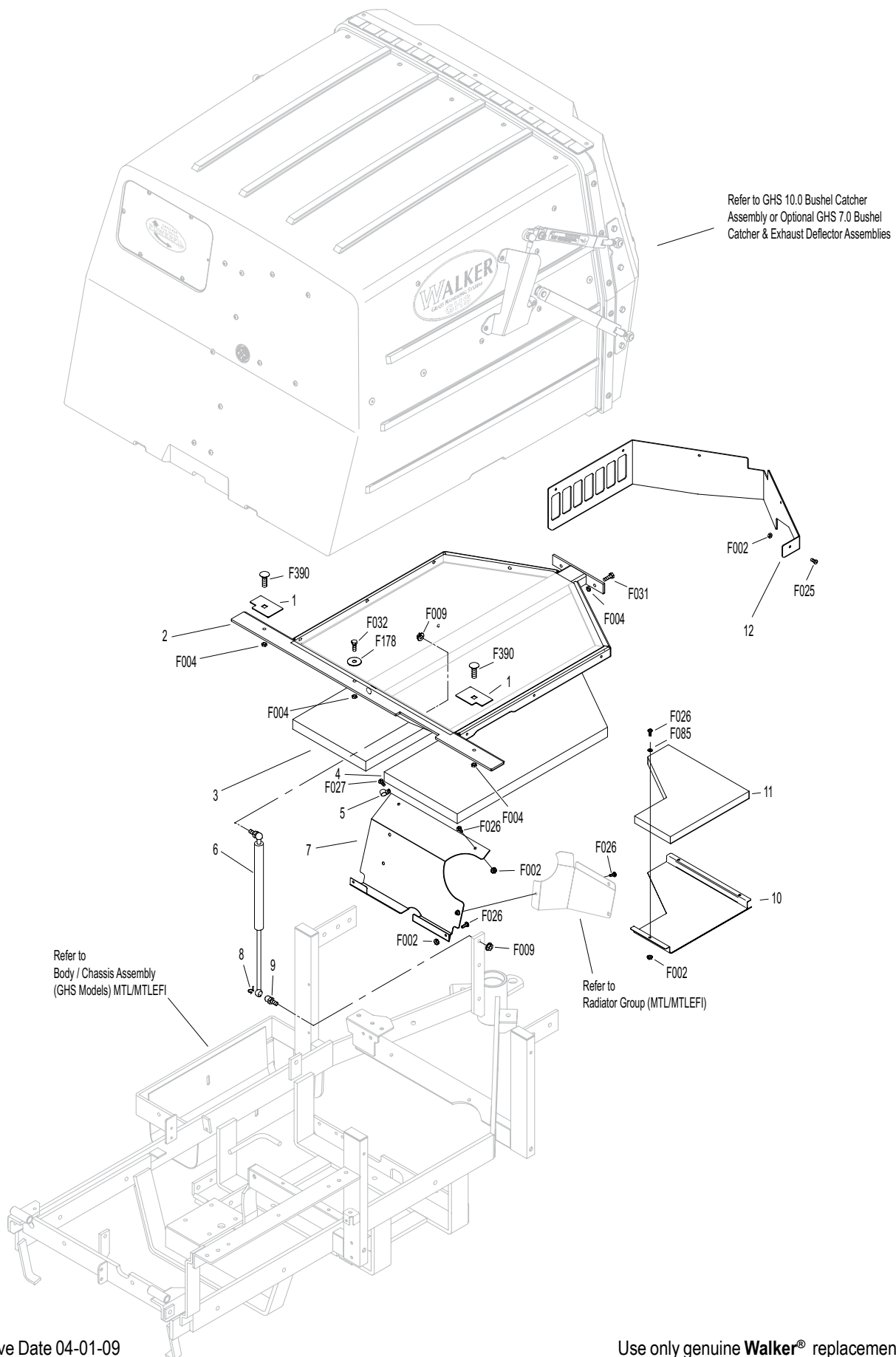

Effective Date 04-01-09

Use only genuine **Walker**® replacement parts.

BODY ASSEMBLY (SD MODELS) MT/MTEFI

ITEM NO.	PART NO.	DESCRIPTION	NO. REQ'D	ITEM NO.	PART NO.	DESCRIPTION	NO. REQ'D
Utility Bed Assembly				Fasteners			
1	8650-10	Bed Liner (21.5 x 27.5)	1	F002		10-24 Keps Nut	16
2	8650-2	Utility Bed (Includes Item # 1)	1	F009		5/16-18 Whiz Locknut	2
3	7190-2	Insulation Foam Pad, RH	1	F012		3/8-16 Keps Nut	6
4	7190-1	Insulation Foam Pad, LH	1	F013		3/8-16 Whiz Locknut	4
Rear Bumper Assembly (SD Models)				F014		3/8-16 ESNA Nut	2
5	7153-3	Cover Plate	1	F025		10-24 x 3/8 PPHMS	8
6	7145	Gas Spring Assembly (Includes Items # 7 & 8)	1	F026		10-24 x 1/2 PPHMS	3
7	7147	Spring Clip	2	F027		10-24 x 5/8 PPHMS	1
8	7146	13mm Ball Stud	2	F038		3/8-16 x 1 Hex Bolt	6
9	7521	Rear Bumper	1	F040		3/8-16 x 1-1/2 Hex Bolt	2
10	5162	Roller Wheel (5" Rubber)	2	F042		3/8-16 x 2-1/4 Hex Bolt	2
11	8105-1	Rear Body Panel	1	F051		3/8 SAE Washer	4
12	8389-2	Splash Guard with Mat	1	F059		3/8 Wave Spring Washer	2
13	8389-12	Rubber Mat (3 x 3)	1	F128		10-24 x 3/8 PTHMS	4

NOTE: Refer to **BODY / CHASSIS ASSEMBLY (GHS MODELS) MT/MTEFI**, Page 4 for all common parts used on both models.

BODY ASSEMBLY (SD MODELS) MT/MTEFI

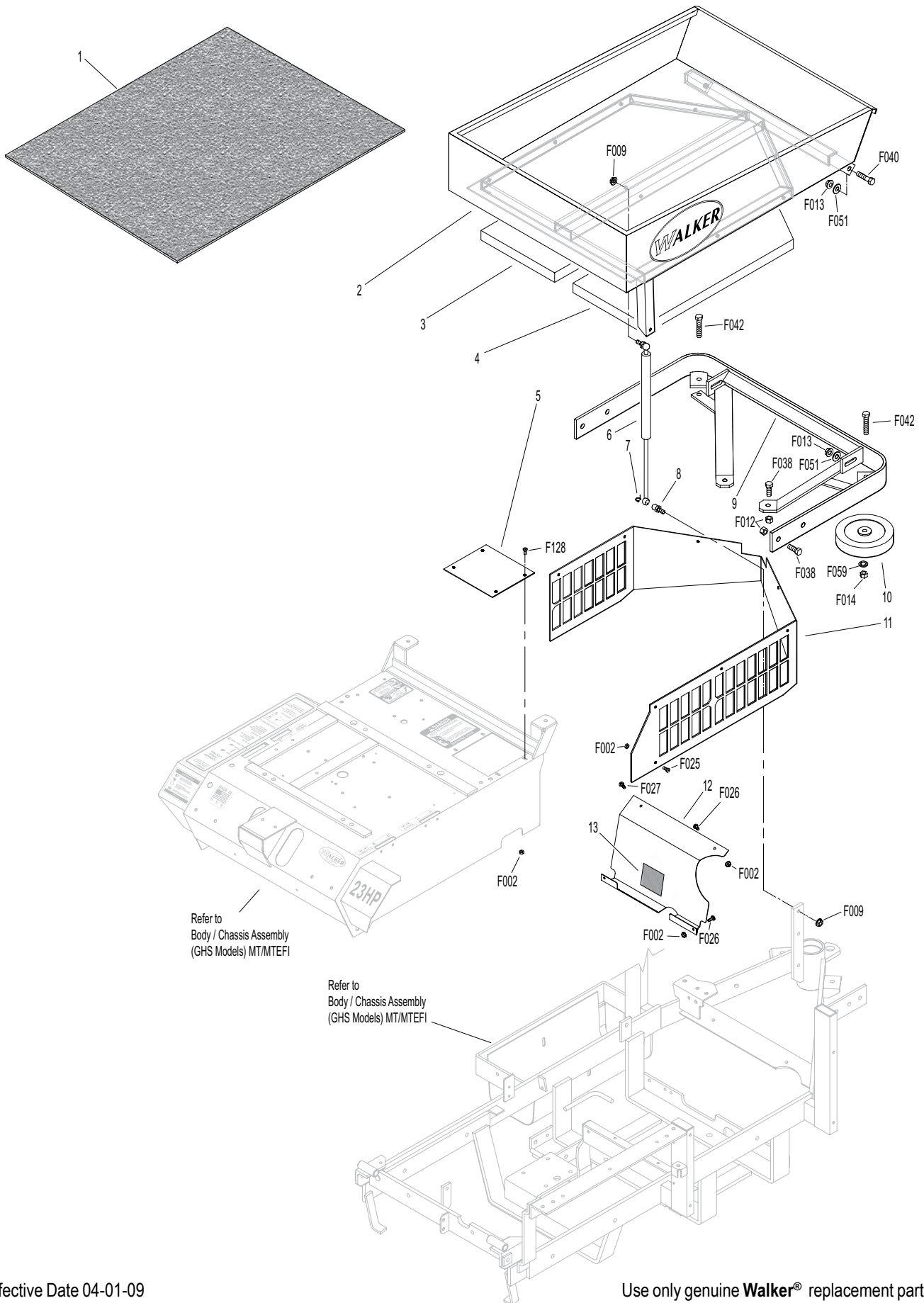

BODY ASSEMBLY (SD MODELS) MTL/MTLEFI

ITEM NO.	PART NO.	DESCRIPTION	NO. REQ'D	ITEM NO.	PART NO.	DESCRIPTION	NO. REQ'D
Utility Bed Assembly				Fasteners			
1	8650-10	Bed Liner (21.5 x 27.5)	1	F002		10-24 Keps Nut	13
2	8650-3	Utility Bed (Includes Item # 1)	1	F009		5/16-18 Whiz Locknut	2
3	7190-2	Insulation Foam Pad, RH	1	F012		3/8-16 Keps Nut	6
4	7190-1	Insulation Foam Pad, LH	1	F013		3/8-16 Whiz Locknut	4
Rear Bumper Assembly (SD Models)				F014		3/8-16 ESNA Nut	2
5	7153-3	Cover Plate	1	F025		10-24 x 3/8 PPHMS	5
6	7145	Gas Spring Assembly (Includes Items # 7 & 8)	1	F026		10-24 x 1/2 PPHMS	4
7	7147	Spring Clip	2	F027		10-24 x 5/8 PPHMS	1
8	7146	13mm Ball Stud	2	F038		3/8-16 x 1 Hex Bolt	6
9	7521-5	Rear Bumper	1	F040		3/8-16 x 1-1/2 Hex Bolt	2
10	5162	Roller Wheel (5" Rubber)	2	F042		3/8-16 x 2-1/4 Hex Bolt	2
11	8105-16	Rear Body Panel	1	F051		3/8 SAE Washer	4
12	8389-3	Splash Guard	1	F059		3/8 Wave Spring Washer	2
				F128		10-24 x 3/8 PTHMS	4

NOTE: Refer to **BODY / CHASSIS ASSEMBLY (GHS MODELS) MTL/MTLEFI**, Page 6 for all common parts used on both models.

BODY ASSEMBLY (SD MODELS) MTL/MTLEFI

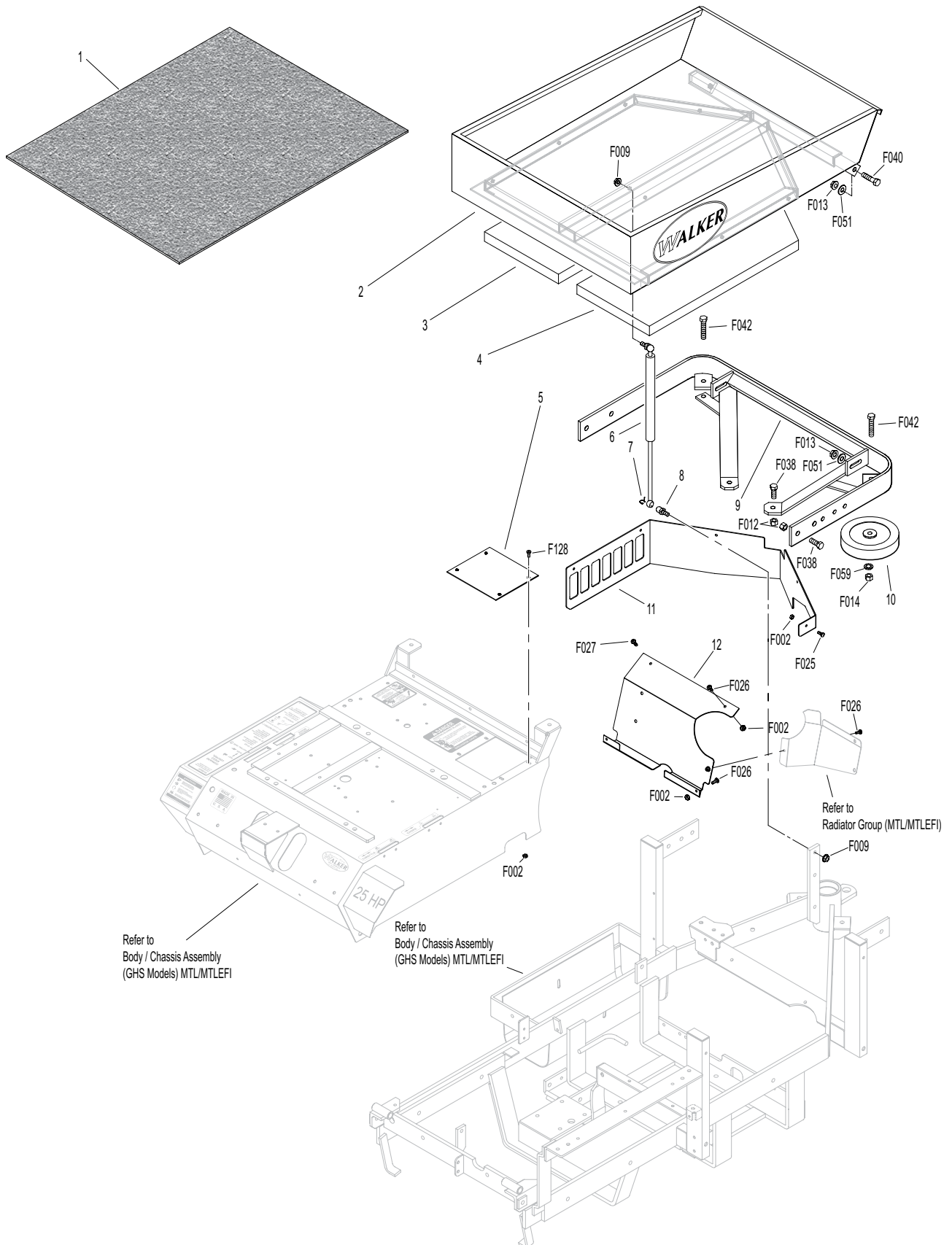

MAIN COMPONENT POWER TRANSMISSION (GHS MODELS)

ITEM NO.	PART NO.	DESCRIPTION	NO. REQ'D	ITEM NO.	PART NO.	DESCRIPTION	NO. REQ'D
Clutch Lever Assembly				44	5221-1	Extension Spring (3/4 x 5)	2
1	8358-3	Clutch Lever (Includes Items # 2 & 3)	1	45	8539	Starter Relay Mount	1
2	5830	Grease Fitting	7	46	5268	Bearing W/Collar (3/4)	2
3	7860	Handle Grip	1	47	7241-2	Transmission Drive Pulley (3-1/4MV) (Includes Items # F067 & F171)	1
4	7303-10	Clutch Actuator Bolt (3/8)	1	48	7833	Cable Clamp (7/8 x 1/4)	1
5	7380-5	Knuckle Joint (3/8 ID)	1	49	8349	Transmission Belt Tightener Arm	1
6	7226-10	Compression Spring (3/4 x 2-1/2)	1	50	8394-1	Hydro Jackshaft Mount Assembly (Includes Items # 2, 9, 43, 46, 50 & 51)	*
7	8130-5	Pushrod, Clutch Actuator (Threaded Tube)	1	51	8273	Jackshaft (3/4 x 7-1/2)	1
8	8130-10	Clutch Actuator Rod Assembly (Includes Items # 2, 4-7, F054, F336 & F353)	1	52	7240-3	Jackshaft Drive Pulley (4.15/3V) (Includes Items # F067 & F171)	1
9	7201-3	DU Bearing	6	53	7240-4	Jackshaft Drive Pulley (3.3/3V) (Includes Items # F067 & F171)	1**
10	7201-5	Inner Race (2-1/4)	1	54	8349-3	Idler Arm, MTLEFI	1***
11	8368	PTO Belt Tightener	1	55	6325-4	Spacer Bushing (3/16)	1***
12	5841	Retainer Washer (3/8 x 1-1/4)	4	Fasteners			
13	8243	Clutch Idler Pulley Assembly (Includes Items # 14, 15 & F070)	1	F003	1/4-28 Hex Nut	2	
	8243-1	Clutch Idler Pulley	1	F004	1/4-20 Keps Nut	3	
14	5265	Bearing (3/4)	1	F005	1/4-20 ESNA Nut	1	
15	8243-3	Hub, Idler Pulley	1	F009	5/16-18 Whiz Locknut	3	
16	8375	PTO Belt Tightener Stop	1	F012	3/8-16 Keps Nut	7	
17	7377	Plastic Washer (1 x .438 x .025)	2	F029	1/4-20 x 1/2 Hex Bolt	1	
18	7378	Pivot Bearing (7/16 x 9/16)	1	F040	3/8-16 x 1-1/2 Hex Bolt	1	
19	5281-1	Clevis Spring Pin	1	F041	3/8-16 x 1-3/4 Hex Bolt	2	
20	5280	Clevis (1/4)	2	F042	3/8-16 x 2-1/4 Hex Bolt	3	
21	8305	Brake Actuator Rod	1	F043	3/8-16 x 3 Hex Bolt	1	
22	8370	Bearing, Brake Actuator	1	F047	3/8-16 x 4-1/2 Hex Bolt	1	
23	5281-5	Clevis Pin (1/4 x 0.80)	1	F054	AN960616 Washer	3	
24	8250	Brake Spring (1/2 x 2-1/2)	1	F061	1/4 Internal Star Lock Washer	1	
25	8369	Brake Actuator (Includes Items # 2 & 22)	1	F067	3/16 x 3/16 x 1 Key	2	
PTO Drive Shaft Assembly				F069	3/32 x 1/2 Cotter Pin	1	
26	7050-1	Dipstick, Gearbox	1	F070	1-3/4 Internal Snap Ring	1	
27	8371-1	Mount Bracket, Brake Band	1	F090	1/4-20 x 2-1/2 Hex Bolt	1	
28	8377	Brake Band Guide	1	F116	1/4-20 x 1-1/4 Hex Bolt	1	
29	8050-11	PTO Gearbox / Flange Pulley	1	F121	5/16-18 x 3/8 x 1 SHL Bolt	1	
30	5245	Idler Pulley (3")	2	F131	5/16-18 x 1/2 Hex Bolt	2	
31	7248	Ground Drive Belt, Micro-V	1	F132	1/4-20 x 2-3/4 Hex Bolt	1	
32	7275-16	Universal Joint Tube Assembly/Spline	1	F168	5/16 Split Lock Washer	14	
33	7275-9	Quick Coupler Installation Tool	1	F171	5/16-18 x 3/8 Set Screw	4	
34	7523-2	Clevis Pin w/Hole (1/4 x 5/8)	1	F178	1/4 x 1 Fender Washer	1	
35	8304	Brake Band (14-1/2)	1	F182	1/4 x 5/8 x 1/8 Washer	2	
36	6250	Drive Belt (3VX375) MT / MTEFI	1	F186	5/64 x 1/2 Cotter Pin	1	
	6250-1	Drive Belt (3VX370) MTL / MTLEFI	1**	F226	5/16-18 x 7/8 Hex Bolt	14	
37	7236-1	PTO Drive Pulley (4-1/2/3V) (Includes Items # F168 & F226)	1	F241	.375 x .875 x .10 Washer	1	
38	8237-2	Engine Pulley, Bolt On (4/3.8/3V) (Includes Items # F168 & F226)	1	F255	5/16-18 x 1-1/2 Hex Bolt	2	
39	8230	Engine PTO Belt	1	F261	AN960616L Washer	1	
Jackshaft Assembly				F336	3/8-16 Jam Nut	1	
40	7245-1	Idler Pulley (3/8 Groove)	1	F353	3/8-16 ESNA LP Nut	1	
41	6325-2	Spacer Bushing (5/16)	2	* Service Part Only			
42	8349-2	Idler Arm	1	** Item used on MTL and MTLEFI only			
43	7201-4	Inner Race (1-1/2)	2	*** Item used on MTLEFI only			

Use only genuine **Walker**® replacement parts.

Effective Date 04-01-09

MAIN COMPONENT POWER TRANSMISSION (GHS MODELS)

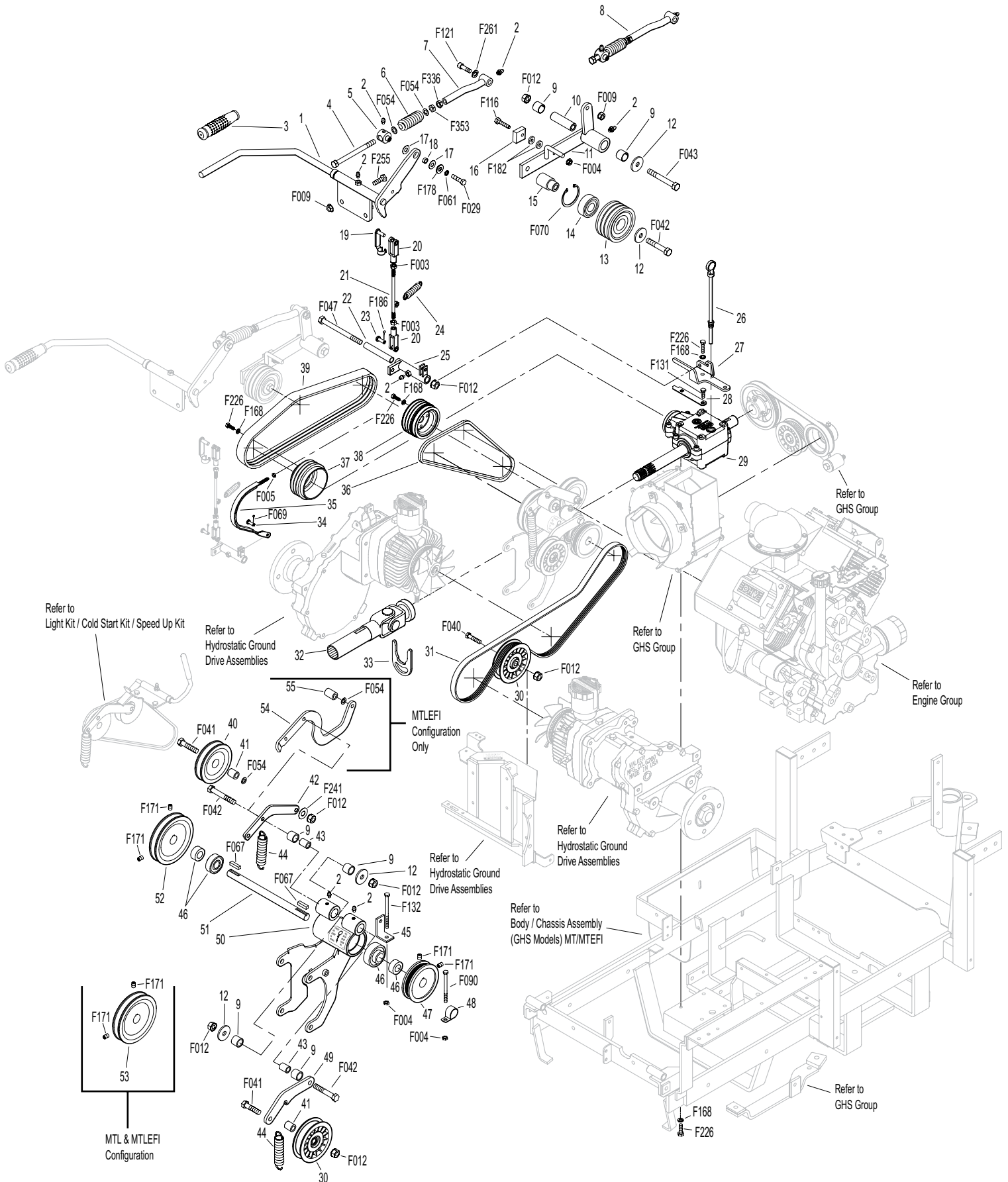

Effective Date 04-01-09

Use only genuine **Walker®** replacement parts.

MAIN COMPONENT POWER TRANSMISSION (SD MODELS)

ITEM NO.	PART NO.	DESCRIPTION	NO. REQ'D	ITEM NO.	PART NO.	DESCRIPTION	NO. REQ'D
Clutch Lever Assembly				45	8539	Starter Relay Mount	1
1	8358-3	Clutch Lever (Includes Items # 2 & 3)	1	46	5268	Bearing W/Collar (3/4)	2
2	5830	Grease Fitting	7	47	7241-2	Transmission Drive Pulley (3-1/4MV) (Includes Items # F067 & F171)	1
3	7860	Handle Grip	1	48	7833	Cable Clamp (7/8 x 1/4)	1
4	7303-10	Clutch Actuator Bolt (3/8)	1	49	7394-6	Idler Pulley Spring Mount	1 ^Δ
5	7380-5	Knuckle Joint (3/8 ID)	1	50	8349	Transmission Belt Tightener Arm	1
6	7226-10	Compression Spring (3/4 x 2-1/2)	1	51	8393-7	Hydro Jackshaft Mount	1
7	8130-5	Pushrod, Clutch Actuator (Threaded Tube)	1		8394-1	Hydro Jackshaft Mount Assembly (Includes Items # 2, 9, 43, 46, 51 & 52)	*
8	8130-10	Clutch Actuator Rod Assembly (Includes Items # 2, 4-7, F054, F336 & F353)	1	52	8273	Jackshaft (3/4 x 7-1/2)	1
9	7201-3	DU Bearing	6	53	7240-3	Jackshaft Drive Pulley (Includes Items # F067 & F171)	1
10	7201-5	Inner Race (2-1/4)	1	54	7240-4	Jackshaft Drive Pulley (3.3/3V) (Includes Items # F067 & F171)	1**
11	8368	PTO Belt Tightener	1	55	8349-3	Idler Arm, MTLEFI	1***
12	5841	Retainer Washer (3/8 x 1-1/4)	4	56	6325-4	Spacer Bushing (3/16)	1***
13	8243	Clutch Idler Pulley Assembly (Includes Items # 14, 15 & F070)	1	Fasteners			
	8243-1	Clutch Idler Pulley	1	F003	1/4-28 Hex Nut		2
14	5265	Bearing (3/4)	1	F004	1/4-20 Keps Nut		3
15	8243-3	Hub, Idler Pulley	1	F005	1/4-20 ESNA Nut		1
16	8375	PTO Belt Tightener Stop	1	F009	5/16-18 Whiz Locknut		3
17	7377	Plastic Washer (1 x .438 x .025)	2	F012	3/8-16 Keps Nut		7
18	7378	Pivot Bearing (7/16 x 9/16)	1	F029	1/4-20 x 1/2 Hex Bolt		1
19	5281-1	Clevis Spring Pin	1	F040	3/8-16 x 1-1/2 Hex Bolt		1
20	5280	Clevis (1/4)	2	F041	3/8-16 x 1-3/4 Hex Bolt		2
21	8305	Brake Actuator Rod	1	F042	3/8-16 x 2-1/4 Hex Bolt		3
22	8370	Bearing, Brake Actuator	1	F043	3/8-16 x 3 Hex Bolt		1
23	5281-5	Clevis Pin (1/4 x 0.80)	1	F047	3/8-16 x 4-1/2 Hex Bolt		1
24	8250	Brake Spring (1/2 x 2-1/2)	1	F054	AN960616 Washer		3
25	8369	Brake Actuator (Includes Items # 2 & 22)	1	F061	1/4 Internal Star Lock Washer		1
PTO Drive Shaft Assembly				F067	3/16 x 3/16 x 1 Key		2
26	7050-1	Dipstick, Gearbox	1	F069	3/32 x 1/2 Cotter Pin		1
27	8371-1	Mount Bracket, Brake Band	1	F070	1-3/4 Internal Snap Ring		1
28	8377	Brake Band Guide	1	F090	1/4-20 x 2-1/2 Hex Bolt		2
29	8050-11	PTO Gearbox / Flange Pulley	1	F116	1/4-20 x 1-1/4 Hex Bolt		1
30	5245	Idler Pulley (3")	2	F121	5/16-18 x 3/8 x 1 SHL Bolt		1
31	7248	Ground Drive Belt, Micro-V	1	F131	5/16-18 x 1/2 Hex Bolt		2
32	7275-16	Universal Joint Tube Assembly/Spine	1	F168	5/16 Split Lock Washer		14
33	7275-9	Quick Coupler Installation Tool	1	F171	5/16-18 x 3/8 Set Screw		4
34	7523-2	Clevis Pin w/Hole (1/4 x 5/8)	1	F178	1/4 x 1 Fender Washer		1
35	8304	Brake Band (14-1/2)	1	F182	1/4 x 5/8 x 1/8 Washer		2
36	6250	Drive Belt (3VX375) MT / MTEFI	1	F186	5/64 x 1/2 Cotter Pin		1
	6250-1	Drive Belt (3VX370) MTL / MTLEFI	1**	F226	5/16-18 x 7/8 Hex Bolt		14
37	7236-1	PTO Drive Pulley (4-1/2/3V) (Includes Items # F168 & F226)	1	F241	.375 x .875 x .10 Washer		1
38	8237-2	Engine Pulley, Bolt On (4/3.8/3V) (Includes Items # F168 & F226)	1	F255	5/16-18 x 1-1/2 Hex Bolt		2
39	8230	Engine PTO Belt	1	F261	AN960616L Washer		1
Jackshaft Assembly				F336	3/8-16 Jam Nut		1
40	7245-1	Idler Pulley (3/8 Groove)	1	F353	3/8-16 ESNA LP Nut		1
41	6325-2	Spacer Bushing (5/16)	2	* Service Part Only			
42	8349-2	Idler Arm	1	** Item used on MTL and MTLEFI only			
43	7201-4	Inner Race (1-1/2)	2	*** Item used on MTLEFI only			
44	5221-1	Extension Spring (3/4 x 5)	2	Δ Item used on MT only			

Use only genuine **Walker**® replacement parts.

Effective Date 04-01-09

MAIN COMPONENT POWER TRANSMISSION (SD MODELS)

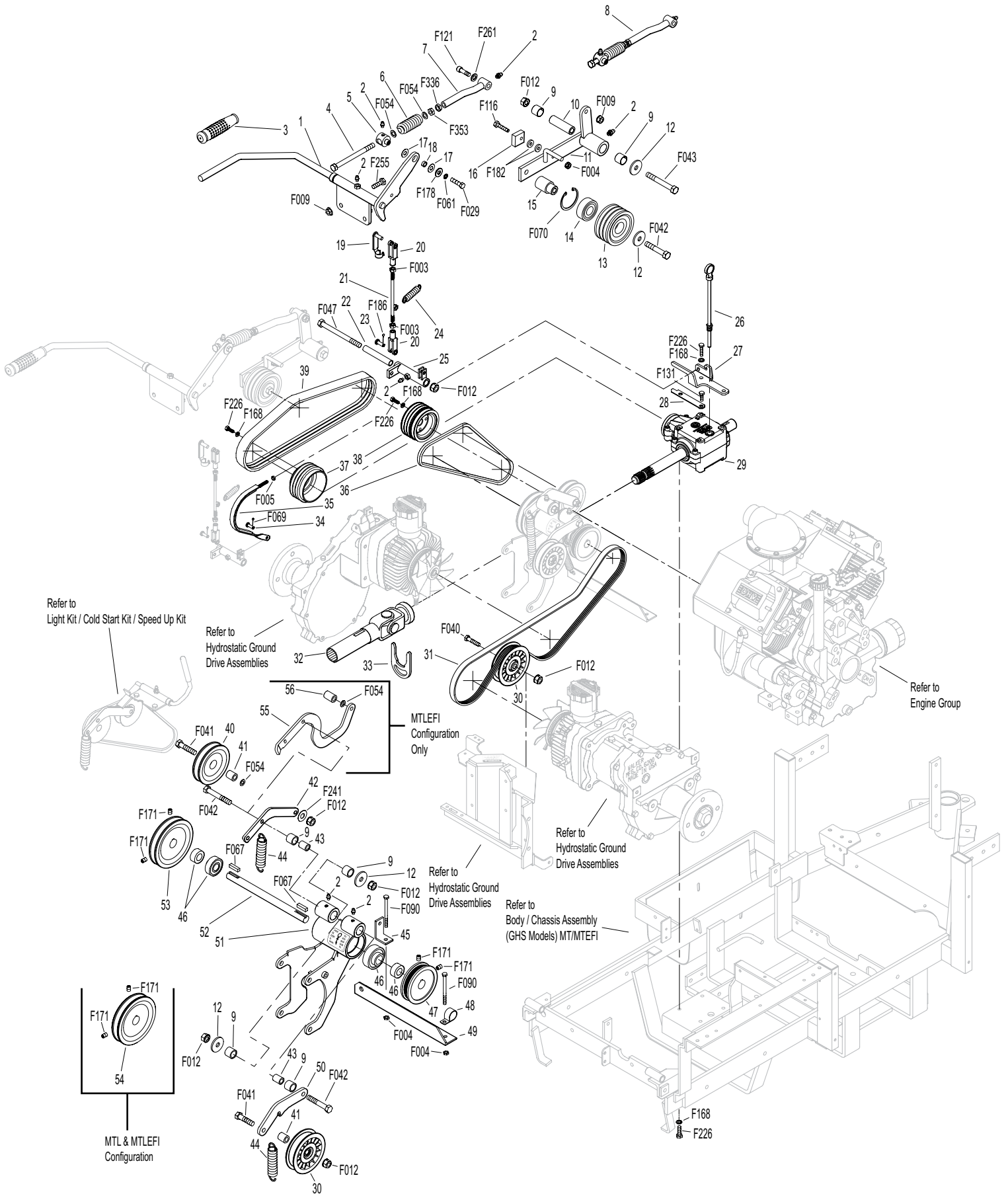

Effective Date 04-01-09

Use only genuine **Walker®** replacement parts.

ENGINE GROUP (MT)

ITEM NO.	PART NO.	DESCRIPTION	NO. REQ'D	ITEM NO.	PART NO.	DESCRIPTION	NO. REQ'D
Precleaner Assembly				Exhaust Assembly			
1	7026-2	Remote Precleaner (Includes Item # 5)	1	40	8530-8	Muffler Grass Shield (Includes Items # F002 & F025)	1
2	7440	Shock Mount (1.0 OD x .75)	3	41	NS	Screw (Kohler M-645016-S)	2
3	7028-20	Rear Precleaner Mount	1	42	NS	Gasket (Kohler)	2
4	7027	Elbow, Precleaner	1	43	NS	Nut (Kohler)	4
5	7840	Hose Clamp (1-5/16 to 2-1/4)	4	44	8013-9	Muffler	1
6	5088-12	Air Cleaner Assembly (Includes Items # 8-12 & 14)	*	45	8013-2	Upright Support	1
7	5088-1	Air Cleaner Band	1	46	8013-13	Muffler Heat Shield	1
8	5090-3	Safety Filter Insert	1	47	8013-61	Muffler Heat Deflector W/Knurled Inserts	1
9	5090-1	Air Cleaner Cartridge	1	48	8013-29	Muffler Heat Shield Endcap	1
10	5088-5	Air Cleaner Draw Latch	2	49	8013-18	Muffler Brace	1
11	5088-11	Air Cleaner Cap (Includes Item # 10)	1	50	8021	Engine Brace	1
12	5090-2	Vacuator Valve	1	Fasteners			
13	8026-10	Air Hose, Cleaner	1	F002	10-24 Keps Nut		2
14	5091-11	Air Flow Indicator & Nipple	1	F004	1/4-20 Keps Nut		6
15	7031	Tube Support Arm	1	F009	5/16-18 Whiz Locknut		10
16	7028-3	Precleaner Tube, SD	1	F012	3/8-16 Keps Nut		3
17	7028-2	Precleaner Tube, GHS	1	F025	10-24 x 3/8 PPHMS		2
18	6029	Hose Clamp (2-1/2)	1	F026	10-24 x 1/2 PPHMS		3
Engine Assembly				F029	1/4-20 x 1/2 Hex Bolt		4
19	NS	Fuel Pump (Kohler)	1	F031	1/4-20 x 5/8 Hex Bolt		3
20	5879-3	Hose Clamp (1/2)	4	F038	3/8-16 x 1 Hex Bolt		3
21	NS	Fuel Line, Engine (Kohler)	*	F050	1/4 SAE Washer		4
22	5020	Fuel Filter	*	F052	5/16 External Star Lock Washer		2
23	NS	Rectifier	*	F053	7/16 Int. Star Lock Washer		2
24	8016-4	Regulator Mount	1	F061	1/4 Internal Star Lock Washer		4
25	NS	Oil Filter (Kohler 1205001)	1	F063	3/8 Internal Star Lock Washer		2
26	NS	23-hp Engine	1	F079	A/A66D Aluminum Pop Rivet		2
27	8010-6	Valve Cover Sleeve	2	F090	1/4-20 x 2-1/2 Hex Bolt		1
28	5845	Bumper, Rubber (1.50 OD x 1.25)	1	F091	5/16-18 x 5/8 Hex Bolt		2
29	8010-2	Engine Bumper Mount	1	F106	3/8-16 x 5/8 Hex Bolt		2
30	5832	Cable Clamp (1/2)	3	F120	AN960416 Washer		2
Fuel Tank Assembly				F129	10-24 x 1/2 PTHMS		1
31	8015-3	Fuel Line, Tank (1/4 x 24-1/2)	1	F132	1/4-20 x 2-3/4 Hex Bolt		1
32	5083-1	Bushing, Rubber	*	F140	7/16-14 x 1 Hex Bolt		2
33	5086-7	Hose (3/8 x 6)	1	F175	1/2 Split Lock Washer		4
34	8023	Fuel Tank Support	1	F255	5/16-18 x 1-1/2 Hex Bolt		2
35	5020-2	Fuel Filter, In Tank	1	F256	7/16 SAE Washer		2
36	8046-9	Fuel Tank, 5 Gallon, Gas (Includes Items # 37 & 38)	1	F273	M6 x 1.0 Nut		4
37	5082-2	Fuel Cap Seal	*	F274	M6 x 1.0 x 45 Stud		2
38	5082	Fuel Tank Cap (Includes Item # 37)	*	F285	1/2-13 x 1-1/2 Hex Bolt		4
39	5083-5	Tank Tube Elbow	1	F324	M8 x 1.25 x 12 Hex Bolt		2

* Service Part Only

NOTE: Item 16 is used only on SD Models. Item 17 is used only on GHS Models. Both items use existing fasteners at clutch lever.

NOTE: Refer to Kohler Engine Decal (NS) for Engine Identification Number.

ENGINE GROUP (MT)

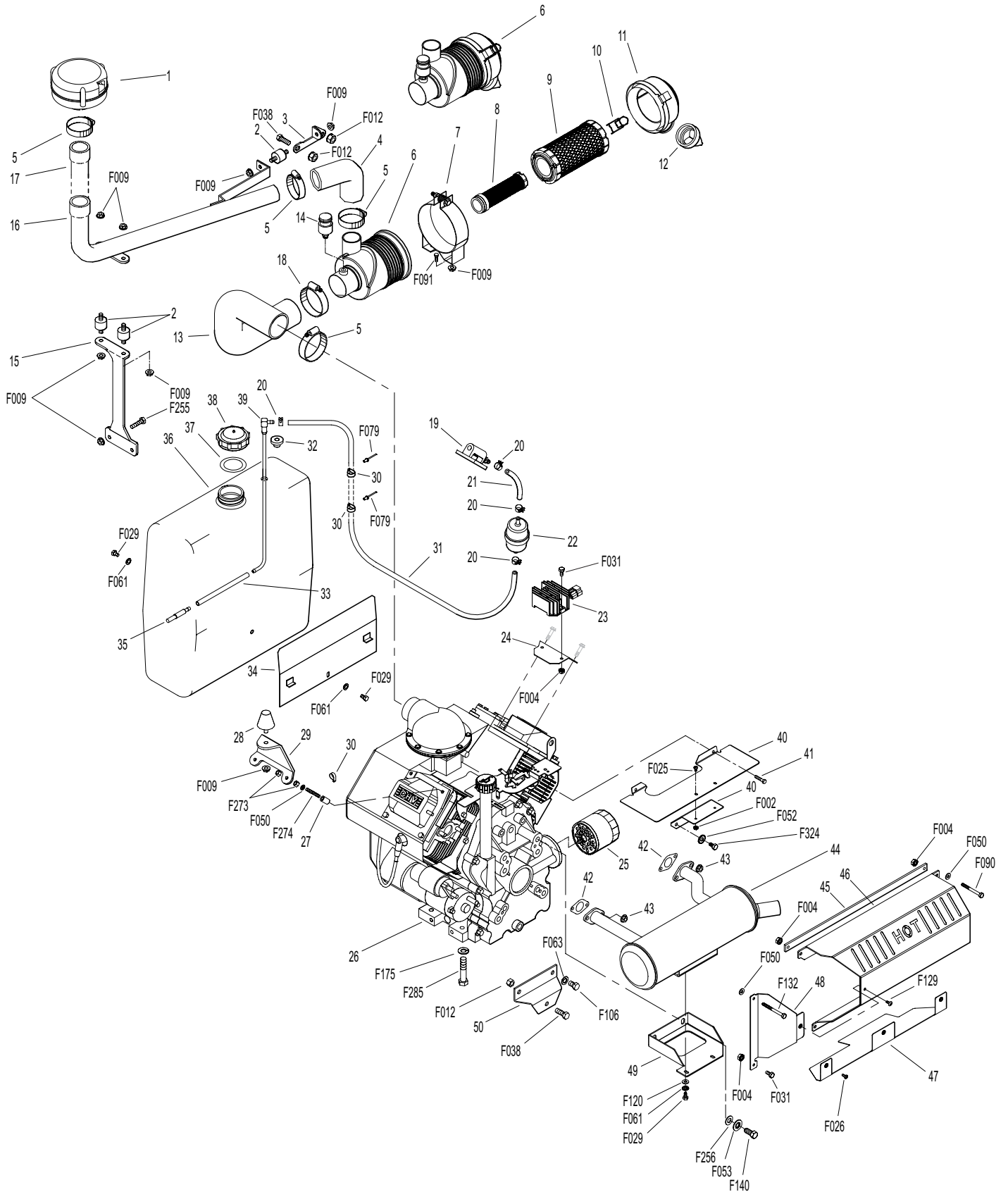

Effective Date 04-01-09

Use only genuine **Walker®** replacement parts.

ENGINE GROUP (MTL)

ITEM NO.	PART NO.	DESCRIPTION	NO. REQ'D	ITEM NO.	PART NO.	DESCRIPTION	NO. REQ'D
Fuel Tank Assembly				Engine Assembly			
1	5083-5	Tank Tube Elbow	1	25	NS	Regulator (Kohler)	1
2	5879-3	Hose Clamp (1/2)	4	26	NS	Oil Filter (Kohler 1205001)	1
3	8015-3	Hose (1/4 x 24-1/2)	1	27	NS	25-hp Engine	1
4	NS	Fuel Pump (Kohler)	1	28	7306-12	Temperature Sender Adapter	1
5	NS	Fuel Line (Kohler)	1	29	7306-15	Water Temperature Sender	1
6	5020	Fuel Filter	*	Fasteners			
7	5832	Cable Clamp (1/2) (Uses Existing Fasteners at Engine)	2				
8	5083-1	Bushing, Rubber	*	F002		10-24 Keps Nut	2
9	5086-7	Hose (3/8 x 6)	1	F004		1/4-20 Keps Nut	2
10	5020-2	Fuel Filter, In Tank	1	F009		5/16-18 Whiz Locknut	2
11	8046-9	Fuel Tank, 5 Gallon, Gas (Includes Items # 12 & 13)	1	F012		3/8-16 Keps Nut	6
12	5082-2	Fuel Cap Seal	*	F025		10-24 x 3/8 PPHMS	2
13	5082	Fuel Tank Cap (Includes Item # 12)	*	F029		1/4-20 x 1/2 Hex Bolt	2
Exhaust Assembly				F031		1/4-20 x 5/8 Hex Bolt	1
14	5665	Compression Spring (1/2 x 1)	2	F032		1/4-20 x 3/4 Hex Bolt	1
15	8530-15	Muffler End Shield	1	F041		3/8-16 x 1-3/4 Hex Bolt	4
16	8530-17	Upper Grass Shield	1	F050		1/4 SAE Washer	2
17	8013-34	Muffler Mount Tab	1	F051		3/8 SAE Washer	4
18	8013-37	Muffler	1	F052		5/16 Ext. Star Lock Washer	2
19	8531-10	Rear Muffler Heat Shield	1	F061		1/4 Internal Star Lock Washer	2
20	8013-16	Mounting Spring, Muffler	2	F063		3/8 Internal Star Lock Washer	1
21	8013-35	Exhaust Pipe, Muffler	1	F079		A/A66D Aluminum Pop Rivet	2
22	NS	Gasket (Kohler)	2	F091		5/16-18 x 5/8 Hex Bolt	2
23	NS	Nut (Kohler)	4	F151		3/8-16 x 7/8 Hex Bolt	2
24	8531-2	Grass Shield	1	F187		1/4-20 x 1-1/2 Hex Bolt	2
				F188		1/4-20 Self-Locking Nut	2
				F324		M8 x 1.25 x 12 Hex Bolt	2
				* Service Part Only			

NOTE: Refer to Kohler Engine Decal (NS) for Engine Identification Numbers.

ENGINE GROUP (MTL)

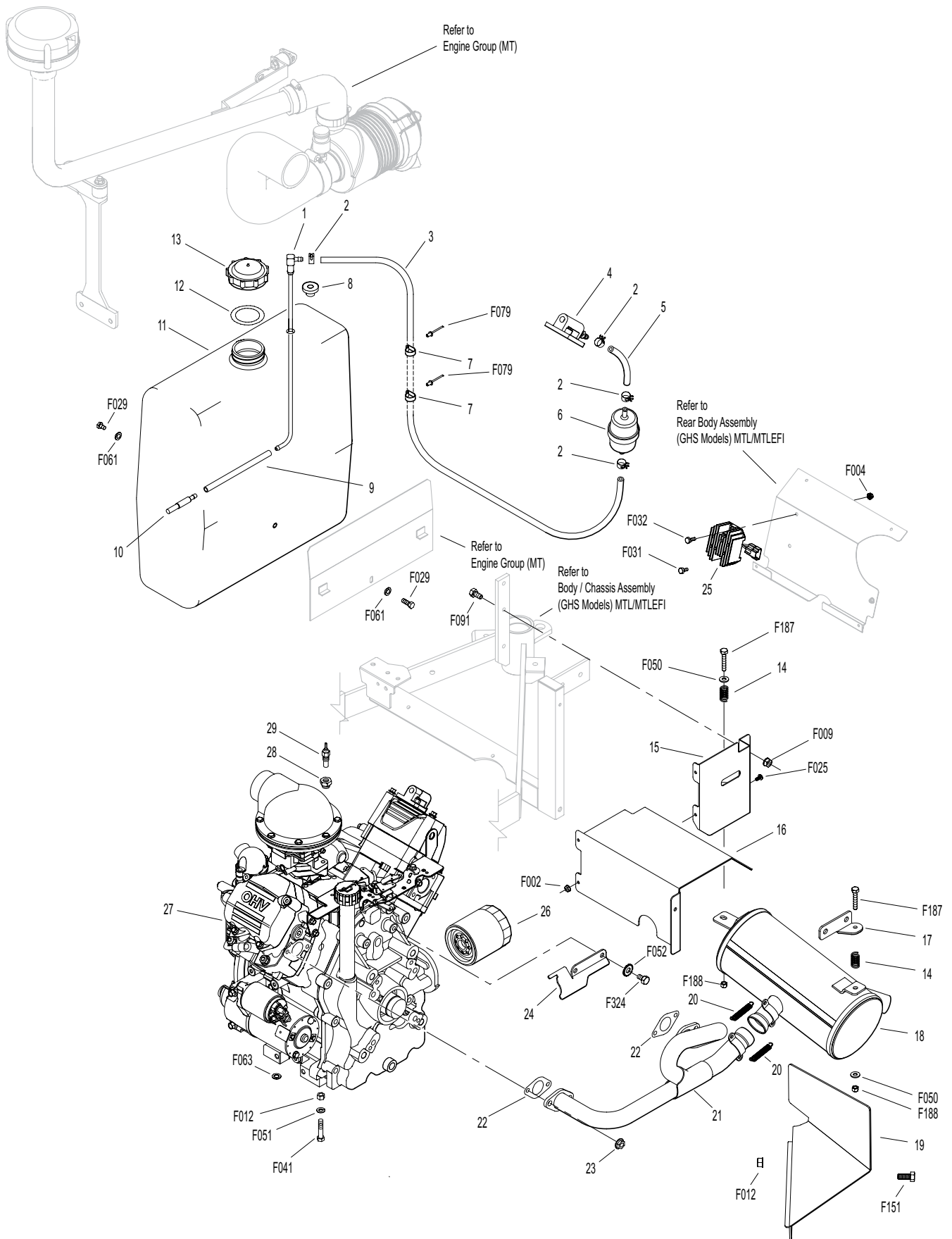

ENGINE GROUP (MTEFI)

ITEM NO.	PART NO.	DESCRIPTION	NO. REQ'D	ITEM NO.	PART NO.	DESCRIPTION	NO. REQ'D
Fuel Tank Assembly				Exhaust Assembly			
1	5083-2	Tank Tube Elbow	1	30	8530-9	Grass Shield, Muffler (EFI) (Includes Items # F002 & F025)	1
2	5879-5	Stepless Ear Clamp (5/8)	7	31	NS	Screw (Kohler M645016-S)	2
3	8026-3	Fuel Line (5/16 x 32) Tank to Pump (Includes Item # 2)	1	32	NS	Sensor, Oxygen (Kohler)	1
4	7833	Cable Clamp (7/8 x 1/4)	5	33	NS	Gasket (Kohler)	2
5	8026-5	HP Fuel Line (5/16 x 21) Regulator to Filter (Includes Item # 2)	1	34	NS	Nut (Kohler M-0841080)	4
6	8026-14	Clamp, Loop Style	1	35	8013-11	Muffler (EFI)	1
7	5879-3	Hose Clamp (1/2)	2	36	8013-2	Upright Support	1
8	NS	Fuel Regulator (Kohler)	1	37	8013-13	Muffler Heat Shield	1
9	NS	Fuel Filter (Kohler)	1	38	8013-61	Muffler Heat Deflector W/Knurled Inserts	1
10	8026-4	HP Fuel Line (5/16 x 8) Pump to Regulator (Includes Item # 2)	1	39	8013-29	Muffler Heat Shield Endcap	1
11	8026-6	HP Fuel Line (5/16 x 13") Filter to Engine (Includes Item # 2)	1	40	8013-18	Muffler Brace	1
12	NS	Fuel Pump (Kohler)	1	41	8021	Engine Brace	1
13	NS	Clamp (Kohler)	2	Fasteners			
14	7014-3	Fuel Pump Mount Plate	1	F002	10-24 Keps Nut		6
15	8026-8	Vent Tube, Regulator	1	F004	1/4-20 Keps Nut		10
16	7014-2	Regulator/Filter Mount	1	F012	3/8-16 Keps Nut		1
17	5832	Cable Clamp (1/2) (Uses Existing Fasteners at Engine)	3	F025	10-24 x 3/8 PPHMS		4
18	5083-1	Bushing, Rubber	*	F026	10-24 x 1/2 PPHMS		4
19	7046-1	Fuel Return Tube	1	F027	10-24 x 5/8 PPHMS		2
20	8026-7	Hose (1/4 x 16)	1	F029	1/4-20 x 1/2 Hex Bolt		6
21	5086	Hose (3/8 x 18)	1	F031	1/4-20 x 5/8 Hex Bolt		4
22	5020-2	Fuel Filter, In Tank	1	F038	3/8-16 x 1 Hex Bolt		1
23	5082	Fuel Tank Cap (Includes Item # 24)	*	F050	1/4 SAE Washer		1
24	5082-2	Fuel Cap Seal	*	F052	5/16 External Star Lock Washer		2
25	8046-7	Fuel Tank, 5 Gallon, Gas (Includes Items # 18, 23 & 24)	1	F053	7/16 Int. Star Lock Washer		2
Engine Assembly				F061	1/4 Internal Star Lock Washer		4
26	NS	Rectifier	*	F063	3/8 Internal Star Lock Washer		2
27	8016-4	Regulator Mount	1	F079	A/A66D Aluminum Pop Rivet		2
28	NS	Oil Filter (Kohler 1205001)	1	F090	1/4-20 x 2-1/2 Hex Bolt		1
29	NS	26-hp EFI Engine (78528)	1	F106	3/8-16 x 5/8 Hex Bolt		2
				F120	AN960416 Washer		2
				F129	10-24 x 1/2 PTHMS		1
				F132	1/4-20 x 2-3/4 Hex Bolt		1
				F140	7/16-14 x 1 Hex Bolt		2
				F175	1/2 Split Lock Washer		4
				F256	7/16 SAE Washer		2
				F285	1/2-13 x 1-1/2 Hex Bolt		4
				F324	M8 x 1.25 x 12 Hex Bolt		2

* Service Part Only

NOTE: Refer to Kohler Engine Decal (NS) for Engine Identification Numbers.

ENGINE GROUP (MTEFI)

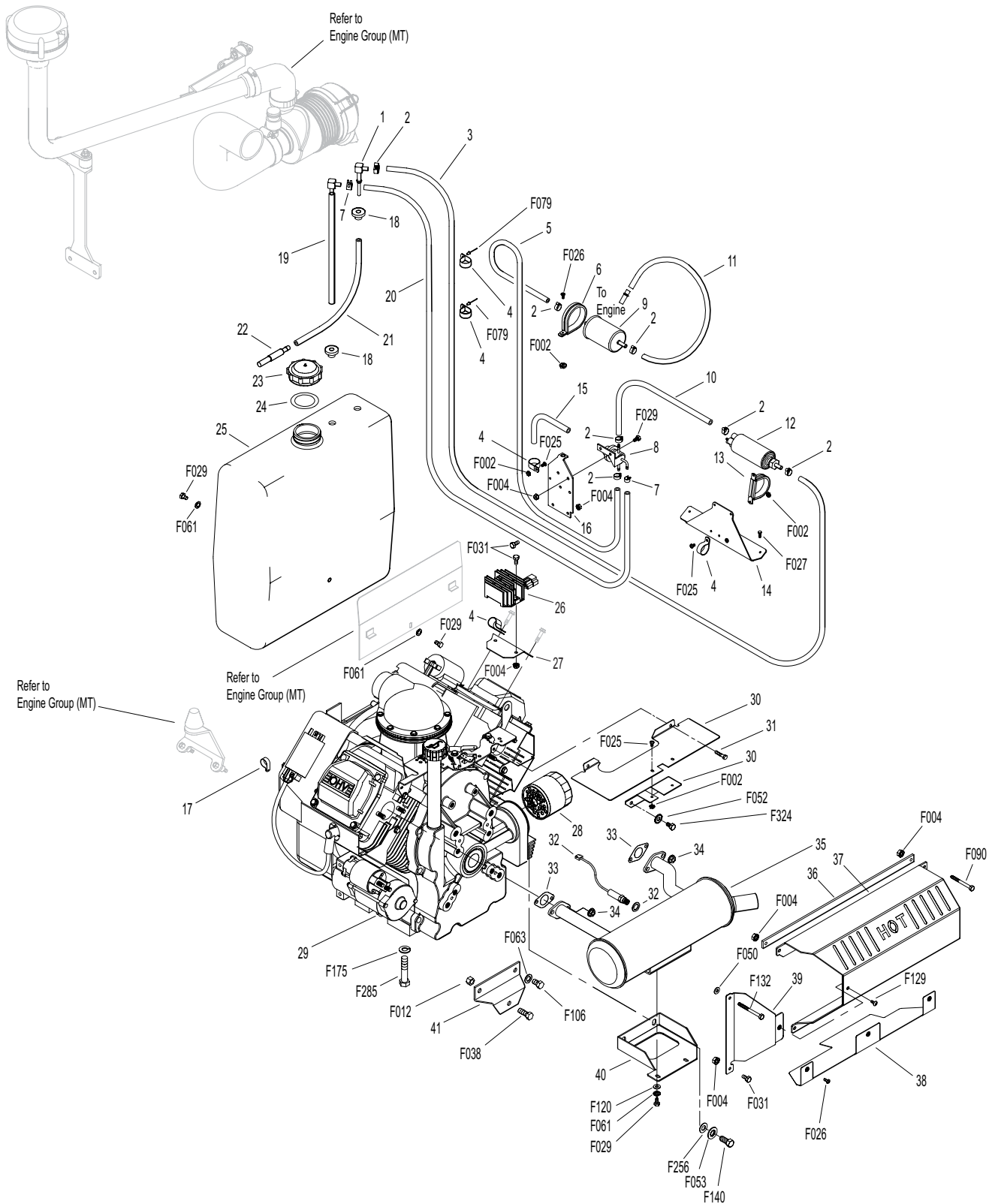

ENGINE GROUP (MTLEFI)

ITEM NO.	PART NO.	DESCRIPTION	NO. REQ'D	ITEM NO.	PART NO.	DESCRIPTION	NO. REQ'D
Fuel Tank Assembly				Engine Assembly			
1	8026-7	Hose (1/4 x 16)	1	41	NS	Regulator (Kohler)	1
2	8026-5	HP Fuel Line (5/16 x 21) Regulator To Filter (Includes Item # 3)	1	42	NS	Oil Filter (Kohler 1205001)	1
3	5879-5	Stepless Ear Clamp (5/8)	7	43	NS	25-hp Engine	1
4	8026-14	Clamp, Loop Style	1	44	7306-12	Temperature Sender Adapter	1
5	NS	Fuel Filter (Kohler)	1	45	7306-15	Water Temperature Sender	1
6	8026-12	HP Fuel Line (5/16 x 26) Filter to Engine	1	Fasteners			
7	7014-7	Fuel Line Guard	1		F002	10-24 Keps Nut	9
8	8026-11	HP Fuel Line (5/16 x 16) Pump To Regulator	1		F004	1/4-20 Keps Nut	6
9	8026-8	Vent Tube, Regulator	1		F009	5/16-18 Whiz Locknut	6
10	NS	Fuel Regulator (Kohler)	1		F012	3/8-16 Keps Nut	6
11	5879-3	Hose Clamp (1/2)	2		F025	10-24 x 3/8 PPHMS	4
12	7014-2	Regulator/Filter Mount	1		F026	10-24 x 1/2 PPHMS	7
13	7833	Cable Clamp (7/8 x 1/4)	1		F029	1/4-20 x 1/2 Hex Bolt	4
14	NS	Fuel Pump (Kohler)	1		F031	1/4-20 x 5/8 Hex Bolt	3
15	NS	Clamp (Kohler)	2		F032	1/4-20 x 3/4 Hex Bolt	1
16	5832	Cable Clamp (1/2)	1		F034	5/16-18 x 3/4 Hex Bolt	2
17	7014-5	Fuel Pump Mount (Includes Items # F002 & F004)	1		F041	3/8-16 x 1-3/4 Hex Bolt	4
18	7014-6	Fuel Pump Cover	1		F050	1/4 SAE Washer	2
19	8026-9	Hose (5/16 x 8) Tank to Pump	1		F051	3/8 SAE Washer	4
20	5083-2	Tank Tube Elbow	1		F052	5/16 Ext. Star Lock Washer	2
21	5083-4	Plug Bushing (Viton)	1		F061	1/4 Internal Star Lock Washer	2
22	5086-7	Hose (3/8 x 6)	1		F063	3/8 Internal Star Lock Washer	1
23	5020-2	Fuel Filter, In Tank	1		F091	5/16-18 x 5/8 Hex Bolt	2
24	8046-4	Fuel Tank, 5.0 Gallon, Gas, MTLEFI (Includes Items # 25, 26 & 27)	1		F151	3/8-16 x 7/8 Hex Bolt	2
25	5082-2	Fuel Cap Seal	1		F187	1/4-20 x 1-1/2 Hex Bolt	2
26	5082	Fuel Tank Cap (Includes Item # 25)	1		F188	1/4-20 Self-Locking Nut	2
27	5083-1	Bushing, Rubber	1		F255	5/16-18 x 1-1/2 Hex Bolt	2
28	7046-1	Fuel Return Tube	1		F324	M8 x 1.25 x 12 Hex Bolt	2
Exhaust Assembly				NOTE: Refer to Kohler Engine Decal (NS) for Engine Identification Numbers.			
29	5665	Compression Spring (1/2 x 1)	2				
30	8530-15	Muffler End Shield	1				
31	8530-17	Upper Grass Shield	1				
32	8013-34	Muffler Mount Tab	1				
33	8013-37	Muffler	1				
34	8013-16	Mounting Spring, Muffler	2				
35	8531-10	Rear Muffler Heat Shield	1				
36	8013-36	Exhaust Pipe	1				
37	NS	Nut (Kohler)	4				
38	NS	Gasket (Kohler)	2				
39	NS	Oxygen Sensor (Kohler)	1				
40	8531-2	Grass Shield	1				

Use only genuine **Walker**® replacement parts.

Effective Date 04-01-09

ENGINE GROUP (MTLEFI)

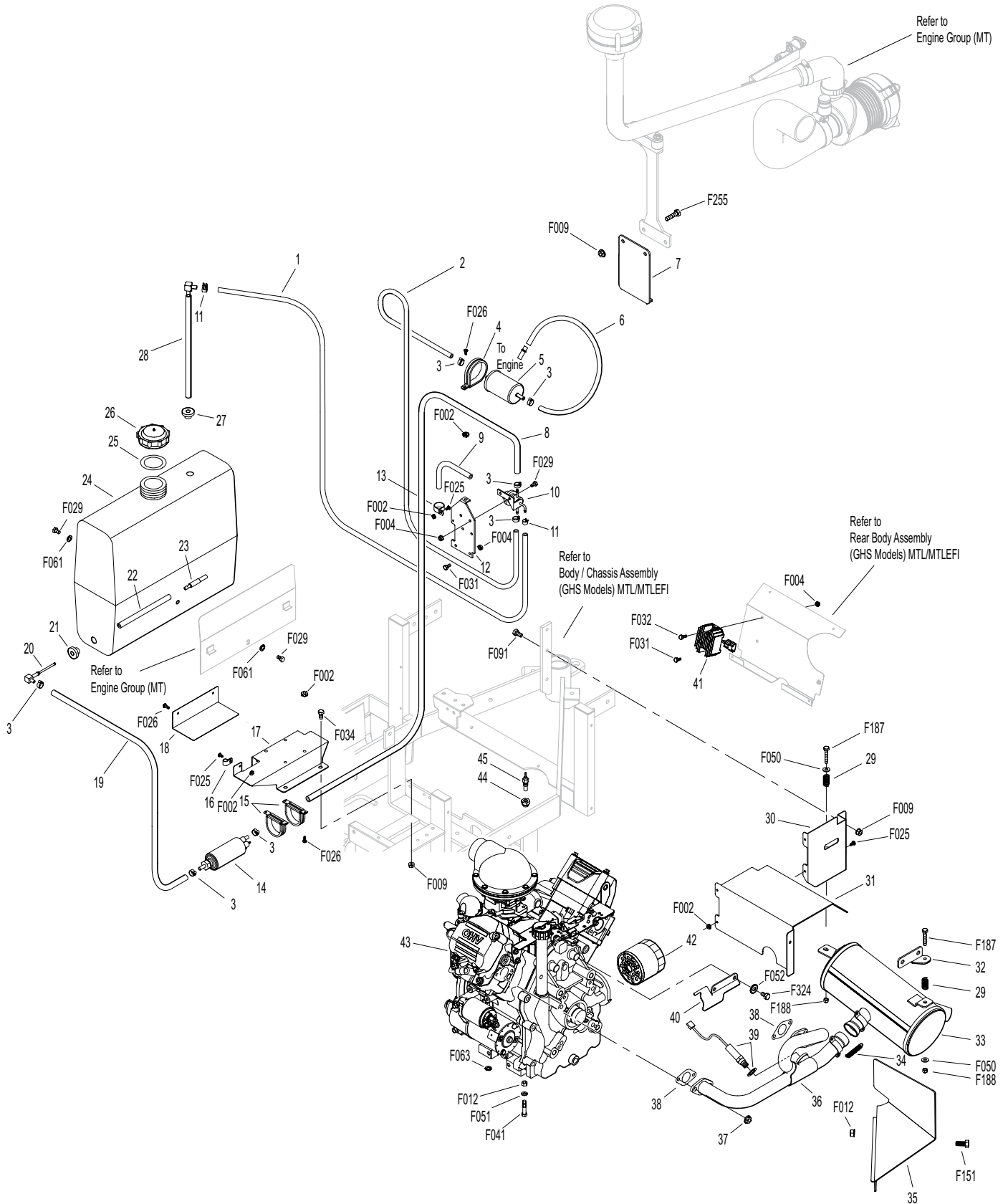

RADIATOR GROUP (MTL/MTLEFI)

ITEM NO.	PART NO.	DESCRIPTION	NO. REQ'D	ITEM NO.	PART NO.	DESCRIPTION	NO. REQ'D
Radiator Assembly				Fasteners			
1	8531-5	Top Shield	1	F002		10-24 Keps Nut	7
2	8531-8	Inner Shield	1	F004		1/4-20 Keps Nut	4
3	8531-9	Outer Shield	1	F014		3/8-16 ESNA Nut	2
4	7017-9	Upper Radiator Hose	1	F025		10-24 x 3/8 PPHMS	4
5	7840-3	Hose Clamp (1/2 to 1-1/4)	4	F026		10-24 x 1/2 PPHMS	3
6	8531-16	Dual Tee Coupling	1**	F029		1/4-20 x 1/2 Hex Bolt	4
7	7017-10	Upper Radiator Hose, Straight	1	F031		1/4-20 x 5/8 Hex Bolt	6
8	7833-2	Cable Clamp (1 x 1/4)	2	F032		1/4-20 x 3/4 Hex Bolt	6
9	7432	Shock Mount (1.00 OD x .75)	1	F053		7/16 Int. Star Lock Washer	2
10	7426-3	Rubber Isolator Mount	1	F061		1/4 Internal Star Lock Washer	14
11	7426-5	Screen Channel	2	F073		1/4 x 1.5 Fender Washer	2
12	7426-7	Radiator Brace	1	F129		10-24 x 1/2 PTHMS	11
13	7425	Radiator Screen	1	F132		1/4-20 x 2-3/4 Hex Bolt	2
14	7426-8	Screen Stop	2	F140		7/16-14 x 1 Hex Bolt	2
15	7431-2	Radiator Channel Seal	2	F360		1/4-20 x 3/8 Hex Bolt	1
16	7427-9	Radiator Cap	*				
17	7427-13	Radiator, MTL	1	*		Service Part Only	
18	7426-6	Radiator Fan Shroud, MTL	1	**		Item used on MTL only	
19	7427-22	Fan Mount Tab, RH	2	***		Item used on MTLEFI only	
20	7429-6	Radiator Cooling Fan	*				
21	7429-7	Fan Blade Replacement	*				
22	7427-21	Fan Mount Tab, LH	2				
23	8531-7	Rear Shield	1				
24	8531-6	Lower Shield	1				
25	7430-5	Radiator Guard	1				
26	7426-4	Radiator Mount	1				
27	7434	Rubber Washer (3/8 x 1-1/4 x 1/4)	4				
28	5841	Retainer Washer (3/8 x 1-1/4)	2				
29	7427-3	Coolant Recovery Tank	1				
30	7427-10	Recovery Tank Mount	1				
31	7427-11	Recovery Tank Keeper	1				
32	7015-13	Recovery Tank Hose (25")	1				
33	5975-3	Cable Tie (50# x 7")	3				
34	7017-6	Lower Radiator Hose	1				
35	7840-4	Hose Clamp (3/4 to 1-1/2)	2				
36	7017-7	Radiator Hose Bracket	1				
37	8531-13	Tee Coupling	1***				

NOTE: Decals for this assembly are not shown here. Refer to **TRACTOR DECALS**, Page 2 for Decal listing and placement information.

RADIATOR GROUP (MTL/MTLEFI)

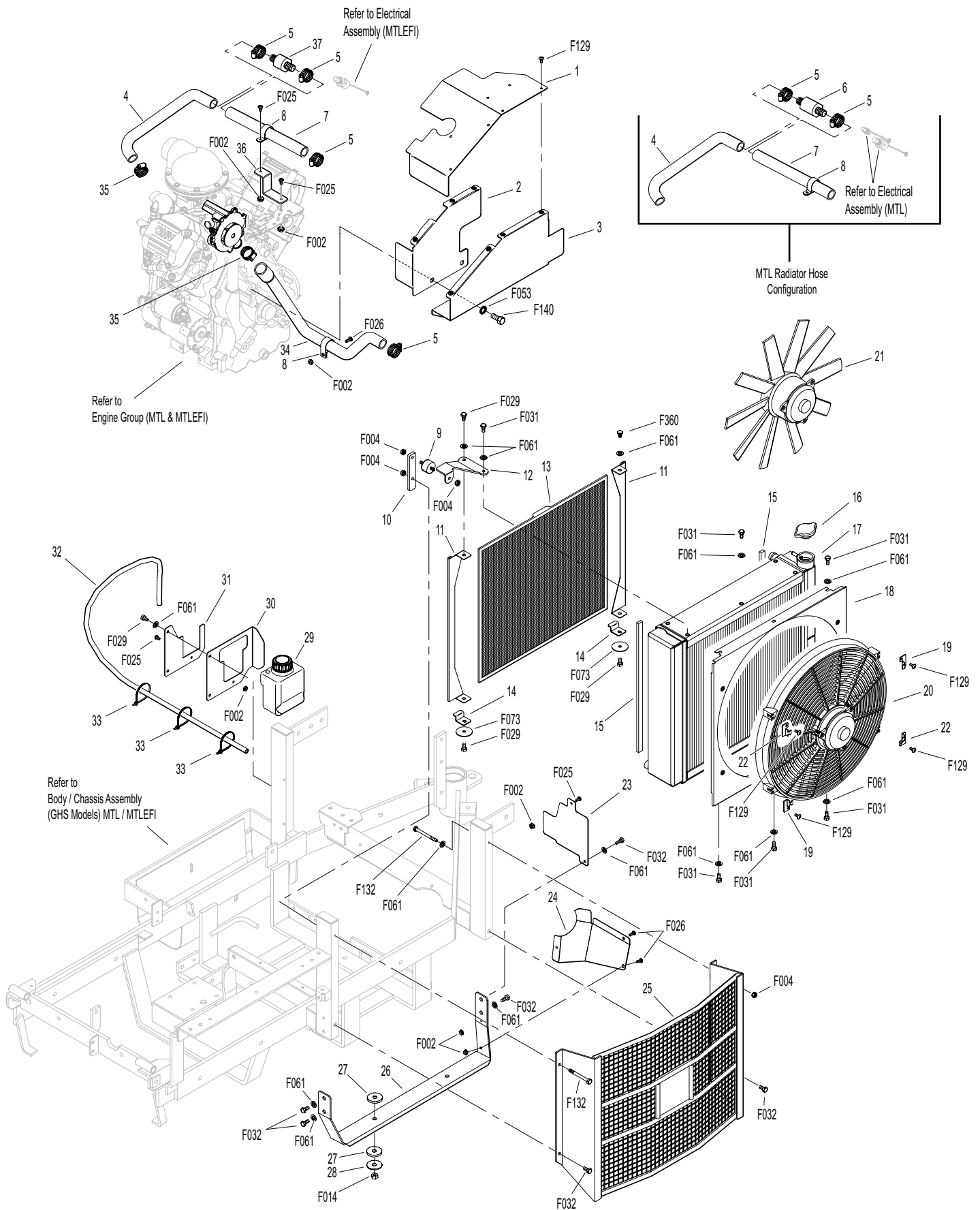

HYDROSTATIC GROUND DRIVE ASSEMBLIES

ITEM NO.	PART NO.	DESCRIPTION	NO. REQ'D	ITEM NO.	PART NO.	DESCRIPTION	NO. REQ'D
Transmission Lockout Assembly				Transmission Repair Parts			
1	5028-3	Transmission Lockout Assembly (Includes Items # 2-5, F023, F027 & F081)	*	26	5025-5	Input Shaft	*
2	5847	Plastic Tip	2	27	5025-8	Bearing, Input Shaft	*
3	5057	Lockout Cam (Includes Item # F081)	2	28	5025-7	Snap Ring	*
4	5028-5	Lockout Lever	2	29	5025-2	Seal, Input Shaft	*
5	5027-5	Lockout Mount	1**	30	5022	Reservoir to Casting Gasket	*
Ground Drive Assemblies				31	5024	Reservoir Cap and Gasket	*
6	6209-1	Bridge Assembly	1	32	5023	Transmission Reservoir Kit	*
	6209-2	Bridge Assembly, MTL	1***	33	5023-1	Rubber Bladder	*
7	6243-2	Hydro Fan, CCW	1	34	5025-6	O-Ring & Plug Assembly	*
8	5026	Hydrostatic Drive, CW (700-041)	1	35	5025-3	Seal, Control Shaft	*
9	6206-1	Air Vent Valve	*	Fasteners			
10	6200-9	Gear Axle Drive Assembly (Includes Items # 9 & 11)	2	F012	3/8-16 Keps Nut		2
11	6207-12	Pipe Plug (1/4 NPTF)	4	F023	10-24 ESNA Nut		2
12	5126	Cable Retainer (Uses existing bolt on Gear Axle Drive Assembly)	1	F027	10-24 x 5/8 PPHMS		2
13	6233-1	Pinion Gear	2	F036	1/4-20 x 1/2 SBH Screw		2
14	6234	Spacer, Pinion Gear	2	F038	3/8-16 x 1 Hex Bolt		4
15	6201	O-Ring Seal	2	F040	3/8-16 x 1-1/2 Hex Bolt		4
16	7244	Hydro Pulley (3-7/8/MV) (Includes Items # F064 & F359)	2	F043	3/8-16 x 3 Hex Bolt		6
17	6243-1	Hydro Fan, CW	1	F051	3/8 SAE Washer		2
18	5025	Hydrostatic Drive, CCW (700-042)	1	F053	7/16 Internal Star Lock Washer		4
Deck Support Arm Assemblies				F063	3/8 Internal Star Lock Washer		14
19	6430-10	Outboard Mount, LH	1	F064	1/8 x 1/2 Woodruff Key (#3)		4
20	6430-2	Deck Support Arm, LH (Includes Item # 24)	1	F081	A/A45D Aluminum Pop Rivet		2
21	5775-2	Hitch Pin (# 6)	2	F160	External Snap Ring (.669 Shaft)		2
22	6430-1	Deck Support Arm, RH (Includes Item # 24)	1	F178	1/4 x 1 Fender Washer		2
23	6430-9	Outboard Mount, RH	1	F194	7/16 x 1-1/4 x 1/8 Washer		2
24	5830	Grease Fitting	2	F200	7/16-20 x 3 Grade 8 Bolt		2
25	6840-1	Support Arm Bushing (2-1/16)	2	F244	7/16-20 x 3/4 Hex Bolt		2
				F262	3/8-16 x 4 Hex Bolt All Thread		1
				F359	5/16-18 x 5/16 Set Screw (Unbrako Knurl Point)		4
				F416	3/8-16 x 4 Socket Head Cap Screw		1
				* Service Part Only			
				** Part not used on Jackshaft side of tractor.			
				*** Item used on MTL and MTLEFI only			

Use only genuine **Walker**® replacement parts.

Effective Date 04-01-09

HYDROSTATIC GROUND DRIVE ASSEMBLIES

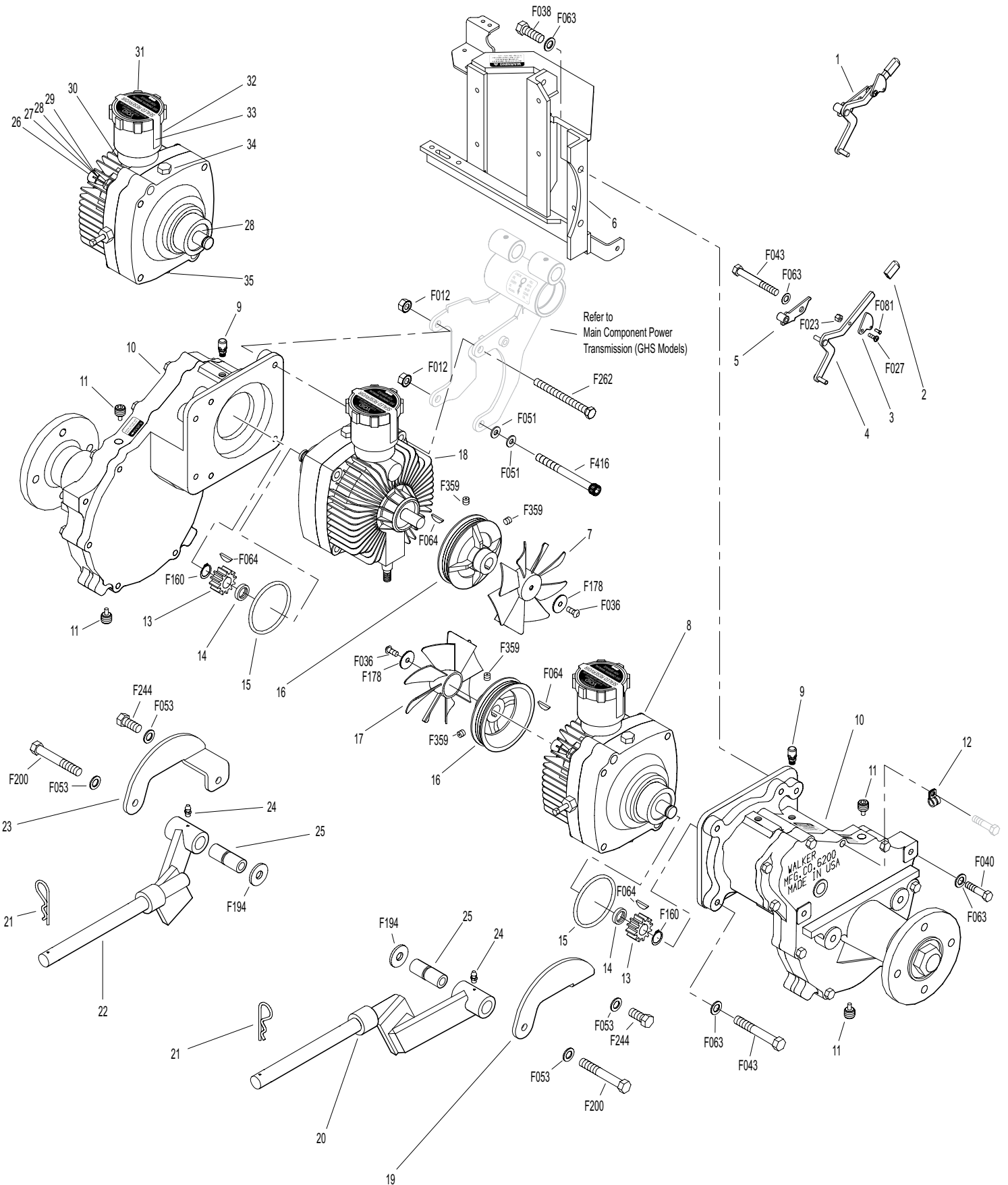

Effective Date 04-01-09

Use only genuine Walker® replacement parts.

STEERING CONTROL ASSEMBLIES

ITEM NO.	PART NO.	DESCRIPTION	NO. REQ'D	ITEM NO.	PART NO.	DESCRIPTION	NO. REQ'D
Transmission Spring Assemblies				35	5450-3	Steering Lever Assembly, RH / Adjustable (Includes Items # 16, 21, 36, F188, F198 & F345)	1
1	6199	Transmission Spring Assembly (RH) (Includes Items # 2-8, F003, F287, F320 & F352)	*		5450-5	Steering Lever Arm, RH / Adjustable	*
2	5552	Ball Joint (1/4-28)	2		5450-6	Steering Lever Assy RH / Adjustable / MTL	*
3	5192-1	Spring Plunger (Male)	2	36	5453-10	Steering Lever Handle, Adjustable (Includes Items # 21 & F345)	2
4	5194	Plunger Sleeve	2				
5	5193	Washer (3/4 x 1 x .085)	2	37	5862	FSC Knob	1
6	6191	Spring Slide (4-3/4)	1	38	7170	FSC Lever Assembly (Includes Item # 16)	1
7	5195-1	Compression Spring (1 x 6-1/4)	2				
8	6196	Spring Slide Cap	1	39	5975-3	Cable Tie (50# x 7")	1
9	5197	J-Bolt	1	40	5213-1	Control Rod, RH (15")	1
10	5191	Spring Slide (3-5/8)	1	41	6201-2	Shock Mount Gear Drive/RH	1**
11	5199	Transmission Spring Assembly (LH) (Includes Items # 2-5, 7, 9, 10, F003, F146, F287 & F352)	*	42	5146	10mm Ball Stud	4**
Steering Lever & FSC Assemblies				43	4215-2	Steering Lever Dampener	2**
12	5214-2	Ball Joint (5/16-24) Nylon Lined	2	44	5450-4	Steering Lever Arm RH / Adjustable / MTL	1**
13	5173	FSC Actuator Rod	1	45	5451-4	Steering Lever Arm LH / Adjustable / MTL	1**
14	5172	Bearing, Nylon (.255 ID x .379 OD x .250)	1	46	6201-1	Shock Mount Gear Drive/LH	1**
15	5142-2	FSC Actuator Cam	1	Fasteners			
16	5830	Grease Fitting	6	F003	1/4-28 Hex Nut		3
17	6212	Transmission Control Arm, RH	1	F004	1/4-20 Keps Nut		6
18	5141	FSC Friction Washer (1-1/2 x 3/8 x 1/16)	2	F007	5/16-18 Jam Nut		1
19	5140-15	FSC Friction Body (Includes Item # 16)	1	F008	5/16-24 Keps Nut		2
				F009	5/16-18 Whiz Locknut		5
20	5142-7	FSC Key W/Stop	1	F010	5/16-24 ESNA Nut		2
	5140-13	FSC Control Assembly (Includes Items # 15, 16, 18-20, F192 & F193)	*	F012	3/8-16 Keps Nut		2
21	5850-2	Handle Grip, Foam (5-1/2)	2	F024	5/16-24 Jam Nut		2
22	5212-2	Transmission Control Arm, LH	1	F029	1/4-20 x 1/2 Hex Bolt		2
23	5213-2	Control Rod, LH (6")	1	F032	1/4-20 x 3/4 Hex Bolt		4
24	5223	Extension Spring (1/4 x 5-1/2)	2	F034	5/16-18 x 3/4 Hex Bolt		1
25	5450	D-Clip	2	F050	1/4 SAE Washer		3
26	5463	Steering Lever Actuator	2	F051	3/8 SAE Washer		2
27	5214-1	Bearing (.320 x .438 x .250)	2	F064	1/8 x 1/2 Woodruff Key (#3)		2
28	5391-3	Steering Lever Support	1	F068	1/8 x 1 Cotter Pin		1
29	5217	Pivot Pin, Steering Lever	1	F069	3/32 x 1/2 Cotter Pin		1
30	5451-3	Steering Lever Assembly, LH / Adjustable (Includes Items # 16, 21, 36, F188, F198 & F345)	1	F093	5/16-18 x 1 Hex Bolt		1
	5451-5	Steering Lever Arm, LH / Adjustable	*	F146	1/4-20 Jam Nut		1
	5451-6	Steering Lever Assy, LH / Adjustable / MTL	*	F182	1/4 x 5/8 x 1/8 Washer		2
31	5219	Extension Spring (3/4 x 6-3/4)	1	F183	.312 x .700 x .074 Washer		2
32	5280	Clevis (1/4")	1	F186	5/64 x 1/2 Cotter Pin		1
33	5281-5	Clevis Pin (1/4 x 0.80)	1	F188	1/4-20 Self-Locking Nut		4
34	5470-1	Speed Control Stop	1	F192	3/8-24 Self-Locking Nut		1
				F193	3/8 Belleville Spring Washer		3
				F198	.250 x .625 x .040 Washer, SS		2
				F287	1/4-28 Keps Nut		2
				F320	1/8 x 3/4 Split Spring Pin		1
				F345	1/4-20 x .770 Knurled Bolt		4
				F350	1/4-20 LP Nylock		2
				F352	5/32 x 1 Heavy Duty Roll Pin		2
				F401	.504 x .751 x .030 Washer		1

* Service Part Only

** All parts for Steering Dampener MTL & MTLEFI only.

Use only genuine **Walker**® replacement parts.

Effective Date 04-01-09

STEERING CONTROL ASSEMBLIES

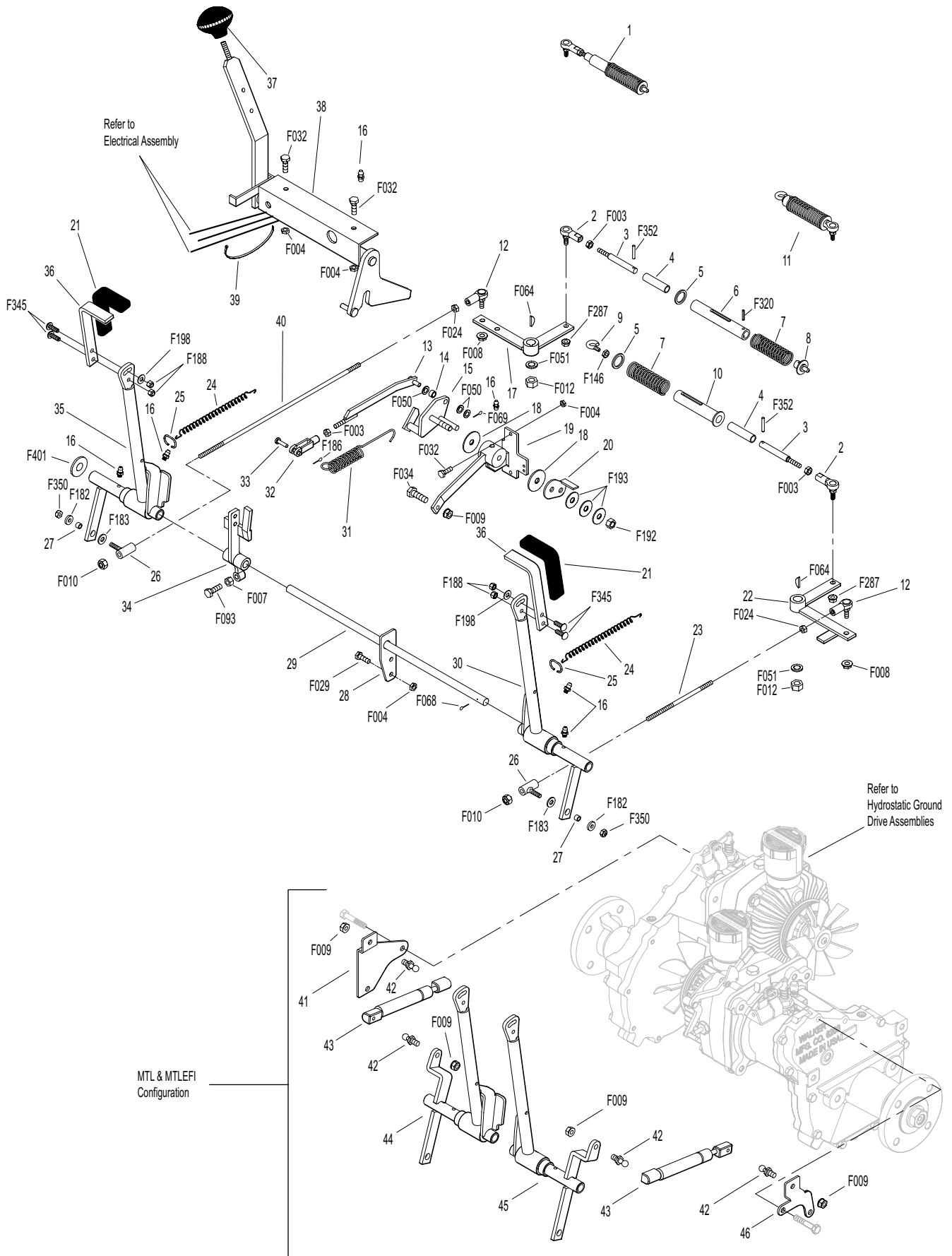

THROTTLE & CHOKE CONTROL ASSEMBLY

ITEM NO.	PART NO.	DESCRIPTION	NO. REQ'D	ITEM NO.	PART NO.	DESCRIPTION	NO. REQ'D
Throttle & Choke Control Assemblies				Fasteners			
1	8121-1	Throttle Cable	1		F004	1/4-20 Keps Nut	4
2	8122-1	Choke Cable	1		F005	1/4-20 ESNA Nut	2
3	5172	Bearing, Nylon (.255 x .379 x .250)	2		F029	1/4-20 x 1/2 Hex Bolt	4
4	5108-7	Control Lock Tab	2		F050	1/4 SAE Washer	1
5	5108-10	Friction Washer (.125)	2		F164	10-24 x 1/4 x 3/8 SHL Bolt	1
6	5108-1	Control Lever, Throttle & Choke	2		F201	1/4 Belleville Spring Washer	4
7	5108-5	Throttle Control Knob, Red	1				
8	5108-11	Friction Washer (.062)	2	*	Service Part Only		
9	5108-8	Control Bracket	2				
10	7108	Control Assembly (Includes Items # 4-6, 8, 9 & F201)	2	Δ	Model MTEFI and MTLEFI do not use choke.		
	8121	Throttle Control and Cable Assembly (Includes Item # 7)	*				
	8122	Choke Control and Cable Assembly (Includes Item # 11)	*Δ				
11	5108-6	Choke Control Knob, Black	1				
12	8123	Insulation Sleeve (3/8 x 6)	1				
13	5975-1	Cable Tie (18# x 3-3/4")	1				

THROTTLE & CHOKE CONTROL ASSEMBLY

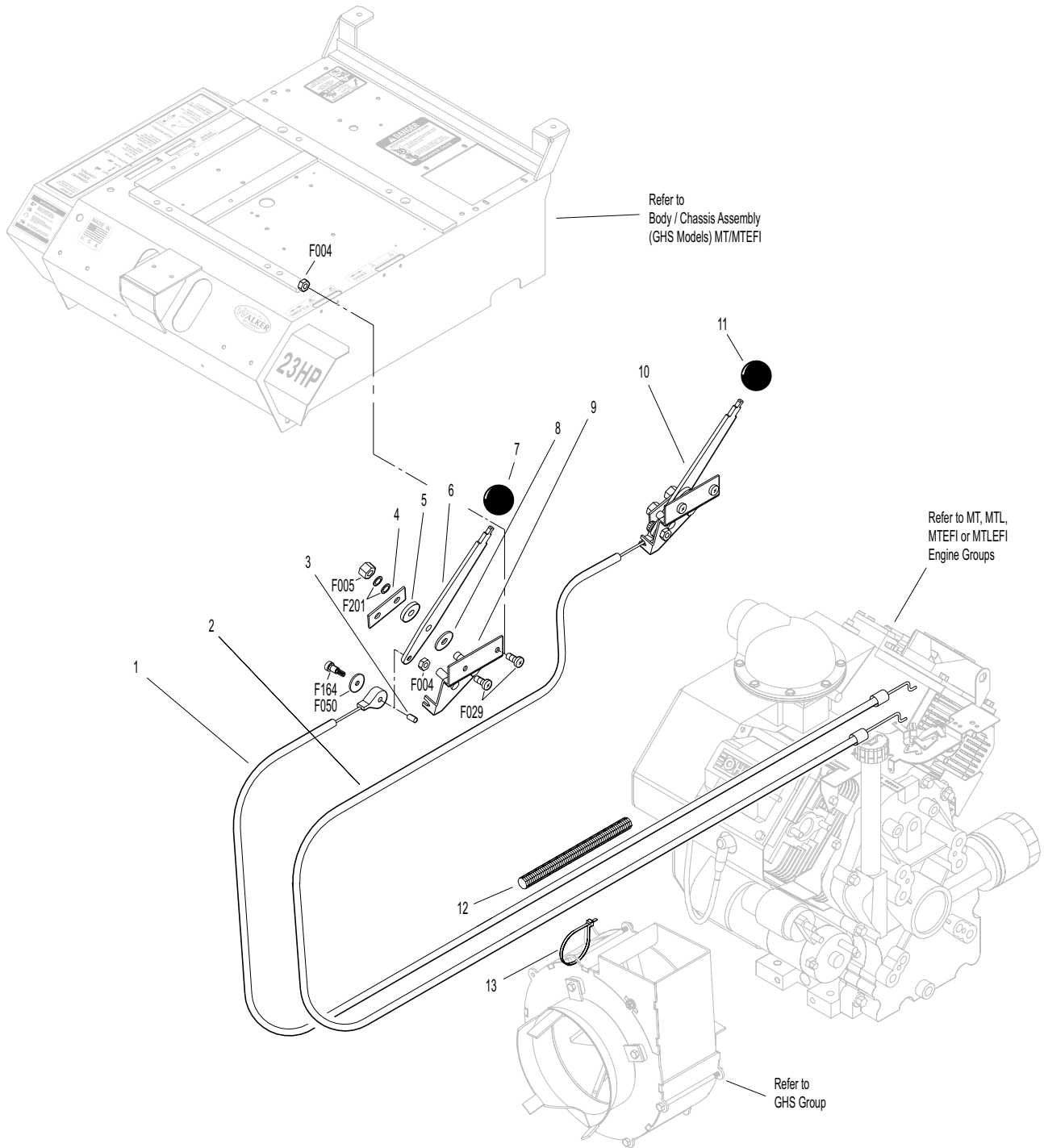

PARKING BRAKE ASSEMBLY

ITEM NO.	PART NO.	DESCRIPTION	NO. REQ'D	ITEM NO.	PART NO.	DESCRIPTION	NO. REQ'D
Parking Brake Assembly				Fasteners			
1	7406-1	Handle Grip, Red	1	F002		10-24 Keps Nut	2
2	7406-8	Parking Brake Lever (4-1/4)	1	F003		1/4-28 Hex Nut	1
3	7406-2	Lever Mount	1	F004		1/4-20 Keps Nut	4
4	5830	Grease Fitting	1	F025		10-24 x 3/8 PPHMS	2
5	7407	Clevis Pin (3/16 x 1/2)	2	F029		1/4-20 x 1/2 Hex Bolt	3
6	7404	Brake Actuator Arm	2	F032		1/4-20 x 3/4 Hex Bolt	1
7	7405	Pin, Transmission Lock	2	F054		AN960616 Washer	2
8	7402	Clevis	2	F072		1/4 "E" Retainer Ring	2
9	7408	Compression Spring (1/2 x 3/4)	2	F086		#10 SAE Washer	4
10	7415	Rubber Dust Shield (5/8 x 3/8 x 1/32)	2	F109		1/8 x 5/8 Roll Pin	2
11	5567-3	O-Ring Seal (1/4 x 3/8)	4	F111		1/8 x 3/4 Cotter Pin	1
12	7403	Plunger Bushing, Gear Axle	2	F112		5/8 x 1-1/4 x .03 Washer	2
13	7404-1	Brake Actuator Mount	2	F127		1/16 x 1/2 Cotter Pin	4
14	7412	Clevis Pin (3/16 x 5/8)	2	F261		AN960616L Washer	5
15	5833	Cable Clamp (1/4)	2	F287		1/4-28 Keps Nut	1
16	7410	Brake Control Cable, LH (25.5")	1				
17	7409	Brake Control Cable, RH (20.5")	1				
18	7401-3	Cable Mount Bracket	1				
19	7401-1	Cable Pull Rod	1				
20	5552	Ball Joint (1/4-28)	1				

PARKING BRAKE ASSEMBLY

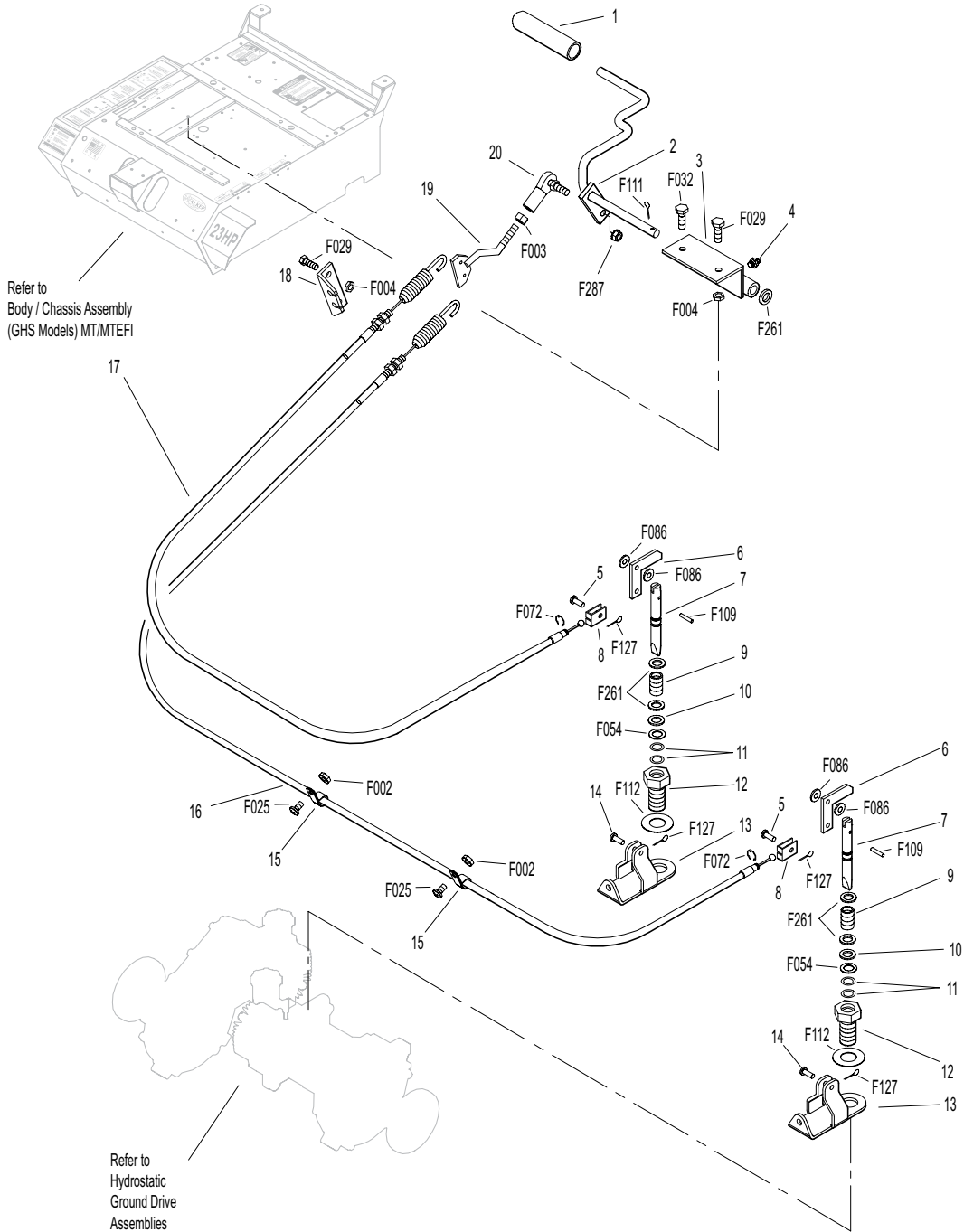

GHS GROUP

ITEM NO.	PART NO.	DESCRIPTION	NO. REQ'D
----------	----------	-------------	-----------

Delivery Chute Assembly

When Optional 7.0 Bushel Catcher Assembly is purchased, Item # 6 is replaced by P/N 7511-1 (Delivery Chute Assembly, 7.0).

1	5515-2	Elbow Delivery Spout	1
2	5592-13	Backing Plate, Grass-Pak® Switch	1
3	5592-12	Mount Plate, Grass-Pak® Switch	1
4	5578	Rear Clip, Chute Mount	1
5	5577	Side Clip, Chute Mount	2
6	8511-1	Delivery Chute W/Clips / 10.0 (Includes Items # 4, 5, 7, F362 & F411)	1
	7511-1	Delivery Chute W/Clips / 7.0 (Includes Items # 4, 5, 7, F362 & F411)	*
7	5578-10	Front Clip, Chute Mount	1
8	7530-4	Body Chute (10.5 Blower)	1

Blower Belt Tightener Assembly

9	7238-6	Blower Drive Pulley (Includes Items # F075, F114 & F231)	1
10	7234-2	Blower Belt (Micro-V)	1
11	7239-1	Blower Pulley (Mirco-V) (Includes Items # F067, F075 & F114)	1
12	7364-2	Torsion Spring	1
13	7201-3	DU Bearing	2
14	5830-3	Grease Fitting (45 Deg.)	1
15	7364-1	Blower Belt Tightener Arm	1
16	7201-4	Inner Race (1-1/2)	1
17	5841	Retainer Washer (3/8 x 1-1/4)	1
18	5245	Idler Pulley (3")	1

Blower Assembly

19	7542	Blower Assembly (10.5") (Includes Items # 20-27, F004, F029, F050, F061, F131, F132, F168, F246 & F414)	1
20	5268	Bearing W/Collar (3/4)	2
21	7542-2	Blower Back Plate (10.5)	1
22	7545-2	Blower Output Shaft (10.5)	1
23	7545	Blower Wheel (10.5")	1
24	7542-4	Blower Scroll (10.5)	1
25	7542-5	Blower Coupler Nut	1
26	7542-3	Blower Faceplate (10.5)	1
27	7526	Intake Tube (10.5 Blower)	1
28	5595-2	Intake Cover/GHS	**
29	7528-2	Skid Bar (10.5" Blower)	1

ITEM NO.	PART NO.	DESCRIPTION	NO. REQ'D
----------	----------	-------------	-----------

Fasteners

F002	10-24 Keps Nut	8
F004	1/4-20 Keps Nut	7
F009	5/16-18 Whiz Locknut	1
F012	3/8-16 Keps Nut	3
F025	10-24 x 3/8 PPHMS	2
F026	10-24 x 1/2 PPHMS	2
F029	1/4-20 x 1/2 Hex Bolt	3
F034	5/16-18 x 3/4 Hex Bolt	1
F039	3/8-16 x 1-1/4 Hex Bolt	1
F040	3/8-16 x 1-1/2 Hex Bolt	1
F042	3/8-16 x 2-1/4 Hex Bolt	1
F050	1/4 SAE Washer	1
F054	AN960616 Washer	1
F061	1/4 Star Lock Washer	2
F067	3/16 x 3/16 x 1 Key	1
F075	5/16-18 x 1/2 SQH Set Screw	2
F079	A/A66D Aluminum Pop Rivet	6
F090	1/4-20 x 2-1/2 Hex Bolt	3
F102	10-24 x 1-1/2 PTHMS	2
F114	5/16-18 x 5/8 SQH Set Screw	2
F128	10-24 x 3/8 PTHMS	4
F131	5/16-18 x 1/2 Hex Bolt	3
F132	1/4-20 x 2-3/4 Hex Bolt	1
F168	5/16 Split Lock Washer	3
F217	7/16-14 Hex Nut	1
F218	7/16 Split Lock Washer	1
F231	1/4 x 3/4 Woodruff Key (# 806)	1
F246	1/4-20 x 1/2 PTHMS	1
F281	7/16-14 x 1-3/4 Hex Bolt	1
F362	A/A62D Alum. Pop Rivet (3/16D x 13/32L)	2
F411	3/16 Bulbex Rivet	6
F414	1/4-20 x 5-1/8 Gd 5 Hex Bolt	5

* Service Part Only

** Plugs Blower when GHS is not in use. Furnished only with Mulching Decks, SD Decks used on a GHS Tractor, Rotary Broom Attachment and Snowblower Attachment. Use of this part may be replaced by installing Blower Lockout Kit (P/N 7541). See Page 84.

GHS GROUP

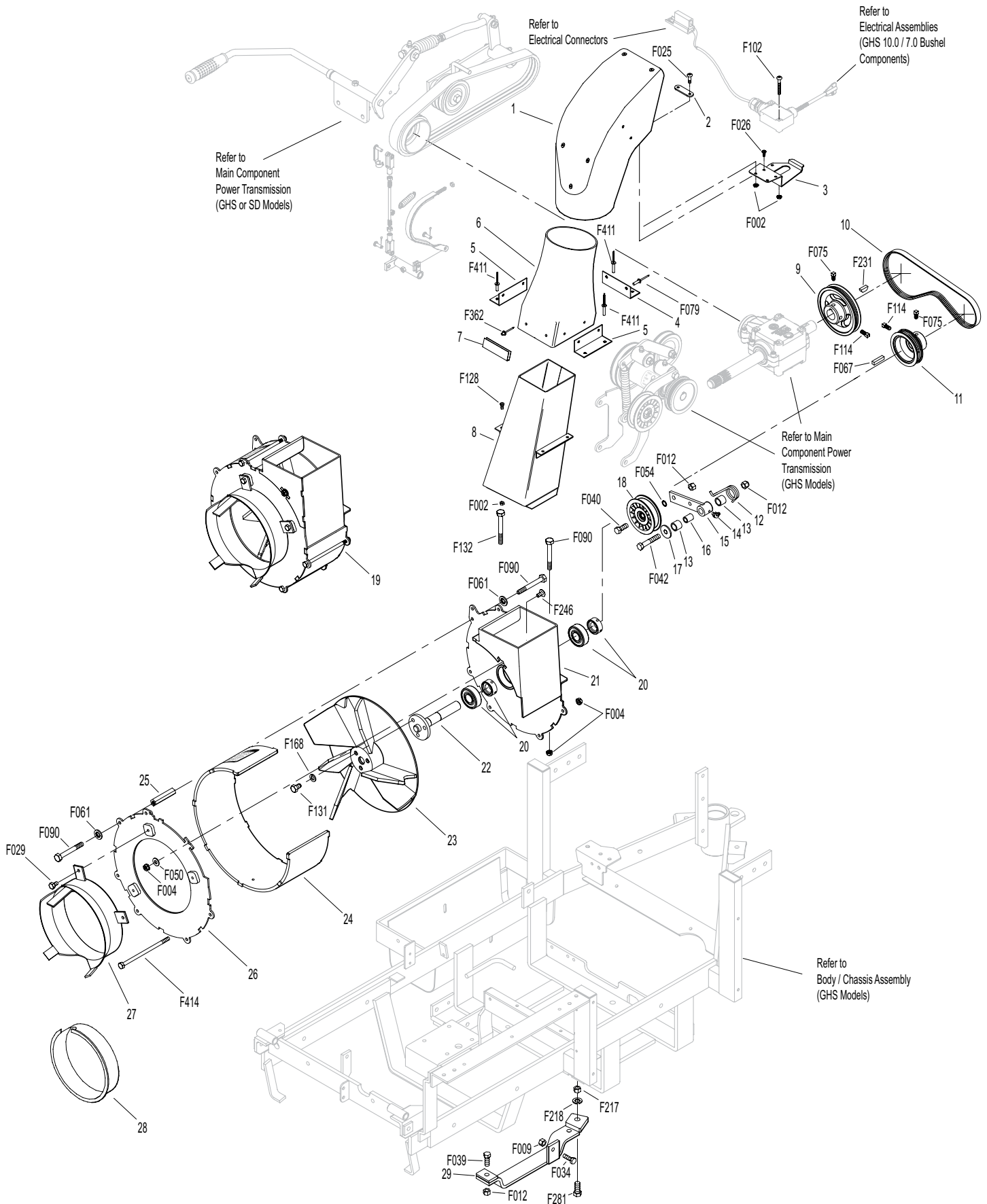

Effective Date 04-01-09

Use only genuine **Walker®** replacement parts.

GHS POWERFIL® ASSEMBLIES (10.0 / 7.0)

ITEM NO.	PART NO.	DESCRIPTION	NO. REQ'D	ITEM NO.	PART NO.	DESCRIPTION	NO. REQ'D
10.0 GHS Powerfil® Assembly				Fasteners			
1	5551-3	Bearing Cap, Powerfil®	1	F002		10-24 Keps Nut	10
2	5551-1	Pivot Bearing (#S3PP)	2	F003		1/4-28 Hex Nut	3
3	5518-2	Pivot, Delivery Spout	1	F025		10-24 x 3/8 PPHMS	1**
4	5517-2	Pivot Mount	1	F026		10-24 x 1/2 PPHMS	1***
5	5552	Ball Joint (1/4-28)	2	F037		10-24 x 5/8 PTH Screw	1
6	5558-1	Powerfil® Push Rod	1	F054		AN960616 Washer	1
7	5553-3	Bushing, Powerfil® Actuator	4	F085		3/16 Rivet Backup Washer	1
8	5553-1	Compression Spring (1/2 x 2)	2	F101		10-24 x 1-1/4 SHC Screw	1
9	5558-2	Powerfil® Actuator Rod	1	F109		1/8 x 5/8 Roll Pin	1
	5549	Actuator Rod Assembly (Includes Items # 5-9 & F003)	*	F129		10-24 x 1/2 PTHMS	7
10	5519-3	Motor Mount Nut (5/8-24)	*	F261		AN960616L Washer	1
11	5554	Actuator Arm	1	F287		1/4-28 Keps Nut	1
12	5519-2	Motor Mount Washer	*				
13	5976-2	Grommet (3/16 x 3/4)	1				
14	5519	Actuator Motor (12/24V) (Includes Items # 10 & 12)	1				
7.0 GHS Powerfil® Assembly							
1	5551-3	Bearing Cap, Powerfil®	1				
2	5551-1	Pivot Bearing (#S3PP)	2				
3	5518-2	Pivot, Delivery Spout	1				
4	5517-2	Pivot Mount	1				
5	5552	Ball Joint (1/4-28)	2				
6	5558-1	Powerfil® Push Rod	1				
7	5553-3	Bushing, Powerfil® Actuator	4				
8	5553-1	Compression Spring (1/2 x 2)	2				
9	5558-2	Powerfil® Actuator Rod	1				
	5549	Actuator Rod Assembly (Includes Items # 5-9 & F003)	*				
10	5519-3	Motor Mount Nut (5/8-24)	*				
11	5554	Actuator Arm	1				
12	5519-2	Motor Mount Washer	*				
14	5519	Actuator Motor (12/24V) (Includes Items # 10 & 12)	1				
15	5977	Grommet (1/2 x 7/8 x 1/16)	1				
16	5557	Motor Mount, Powerfil®	1				

* Service Part Only

** Item used on 7.0 models only

*** Item used on 10.0 models only

GHS 10.0 BUSHEL CATCHER ASSEMBLY

ITEM NO.	PART NO.	DESCRIPTION	NO. REQ'D	ITEM NO.	PART NO.	DESCRIPTION	NO. REQ'D
Upper Baffle Screen Assembly (Removable)				44	5523-6	Gas Spring Plate	2
1	7512-2	Removable Screen (3/16 Hole) (Includes Items # 2, 5, F025 & F190)	1**	45	8608-10	Box Support, Gas Spring	2
2	7506	Knob/Threaded Insert (10-24)	2	46	7532	Handle, Catcher Lift	2
3	8606-3	Channel Top, LH	1	47	7533	Backing Plate, Handle	2
4	8606-2	Channel Bottom	2	48	5976	Grommet (3/8 x 11/16)	2
5	7856-1	Edge Molding (26")	1	49	8117	Wire Harness Channel	1
6	7507	Screen Seal (27-1/2)	1	50	8602-1	10.0 Catcher W/O Powerfil® (Includes Door) *	*
7	7505	Mustache Spring	2		8602-2	10.0 Catcher W/Powerfil® (Includes Door) *	*
8	8606	C-Channel (10.0)	1		8610-2	10.0 Bushel Catcher Box	*
	8606-20	C-Channel With Spring (10.0) (Includes Items # 7, 8 & F340)	*	51	8607-9	Powerfil® Cover Plate	1
9	8606-4	Channel Top, RH	1	52	8155-2	Gas Spring Cover, RH	1
10.0 Exhaust Deflector Door Assembly				53	8608-8	Hinge Plate, RH	1
10	8607-6	Upper Seal Support	1	54	8608-9	Torsion Bar	1
11	8607-5	Upper Door Seal	1	5598 Optional Dump Bag (Not Shown)			
12	8607-11	Backup Plate	1	May be ordered as an option. Contact your Walker dealer.			
13	8512-3	10.0 Catcher Box Door (Includes Items # 10-14, F085, F330 & F411)	1	Fasteners			
14	5583	Handle	1	F002	10-24 Keps Nut		27
15	8607-1	Door Mount, LH	1	F004	1/4-20 Keps Nut		25
16	8607-12	Upper Door Stiffener	1	F009	5/16-18 Whiz Locknut		6
17	8607-7	Lower Door Stiffener	1	F024	5/16-24 Jam Nut		4
18	8607-8	Door Guide	1	F025	10-24 x 3/8 PPHMS		4
19	8607-2	Door Mount, RH	1	F026	10-24 x 1/2 PPHMS		2
GHS 10.0 Bushel Catcher Assembly				F027	10-24 x 5/8 PPHMS		6
20	8608-5	Center Strap	1	F029	1/4-20 x 1/2 Hex Bolt		8
21	8608-3	Upper Frame Doubler	2	F049	5/16 SAE Washer		8
22	8610	Catcher Dump Plate	1	F050	1/4 SAE Washer		2
23	8608-2	Lower Frame Doubler	2	F068	1/8 x 1 Cotter Pin		2
24	5281-5	Clevis Pin (1/4 x 0.80)	2	F069	3/32 x 1/2 Cotter Pin		2
25	7610-1	Dump Plate Slide	2	F079	A/A66D Aluminum Pop Rivet		14
26	8608-11	Catcher Door Finger	1	F085	3/16 Rivet Backup Washer		14
27	8608-4	Center Frame Doubler	1	F094	8-32 x 1/2 PTHMS		6
28	8608-6	Catcher Mount	1	F129	10-24 x 1/2 PTHMS		17
29	8608-1	Outside Box Strap	2	F172	1/4-20 x 3/4 Carriage Bolt		4
30	7584	Reinforcing Strap	1	F190	#10 Internal Star Lock Washer		2
31	5103-5	Pivot Bushing Inner	2	F195	1/4-20 x 3/4 PPHMS, SS		8
32	7620-3	Pivot Bushing (1/2 x 9/16)	2	F196	1/4-20 x 1 PPHMS, SS		4
33	8608-7	Hinge Plate, LH	1	F208	5/16-18 x 2-1/4 Hex Bolt		2
34	5103-7	Outside Torsion Bushing	2	F228	#6 x 5/8 PPHSMS, SS		2
35	8607-4	Upper Arm	2	F230	1/4-20 x 1-1/4 PPHMS, SS		1
36	5214-12	Ball Joint (5/16-24)	4	F242	1/4-20 x 7/8 PPHMS, SS		8
37	5155-12	5/16 Ball Stud	2	F330	3/16D x 21/32L Rivet, SS		9
38	5155-4	Gas Spring	2	F340	Rivet, Aluminum		4
39	5147	Spring Clip	4	F351	Aluminum Pop Rivet		6
40	8155-1	Gas Spring Cover, LH	1	F360	1/4-20 x 3/8 Hex Bolt		4
41	8607-3	Lower Arm	2	F411	3/16 Bulbex Rivet		10
42	5103-6	Pivot Bushing Outer	2	F456	5/16-18 x 3/4 SBH Cap Screw, SS		4
43	5155-13	3/4 Ball Stud	2	* Service Part Only			
				** This screen can be replaced by P/N 7512-3 Removable Screen (3/4" holes) for improved air flow performance in wet conditions.			

Use only genuine **Walker®** replacement parts.

Effective Date 04-01-09

GHS 7.0 BUSHEL CATCHER & EXHAUST DEFLECTOR ASSEMBLIES

ITEM NO.	PART NO.	DESCRIPTION	NO. REQ'D	ITEM NO.	PART NO.	DESCRIPTION	NO. REQ'D
Upper Baffle Screen Assembly (Removable)				32	7532	Handle, Catcher Lift	2
					7534	Catcher Handle Kit (Includes Items # 32, 33, F004 & F172)	*
1	7509-3	Channel Bottom	2	33	7533	Backing Plate, Handle	2
2	7505	Mustache Spring	2	34	5155-15	Box Support, Gas Spring	2
3	7507	Screen Seal (27-1/2)	1	35	7557-10	7.0 Wire Harness Channel	1
4	7856-1	Edge Molding (26")	1	36	5976	Grommet (3/8 x 11/16)	1
5	7509-2	Channel Top	2	37	5976-2	Grommet (3/16 x 3/4)	1
6	7512-2	Removable Screen (3/16 Holes) (Includes Items # 7, F025 & F190)	1**	38	5522-2	Hinge Backup Plate, RH	1
7	7506	Knob/Threaded Insert (10-24)	2	39	7508	Safety Latch Kit (7.0/9.5)	1
8	7509-4	C-Channel	1				
Exhaust Deflector Assembly				5598 Optional Dump Bag (Not Shown)			
9	7504-3	Hinge (27")	1	May be ordered as an option. Contact your Walker dealer. Not used with Power Dump Option.			
10	7504-1	Exhaust Deflector (Two Piece Set)	1				
	7504	Exhaust Deflector Kit	*				
11	7504-8	Deflector Mount Doubler	2	Fasteners			
GHS 7.0 Bushel Catcher Assembly				F002	10-24 Keps Nut		26
May be ordered as a factory-installed option. Contact your Walker dealer.				F004	1/4-20 Keps Nut		18
12	7503	Mounting Frame (7.0) (Includes Item # 23)	1	F009	5/16-18 Whiz Locknut		2
13	7510-1	7.0 Bushel Catcher, Including Door	1	F020	5/16-18 ESNA Nut		2
	7502-1	7.0 Catcher (Without Powerfil®) (Includes Door & Deflector)	*	F025	10-24 x 3/8 PPHMS		4
	7502-2	7.0 Catcher (With Powerfil®) (Includes Door & Deflector)	*	F026	10-24 x 1/2 PPHMS		8
14	7514-1	Backup Plate	1	F027	10-24 x 5/8 PPHMS		4
15	5583	Handle	1	F035	5/16-18 x 1-1/4 Hex Bolt		1
16	5588	Rubber Bumper (.75 x .50)	2	F037	10-24 x 5/8 PTH Screw		6
17	7522	Side Strap, Door (7.0)	2	F049	5/16 SAE Washer		4
18	7513-2	7.0 Mounting Frame Doubler	1	F069	3/32 x 1/2 Cotter Pin		2
19	7512-10	Deflector Seal	1	F079	A/A66D Aluminum Pop Rivet		*
20	5281-5	Clevis Pin (1/4 x 0.80)	2	F085	3/16 Rivet Backup Washer		*
21	7584	Reinforcing Strap	2	F129	10-24 x 1/2 PTHMS		8
22	5522-1	Hinge Backup Plate, LH	1	F172	1/4-20 x 3/4 Carriage Bolt		4
23	7503-9	Pivot Bushing (5/16 x 5/8)	2	F188	1/4-20 Self-Locking Nut		11
24	7514-10	7.0 Door Frame, Catcher	1	F190	#10 Internal Star Lock Washer		2
25	5155-12	5/16 Ball Stud	2	F195	1/4-20 x 3/4 PPHMS, SS		14
26	5147	Spring Clip	4	F196	1/4-20 x 1 PPHMS, SS		4
27	5155-2	Gas Spring Cover	2	F198	.250 x .625 x .040 Washer, SS		8
28	5155	Gas Spring Assembly / Catcher Door (Includes Items # 25, 26, 30 & F049)	2	F230	1/4-20 x 1-1/4 PPHMS, SS		1
29	5524-1	Flanged Hinge Bearing	2	F242	1/4-20 x 7/8 PPHMS, SS		9
30	5155-13	3/4 Ball Stud	2	F252	10-24 x 3/4 PPHMS		1
31	5523-6	Gas Spring Plate	2	F255	5/16-18 x 1-1/2 Hex Bolt		1
				F329	.200 ID x 1.939 OD Washer		2
				F330	3/16 D x 21/32 L Rivet, SS		2
				F340	Rivet, Aluminum		4
				F351	Aluminum Pop Rivet		6
				* Service Part Only			
				** This screen can be replaced by P/N 7512-3 Removable Screen (3/4" hole) for improved air flow performance in wet conditions.			

Use only genuine **Walker®** replacement parts.

Effective Date 04-01-09

GHS 7.0 BUSHEL CATCHER & EXHAUST DEFLECTOR ASSEMBLIES

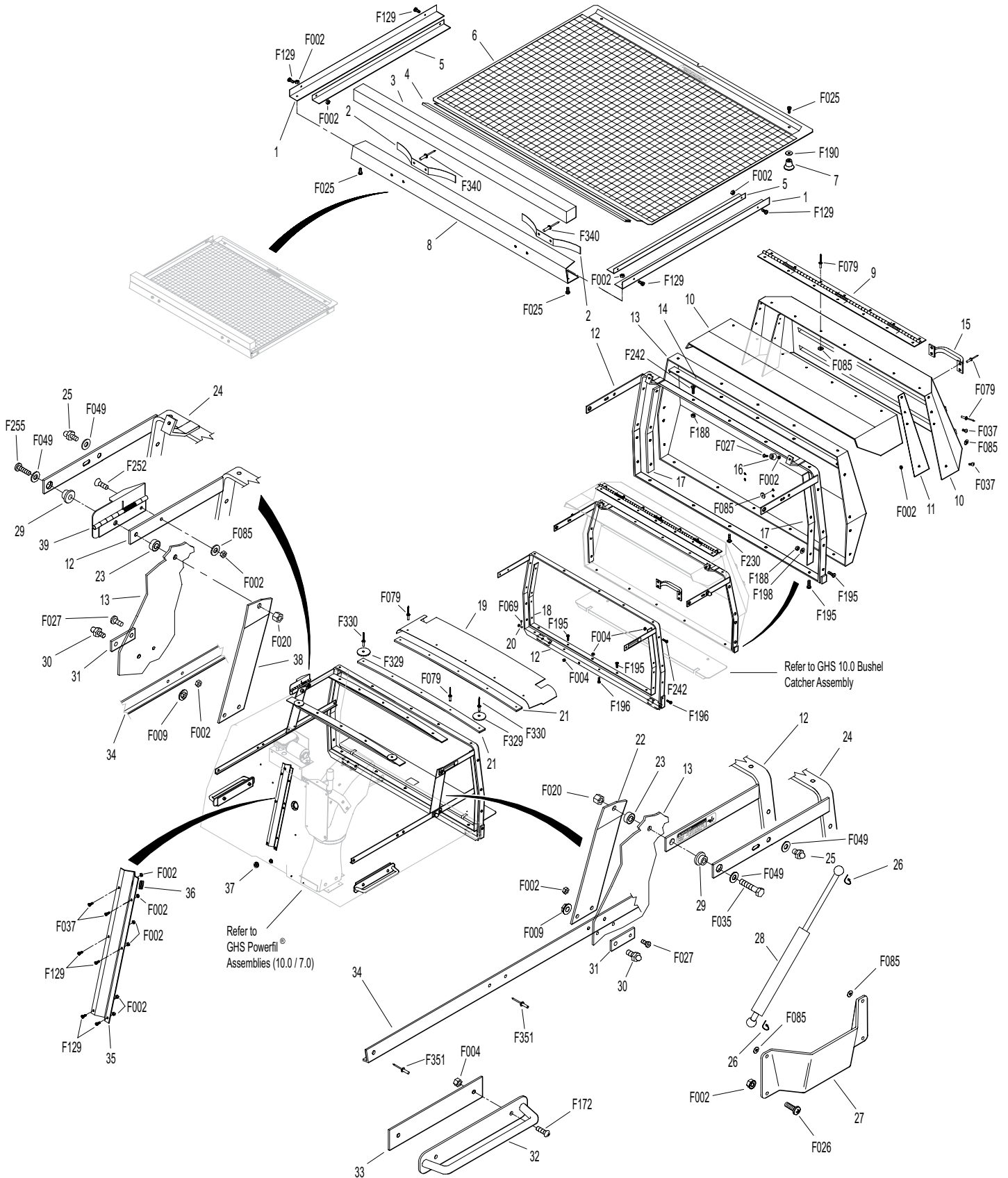

Effective Date 04-01-09

Use only genuine **Walker®** replacement parts.

INSTRUMENT PANEL ASSEMBLY (MT)

ITEM NO.	PART NO.	DESCRIPTION	NO. REQ'D	ITEM NO.	PART NO.	DESCRIPTION	NO. REQ'D
Instrument Panel Assembly				20	6941-6	Relay Switch 30/40AMP	*
1	7307-2	Instrument Panel Cover (Optional)	**	21	6941-7	Relay Mount	*
	8306-4	Instrument Panel Assembly (Includes Items # 2-12, 14, 22-24, 26-28, F228, F250, F251 & F349)	1	22	8536	Warning Horn	1
2	7307	Panel Frame	1	23	8960-15	Ignition Switch (with Keys) (Includes Items # 25, 26 & F349)	1
3	8823-2	Decal, Instrument Panel	1	24	8996-2	Red Indicator Light Assembly (Includes Items # 27 & 28)	2
4	8820-13	Panel Faceplate	1	25	7854	Plastic Tip, Red	1
5	7386	Panel Gasket	1	26	8960-3	Key Set W/Umbrella	*
6	6942	Relay Switch (30/40 Amp) NC (Includes Items # 20 & 21)	2	27	8996-4	Red Indicator Lens	2
7	7941-3	Boot, Circuit Breaker	1	28	8996-3	Indicator Bulb (Replacement for P/N 8996-2)	*
8	7941-5	Circuit Breaker (7 Amp)	1	Fasteners			
9	5995-2	Switch Boot	1	F004	1/4-20 Keps Nut		6
10	5995	Toggle Switch (Off-On)	1	F228	#6 x 5/8 PPHSMS, SS		8
11	8997	Voltmeter Gauge	1	F238	J Clip, Instrument Panel		8
12	8990-1	Hourmeter (SenDec)	1	F250	6-32 x 1/2 PPHMS		2
13	5975-1	Cable Tie (18# x 3-3/4")	2	F251	6-32 Keps Nut		2
14	8945-3	Wire Harness, Instrument Panel	1	F349	Washer .835 ID 1.122 OD, SS		1
15	7307-16	Lining, Panel Box (1/8)	1	* Service Part Only			
16	7391	Panel Box Mount Plate	2	** May be ordered as an option. Contact your Walker dealer.			
17	7977-1	Grommet (1/8 x 1-1/16)	1				
18	7307-1	Shock Mount (1.0 x .25)	3				
19	8385	Panel Box W/Graphic	1				

NOTE: Refer to **ELECTRICAL CONNECTORS**, Page 64 for identification of all Electrical Wiring Service Parts.

INSTRUMENT PANEL ASSEMBLY (MT)

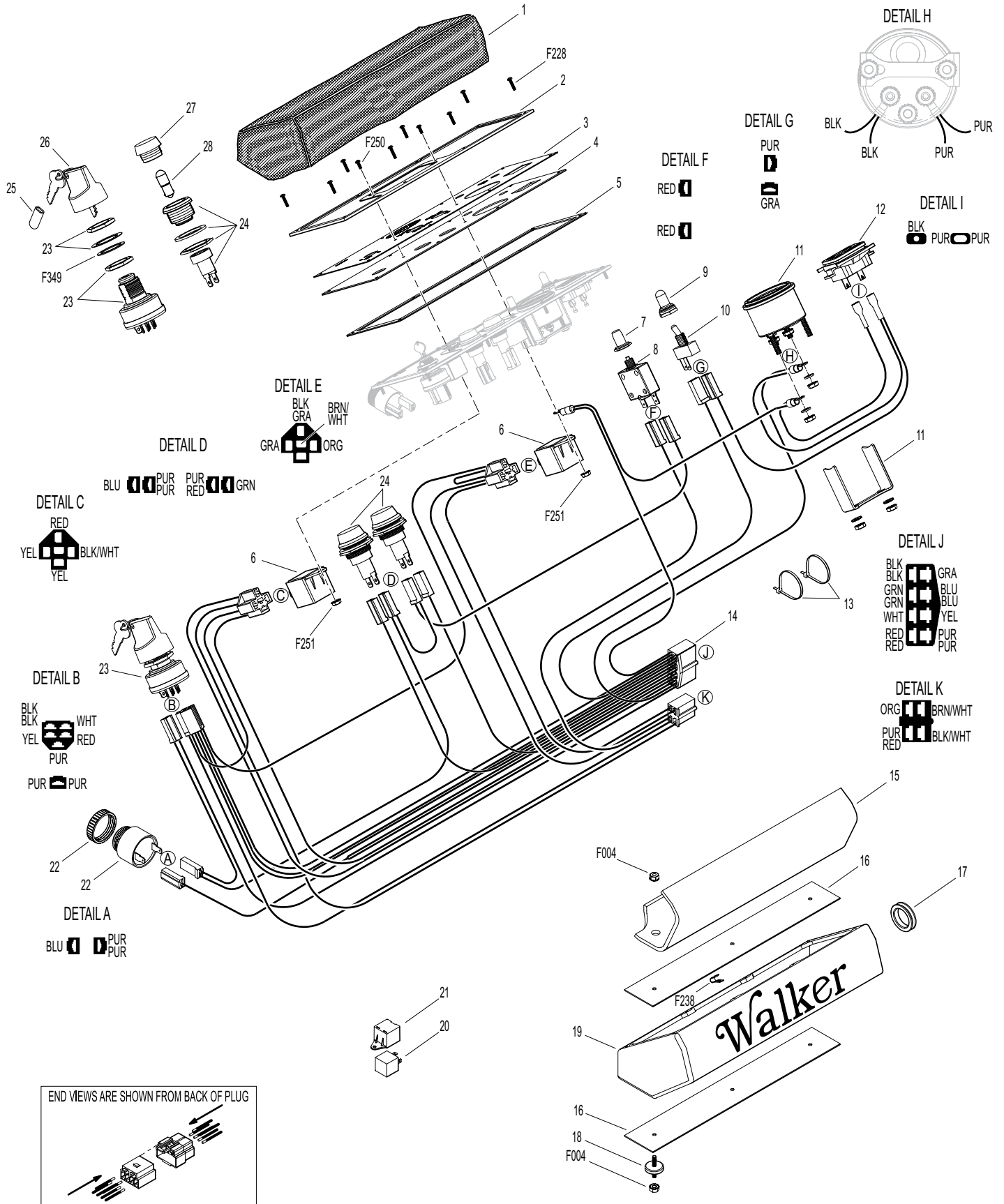

Effective Date 04-01-09

Use only genuine Walker® replacement parts.

INSTRUMENT PANEL ASSEMBLY (MTL)

ITEM NO.	PART NO.	DESCRIPTION	NO. REQ'D	ITEM NO.	PART NO.	DESCRIPTION	NO. REQ'D
Instrument Panel Assembly				22	6941-7	Relay Mount	*
1	7307-2	Instrument Panel Cover (Optional)	**	23	6941-6	Relay Switch 30/40AMP	*
	8306-6	Instrument Panel Assembly (Includes Items # 2-20, 29, 30, F129, F228, F250, F251, F349 & F448)	1	24	7307-1	Shock Mount (1.0 x .25)	3
2	7307	Panel Frame	1	25	7391	Panel Box Mount Plate	2
3	8823-4	Decal, Instrument Panel	1	26	8385	Panel Box W/Graphic	1
4	8820-2	Panel Faceplate	1	27	7977-1	Grommet (1/8 x 1-1/16)	1
5	7386	Panel Gasket	1	28	7307-16	Lining, Panel Box (1/8)	1
6	8960-15	Ignition Switch (with Keys) (Includes Items # 20, 21 & F349)	1	29	8536	Warning Horn	1
7	8996-2	Red Indicator Light Assembly (Includes Items # 18 & 19)	2	30	6942	Relay Switch (30/40 Amp) NC (Includes Items # 22 & 23)	3
8	7941-3	Boot, Circuit Breaker	2	Fasteners			
9	7941-5	Circuit Breaker (7 Amp)	1	F002	10-24 Keps Nut		1
10	7941-2	Circuit Breaker (10 Amp)	1	F004	1/4-20 Keps Nut		6
11	8990-1	Hourmeter (SenDec)	1	F129	10-24 x 1/2 PTHMS		1
12	5995	Toggle Switch (Off-On)	1	F228	#6 x 5/8 PPHSMS, SS		8
13	5995-2	Switch Boot	1	F238	J Clip, Instrument Panel		8
14	7306-14	Water Temperature Gauge	1	F250	6-32 x 1/2 PPHMS		1
15	8997	Voltmeter Gauge	1	F251	6-32 Keps Nut		2
16	8945-4	Wire Harness, Instrument Panel	1	F349	Washer .835 ID, 1.122 OD, SS		1
17	5975-1	Cable Tie (18# x 3-3/4")	2	F448	6-32 x 5/16 PPHMS		1
18	8996-4	Red Indicator Lens	2	* Service Part Only			
19	8996-3	Indicator Bulb (Replacement for P/N 8996-2)	*	** May be ordered as an option. Contact your Walker dealer.			
20	8960-3	Key Set W/Umbrella	*	NOTE: Refer to ELECTRICAL CONNECTORS , Page 64 for identification of all Electrical Wiring Service Parts.			
21	7854	Plastic Tip, Red	1				

INSTRUMENT PANEL ASSEMBLY (MTL)

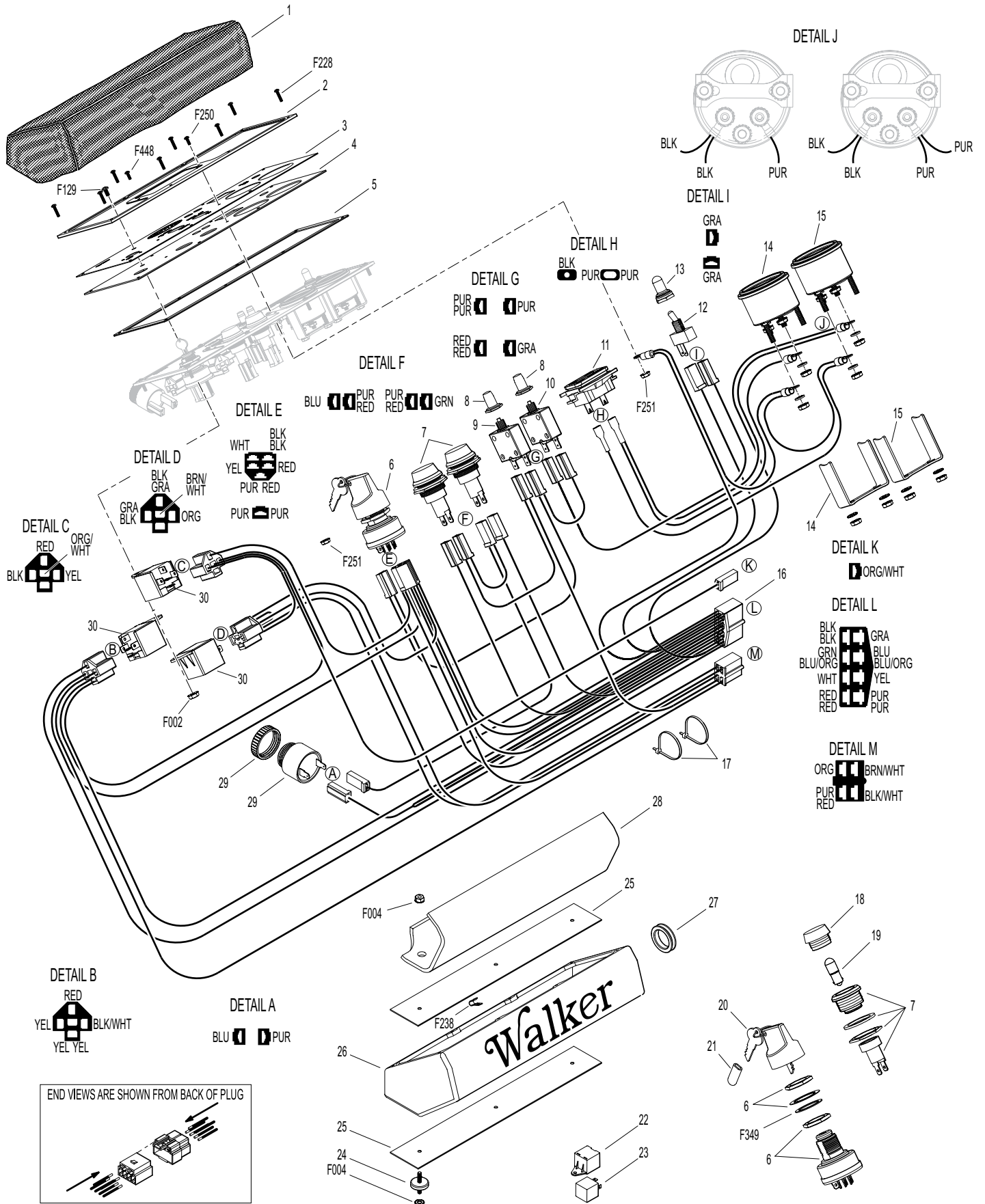

Effective Date 04-01-09

Use only genuine Walker® replacement parts.

INSTRUMENT PANEL ASSEMBLY (MTEFI)

ITEM NO.	PART NO.	DESCRIPTION	NO. REQ'D	ITEM NO.	PART NO.	DESCRIPTION	NO. REQ'D
Instrument Panel Assembly				21	8996-10	Amber Indicator Light Assembly (Includes Items # 16 & 20)	1
1	7307-2	Instrument Panel Cover (Optional)	**	22	7307-1	Shock Mount (1.0 x .25)	3
	8306-5	Instrument Panel Assembly (Includes Items # 2-12, 14-21, 29, 30, F228, F250, F251, F349 & F448)	1	23	7391	Panel Box Mount Plate	2
2	7307	Panel Frame	1	24	8385	Panel Box W/Graphic	1
3	8823-3	Decal, Instrument Panel	1	25	7977-1	Grommet (1/8 x 1-1/16)	1
4	8820-16	Panel Faceplate	1	26	7307-16	Lining, Panel Box (1/8)	1
5	7386	Panel Gasket	1	27	6941-6	Relay Switch 30/40AMP	*
6	8996-2	Red Indicator Light Assembly	2	28	6941-7	Relay Mount	*
7	8990-1	Hourmeter (SenDec)	1	29	8536	Warning Horn	1
8	5995-2	Switch Boot	1	30	8997	Voltmeter Gauge	1
9	5995	Toggle Switch (Off-On)	1	Fasteners			
10	6942	Relay Switch (30/40 Amp) NC (Includes Items # 27 & 28)	2	F004	1/4-20 Keps Nut		6
11	7941-3	Boot, Circuit Breaker	1	F228	#6 x 5/8 PPHSMS, SS		8
12	7941-5	Circuit Breaker (7 Amp)	1	F238	J Clip, Instrument Panel		8
13	5975-1	Cable Tie (18# x 3-3/4")	2	F250	6-32 x 1/2 PPHMS		1
14	8945-3	Wire Harness, Instrument Panel	1	F251	6-32 Keps Nut		2
15	8996-4	Red Indicator Lens	2	F349	Washer .835 ID, 1.122 OD, SS		1
16	8996-3	Indicator Bulb (Replacement for P/N 8996-2)	*	F448	6-32 x 5/16 PPHMS		1
17	8960-3	Key Set W/Umbrella	*	* Service Part Only			
18	7854	Plastic Tip, Red	1	** May be ordered as an option. Contact your Walker dealer.			
19	8960-15	Ignition Switch (with Keys) (Includes Items # 17, 18 & F349)	1	NOTE: Refer to ELECTRICAL CONNECTORS , Page 64 for identification of all Electrical Wiring Service Parts.			
20	8996-6	Amber Indicator Lens	1				

INSTRUMENT PANEL ASSEMBLY (MTEFI)

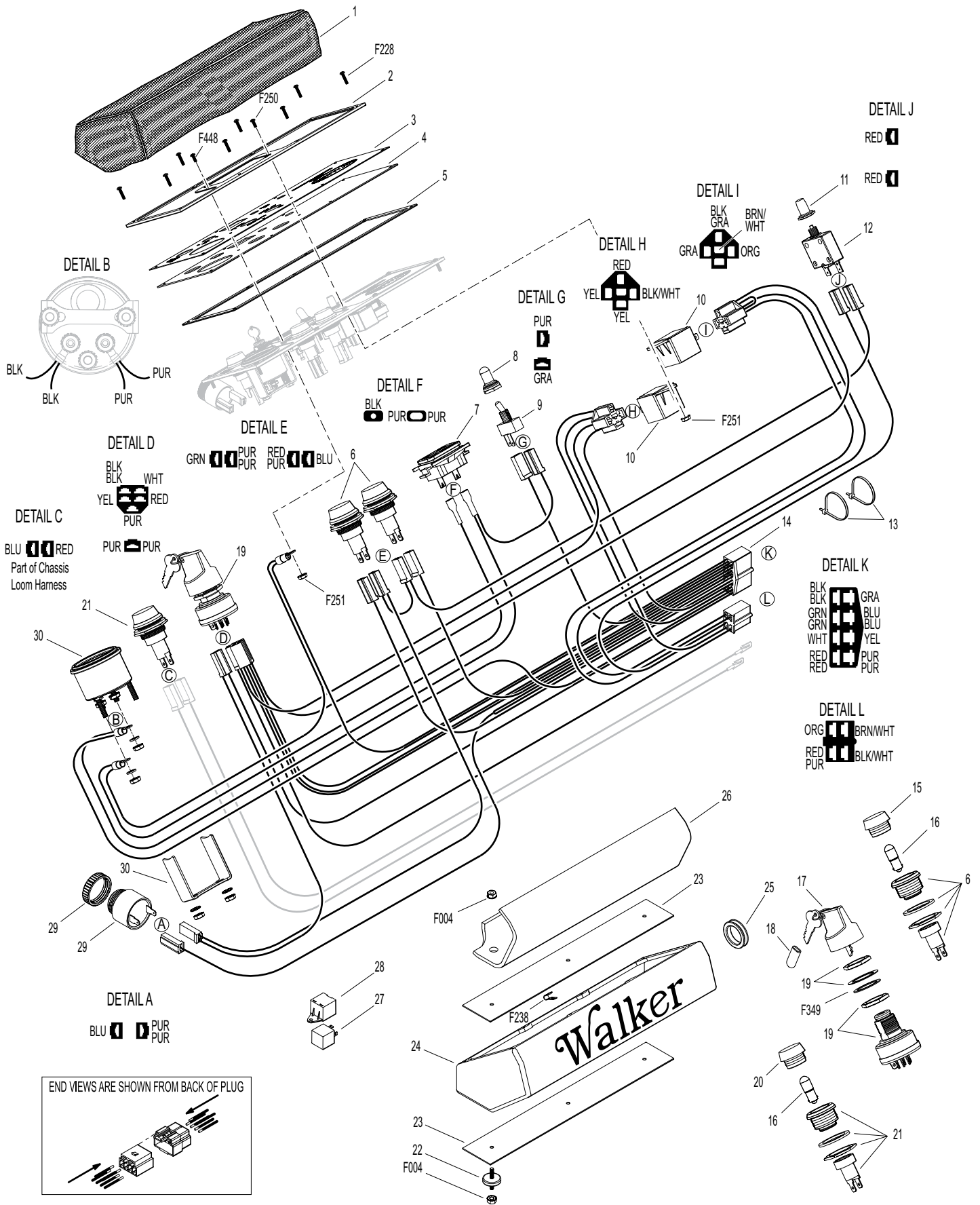

Effective Date 04-01-09

Use only genuine Walker® replacement parts.

INSTRUMENT PANEL ASSEMBLY (MTLEFI)

ITEM NO.	PART NO.	DESCRIPTION	NO. REQ'D	ITEM NO.	PART NO.	DESCRIPTION	NO. REQ'D
Instrument Panel Assembly				21	8996-10	Amber Indicator Light Assembly (Includes Items # 19 & 20)	1
1	7307-2	Instrument Panel Cover (Optional)	**	22	8960-3	Key Set W/Umbrella	*
	8306-7	Instrument Panel Assembly (Includes Items # 2-16, 18-21, 29, 30, F129, F228, F250, F251 & F349)	1	23	7854	Plastic Tip, Red	1
2	7307	Panel Frame	1	24	7307-1	Shock Mount (1.0 x .25)	3
3	8823-5	Decal, Instrument Panel	1	25	7391	Panel Box Mount Plate	2
4	8820-3	Panel Faceplate	1	26	8385	Panel Box W/Graphic	1
5	7386	Panel Gasket	1	27	7977-1	Grommet (1/8 x 1-1/16)	1
6	8960-15	Ignition Switch (with Keys) (Includes Items # 22, 23 & F349)	1	28	7307-16	Lining, Panel Box (1/8)	1
7	8996-2	Red Indicator Light Assembly (Includes Items # 18 & 19)	2	29	8536	Warning Horn	1
8	7941-3	Boot, Circuit Breaker	2	30	6942	Relay Switch (30/40 Amp) NC (Includes Items # 31 & 32)	3
9	7941-5	Circuit Breaker (7 Amp)	1	31	6941-6	Relay Switch 30/40AMP	*
10	7941-2	Circuit Breaker (10 Amp)	1	32	6941-7	Relay Mount	*
11	8990-1	Hourmeter (SenDec)	1	Fasteners			
12	5995	Toggle Switch (Off-On)	1	F002	10-24 Keps Nut		3
13	5995-2	Switch Boot	1	F004	1/4-20 Keps Nut		6
14	7306-14	Water Temperature Gauge	1	F129	10-24 x 1/2 PTHMS		1
15	8997	Voltmeter Gauge	1	F228	#6 x 5/8 PPHSMS, SS		8
16	8945-5	Wire Harness, Instrument Panel	1	F238	J Clip, Instrument Panel		8
17	5975-1	Cable Tie (18# x 3-3/4")	2	F250	6-32 x 1/2 PPHMS		2
18	8996-4	Red Indicator Lens	2	F251	6-32 Keps Nut		2
19	8996-3	Indicator Bulb (Replacement for P/N 8996-2)	*	F349	Washer .835 ID, 1.122 OD, SS		1
20	8996-6	Amber Indicator Lens	1	* Service Part Only			

** May be ordered as an option. Contact your Walker dealer.

NOTE: Refer to **ELECTRICAL CONNECTORS**, Page 64 for identification of all Electrical Wiring Service Parts.

INSTRUMENT PANEL ASSEMBLY (MTLEFI)

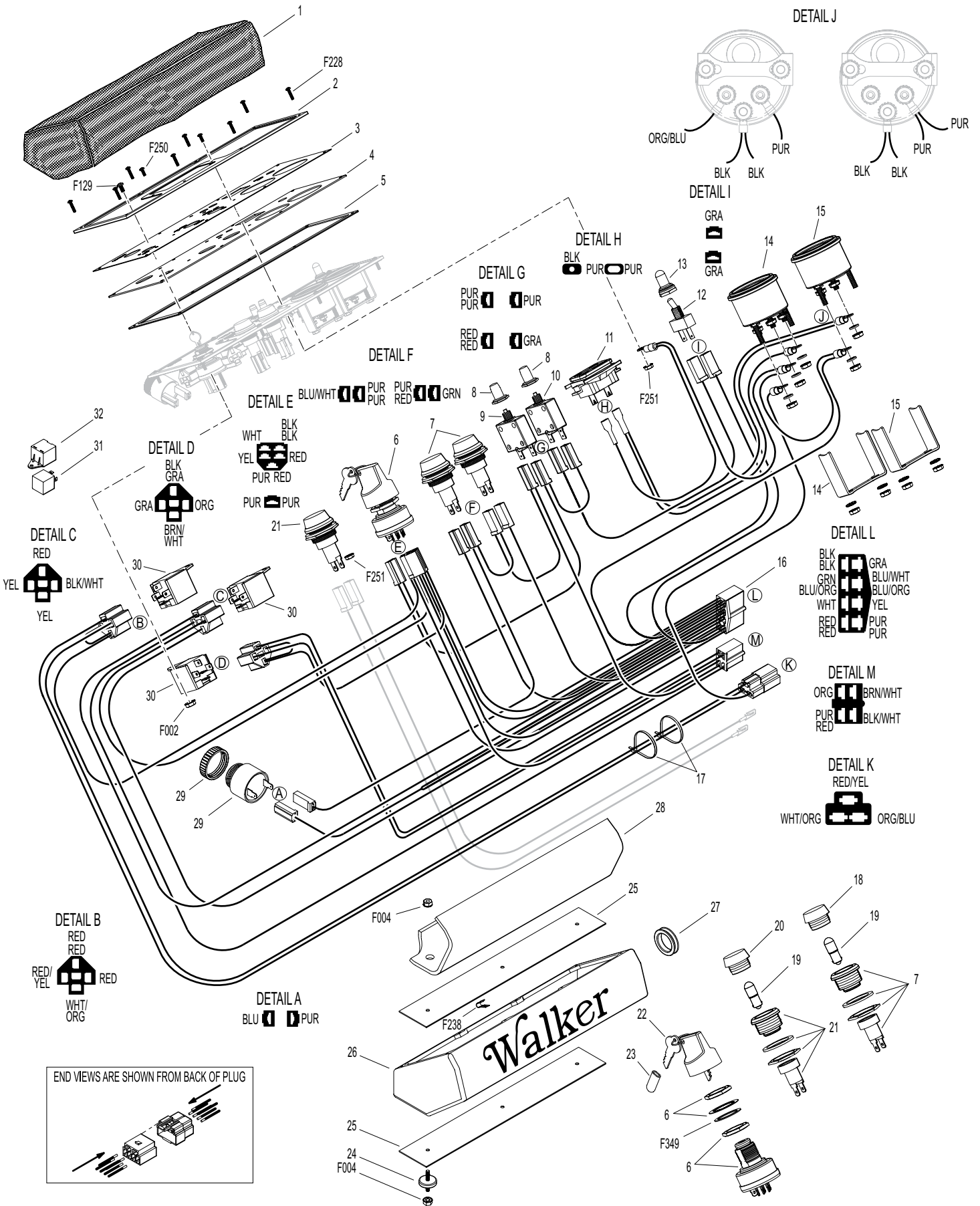

Effective Date 04-01-09

Use only genuine Walker® replacement parts.

ELECTRICAL ASSEMBLY (MT)

ITEM NO.	PART NO.	DESCRIPTION	NO. REQ'D	ITEM NO.	PART NO.	DESCRIPTION	NO. REQ'D
Harness Assembly				Fasteners			
1	5975-3	Cable Tie (50# x 7")	6	F002		10-24 Keps Nut	10
2	5942-4	PTO Safety Switch (Normal Open)	1	F004		1/4-20 Keps Nut	4
3	5833	Cable Clamp (1/4)	1	F009		5/16-18 Whiz Locknut	1
4	8940-3	Wire Harness	1	F019		1/4-20 ESNA Wing Nut	2
5	5832	Cable Clamp (1/2)	5	F025		10-24 x 3/8 PPHMS	4
6	8950	Wire Harness (9.5/10.0)	1*	F026		10-24 x 1/2 PPHMS	3
	7944	Wire Harness (7.0)	1*	F031		1/4-20 x 5/8 Hex Bolt	2
7	8012-6	Regulator Adapter Harness	1	F032		1/4-20 x 3/4 Hex Bolt	2
8	7833-2	Cable Clamp (1 x 1/4)	2	F050		1/4 SAE Washer	4
9	6942	Relay Switch (30/40 Amp) NC (Includes Items # 19 & 20)	1	F061		1/4 Star Lock Washer	1
10	7948-1	Time Delay Module	1	F079		A/A66D Aluminum Pop Rivet	4
11	7948-5	Time Delay Harness	1	F085		3/16 Rivet Backup Washer	1
12	8941	Circuit Breaker (30 Amp) Auto Reset/Sealed	1	F093		5/16-18 x 1 Hex Bolt	1
13	8943	Positive Battery Lead Wire (Red)	1	F124		10-32 x 3/8 Taptite Machine Screw	2
14	5942-5	Safety Switch (Normal Open)	1	F129		10-24 x 1/2 PTHMS	1
15	5975-1	Cable Tie (18# x 3-3/4")	3	F232		10-32 Keps Nut	2
16	5941-5	Safety Switch (Normal Open)	1	F284		M6 x 1.0 x 8 SCH Screw	1
17	7203-6	Riser Plate, Seat Switch	1				
18	5977-6	Grommet (1 x 1-1/4)	1				
19	6941-7	Relay Mount	**				
20	6941-6	Relay Switch 30/40AMP	**				
Battery Assembly				<p>* Used on GHS Models with 10.0 Bushel Catcher only. When Optional GHS 7.0 Bushel Catcher is purchased, this part is replaced by P/N 7944 (7.0 Catcher Wire Harness).</p> <p>** Service Part Only</p>			
21	6923	Negative Battery Cable	1	NOTE: Refer to ELECTRICAL CONNECTORS , Page 64 for identification of all Electrical Wiring Service Parts.			
22	5933	Battery Terminal Insul., Red (+)	1				
23	5844	Battery Hold-Down Bar	1				
24	5839	Hook Bolt	2				
25	6392	Battery Protector Plate	1				
26	7390-1	Battery Pan	1				
27	7910	Battery (12V/340CCA/Dry)	1				
28	5932	Battery Terminal Insul., Black (-)	1				
29	7834-2	Wire Saddle (2 Wires)	1				

ELECTRICAL ASSEMBLY (MT)

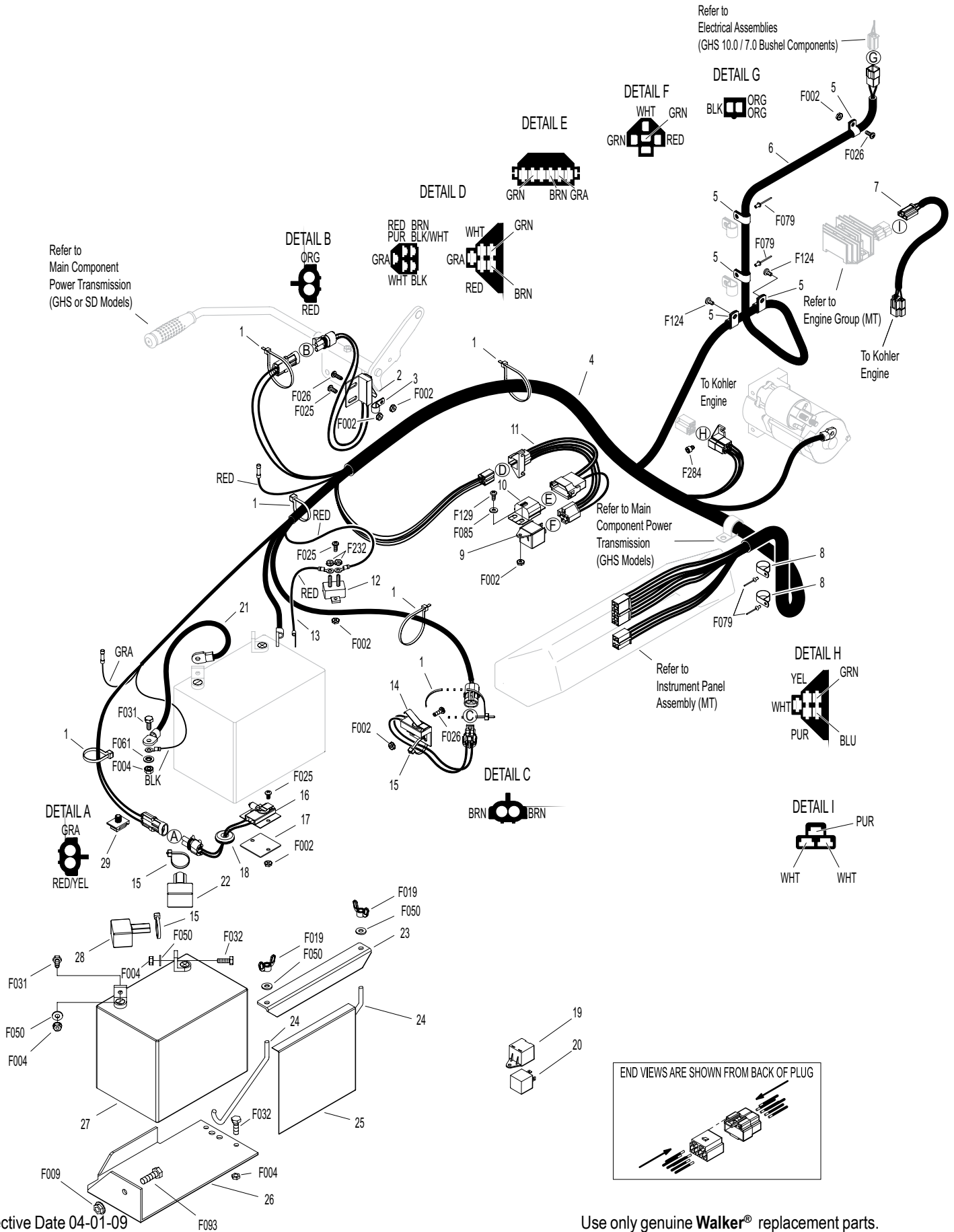

Effective Date 04-01-09

Use only genuine Walker® replacement parts.

ELECTRICAL ASSEMBLY (MTL)

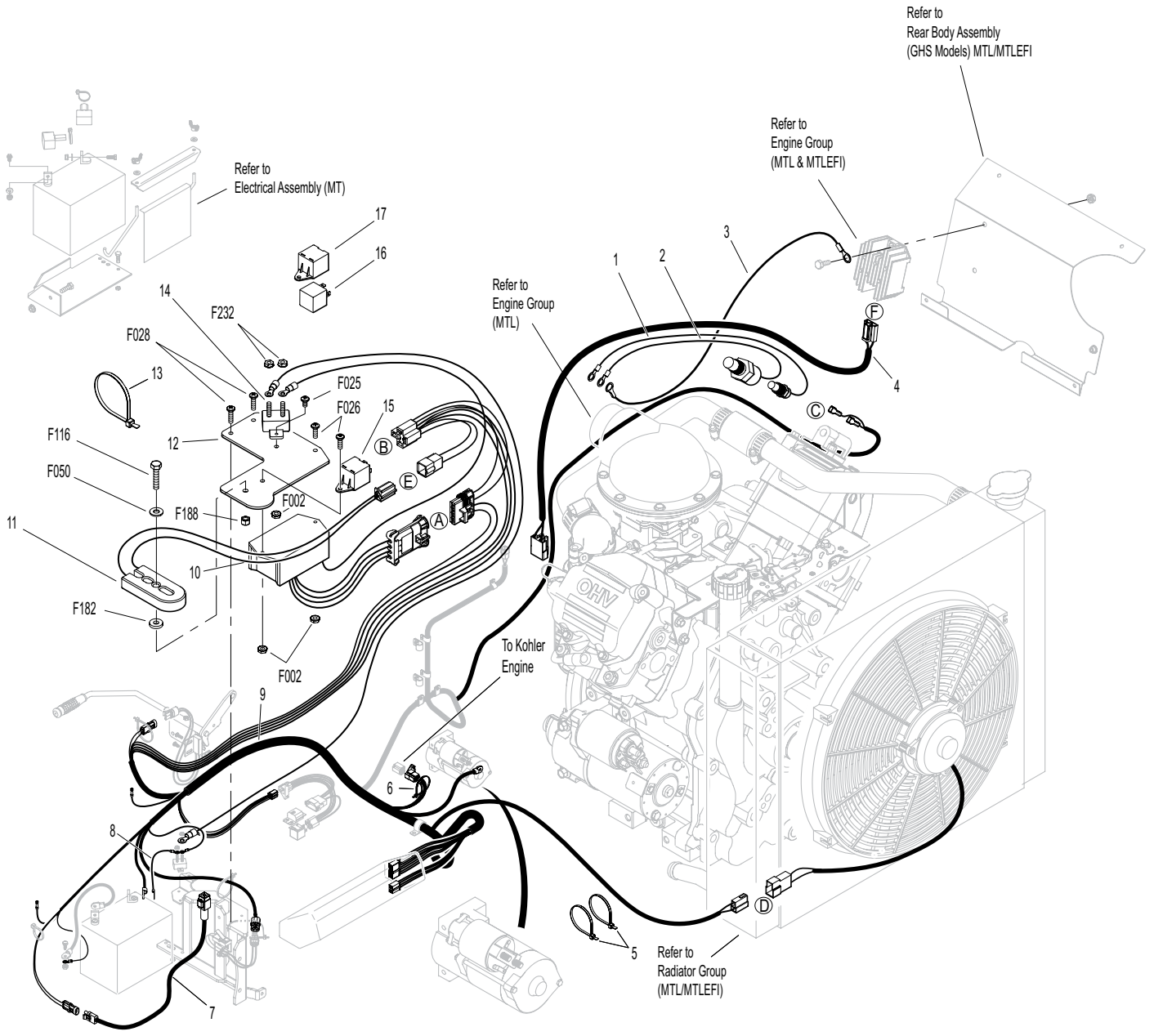

DETAIL A

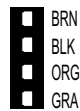

DETAIL B



DETAIL C



DETAIL D



DETAIL E



DETAIL F

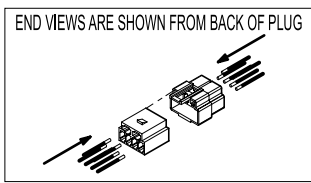
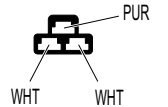

Effective Date 04-01-09

Use only genuine **Walker**® replacement parts.

ELECTRICAL ASSEMBLY (MTEFI)

ITEM NO.	PART NO.	DESCRIPTION	NO. REQ'D	ITEM NO.	PART NO.	DESCRIPTION	NO. REQ'D
Electrical Assembly				Fasteners			
1	8940-16	Wire Harness, Ext. Fuel Pump	1	F002		10-24 Keps Nut	2
2	8012-6	Regulator Adapter Harness	1	F063		3/8 Internal Star Lock Washer	1
3	5975-1	Cable Tie (18# x 3-3/4")	1	F103		10-24 x 2 PTHMS	1
4	NS	Fuse Holder (Kohler)	3	F106		3/8-16 x 5/8 Hex Bolt	1
5	6941-4	30 Amp Fuse	1	F284		M6 x 1.0 x 8 SHC Screw	1
6	NS	Relay (Kohler)	1	F361		10-24 x 2-1/2 Hex Bolt	1
7	6941-1	20 Amp Fuse	1				
8	6941-3	10 Amp Fuse	1				
9	NS	ECU Harness Clip	1				
10	NS	ECU (Kohler)	1				
11	5975-8	Cable Tie (50# x 17-1/2")	1				

NOTE: Refer to **ELECTRICAL CONNECTORS**, Page 64 for identification of all Electrical Wiring Service Parts.

ELECTRICAL ASSEMBLY (MTEFI)

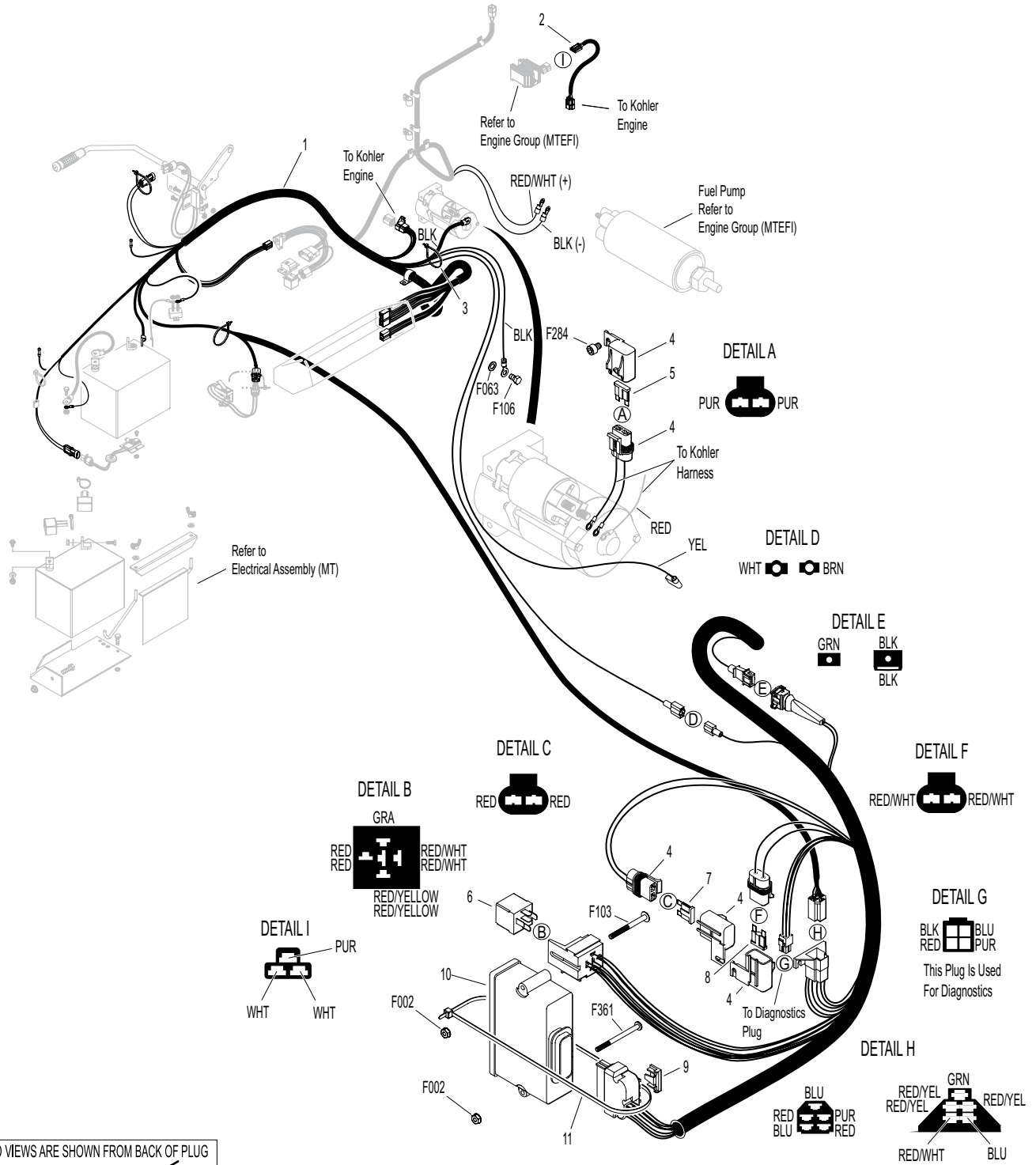

Effective Date 04-01-09

Use only genuine **Walker®** replacement parts.

ELECTRICAL ASSEMBLY (MTLEFI)

ITEM NO.	PART NO.	DESCRIPTION	NO. REQ'D	ITEM NO.	PART NO.	DESCRIPTION	NO. REQ'D
Electrical Assembly				Fasteners			
1	7306-11	Switch (205 Deg., 3/8-18 NPT)	1	F002		10-24 Keps Nut	7
2	8012-7	Ground Wire	1	F025		10-24 x 3/8 PPHMS	3
3	8012-6	Regulator Adapter Harness	1	F026		10-24 x 1/2 PPHMS	2
4	5975-1	Cable Tie (18# x 3-3/4")	4	F028		10-24 x 3/4 PPHMS	2
5	NS	Fuse Holder (Kohler)	3	F050		1/4 SAE Washer	1
6	6941-4	30 Amp Fuse	1	F063		3/8 Internal Star Lock Washer	1
7	NS	ECU Harness Clip	1	F102		10-24 x 1-1/2 PTHMS	2
8	NS	Relay (Kohler)	1	F103		10-24 x 2 PTHMS	1
9	6941-1	20 Amp Fuse	1	F106		3/8-16 x 5/8 Hex Bolt	1
10	6941-3	10 Amp Fuse	1	F116		1/4-20 x 1-1/4 Hex Bolt	1
11	8940-7	ECU Mount Plate	1	F182		1/4 x 5/8 x 1/8 Washer	1
12	NS	ECU (Kohler)	1	F188		1/4-20 Self-Locking Nut	1
13	6103-19	Adapter Harness	1	F195		1/4-20 x 3/4 PPHMS, SS	1
14	7943	Battery Cable (+)	1	F232		10-32 Keps Nut	4
15	8940-9	Wiring Harness	1	F284		M6 x 1.0 x 8 SHC Screw	1
16	7428-2	Fan Control Module W/P Plug	1				
17	7433	Resistor, Ceramic / .4 OHM	1				
18	8531-3	Reversing Module Mount	1				
19	5975-7	Cable Tie (50# x 11")	1				
20	7941	Circuit Breaker 40 Amp (Auto Reset/Sealed)	1				
21	6942	Relay Switch (30/40 Amp) NC (Includes Items # 22 & 23)	1				
22	6941-6	Relay Switch 30/40AMP	*				
23	6941-7	Relay Mount	*				

* Service Part Only

NOTE: Refer to **ELECTRICAL CONNECTORS**, Page 64 for identification of all Electrical Wiring Service Parts.

ELECTRICAL ASSEMBLY (MTLEFI)

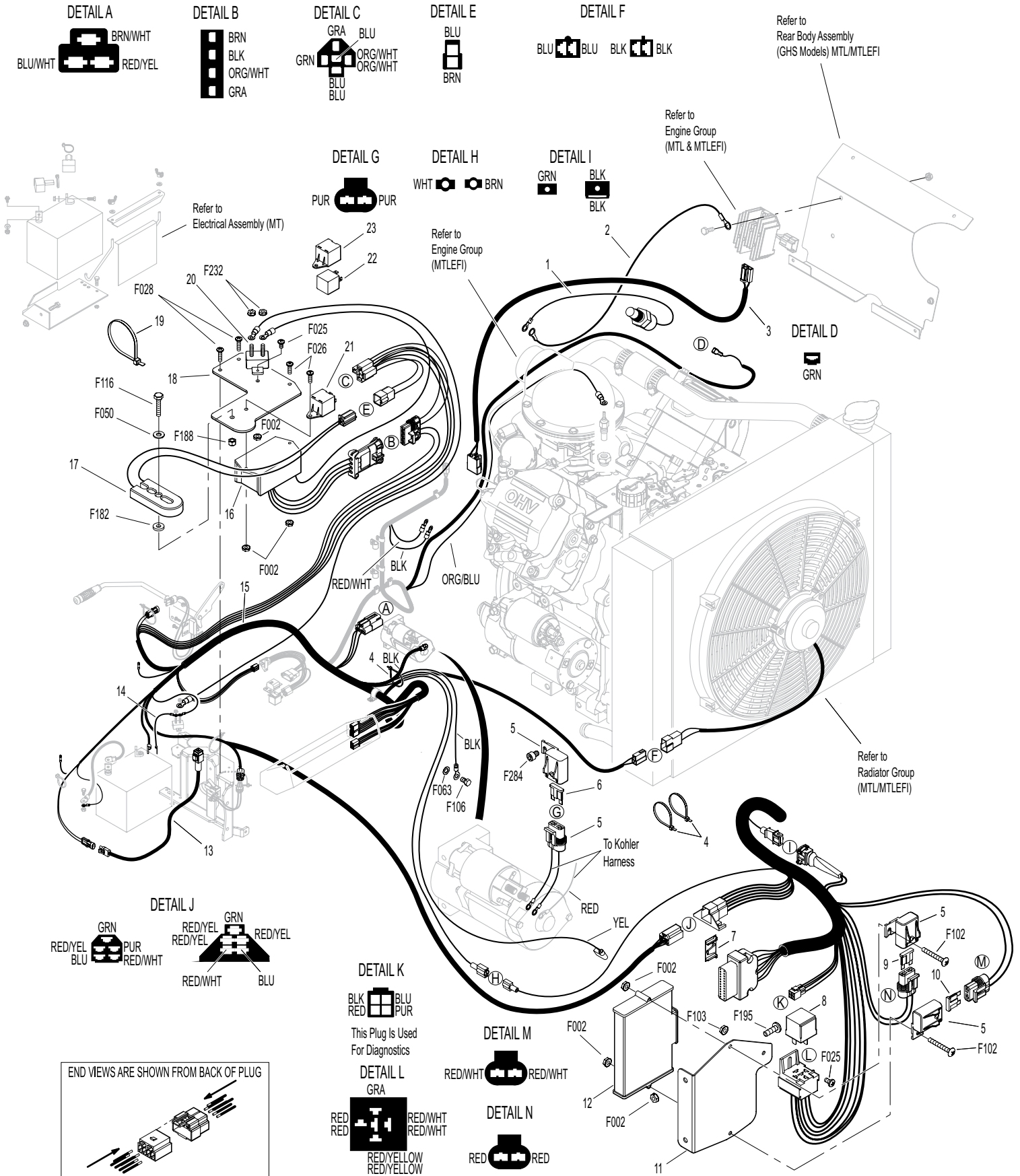

Effective Date 04-01-09

Use only genuine **Walker®** replacement parts.

ELECTRICAL ASSEMBLIES (GHS 10.0 / 7.0 BUSHEL COMPONENTS)

ITEM NO.	PART NO.	DESCRIPTION	NO. REQ'D
----------	----------	-------------	-----------

10.0 Harness Components

1	8950-3	Powerfil® Ground Wire, 10.0	1
2	8950-2	Powerfil® Power Wire, 10.0	1
3	7835	Frame Clip (3/16)	6
4	5975-3	Cable Tie (50# x 7")	2
5	5536-2	Horn, Full Signal	*
6	8950	9.5/10.0 Wire Harness	1
7	5977-2	Grommet, Cut (1/8 x 3/8)	1

7.0 Harness Components

3	7835	Frame Clip (3/16)	6
4	5975-3	Cable Tie (50# x 7")	2
5	5536-2	Horn, Full Signal	*
7	5977-2	Grommet, Cut (1/8 x 3/8)	1
8	7944	7.0 Wire Harness	1

Grass-Pak® Switch Assemblies**

9	5833	Cable Clamp (1/4)	2
10	5980-3	Wire, Grass-Pak® Switch	1
11	5592-11	Liquid Tight Plug	1
12	5592-10	Grass-Pak® Switch Module	1
	5592-4	Grass-Pak® Switch Assembly (Includes Items # 10-13, F144 & F145)	*
13	5594-5	Vane Assembly, Grass-Pak® Switch (Includes Items # F144 & F145)	1

ITEM NO.	PART NO.	DESCRIPTION	NO. REQ'D
----------	----------	-------------	-----------

Fasteners

F002	10-24 Keps Nut	5
F025	10-24 x 3/8 PPHMS	1
F037	10-24 x 5/8 PTH Screw	2
F129	10-24 x 1/2 PTHMS	2
F144	4-40 x 1/4 PPHMS	1
F145	4-40 Keps Nut	1

* Service Part Only

** Item used on 10.0 and 7.0 models

NOTE: Refer to **ELECTRICAL CONNECTORS**, Page 64 for identification of all Electrical Wiring Service Parts.

ELECTRICAL ASSEMBLIES (GHS 10.0 / 7.0 BUSHEL COMPONENTS)

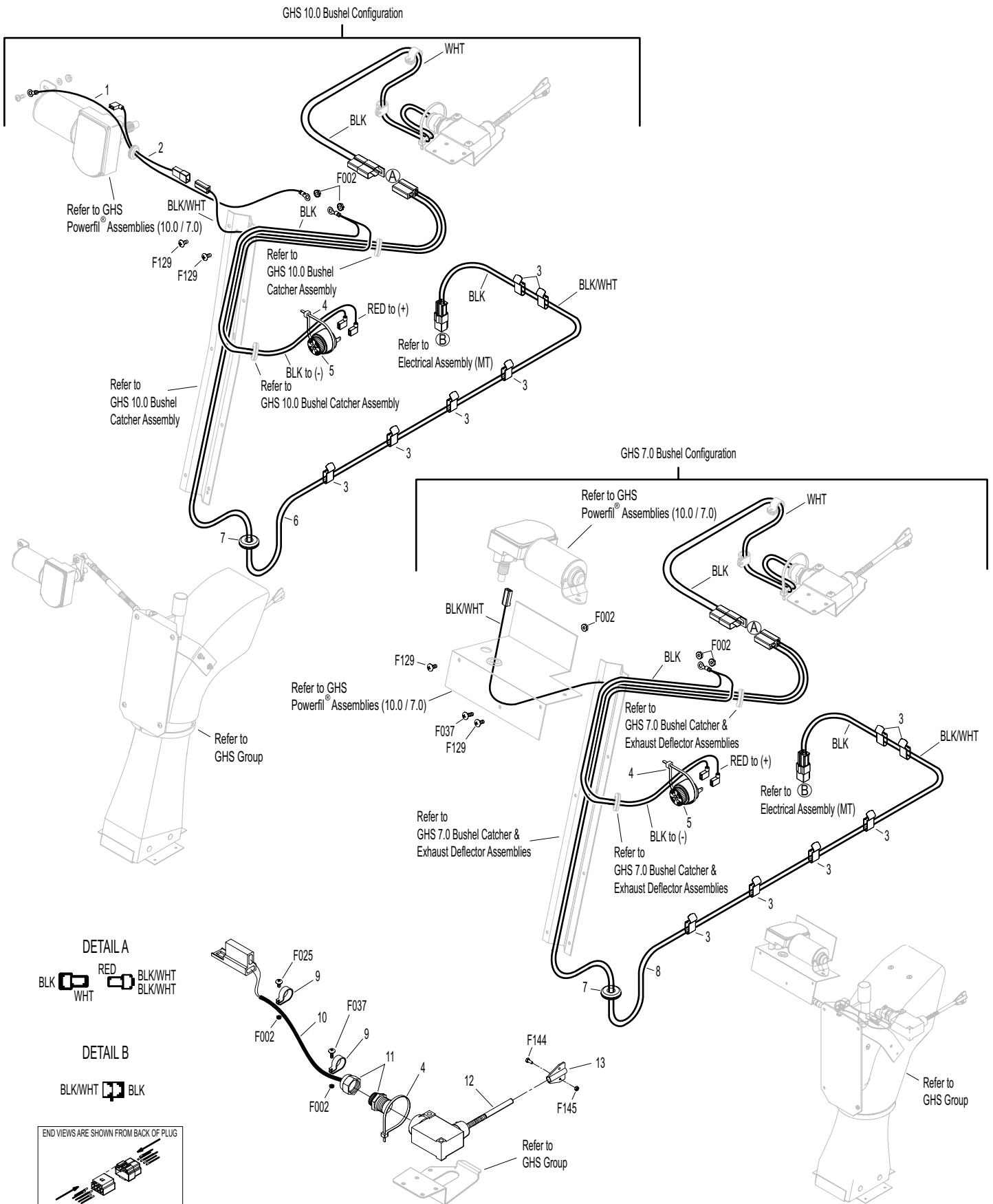

Effective Date 04-01-09

Use only genuine **Walker®** replacement parts.

ELECTRICAL CONNECTORS

ITEM NO.	PART NO.	DESCRIPTION	NO. REQ'D	ITEM NO.	PART NO.	DESCRIPTION	NO. REQ'D
Electrical Wiring Service Parts				29	7942-1	2-Way Locking Connector, Female	*
1	5996-1	16-14 GA Butt Connector	*	30	7942-2	2-Way Connector, Male	*
2	5996-11	12-10 GA Butt Connector	*	31	7942-3	2-Way Connector, Female	*
3	7942-14	16-14 GA Shrink Connector	*	32	7942-10	2-Way Locking Connector, Male	*
4	7942-13	12-10 GA Shrink Connector	*	33	5940-8	3-Way Connector, Male	*
5	5995-1	Wire Terminal Adapter	*	34	7942-9	3-Way Connector, Male	*
6	5996-4	16-14 GA Bullet Conn., Male	*	35	8944	3-Way Locking Connector, Male	*
7	5996-5	16-14 GA Bullet Conn., Female	*	36	8944-1	3-Way Locking Connector, Female	*
8	5940-4	16-14 GA Spg. Loaded Term., Female	*	37	7942-11	4-Way Connector, Male	*
9	5940-7	Wire Clip, Female	*	38	7942-12	4-Way Connector, Female	*
10	5996	1/4 x 16-14 GA QKS Term., Female	*	39	7942-5	5-Way Connector, Male	*
11	5996-2	3/16 x 22-18 GA QKS Term., Female	*	40	5940-2	5-Way Connector, Male	*
12	7996	16-14 GA QKS Term., Female	*	41	8942-1	5-Way Connector, Female	*
13	5940-5	16-14 GA Spg. Loaded Term., Male	*	42	7942-6	6-Way Connector, Male	*
14	5996-0	1/4 x 22-18 GA QKS Term., Male	*	43	7942-7	6-Way Connector, Male	*
15	5996-18	16-14 GA Ring Term. (#8) Nylon Insulated	*	44	7942-8	8-Way Connector, Male	*
16	7996-1	1/4 x 16-14 GA QKS Term., Male	*	45	8942-2	8-Way Connector, Female	*
17	5996-8	6 GA Ring Lug (5/16)	*	46	8942-3	5-Way Connector, Male	*
18	5996-9	22-18 GA Ring Term., #10	*	47	5940-9	3-Way Connector (M)	*
19	5996-10	16-14 GA Ring Term. (5/16)	*	48	7942-15	6-Way Connector (Female)	*
20	5996-12	12-10 GA Ring Term. (5/16)	*	49	7940-3	Packard Plug (Male)	*
21	5996-13	16-14 GA Ring Term., # 10	*	50	7940-4	Packard Plug (Female)	*
22	5996-15	12-10 GA Ring Term. (1/2)	*	* Service Part Only			
23	5996-16	6 GA Ring Terminal (1/4)	*	NOTE: Not all Electrical Connectors are used with all assemblies.			
24	5996-17	16-14 GA Ring Term. (1/4)	*	NOTE: Refer to ELECTRICAL ASSEMBLY , Page 54 for locations of Wiring Harness and of all Electrical Wiring Service Parts.			
25	5996-20	12-10 GA Ring Term. (1/4)	*				
26	5996-21	12-10 GA Ring Term., #10	*				
27	7942-4	Single Connector, Male	*				
28	8942	2-Way Connector, Male	*				

ELECTRICAL CONNECTORS

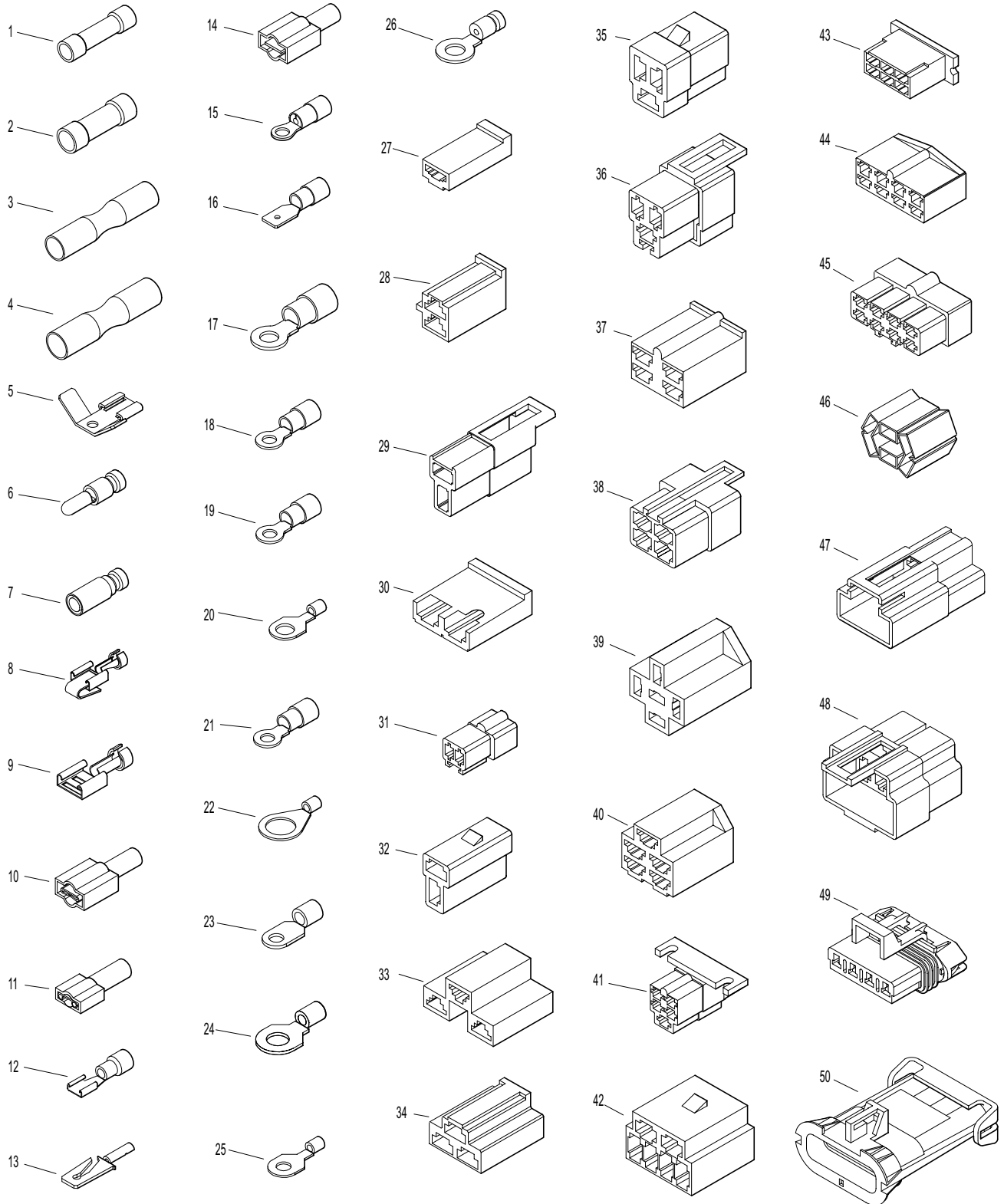

POWER DECK LIFT KIT

ITEM NO.	PART NO.	DESCRIPTION	NO. REQ'D	ITEM NO.	PART NO.	DESCRIPTION	NO. REQ'D
Kit 8655 Power Deck Lift Option / Kit Includes Items # 1-31, fasteners listed and instructions. May be ordered as a dealer-installed option. Contact your Walker dealer.				Fasteners			
1	8628	Linear Actuator (10" OAL) (Includes Items # 29, 30 & F320)	1	F002		10-24 Keps Nut	1
2	8655-8	Clamp Bar	1	F004		1/4-20 Keps Nut	11
3	7503-10	Actuator Drive Bushing	1	F009		5/16-18 Whiz Locknut	6
4	8655-10	Bushing (5/8 x 5/16 x 1-1/16)	1	F025		10-24 x 3/8 PPHMS	1
5	8655-11	Bushing (5/8 x 5/16 x 1-1/16)	1	F029		1/4-20 x 1/2 Hex Bolt	8
6	8655-7	Arm, Deck Lift	1	F032		1/4-20 x 3/4 Hex Bolt	1
7	8655-12	Bushing (3/4 x 1/4 ID x 3/4)	1	F050		1/4 SAE Washer	1
8	5977-1	Grommet (1/8 x 3/8)	1	F061		1/4 Star Lock Washer	1
9	8649	Wire Harness	1	F068		1/8 x 1 Cotter Pin	1
10	5975-5	Wire Clip, Self Mount	1	F069		3/32 x 1/2 Cotter Pin	2
11	5996-20	12-10 GA Ring Terminal (1/4)	*	F093		5/16-18 x 1 Hex Bolt	2
12	5940-4	16-14 GA Spring-Loaded Terminal (F)	*	F134		AN960816L Washer	1
13	8942-3	5-Way Connector (M)	1	F179		1/4-20 x 1 Hex Bolt	1
14	6623	Toggle Switch	1	F316		5/16-18 x 1-3/4 Hex Bolt	2
15	5996-21	12-10 GA Ring Terminal (# 10)	*	F320		1/8 x 3/4 Split Spring Pin	*
16	8655-5	Cable Mount	2	* Service Part Only			
17	8655-1	Hitch Pin/Cotterless (5/8)	2	NOTE: Power Deck Lift is not compatible with Comfort Seat or Suspension Seat.			
18	8655-6	Lift Chain	2				
19	8655-3	Cable, LH (48")	1				
20	8654	Decal, Deck Lift	1				
21	6623-1	Switch Boot	1				
22	8655-2	Cable, RH (38.5")	1				
23	6832	Cable Clamp (9/16 x 1/4)	1				
24	5832	Cable Clamp (1/2)	1				
25	8655-9	Cable Pull	1				
26	8655-22	Base, Deck Lift	1				
27	8655-4	Clevis Pin (5/16 x 3/4)	2				
28	5975-3	Cable Tie (#50 x 7")	3				
29	7942-1	2-Way Locking Connector (F)	*				
30	5940-5	16-14 GA Spring-Loaded Terminal (M)	*				
31	7942-10	2-Way Locking Connector (M)	*				

POWER DECK LIFT KIT

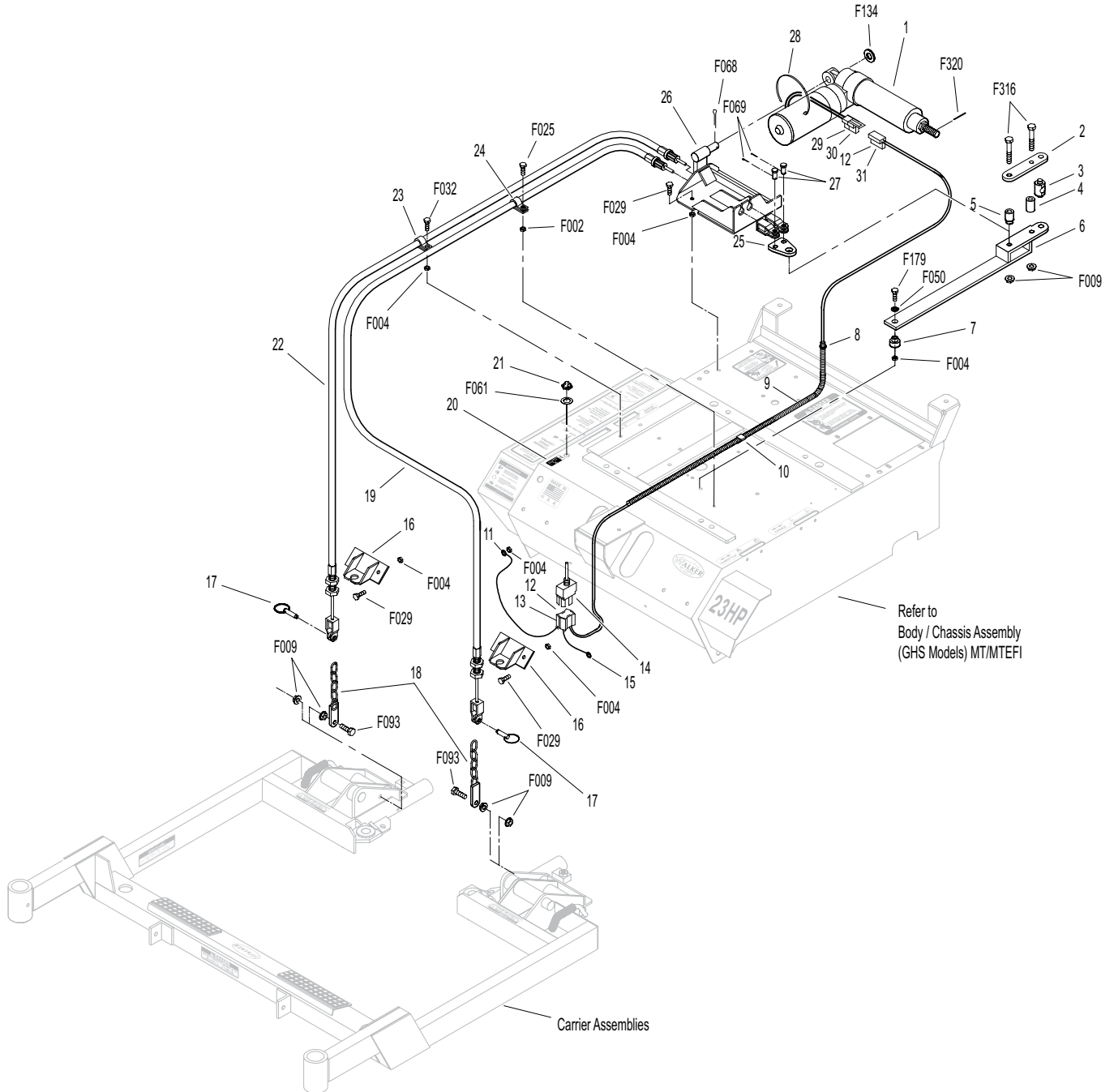

ARMREST KIT / TOUCH-UP PAINT / COMFORT SEAT KIT

ITEM NO.	PART NO.	DESCRIPTION	NO. REQ'D
----------	----------	-------------	-----------

Kit 5885 Armrest Option / Kit

Includes Items # 1-5, fasteners listed and instructions. May be ordered as a dealer-installed option. Contact your Walker dealer.

1	5886-1	Armrest, RH	1
2	5886-6	Cover Plate, RH	1
3	5887	Mounting Bracket	1
4	5886-5	Cover Plate, LH	1
5	5886-2	Armrest, LH	1
	5888	Armrest Hardware Kit (Includes Items # F305, F306, F307 & F308)	*

Touch-Up Paint

6	5866	Touch-Up Paint, Yellow (12 oz. Aerosol)	
7	5867	Touch-Up Paint, Grey (12 oz. Aerosol)	

Kit 6103-5 Comfort Seat Kit (Cordura)

Includes Items # 8, 13, fasteners listed and instructions. May be ordered as a dealer-installed option. Contact your Walker dealer.

8	6103-5	Comfort Seat	1
9	7203	Seat Spring Plate	**
10	7223-1	Compression Spring	**
11	7846	Rubber Washer (3/8 x 1-1/4 x 1/8)	**
12	7204	Shoulder Bolt, Seat Mount	**
13	7203-6	Riser Plate, Seat Switch	***
14	7845	Rubber Bumper (1.375 x .63)	**
15	7440-5	Shock Mount (1-1/4 x 3/4)	**

ITEM NO.	PART NO.	DESCRIPTION	NO. REQ'D
----------	----------	-------------	-----------

Kit 6103-17 Armrest Option / Kit

Includes Items # 16, 17 and instructions. Item # 16 is the **Right** side armrest only. Item # 17 is the **Left** side armrest only. Sold only as a complete set and may be ordered together as a factory-installed option or as a kit for dealer installation. Contact your Walker dealer.

16	6103-42	Armrest, RH/Cordura	1
17	6103-41	Armrest, LH/Cordura	1

Fasteners

F009	5/16-18 Whiz Locknut	**
F026	10-24 x 1/2 PPHMS	2
F227	3/8 x 1-1/4 x 1/8 Plastic Washer	**
F305	1/4-20 x 3/8 SH Cap Screw	2
F306	3/8-16 x 3/4 Hex Bolt	4
F307	#10 x 5/8 PPHST Screw	2
F308	1-1/4 x 1-5/8 Wave Spring Washer	2

* Service Part Only

** Reuse existing parts from Seat Assembly. Refer to **BODY / CHASSIS ASSEMBLY (GHS MODELS) MT/MTEFI**, Page 4.

*** Only one Riser Plate is included with kit. One is reused from Seat Assembly. Refer to **BODY / CHASSIS ASSEMBLY (GHS MODELS) MT/MTEFI**, Page 4.

ARMREST KIT / TOUCH-UP PAINT / COMFORT SEAT KIT

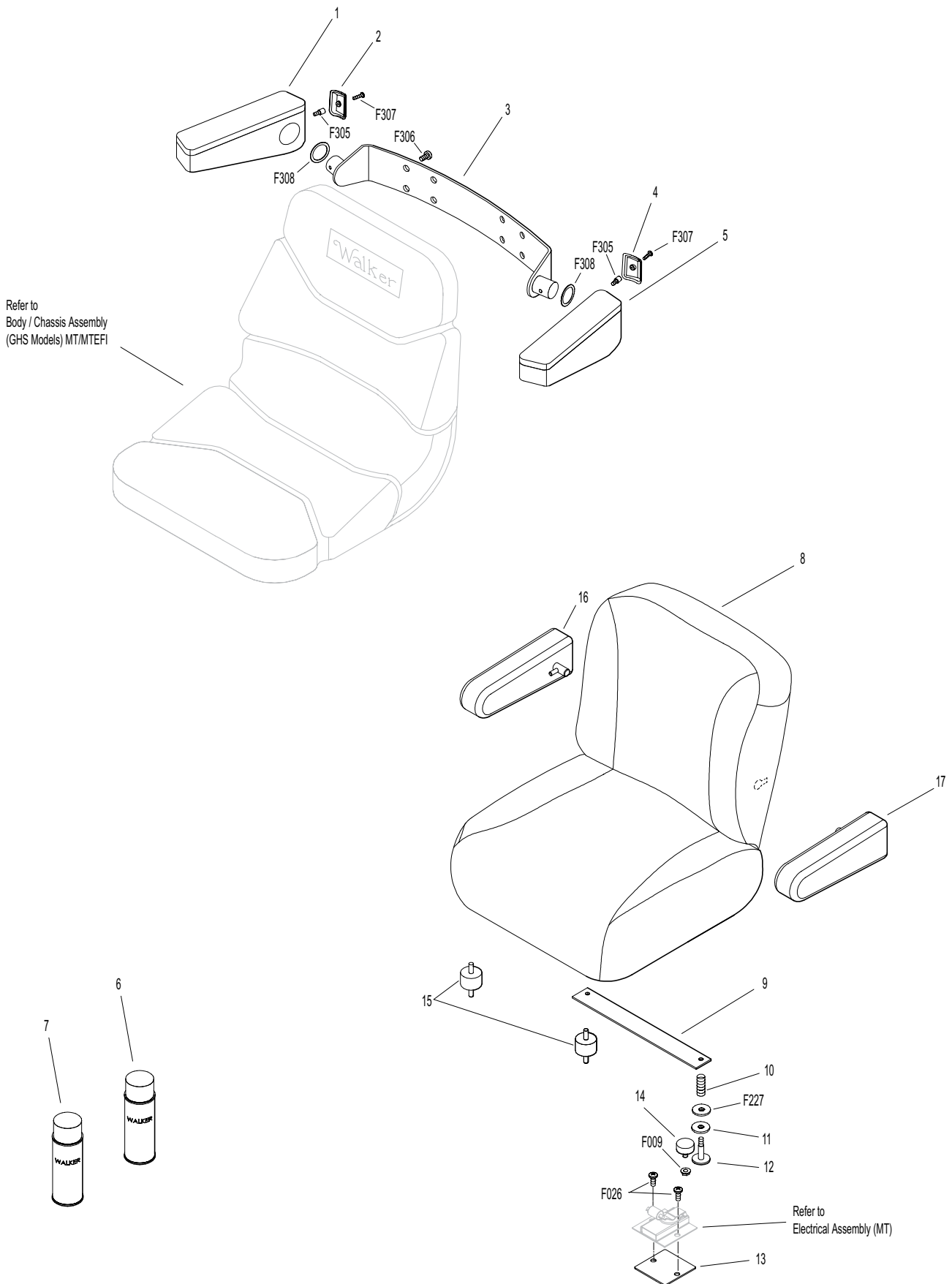

Effective Date 04-01-09

Use only genuine **Walker**® replacement parts.

SUSPENSION SEAT KIT

ITEM NO.	PART NO.	DESCRIPTION	NO. REQ'D
----------	----------	-------------	-----------

Kit 6103-24 Suspension Seat Option / Kit

Includes Items # 1-9, fasteners listed and instructions. May be ordered as a factory-installed option or as a kit for dealer installation. Contact your Walker dealer.

1	6103-14	Suspension Seat	1
2	6103-35	Suspension Seat Mount	2
3	7440-7	Shock Mount	4
4	6105-1	Shoulder Washer	2
5	6103-19	Adapter Harness	1*
6	6105-3	Harness Clip	2
7	5977-3	Grommet (9/16)	1
8	5453-20	Steering Lever Handle +1" Adj. / SS	2
9	7833-2	Cable Clamp (1 x 1/4)	1

Suspension Seat Replacement Parts**

10	6105-5	Back Cushion/Vinyl	1
11	6105-7	Left Hand Armrest	1
12	6105-10	Handle	1
13	6105-6	Right Hand Armrest	1
14	6105-8	Grammer Seat Switch	***
15	6105-9	Wear Part Kit	***

ITEM NO.	PART NO.	DESCRIPTION	NO. REQ'D
----------	----------	-------------	-----------

Fasteners

F002	10-24	Keps Nut	1
F009	5/16-18	Whiz Locknut	8
F025	10-24 x 3/8	PPHMS	1
F091	5/16-18 x 5/8	Hex Bolt	4
F188	1/4-20	Self-Locking Nut	4
F198	.250 x .625 x .040	Washer, SS	2
F345	1/4-20 x .770	Knurled Bolt	4
F429	5/16-18 x 1/2	SFH Screw	4

* Remove existing Seat Switch. Plug Harness into Seat Harness.

** Installation of worn parts included in the scope of delivery of spare parts **must be performed exclusively in authorized workshops by trained or suitably qualified personnel** and in adherence with the **applicable repair manual**.

*** Replace all existing old parts with enclosed new ones. If there is no new part included, the old one is to be cleaned and checked for its suitability for re-use. Defective parts and worn parts must always be replaced by new ones.

SUSPENSION SEAT KIT

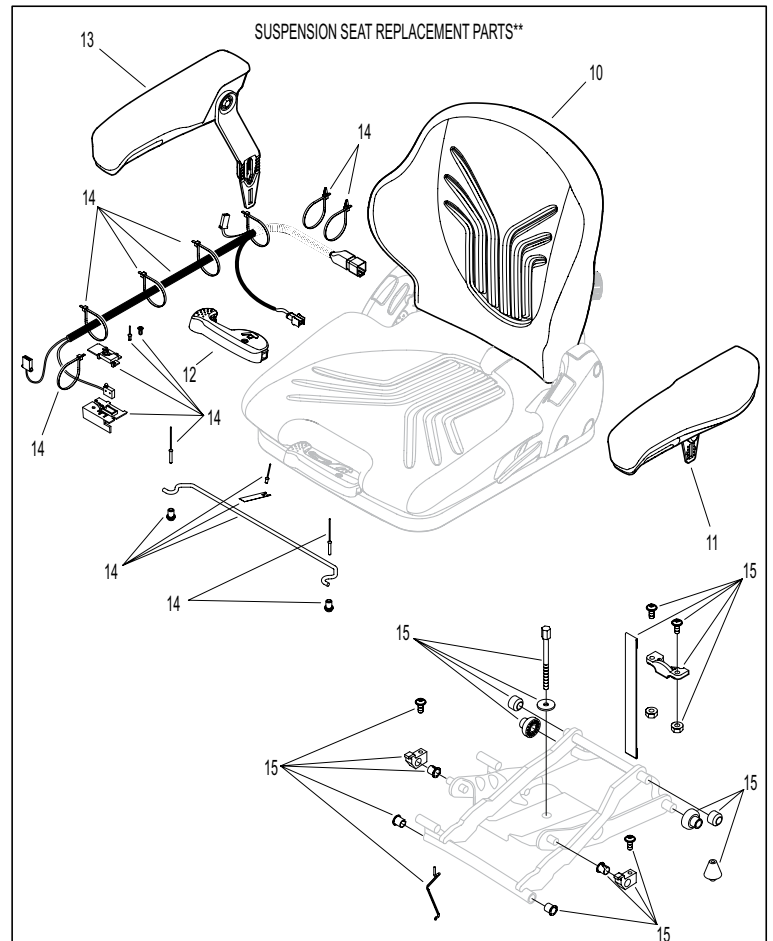
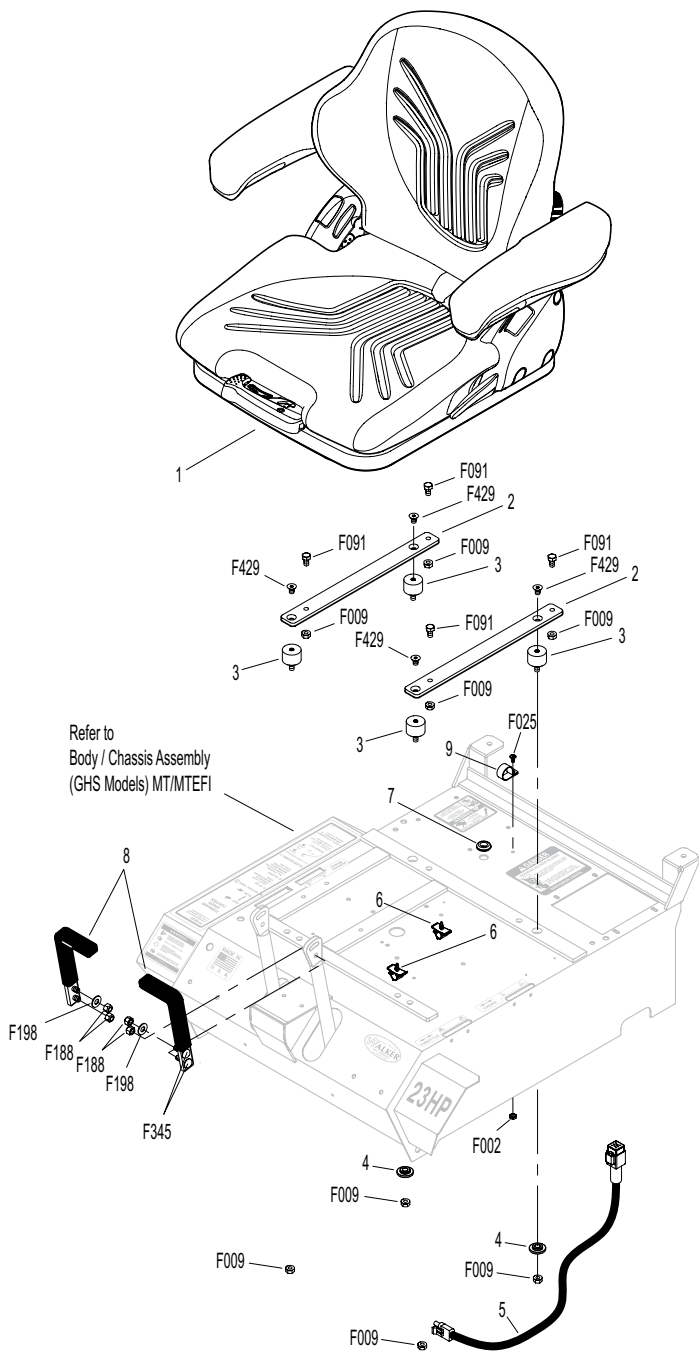

Effective Date 04-01-09

Use only genuine **Walker®** replacement parts.

LIGHT KIT / COLD START KIT / SPEED UP KIT

ITEM NO.	PART NO.	DESCRIPTION	NO. REQ'D
----------	----------	-------------	-----------

Kit 7989-11 Light Option / Kit

Includes Items # 1-10, fasteners listed and instructions. May be ordered as a dealer-installed option. Contact your Walker dealer.

1	7989-2	Light Assembly (Halogen) (Includes Items # 2 & 4) (Includes Halogen Bulb)	2
	7989-6	Bulb Replacement (Halogen)	*
2	7989-3	Wire Harness Extension	2
3	7834-2	Wire Saddle (2 Wires)	8
4	5996-4	16-14 GA Bullet Cntr. (M)	3
5	5996-5	16-14 GA Bullet Cntr. (F)	2
6	7993-1	Mount Bracket, Lights	1
7	7995-3	Power Lead Wire Assembly (Includes Items # 4, 5, 8, 9 & 10)	1
8	5977-1	Grommet (1/8 x 3/8)	2
9	5975-1	Cable Tie (18# x 3-3/4")	1
10	5996	1/4 x 16-14 GA QDF Terminal	1

Kit 8638 Cold Start Option / Kit

Includes Items # 11-13, fasteners F004, F029 and instructions.

11	5830	Grease Fitting	1
12	7406-1	Handle Grip, Red	1
13	8638-1	Idler Release (Includes Items # 11 & 12)	1

ITEM NO.	PART NO.	DESCRIPTION	NO. REQ'D
----------	----------	-------------	-----------

Kit 8247 Speed-Up Option / Kit

Includes Items # 14, 15 and instructions.

14	5224	Extension Spring (1 x 4)	1
15	7240-1	Jackshaft Drive Pulley (3-1/2/3V) (Includes Items # F067 & F171)	1

Both kits may be ordered as a dealer-installed option. Contact your Walker dealer.

Fasteners

F004	1/4-20 Keps Nut	2
F009	5/16-18 Whiz Locknut	2
F029	1/4-20 x 1/2 Hex Bolt	2
F052	5/16 Ext. Star Lock Washer	2
F067	3/16 x 3/16 x 1 Key	1
F091	5/16-18 x 5/8 Hex Bolt	2
F171	5/16-18 x 3/8 Set Screw	*

* Service Part Only

NOTE: Upon installation of kit, Item # 8 replaces P/N 5989-4 (Dome Plug, 3/8) and Item # F091 replaces P/N 5989-3 (Dome Plug, 5/16). Dome Plugs are not shown here. Refer to **BODY / CHASSIS ASSEMBLY (GHS MODELS) MT/MTEFI**, Page 4.

NOTE: Refer to **ELECTRICAL CONNECTORS**, Page 64 for identification of all Electrical Wiring Service Parts.

LIGHT KIT / COLD START KIT / SPEED UP KIT

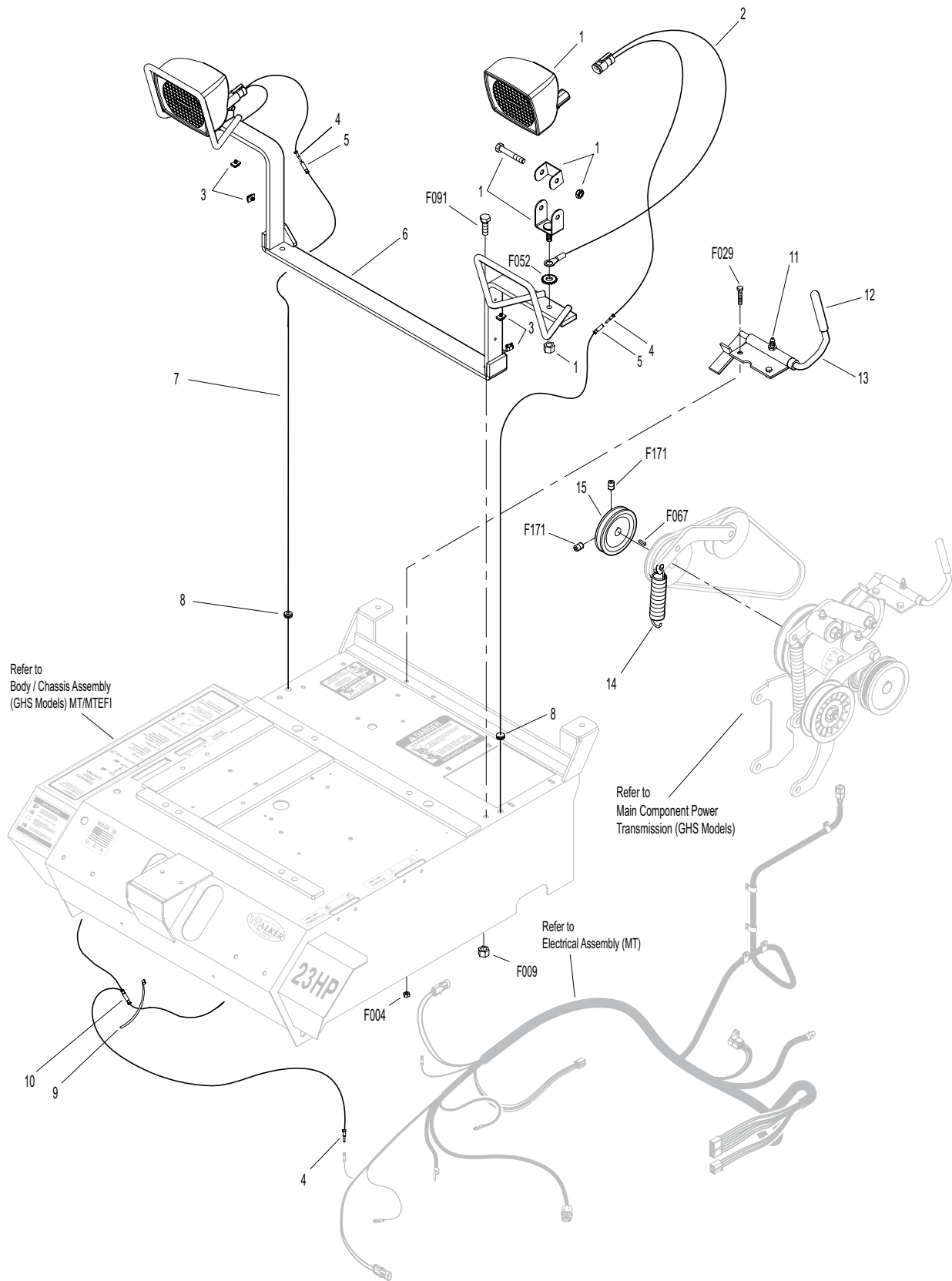

POWER DUMP KIT (10.0 BUSHEL GHS MODELS ONLY)

ITEM NO.	PART NO.	DESCRIPTION	NO. REQ'D	ITEM NO.	PART NO.	DESCRIPTION	NO. REQ'D
Kit 8620-2 Power Dump Option / Kit (10.0 Models Only) Includes Items # 1-35, fasteners listed and instructions. May be ordered as a factory-installed option or as a kit for dealer installation. Contact your Walker dealer.				Fasteners			
1	5103-7	Outside Torsion Bushing	2	F002		10-24 Keps Nut	4
2	7620-3	Pivot Bushing (1/2 x 9/16)	6	F003		1/4-28 Hex Nut	2
3	8623-5	Torsion Spring Hook	2	F004		1/4-20 Keps Nut	4
4	5221-2	Extension Spring (3/4 x 3-1/2")	2	F009		5/16-18 Whiz Locknut	6
5	8608-9	Torsion Bar	1	F012		3/8-16 Keps Nut	2
6	8623-3	Extension Spring Cable	2	F020		5/16-18 ESNA Nut	2
7	5214-12	Ball Joint (5/16-24)	2	F024		5/16-24 Jam Nut	2
8	8607-10	Lower Arm/Power Dump	2	F028		10-24 x 3/4 PPHMS	4
9	7523-2	Clevis Pin W/Hole (1/4 x 5/8)	4	F029		1/4-20 x 1/2 Hex Bolt	4
10	8623-7	Inner Power Dump Arm, LH	1	F039		3/8-16 x 1-1/4 Hex Bolt	2
11	8623-6	Inner Power Dump Arm, RH	1	F049		5/16 SAE Washer	4
12	7620-6	Cable Guide	2	F068		1/8 x 1 Cotter Pin	4
13	8105-4	Rear Body Panel, RH (MT/MTEFI)	1	F069		3/32 x 1/2 Cotter Pin	8
	8105-6	Rear Body Panel, RH (MTL/MTLEFI)	1	F085		3/16 Rivet Backup Washer	4
14	8105-3	Rear Body Panel, LH (MT/EFI)	1	F093		5/16-18 x 1 Hex Bolt	1
	8105-35	Rear Body Panel, LH (MTL)	1	F134		AN960816L Washer	4
15	8620-5	Guard, 10.0 Power Dump Motor	1	F266		1/2 x 2-3/4 Shoulder Bolt	1
16	8623-2	Power Dump Cable, 10.0	2	F287		1/4-28 Keps Nut	2
17	5975-7	Cable Tie (50# x 11")	1	F337		1/4-20 x 5/8 Self-Tap Bolt	2
18	7721	Linear Actuator (13.898)	1	F456		5/16-18 x 3/4 SBH Cap Screw, SS	2
19	5552	Ball Joint (1/4-28)	2				
20	7628-1	Channel Angle, RH	1				
21	7620-9	Roller Wheel	2				
22	7629	Channel Angle, LH	1				
23	5830	Grease Fitting	3				
24	7636-1	Actuator Mount, 10.0	1				
25	7624-1	Roller Bearing Bolt	1				
26	7627	Front Actuator Mount	1				
27	7624	Sealed Needle Bearing	1				
28	7630-3	Ram Pivot and Spacer	1				
29	7625	Fork	1				
30	5975-1	Cable Tie (18# x 3-3/4")	1				
31	5975-3	Cable Tie (50# x 7")	5				
32	7622	Wire Harness	1				
33	6623	Toggle Switch	1				
34	6623-1	Switch Boot	1				
35	7633	Decal, Power Dump	1				

NOTE: Refer to **ELECTRICAL CONNECTORS**, Page 64 for identification of all Electrical Wiring Service Parts.

POWER DUMP KIT (7.0 BUSHEL GHS MODELS ONLY)

ITEM NO.	PART NO.	DESCRIPTION	NO. REQ'D	ITEM NO.	PART NO.	DESCRIPTION	NO. REQ'D
Kit 7620-13 Power Dump Option / Kit (7.0 Models Only) Includes Items # 1-32, fasteners listed and instructions. May be ordered as a factory-installed option or as a kit for dealer installation. Contact your Walker dealer. Not to be used with optional Dump Bag Kits.				Fasteners			
1	5522-20	Hinge Backup Plate/RH/PD	1	F002		10-24 Keps Nut	6
2	7620-3	Pivot Bushing (1/2 x 9/16)	2	F003		1/4-28 Hex Nut	2
3	7612-4	Door Actuator Arm, RH	1	F004		1/4-20 Keps Nut	4
4	7612-3	Door Actuator Arm, LH	1	F009		5/16-18 Whiz Locknut	6
5	5522-10	Hinge Backup Plate/LH/PD	1	F012		3/8-16 Keps Nut	2
6	7610-5	Extension Spring (1/4 x 2-7/8)	1	F028		10-24 x 3/4 PPHMS	4
7	7523-2	Clevis Pin W/Hole (1/4 x 5/8)	2	F029		1/4-20 x 1/2 Hex Bolt	4
8	7623	Power Dump Cable	2	F039		3/8-16 x 1-1/4 Hex Bolt	2
9	5975-7	Cable Tie (50# x 11")	1	F068		1/8 x 1 Cotter Pin	2
10	7621	Linear Actuator/7.0	1	F069		3/32 x 1/2 Cotter Pin	4
11	5552	Ball Joint (1/4-28)	2	F085		3/16 Rivet Backup Washer	4
12	7628-1	Channel Angle, RH	1	F093		5/16-18 x 1 Hex Bolt	1
13	7620-9	Roller Wheel	2	F128		10-24 x 3/8 PTHMS	2
14	7629	Channel Angle, LH	1	F134		AN960816L Washer	4
15	5830	Grease Fitting	3	F183		.312 x .700 x .074 Washer	2
16	7626-0	Actuator Mount	1	F266		1/2 x 2-3/4 Shoulder Bolt	1
17	7624-1	Roller Bearing Bolt	1	F267		1/2 x 1 x 1/16 Washer	4
18	7627	Front Actuator Mount	1	F287		1/4-28 Keps Nut	2
19	7624	Sealed Needle Bearing	1				
20	7630-3	Ram Pivot and Spacer	1				
21	7625	Fork	1				
22	5975-1	Cable Tie (18# x 3-3/4")	1				
23	5975-3	Cable Tie (50# x 7")	5				
24	7622	Wire Harness	1				
25	6623	Toggle Switch	1				
26	6623-1	Switch Boot	1				
27	7633	Decal, Power Dump	1				
28	8105-3	Rear Body Panel, LH (MT/EFI)	1				
	8105-35	Rear Body Panel, LH (MTL)	1				
29	8105-4	Rear Body Panel, RH (MT/MTEFI)	1				
	8105-6	Rear Body Panel, RH (MTL/MTLEFI)	1				
30	7620-12	Cable Rod Guide (7.0)	2				
31	7620-6	Cable Guide	2				
32	7613-2	Door Actuator (5/16-18)	2				

NOTE: Two F009 Fasteners are reused from the Rear Gas Spring Assembly. Refer to **REAR BODY ASSEMBLY (GHS MODELS) MT/MTEFI**, Page 8.

NOTE: Refer to **ELECTRICAL CONNECTORS**, Page 64 for identification of all Electrical Wiring Service Parts.

POWER DUMP KIT (7.0 BUSHEL GHS MODELS ONLY)

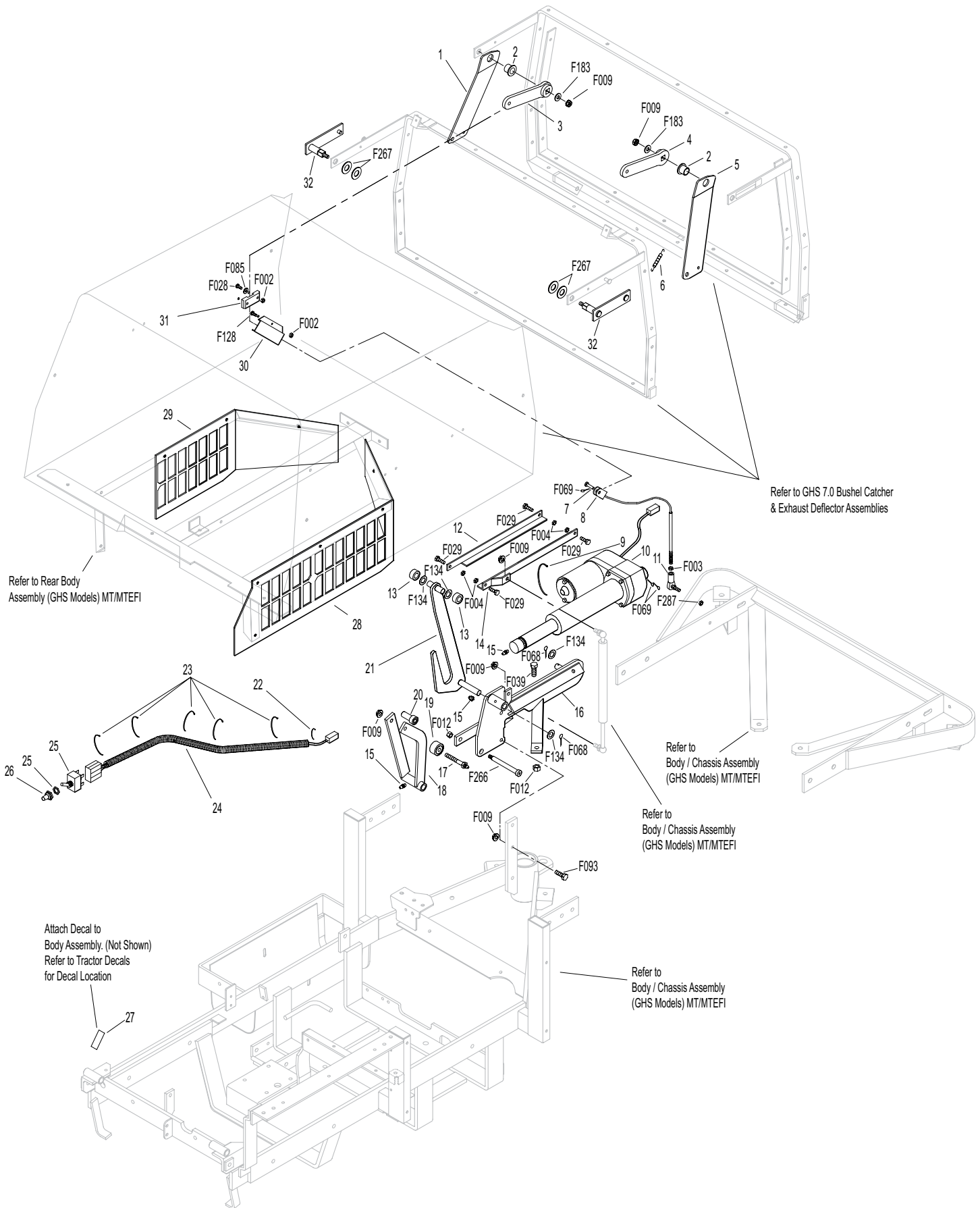

Effective Date 04-01-09

Use only genuine **Walker®** replacement parts.

HI-DUMP KIT

ITEM NO.	PART NO.	DESCRIPTION	NO. REQ'D	ITEM NO.	PART NO.	DESCRIPTION	NO. REQ'D
Hi-Dump Kit				48	8400-15	Switch Mount	1
1	5214-12	Ball Joint (5/16-24)	2	49	8400-9	Decal, Hi-Dump Operation	1
2	8607-10	Lower Arm, Power Dump	2	50	8400-14	Switch Cover (Includes Item # 49)	1
3	7620-3	Pivot Bushing (1/2 x 9/16)	6	51	8403-18	Pump Guard	1
4	5103-7	Outside Torsion Bushing	2	52	8400-1	Bumper/Hi-Dump Mount (Includes Item # 43)	1
5	7523-2	Clevis Pin W/Hole (1/4 x 5/8)	4	53	8400-2	Rear Pivot, RH (Includes Items # 27 & 36)	1
6	8623-6	Inner Power Dump Arm, RH	1	54	8402-8	Control Lift Rod	2
7	8623-3	Extension Spring Cable	2	55	5214-11	Ball Joint (1/2-20LH) Hi Strength	2
8	5221-2	Extension Spring (3/4 x 3-1/2")	2	56	7847	Rubber Bumper (1.5 OD x 1.0)	1
9	8623-5	Torsion Spring Hook	2	Fasteners			
10	8608-9	Torsion Bar	1	F002	10-24 Keps Nut	10	
11	8623-7	Inner Power Dump Arm, LH	1	F003	1/4-28 Hex Nut	2	
12	7620-6	Cable Guide	2	F004	1/4-20 Keps Nut	8	
13	8623-2	Power Dump Cable, 10.0	2	F009	5/16-18 Whiz Locknut	16	
14	5552	Ball Joint (1/4-28)	2	F012	3/8-16 Keps Nut	12	
15	7628-1	Channel Angle, RH	1	F016	1/2-13 Self-Locking Nut	2	
16	8404-4	Channel Angle/Hi-Dump, LH	1	F020	5/16-18 ESNA Nut	2	
17	7146	13mm Ball Stud	2	F024	5/16-24 Jam Nut	2	
18	8402-3	Backup Plate	1	F025	10-24 x 3/8 PPHMS	1	
19	7145	Gas Spring Assembly (Includes Items # 17 & 20)	1	F028	10-24 x 3/4 PPHMS	4	
20	7147	Spring Clip	2	F029	1/4-20 x 1/2 Hex Bolt	4	
21	5841	Retainer Washer (3/8 x 1-1/4)	4	F034	5/16-18 x 3/4 Hex Bolt	6	
22	8845	Rubber Bumper (30mm OD x 40mm) 5/16-18 Female	3	F035	5/16-18 x 1-1/4 Hex Bolt	2	
23	8404-6	Clevis Pin (1/2 x 1-1/2)	1	F037	10-24 x 5/8 PTH Screw	2	
24	8402-6	Catcher Pivot Plate, Hi-Dump	2	F038	3/8-16 x 1 Hex Bolt	4	
25	7620-9	Roller Wheel	2	F039	3/8-16 x 1-1/4 Hex Bolt	4	
26	8402-2	Catcher Pivot Arm (Includes Item # 27)	1	F040	3/8-16 x 1-1/2 Hex Bolt	3	
27	5830	Grease Fitting	5	F048	1/2 SAE Washer	1	
28	8404-5	Clevis Pin (1/2 x 1-1/4)	1	F049	5/16 SAE Washer	5	
29	8402-4	Upper Cylinder Mount Arm	1	F052	5/16 Ext. Star Lock Washer	1	
30	8402-1	Catcher Frame/Hi-Dump (Includes Items # 27 & 33)	1	F068	1/8 x 1 Cotter Pin	2	
31	7845	Rubber Bumper (1.375 x .63)	2	F069	3/32 x 1/2 Cotter Pin	4	
32	8401-4	Upper Pivot Shaft	1	F085	3/16 Rivet Backup Washer	4	
33	8201-3	Fiberglide Bearing	4	F111	1/8 x 3/4 Cotter Pin	2	
34	8401-5	Pivot Arm (Includes Item # 35)	1	F134	AN960816L Washer	2	
35	8401-9	Decal, Safety Lockout Arm	1	F151	3/8-16 x 7/8 Hex Bolt	2	
36	5683	Pivot Bearing	2	F208	5/16-18 x 2-1/4 Hex Bolt	5	
37	8401-1	Torsion Spring (1-1/2)	1	F241	.375 x .875 x .10 Washer	2	
38	8401-6	Spring Bushing	1	F287	1/4-28 Keps Nut	2	
39	8401-3	Safety Lockout Arm	1	F385	1/4 x 1-1/4 Roll Pin	1	
40	8401-2	Safety Lockout Spring	1	F395	1/4-20 x 2-1/4 FHA Screw, SS	4	
41	8400-3	Rear Pivot, LH (Includes Items # 27 & 36)	1	F396	10-24 x 1-1/4 PPH Bolt	2	
42	5214-10	Ball Joint (1/2-20) Hi Strength	2	F398	1/4-20 x 2 Hex Bolt	2*	
43	8400-8	Decal, Hi-Dump	1	F399	1/2-13 x 3-1/4 Hex Bolt	2	
44	8404-7	Adapter Bracket, MTL	1*	F405	3/8-16 x 1-1/2 FHA Screw, SS	1	
45	8430-1	Body Chute, Hi-Dump (10.5)	1	F420	5/16-18 x 1-1/4 Carriage Bolt	1	
46	8400-10	Auxiliary Power Terminal Plate (Includes Item # 47)	1	F440	1/2-20 Jam Nut RH	2	
47	8400-7	Decal, Electrical Jumper Warning	1	F441	1/2-20 Jam Nut/Left Hand	2	
				F456	5/16-18 x 3/4 SBH Cap Screw, SS	2	
				* Model MTL Only			

Use only genuine **Walker**® replacement parts.

Effective Date 04-01-09

HI-DUMP KIT

Refer to
GHS 10.0 Bushel Catcher Assembly or
GHS 7.0 Bushel Catcher & Exhaust Deflector Assemblies

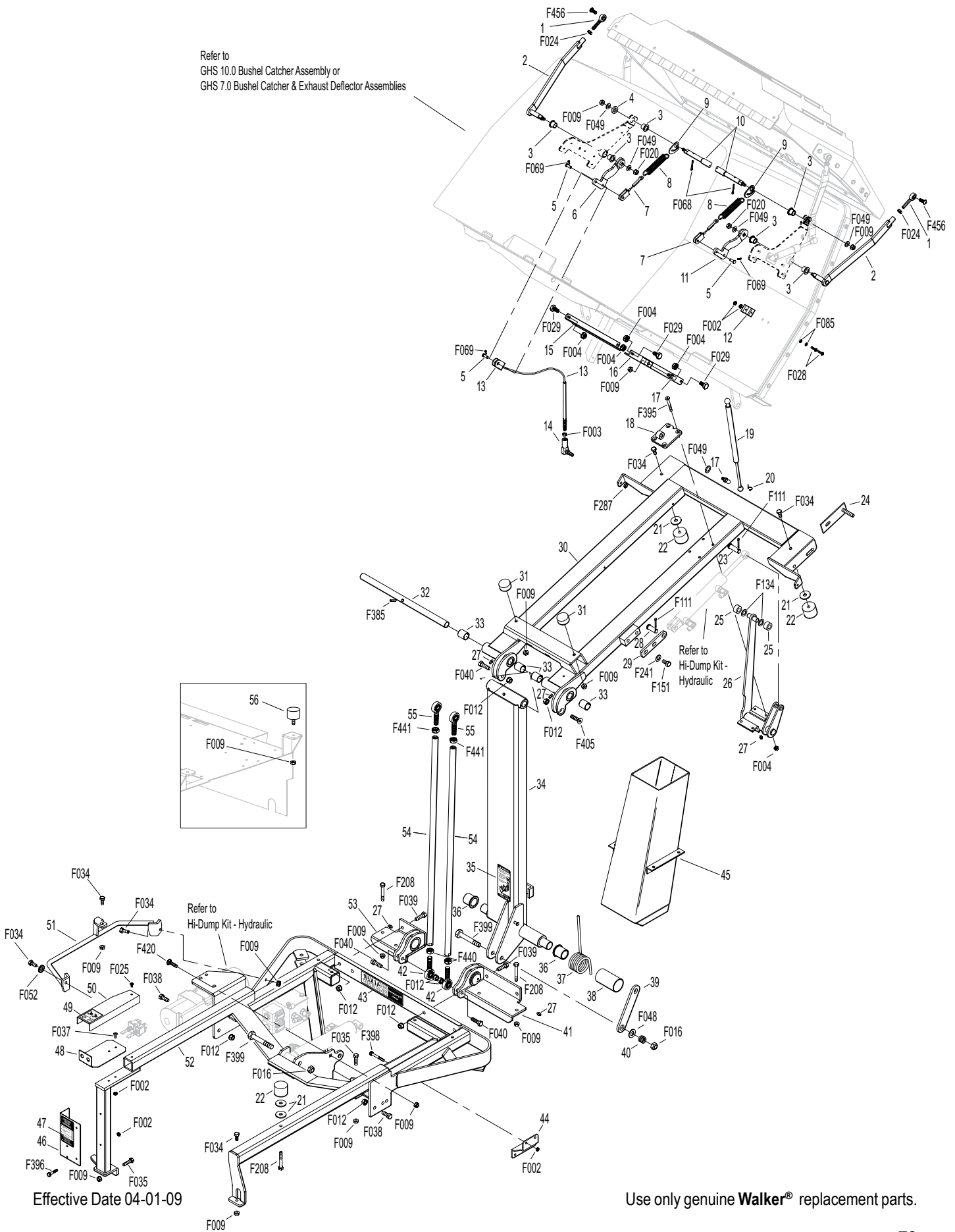

Effective Date 04-01-09

Use only genuine **Walker®** replacement parts.

HI-DUMP KIT - HYDRAULIC

ITEM NO.	PART NO.	DESCRIPTION	NO. REQ'D	ITEM NO.	PART NO.	DESCRIPTION	NO. REQ'D
Hi-Dump Kit				Component Replacement Part			
1	5833	Cable Clamp (1/4)	3	35	8403-11	Counterbalance Valve	1
2	8440-1	Catcher Adapter Harness	1	36	8403-8	Directional Valve	2
3	8404	Dump Cylinder	1	37	8403-9	Coil W/Connectors	2
4	8403-7	90° Fitting	12	38	8403-1	Reservoir / Power Unit	1
5	5975-3	Cable Tie (50# x 7")	1	Fasteners			
6	8403-5	Hydraulic Hose, Catcher Box Dump (67.5)	1	F002	10-24 Keps Nut		7
7	8403-6	Hydraulic Hose, Catcher Box Dump (73.5)	1	F004	1/4-20 Keps Nut		2
8	5835	Cable Clamp (3/4)	6	F025	10-24 x 3/8 PPHMS		11
9	8403-3	Hydraulic Hose, Lift / Rear (11.5)	1	F026	10-24 x 1/2 PPHMS		1
10	8404-1	Lift Cylinder	1	F027	10-24 x 5/8 PPHMS		4
11	8403-2	Hydraulic Hose, Lift / Front (16)	1	F106	3/8-16 x 5/8 Hex Bolt		2
12	5975-7	Cable Tie (50# x 11")	2	F185	1/4 Int. Star Lock Washer, SS		1
13	8404-2	Hydraulic Valve Box	1	F232	10-32 Keps Nut		6
14	8403-4	Hydraulic Hose, Valve to Pump (17-1/2) A / Up	1	F397	1/4-20 x 3-3/8 Hex Bolt		2
15	8403-20	Hydraulic Hose, Valve to Pump (17-1/2) B / Down	1	F418	10-24 x 7/8 SHC Screw, GR5 (SS)		2
16	5975-1	Cable Tie (18# x 3-3/4")	11	* Service Part Only			
17	8403-19	Hydraulic Power Unit	1				
	8403-22	Motor Replacement	*				
18	6942	Relay Switch 30/40AMP(NC) (Includes Items # 31 & 32)	1				
19	8440-6	Relay Harness	1				
20	8440-7	Battery/Relay Harness	1				
21	5832	Cable Clamp (1/2)	1				
22	8401-7	Junction Block (10-32)	2				
23	7941	Circuit Breaker 40 Amp (Auto Reset/Sealed)	1				
24	8404-9	Plastic Cover, Black	1				
25	8404-8	Plastic Cover, Red	1				
26	6623-3	Toggle Switch / SP / DT	1				
27	6623-2	Toggle Switch / DP / DT	1				
28	8440-3	Jumper Wire	1				
29	8440-5	Wire Harness / Hi-Dump	1				
30	7833	Cable Clamp (7/8 x 1/4)	1				
31	6941-6	Relay Switch 30/40 Amp	*				
32	6941-7	Relay Mount	*				
33	8553	Splice Tap (18-14 Ga.)	1				
34	8440-10	Wire Assembly (3")	1				

Use only genuine **Walker®** replacement parts.

Effective Date 04-01-09

HI-DUMP KIT - HYDRAULIC

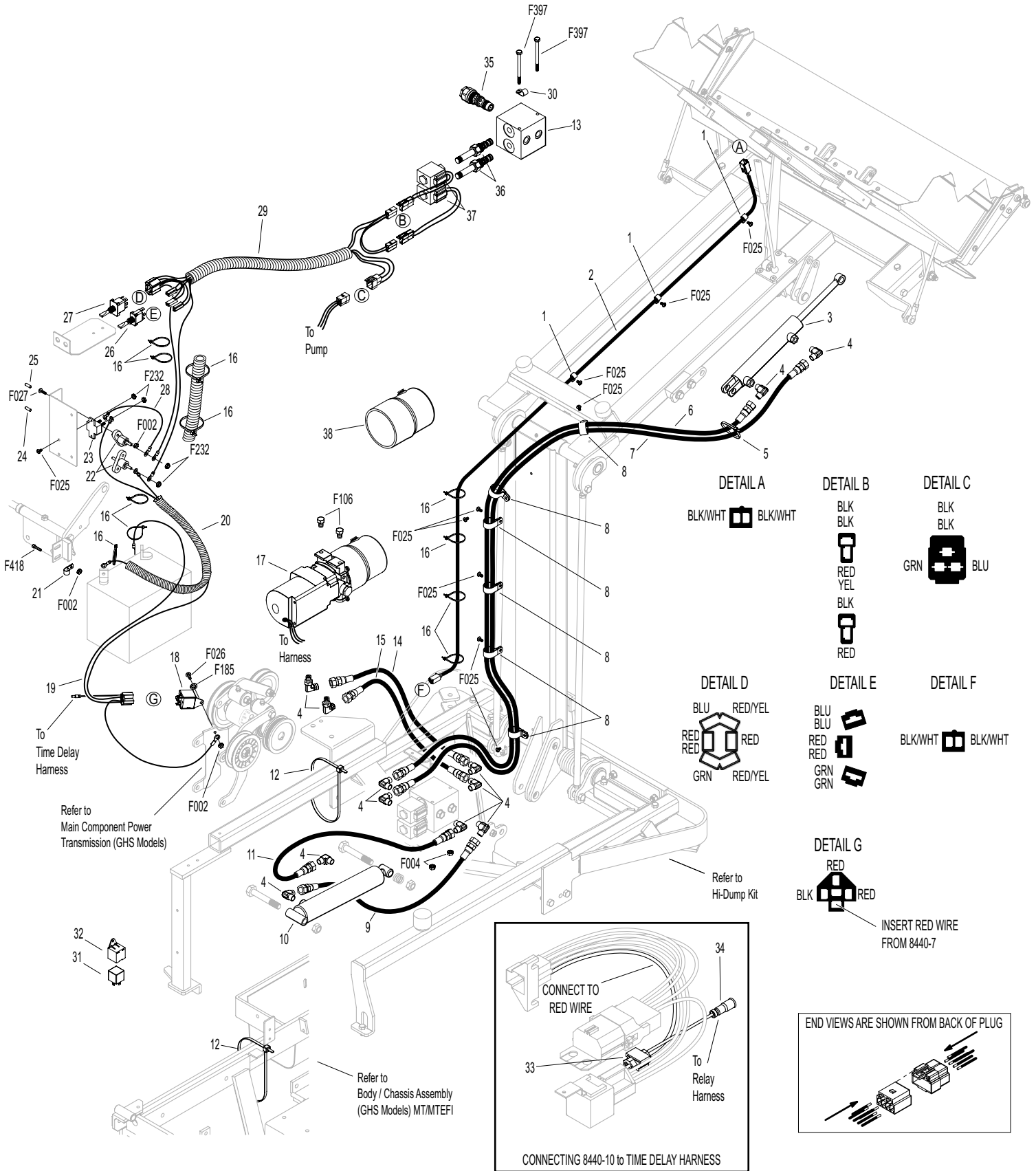

DETAIL A

BLK/WHT BLK/WHT

DETAIL B

BLK
BLK
 RED
YEL
BLK
 RED

DETAIL C

BLK
BLK
 GRN BLU

DETAIL D

BLU RED/YEL
 RED
RED
GRN RED/YEL

DETAIL E

BLU BLU
RED RED
RED GRN
GRN GRN

DETAIL F

BLK/WHT BLK/WHT

DETAIL G

RED
BLK RED

INSERT RED WIRE FROM 8440-7

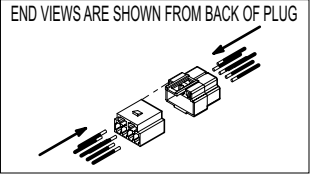

NO CATCH DEFLECTOR KIT / TAIL WEIGHT KIT / SPREAD TAIL WHEEL AXLE KIT

ITEM NO.	PART NO.	DESCRIPTION	NO. REQ'D
----------	----------	-------------	-----------

Kit 7500 (7.0 Bushel) No Catch Deflector Option / Kit
Includes Items # 1-5, fasteners and instructions.

No-Catch Deflector kits may be ordered as a dealer-installed option. Contact your Walker dealer.

1	7500	No-Catch Deflector Kit (7.0)	1
2	8500-5	Side Bracket	2
3	8787-2	Knob, Threaded Insert (1/4-20)	1
4	8500-6	Spacer Lug	1
5	8500-8	Decal, No Catch Deflector	1

Kit 7647 Tail Weight Option / Kit
Includes Items # 6, F012, F039 and instructions. May be ordered as a dealer-installed option. Contact your Walker dealer.

6	7647-9	Tail Weight Strap	2
7	7647-5	Tail Weight Plate, 10-lb	*

Kit 7647-1 Tail Weight Kit / MTL
Includes Items # 8, F012, F039 and instructions. May be ordered as a dealer-installed option. Contact your Walker dealer.

7	7647-5	Tail Weight Plate, 10-lb	*
8	7647-8	Tail Weight Strap (MTL)	2

Kit 7420-3 Spread Axle Kit/Less Wheels
Includes Items # 9-22, fasteners listed and instructions. May be ordered as a dealer-installed option. Contact your Walker dealer.

9	7420-6	Washer (2-1/2)	1
10	7420-11	Mount, Spread Axle	1
11	8769-8	Dust Cap, Deck Caster	2
12	8769-6	Bearing Cone (1" ID)	4
13	8769-5	Bearing Cup	4

ITEM NO.	PART NO.	DESCRIPTION	NO. REQ'D
----------	----------	-------------	-----------

14	7420-4	Fork Mount Tube (Includes Item # 13)	1
15	8769-7	Seal	2
16	7420-2	Tail Fork, Spread Axle	2
17	8039	Nut, Tail Wheel Axle	2
18	8038-1	Spacer, Tail Wheel Axle	2
19	7038	Tail Wheel Axle (3/4 x 5-9/16)	2
20	5683	Pivot Bearing	2
21	5830	Grease Fitting	3
22	7420-9	Pivot Shaft	1

Fasteners

F002	10-24 Keps Nut	4
F012	3/8-16 Keps Nut	10
F016	1/2-13 Self-Locking Nut	2
F030	1/4-20 x 1/2 PPH Bolt	1
F039	3/8-16 x 1-1/4 Hex Bolt	6
F128	10-24 x 3/8 PTHMS	4
F140	7/16-14 x 1 Hex Bolt	4
F146	1/4-20 Jam Nut	1
F175	1/2 Split Lock Washer	2**
F205	5/16-18 x 1/4 Set Screw	2
F218	7/16 Split Lock Washer	4
F285	1/2-13 x 1-1/2 Hex Bolt	2**
F333	1/4-20 x 3/4 PTHMS	1
F344	3/4-16 Slotted Hex Nut	2
F347	3/4 SAE Washer	2
F348	1/8 x 1-1/2 Cotter Pin	2
F377	1/2-13 x 5 Hex Bolt	1
F423	1/2-13 x 6-1/2 Hex Bolt	1

* Optional

** Use with optional 10-lb plate.

NOTE: If equipped, existing dual tail wheels and tires can be re-used with kit # 7420-3. Order kit # 7420-20 for two wheels and tires if tractor is equipped with a single wide tail wheel.

NO CATCH DEFLECTOR KIT / TAIL WEIGHT KIT / SPREAD TAIL WHEEL AXLE KIT

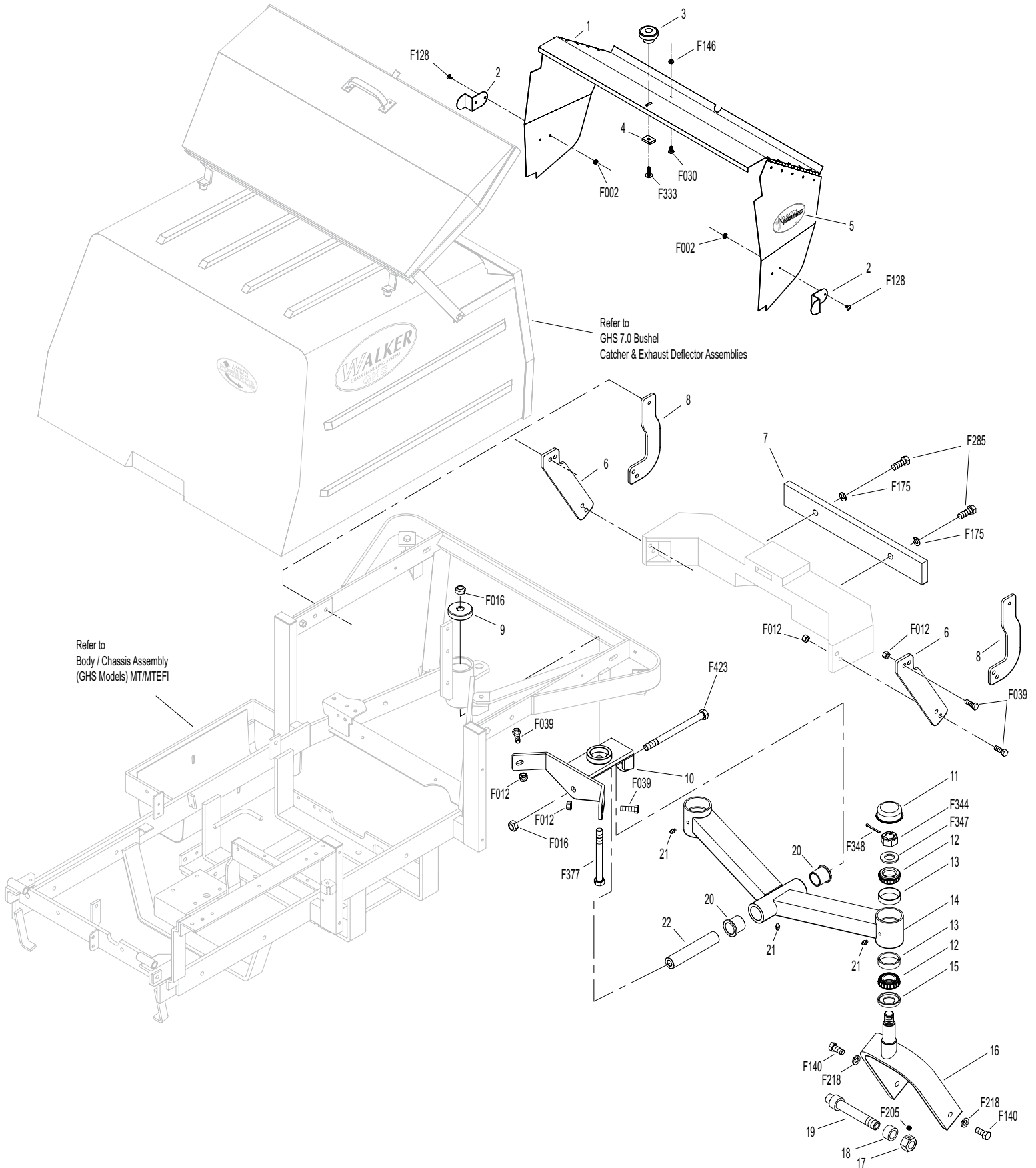

Effective Date 04-01-09

Use only genuine **Walker®** replacement parts.

TAIL WHEEL LOCK KIT / BLOWER LOCKOUT KIT / CASE-HARDENED BLOWER

ITEM NO.	PART NO.	DESCRIPTION	NO. REQ'D	ITEM NO.	PART NO.	DESCRIPTION	NO. REQ'D
Kit 8540 Tail Wheel Lock Option / Kit Includes Items # 1-28, fasteners listed & instructions. May be ordered as a dealer-installed option. Contact your Walker dealer.				Kit 7541 Blower Lockout Kit Includes Items # 29-35, fasteners and instructions. May be ordered as a kit for dealer installation. Contact your Walker dealer.			
1	5995-2	Switch Boot	1	29	7854	Plastic Tip, Red	*
2	8547	Switch Mount	1	30	6541-2	Blower Lockout Rod (Includes Item # 29)	1
3	8555	Decal, Tail Lock Switch	1	31	6541-1	Blower Lockout Latch	1
4	5995	Toggle Switch (Off-On)	1	32	5280	Clevis (1/4)	1
5	7942-4	Single Connector, Male	2*	33	5281-5	Clevis Pin (1/4 x 0.80)	1
6	5940-4	16-14 GA Spg. Loaded Term., Female	5*	34	6541-3	Blower Lockout Pivot Arm	1
7	5977-2	Grommet, Cut (1/8 x 3/8)	1	35	6541-4	Blower Lockout Belt Guide	1
8	5975-3	Cable Tie (50# x 7")	4	Kit Case Hardened Scroll Option			
9	8550	Wire Harness	1	36	7542-6	Blower Scroll (10.5) (Includes Item # 37)	*
10	5975-1	Cable Tie (18# x 3-3/4")	3	37	6542-50	Decal, "H" (5/8)	1
11	8553	Splice Tap (18-14 GA)	1	Fasteners			
12	8543	Solenoid Mount	1		F002	10-24 Keps Nut	4
13	5830-3	Grease Fitting (45 Degree)	1		F003	1/4-28 Hex Nut	2
14	8551	Ground Wire	1		F004	1/4-20 Keps Nut	5
15	8546	Solenoid, Control Module	1		F012	3/8-16 Keps Nut	2
16	5996	1/4 x 16-14 GA QDF Terminal	5*		F026	10-24 x 1/2 PPHMS	2
17	8552	Connector Plug & Wire Assy	1		F029	1/4-20 x 1/2 Hex Bolt	2
18	8544	Clevis, Wheel Lockout (9/16)	1		F032	1/4-20 x 3/4 Hex Bolt	1
19	5551-1	Pivot Bearing	2*		F038	3/8-16 x 1 Hex Bolt	2
	8545-1	Pivot Bearing Assembly (Includes Items # 19, 20, F179 & F350)	*		F050	1/4 SAE Washer	2
20	8544-1	Bearing Spacer (1/4 ID x 9/16)	1*		F091	5/16-18 x 5/8 Hex Bolt	1
21	8542	Tail Wheel Fork, Locking	1		F134	AN960816L Washer	1
22	8944	3-Way Locking Connector, Male	1*		F179	1/4-20 x 1 Hex Bolt	2
23	8944-1	3-Way Locking Connector, Female	1*		F186	5/64 x 1/2 Cotter Pin	1
24	5940-5	16-14 GA Spg. Loaded Term., Male	1*		F190	#10 Internal Star Lock Washer	1
25	5996-13	16-14 GA Ring Term., #10	1*		F198	.250 x .625 x .040 Washer, SS	1
26	7929	Actuating Solenoid	1		F298	3/8-24 Jam Nut	1
27	8549	Sleeve, Delrin	1		F299	10-24 x 1 PPHMS	2
28	8541	Plunger Rod	1		F300	1.015 x 1.500 x .031 Washer	1
	8554	Solenoid & Mount Assembly (Includes Items # 12-15, 17-20, 26-28, F002, F003, F004, F029, F050, F179, F190, F198, F298, F299 & F350)	*		F325	1/4-20 x 3 Hex Bolt	1
					F350	1/4-20 LP Nylock	1

* Service Part Only

NOTE: Refer to **ELECTRICAL CONNECTORS**, Page 64 for identification of all Electrical Wiring Service Parts.

TAIL WHEEL LOCK KIT / BLOWER LOCKOUT KIT / CASE-HARDENED BLOWER

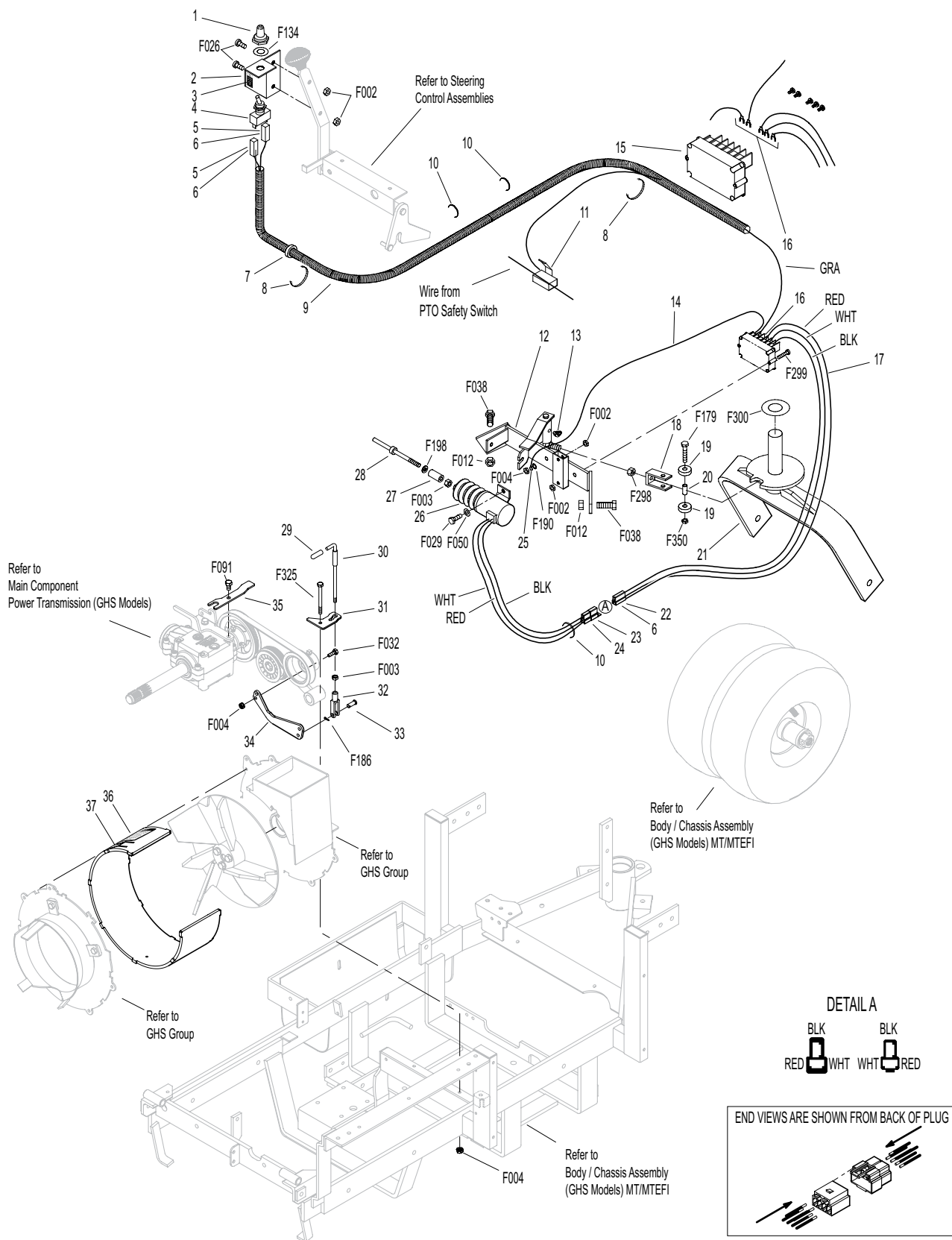

WIDE TAIL WHEEL / ALL-TERRAIN TIRE KIT & TIRE CHAIN SET

ITEM NO.	PART NO.	DESCRIPTION	NO. REQ'D
----------	----------	-------------	-----------

Kit 8049 Wide Tail Wheel Option / Kit

Includes Items # 1, 3 and instructions. May be ordered as a dealer-installed option. Contact your Walker dealer.

1	8037-1	Seal, Outer (1-3/4 x 1-1/8)	2
2	8048	Wide Tail Wheel Axle	1
3	8045	Wide Tail Wheel & Tire (13 x 8.00-6)	1
	8045-1	Wide Tire (13 x 8.00-6)	*
	8047	Wheel & Hub (6 x 7)	*

AT8072 All-Terrain Tire Option

Includes Item # 4 and instructions. May be ordered as a dealer-installed option. Contact your Walker dealer.

4	8070-6	AT Wheel & Tire RH/LH (18 x 11-10)	2
	8070-7	AT Tire RH/LH (18 x 11-10)	*
	8070-8	AT/LP Wheel (10 x 8.5)	*
	8075-2	AT/LP Tire Tube (18 x 11-10)	*
5	8070-31	Wheel Spacer Plate (1/2)	2

ITEM NO.	PART NO.	DESCRIPTION	NO. REQ'D
----------	----------	-------------	-----------

Kit LP8075 Low Profile Tire Option / Kit

Includes Item # 6 and instructions. May be ordered as a factory-installed option, or as a kit for dealer installation. Contact your Walker dealer.

6	8075	LP Wheel & Tire (18 x 10.5-10)	2
	8075-1	LP Tire (18 x 10.5-10)	*
	8070-8	AT/LP Wheel (10 x 8.5)	*
	8075-2	AT/LP Tire Tube (18 x 11-10)	*

Optional Tire Chain Set

7	5675-3	Tire Chain Set (18 x 9.50-8)	1
---	--------	------------------------------	---

* Service Part Only

WIDE TAIL WHEEL / ALL-TERRAIN TIRE KIT & TIRE CHAIN SET

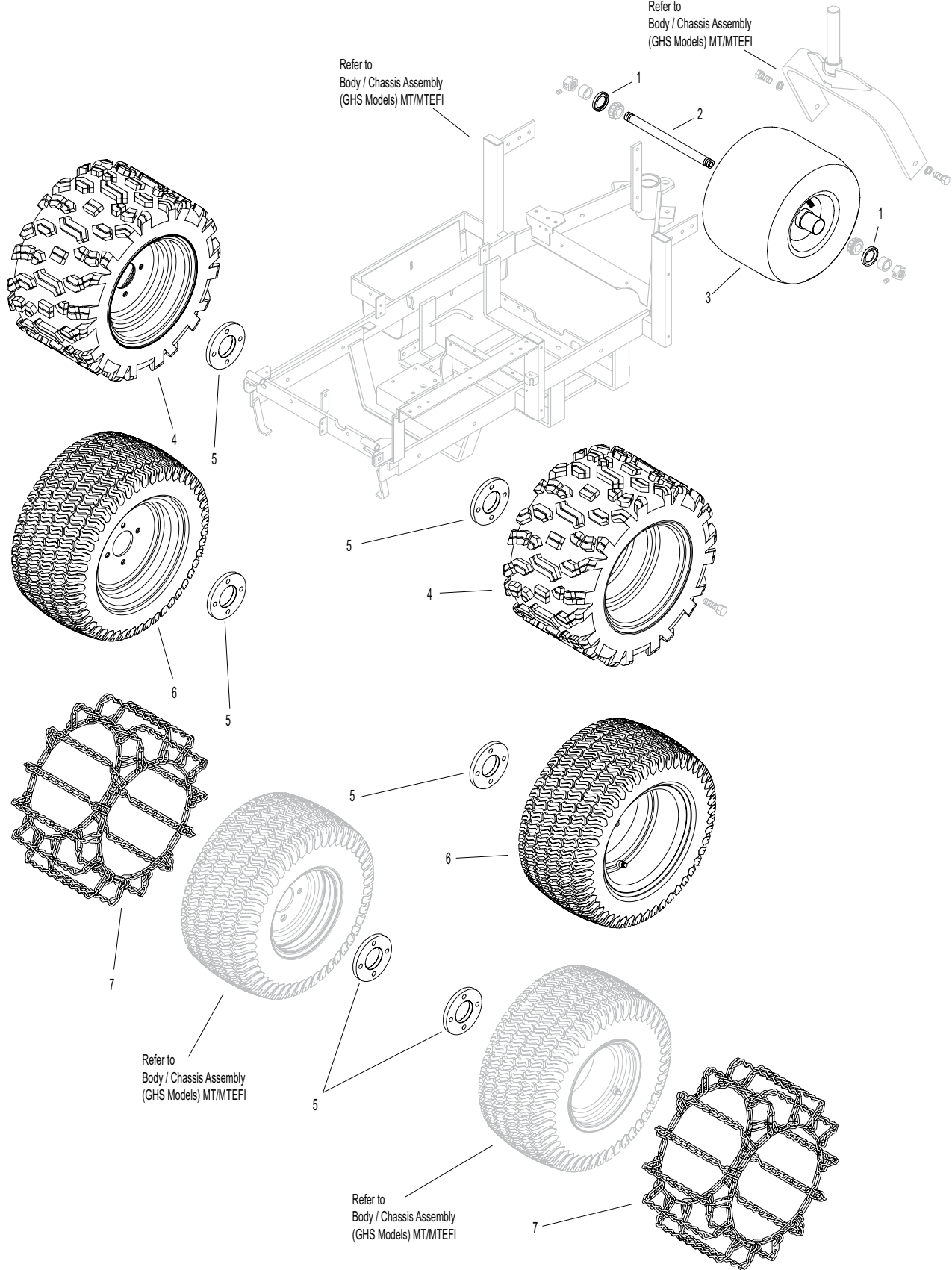

LUBRICATION POINTS

ITEM NO.	LOCATION	LUBRICATION TYPE	NO. PLACES	ITEM NO.	LOCATION	LUBRICATION TYPE	NO. PLACES
Lubrication Points				25	Brake Actuator Rod and Brake Band Pivot Pins (Clevis)	Oil	3
1	Deck Caster Wheel Fork Pivot	Grease	2	26	Brake Actuator Pivot	Grease	1
2	Deck Caster Wheel Bearing	Grease	2	27	Catcher Hinge Point	Oil	2
3	Tee Gearbox, Deck	Oil*	1	28	Rear Wheel Bearings	Grease	2
4	Blade Drive Gearbox	Oil*	2	29	Engine Oil	Oil***	1
5	Universal Joint Shaft Assembly	Grease**	1	30	Choke Control Cable Ends (Models MT and MTL only)	Oil	2
6	Pivot Assembly, Tilt-Up Deck	Grease	4	31	Belt Tightener Pivot, Blower Drive (GHS Model Only)	Grease	1
7	Deck Support Arm Socket	Grease	2	32	Belt Tightener Pivot, Ground Drive	Grease	1
8	Body Hinge Point	Oil	2	33	PTO Gearbox Dipstick	Oil***	1
9	FSC Actuator Rod Pivot Pins	Oil	2	34	Hydrostatic Drive	Oil***	2
10	FSC Lever Pivot	Grease	1	35	Choke Control Pivot (Models MT and MTL only)	Oil	1
11	FSC Lever Fork (Grease Slide Area)	Grease	1	36	Throttle Control Pivot	Oil	1
12	(FSC) Friction Body Pivot	Grease	1				
13	Steering Lever Pivot	Grease	4				
14	Deck Support Arm Pivot	Grease	2				
15	Deck-to-PTO Coupling (Grease Slide Area)	Grease	1				
16	Universal Joint Tube Assembly	Grease**	1				
17	Universal Joint Quick Connect Spline (Grease Slide Area)	Grease	1				
18	Parking Brake Lever	Grease	1				
19	Gear Axle	Oil***	2				
20	Belt Tightener Pivot, Jackshaft Drive	Grease	1				
21	Throttle Control Cable Ends	Oil	2				
22	Clutch Actuator Push Rod	Grease	2				
23	PTO Clutch Lever Pivot	Grease	1				
24	Belt Tightener Pivot, PTO Clutch	Grease	1				

* Gearboxes are permanently lubricated and sealed requiring no scheduled lubrication. Oil level should be checked only when an oil leak is noted.

** Grease every eight (8) hours.

*** Refer to MT **Owner's Manual** for procedure for checking and changing oil in Engine Crankcase, Hydrostatic Transmissions and Gear Axles.

NOTE: See Model MT **Owner's Manual** (P/N 8000-14) for proper lubrication intervals.

NOTE: DGHS42 Tilt-Up Deck is shown for reference. For other Deck Lubrication Points, Refer to Deck and Carrier Frame **Illustrated Parts Manual**.

LUBRICATION POINTS

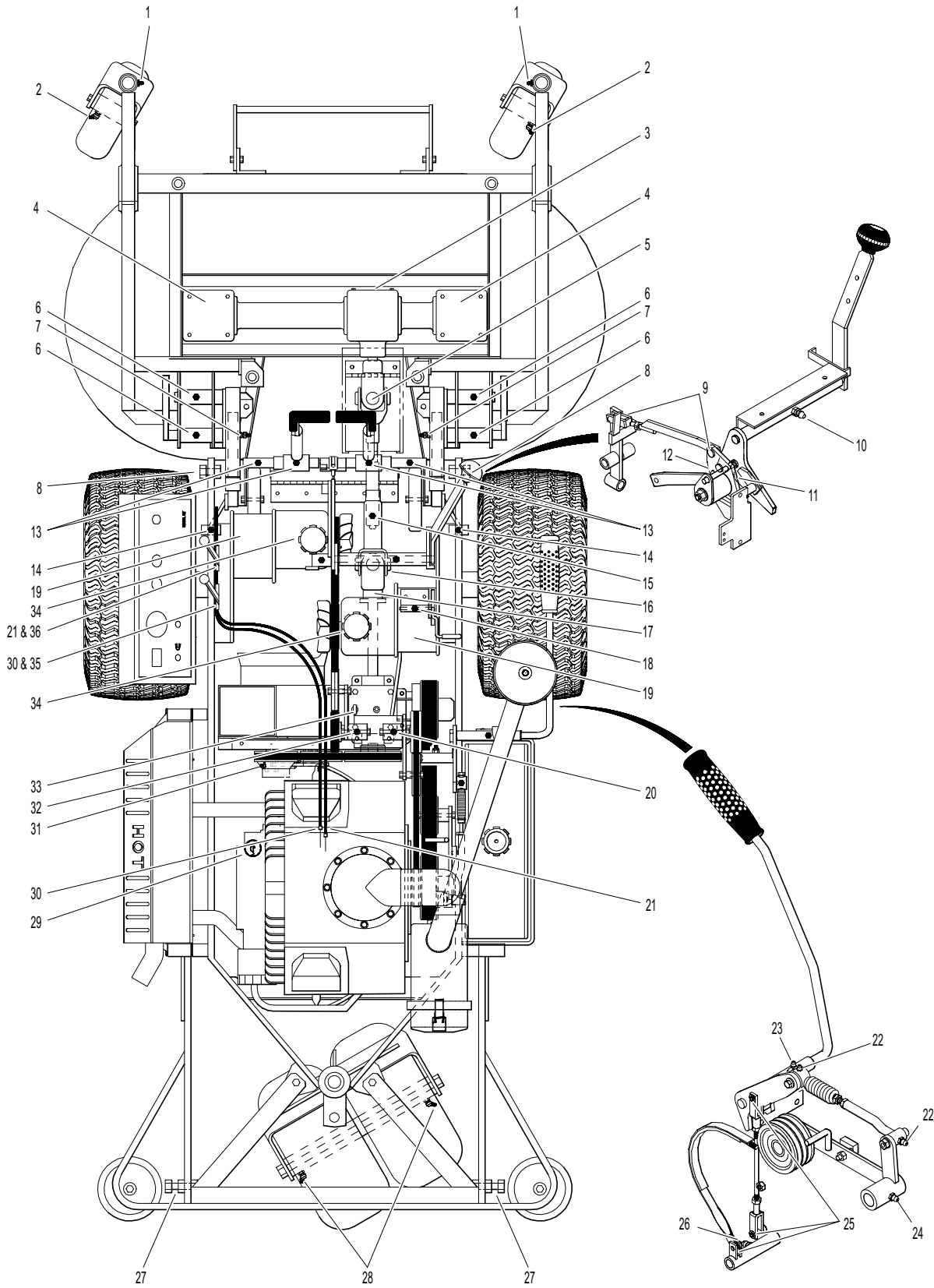

WIRING SCHEMATIC (MT)

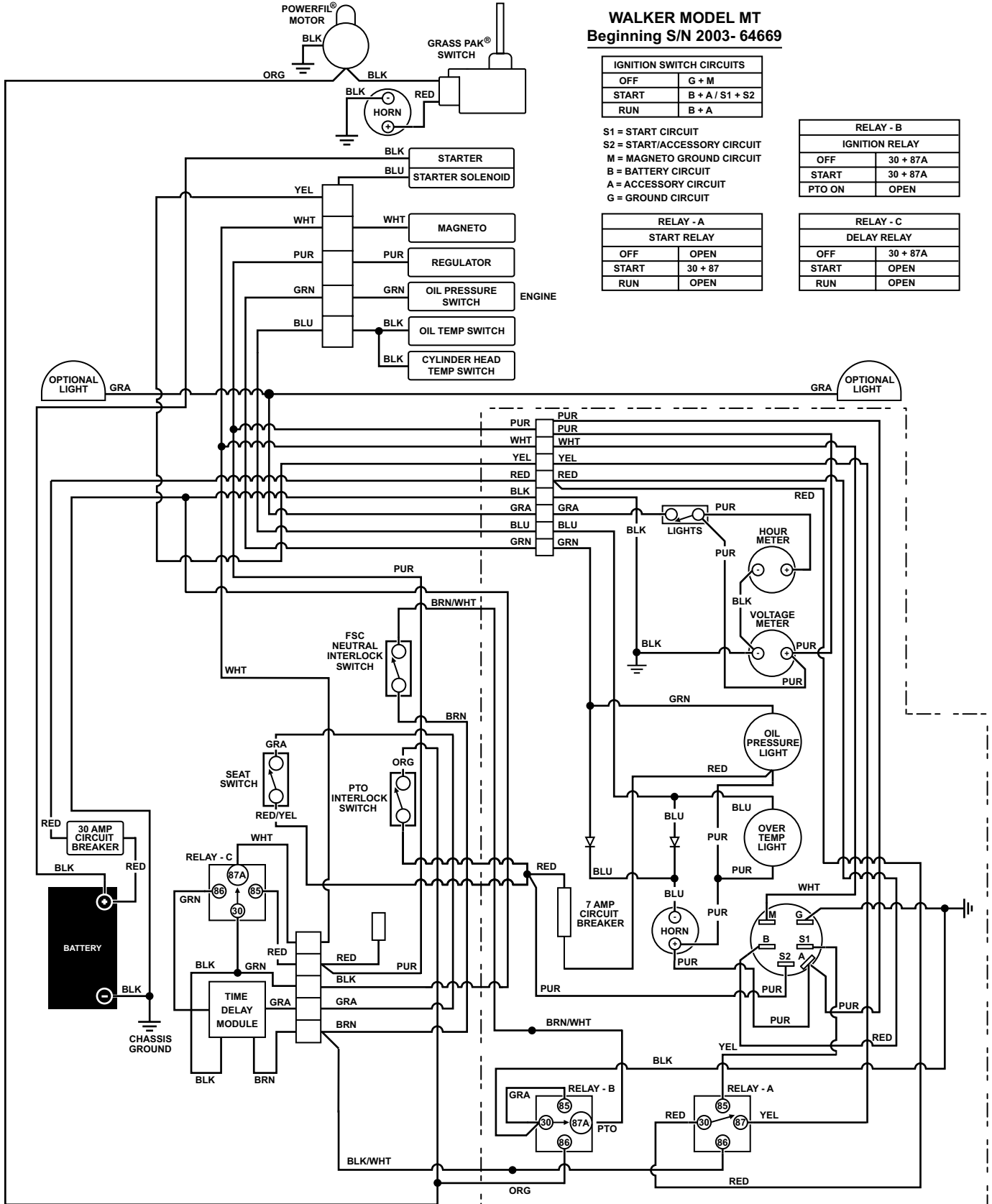

Use only genuine Walker® replacement parts.

Effective Date 04-01-09

WIRING SCHEMATIC (MTL)

WALKER MODEL MTL
Beginning S/N 2008-97112

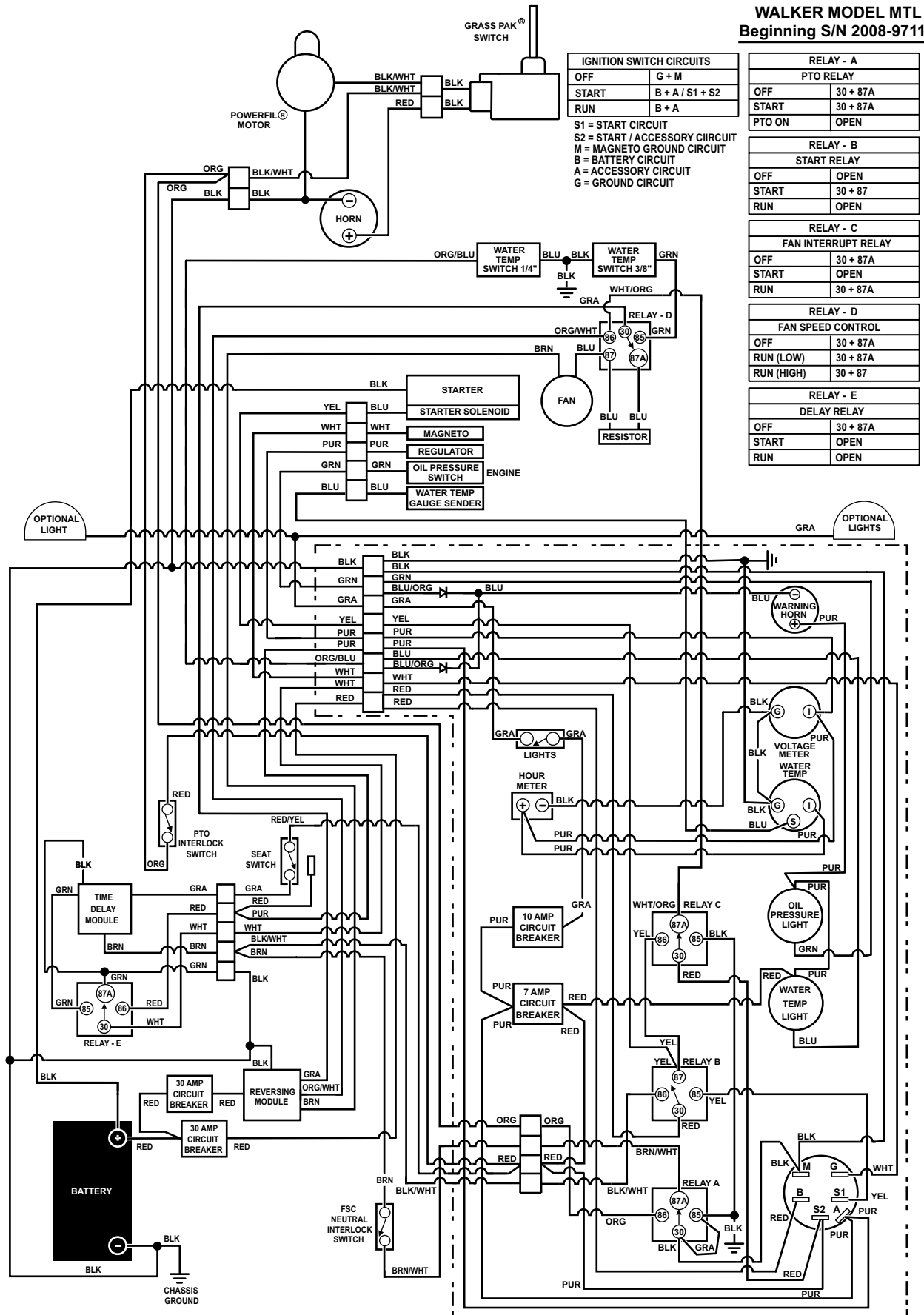

IGNITION SWITCH CIRCUITS	
OFF	G + M
START	B + A / S1 + S2
RUN	B + A

S1 = START CIRCUIT
S2 = START / ACCESSORY CIRCUIT
M = MAGNETO GROUND CIRCUIT
B = BATTERY CIRCUIT
A = ACCESSORY CIRCUIT
G = GROUND CIRCUIT

RELAY - A	
PTO RELAY	
OFF	30 + 87A
START	30 + 87A
PTO ON	OPEN

RELAY - B	
START RELAY	
OFF	OPEN
START	30 + 87
RUN	OPEN

RELAY - C	
FAN INTERRUPT RELAY	
OFF	30 + 87A
START	OPEN
RUN	30 + 87A

RELAY - D	
FAN SPEED CONTROL	
OFF	30 + 87A
RUN (LOW)	30 + 87A
RUN (HIGH)	30 + 87

RELAY - E	
DELAY RELAY	
OFF	30 + 87A
START	OPEN
RUN	OPEN

WIRING SCHEMATIC (MTEFI)

WALKER MODEL MT-EFI Beginning S/N 2003-64669

IGNITION SWITCH CIRCUITS	
OFF	G + M
START	B + A / S1 + S2
RUN	B + A

S1 = START CIRCUIT
 S2 = START / ACCESSORY CIRCUIT
 M = MAGNETO GROUND CIRCUIT
 B = BATTERY CIRCUIT
 A = ACCESSORY CIRCUIT
 G = GROUND CIRCUIT
 J1 = #1 FUEL INJECTOR
 J2 = #2 FUEL INJECTOR
 J3 = THROTTLE POSITION SENSOR
 J4 = OIL TEMP SENSOR
 J5 = OXYGEN SENSOR
 J6 = REGULATOR / RECTIFIER
 J8 = ENGINE GROUND
 J10 = #1 IGNITION COIL
 J11 = #2 IGNITION COIL
 J12 = #1 IGNITION COIL
 J13 = #2 IGNITION COIL
 J14 = IGNITION COIL GROUND
 J20 = SPEED PICK-UP SENSOR

RELAY - A	
IGNITION / FUEL RELAY	
OFF	OPEN
START	OPEN
PTO ON	30 + 87

RELAY - B	
DELAY RELAY	
OFF	30 + 87A
START	OPEN
RUN	OPEN

RELAY - C	
START / TIME DELAY RELAY	
OFF	30 + 87A
START	30 + 87A
RUN	OPEN

RELAY - D	
START / SOLENOID RELAY	
OFF	OPEN
RUN (LOW)	OPEN
RUN (HIGH)	30 + 87

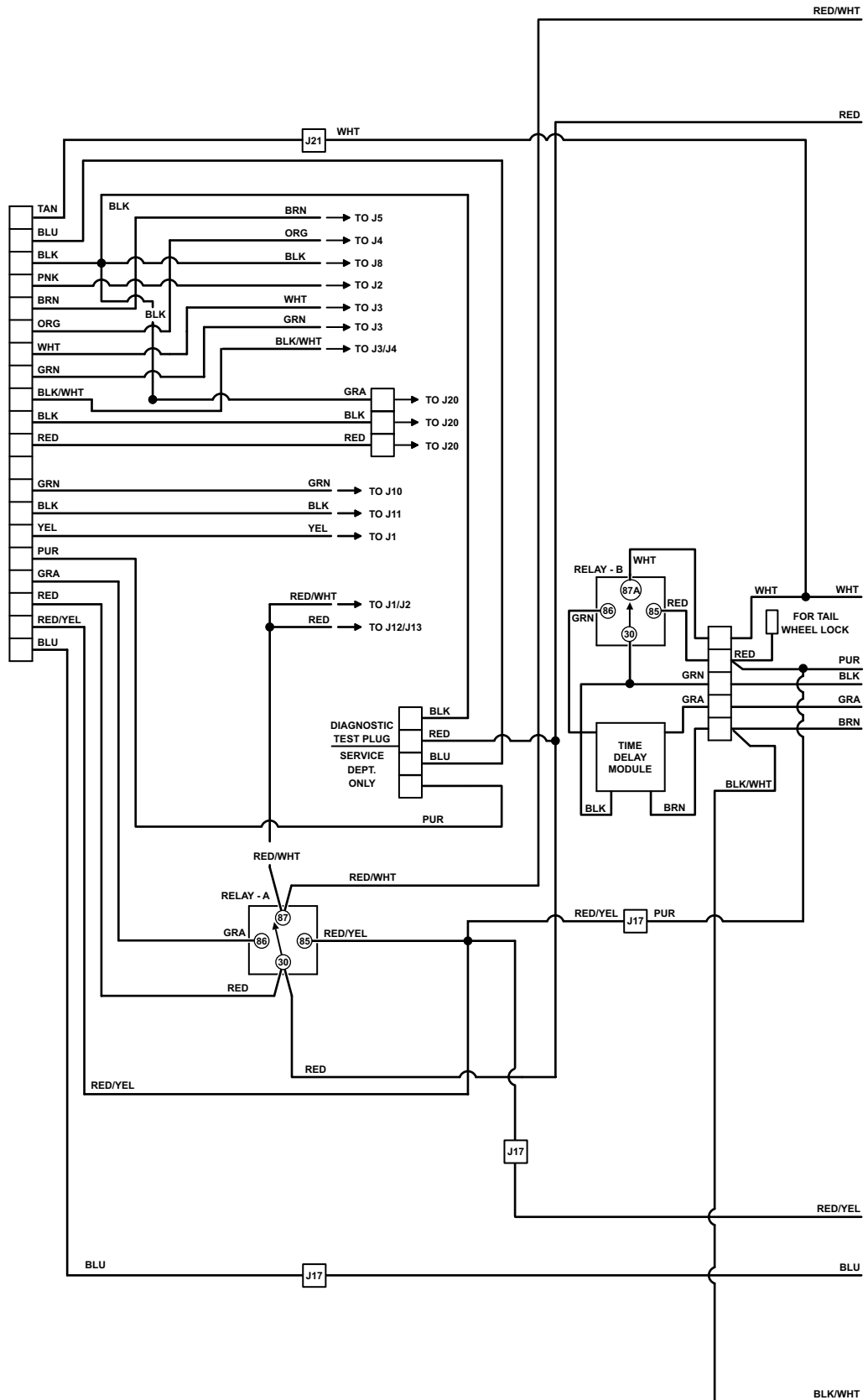

WIRING SCHEMATIC (MTEFI)

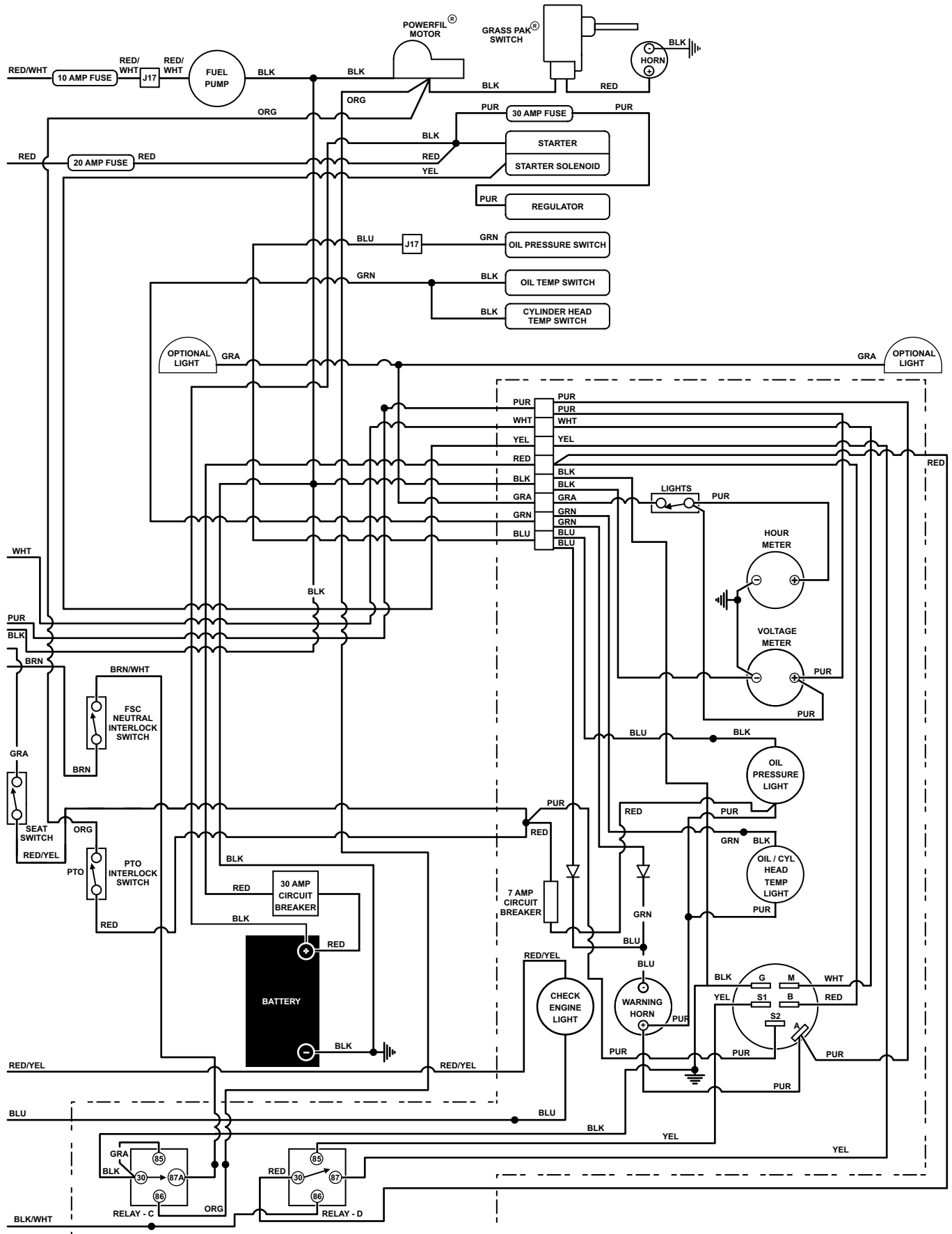

Effective Date 04-01-09

Use only genuine **Walker**® replacement parts.

WIRING SCHEMATIC (MTLEFI)

WALKER MODEL MTL-EFI Beginning S/N 2008-97112

- S1 = START CIRCUIT
- S2 = START / ACCESSORY CIRCUIT
- M = MAGNETO GROUND CIRCUIT
- B = BATTERY CIRCUIT
- A = ACCESSORY CIRCUIT
- G = GROUND CIRCUIT
- J1 = #1 FUEL INJECTOR
- J2 = #2 FUEL INJECTOR
- J3 = THROTTLE POSITION SENSOR
- J4 = OIL TEMP SENSOR
- J5 = OXYGEN SENSOR
- J6 = REGULATOR / RECTIFIER
- J8 = ENGINE GROUND
- J10 = #1 IGNITION COIL
- J11 = #2 IGNITION COIL
- J12 = #1 IGNITION COIL
- J13 = #2 IGNITION COIL
- J14 = IGNITION COIL GROUND
- J20 = SPEED PICK-UP SENSOR

RELAY - A	
PTO RELAY	
OFF	30 + 87A
START	30 + 87A
PTO ON	OPEN

RELAY - B	
START RELAY	
OFF	OPEN
START	30 + 87
RUN	OPEN

RELAY - C	
FAN INTERRUPT RELAY	
OFF	30 + 87A
START	OPEN
PTO ON	30 + 87A

RELAY - D	
FAN SPEED CONTROL	
OFF	30 + 87A
START	30 + 87A
PTO ON	30 + 87

RELAY - E	
DELAY RELAY	
OFF	30 + 87A
START	OPEN
PTO ON	OPEN

RELAY - F	
IGNITION / FUEL RELAY	
OFF	OPEN
START	OPEN
PTO ON	30 + 87

IGNITION SWITCH CIRCUITS	
OFF	G + M
START	B + A / S1 + S2
RUN	B + A

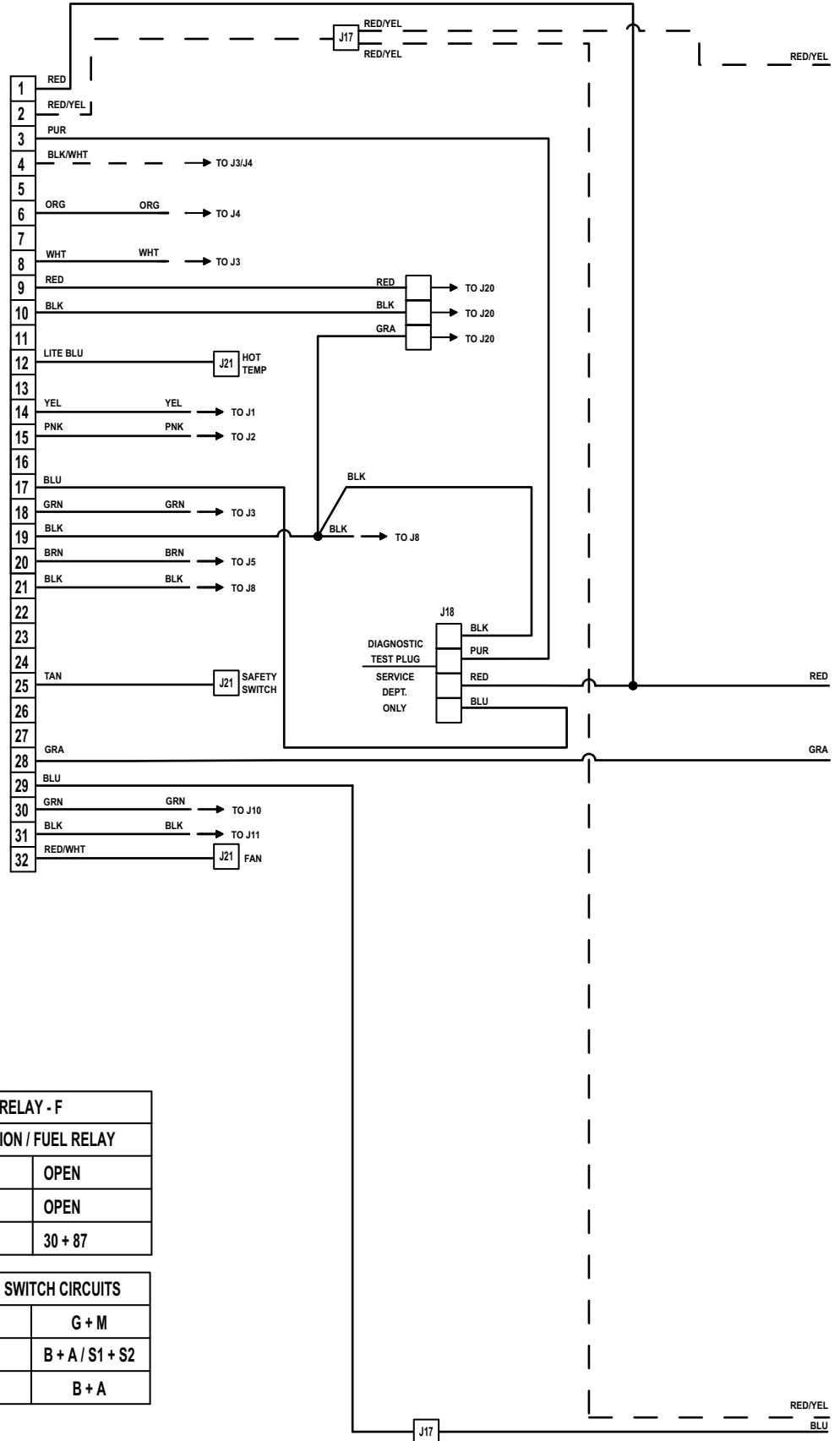

Use only genuine Walker® replacement parts.

Effective Date 04-01-09

WIRING SCHEMATIC (MTLEFI)

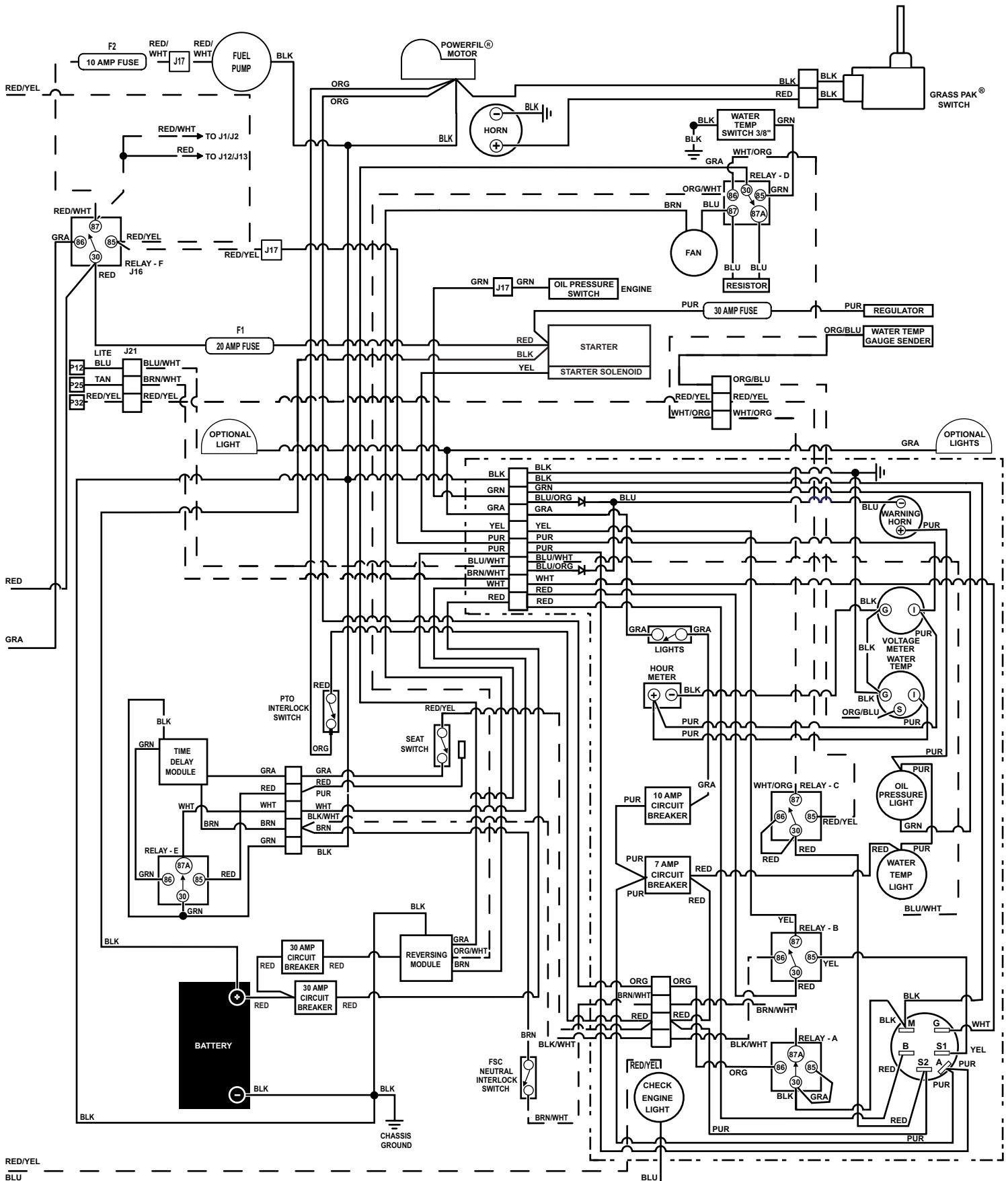

OPERATOR'S NOTES

LIMITED WARRANTY FOR WALKER COMMERCIAL RIDER MOWER

1. WHAT THIS WARRANTY COVERS, AND FOR HOW LONG:

Walker Manufacturing company will, at its option, repair or replace, without charge, any part covered by this warranty which is found to be defective in material and/or workmanship within one (1) year* after date of sale to the original retail purchaser unless the product is used for rental purposes, in which case this warranty is limited to ninety (90) days. At Walker's request, customer will make the defective part available for inspection by Walker and/or return the defective part to Walker, transportation charges prepaid. All parts and components of the Walker Mower are covered by this warranty **except** the following components which are warranted separately by their respective manufacturers:

Kohler Engine
Kubota Engine
Kawasaki Engine
Eaton Hydraulic Transmission
Peerless Gearboxes
Battery
Tires

The available warranties covering these items are furnished with each mower. Walker does not assume any warranty obligation, liability or modification for these items, which are covered exclusively by the stated warranty of the respective manufacturers noted above.

* An extended three (3) year warranty is offered on the Walker P/N 6200-9 Gear Axle Assembly.

2. WHAT THIS WARRANTY DOES NOT COVER:

- A. This warranty does not cover defects caused by depreciation or damage caused by normal wear, accidents, improper maintenance, improper use or abuse of the product, alterations, or failure to follow the instructions contained in the Owner's Manual for operation and maintenance.
- B. The customer shall pay any charges for making service calls and/or for transporting the mower to and from the place where the inspection and/or warranty work is performed.

3. HOW TO OBTAIN SERVICE UNDER THIS WARRANTY:

Warranty service can be arranged by contacting the dealer where you purchased the mower or by contacting Walker Manufacturing Company, 5925 East Harmony Road, Ft. Collins, CO 80528. Proof of the date of purchase may be required to verify warranty coverage.

4. WARRANTY LIMITATION:

- A. **THERE IS NO OTHER EXPRESS WARRANTY. ANY WARRANTY THAT MAY BE IMPLIED FROM THIS PURCHASE INCLUDING MERCHANTABILITY AND FITNESS FOR A PARTICULAR PURPOSE IS HEREBY LIMITED TO THE DURATION OF THIS WARRANTY AND TO THE EXTENT PERMITTED BY LAW ANY AND ALL IMPLIED WARRANTIES ARE EXCLUDED.** Some states do not allow limitations on how long an implied warranty lasts, so the above limitations may not apply to you.
- B. **WALKER WILL NOT BE LIABLE FOR ANY INCIDENTAL, CONSEQUENTIAL, OR SPECIAL DAMAGES AND/OR EXPENSES IN CONNECTION WITH THE PURCHASE OR USE OF THE MOWER.** Some states do not allow the exclusion or limitation of incidental or consequential damages, so the above limitation(s) or exclusion(s) may not apply to you.
- C. Only the warranty expressed in this limited warranty shall apply and no dealer, distributor, or individual is authorized to amend, modify, or extend this warranty in any way. Accordingly, additional statements such as dealer advertising or presentations, whether oral or written, do not constitute warranties by Walker, and should not be relied upon.
- D. This warranty gives you specific legal rights, and you may also have other rights which vary from state to state.

WALKER MOWERS™

WALKER MFG. CO. • 5925 E. HARMONY ROAD, FORT COLLINS, CO 80528 • (970) 221-5614
FORM NO. 040109 PRINTED IN USA www.walkermowers.com ©2009 WALKER MFG. CO