

Walker Rider Lawnmowers

ILLUSTRATED PARTS MANUAL

Model MT (23.0 HP)
Model MTL (25.0 HP)
Model MTEFI (26.0 HP)
Model MTLEFI (31.0 HP)

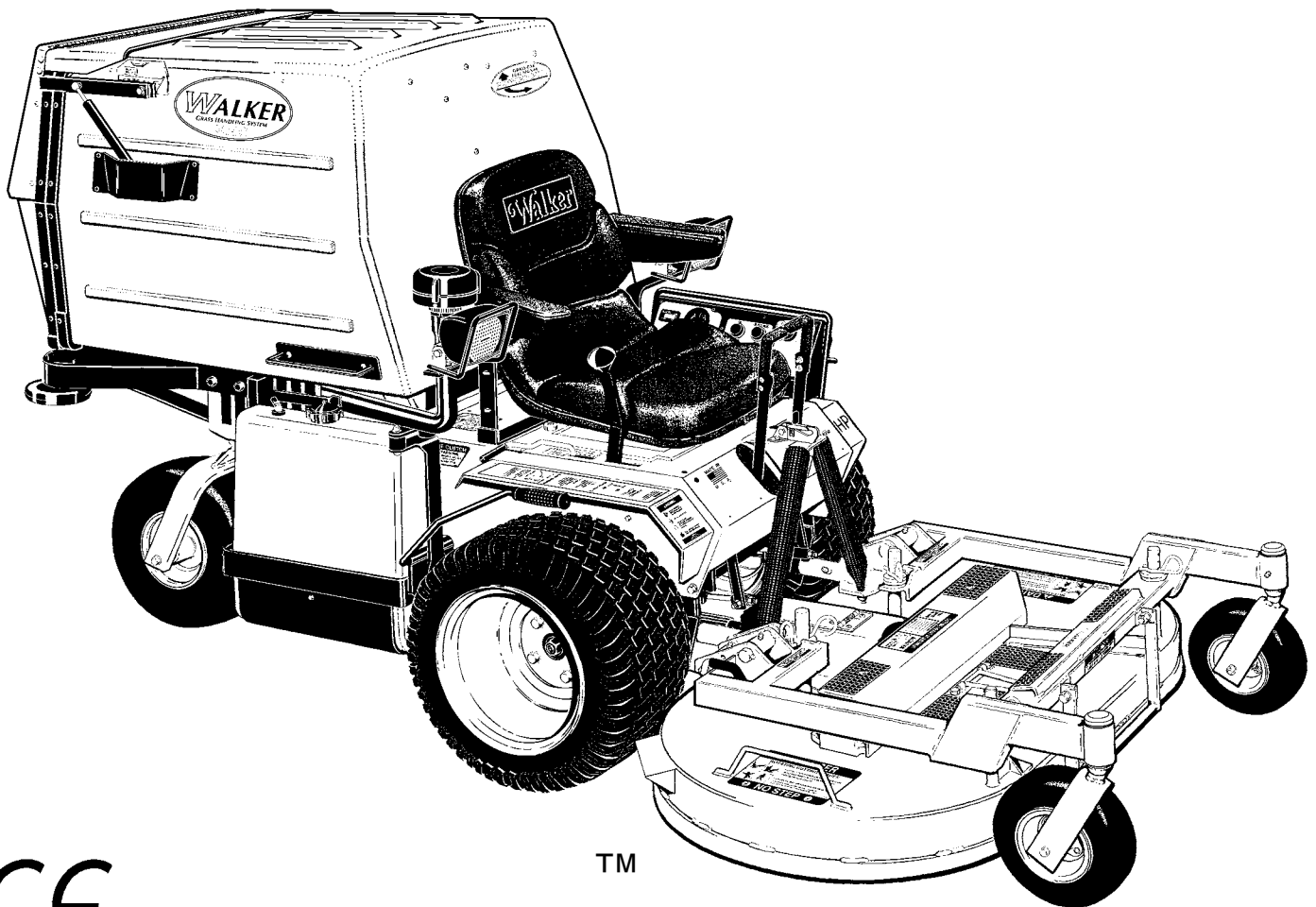

CE

TM

Effective Date:
04-01-07

P/N 8000-13

KEY TO ABBREVIATIONS USED IN THIS MANUAL

<i>Abbreviation</i>	<i>What it Represents</i>
° (Dimension)	Degrees (Angle)
" (Dimension)	inches
(-)	Negative (Polarity)
(+)	Positive (Polarity)
AT	All-Terrain
CCW	Counter-clockwise
Conn.	Connector
CW	Clockwise
D	Diameter
DGHS	Deck, Grass Handling System (number refers to size in inches)
DML	Deck, Mulching (number refers to size in inches)
DSD	Deck, Side Discharge (number refers to size in inches)
DU	Garlock (Bearing)
ESNA (Fastener)	Nylon Insert Locknut
FSC	Forward Speed Control
GA	Gauge
gal.	gallon
GHS	Grass Handling System
GR (Fastener)	Grade
HP	Horse Power
HT	Heat-Treated
ID	Identification or Inside Diameter
L	Length
LH	Left Hand (orientated with operator on seat)
LP	Low Profile
mm (Dimension)	millimeters
MS (Fastener)	Machine Screw
NS (as part number)	Item is not sold by Walker Manufacturing
OD	Outside Diameter
oz.	ounce
PFH (Fastener)	Phillips Flat Head
P/N	Part Number
PPH (Fastener)	Phillips Pan Head
PTH (Fastener)	Phillips Truss Head
PTO	Power Take-Off
QKS	Quick Slide
qt.	quart
RH	Right Hand (orientated with operator on seat)
SAE (Fastener)	Society of Automotive Engineers
SBH (Fastener)	Socket Button Head (Bolt)
SD	Side Discharge
SFH (Fastener)	Slotted Flat Head
SHC (Fastener)	Socket Head Cap
SHL (Fastener)	Shoulder (Bolt)
SM (Fastener)	Sheet Metal (Screw)
S/N	Serial Number
Spg.	Spring
SQH (Fastener)	Square Head
SS (Fastener)	Stainless Steel
ST (Fastener)	Self-Tapping (Screw)
Term.	Terminal
V	Volts

NOTE: In some instances, combinations of abbreviations may be used (e.g. PPHMS - Phillips Pan Head Machine Screw).

Use only genuine Walker® replacement parts.

Effective Date 04-01-07

ILLUSTRATED PARTS LIST

<i>Section of Mower Covered</i>	<i>Page</i>	<i>Section of Mower Covered</i>	<i>Page</i>
Decals		Electrical Components	
Tractor Decals	2	Electrical Assembly	
Body / Chassis Assemblies		(MT)	54
Body / Chassis Assembly		(MTL)	56
(GHS Models) MT/MTEFI	4	(MTEFI)	58
(GHS Models) MTL/MTLEFI	6	(MTLEFI)	60
Rear Body Assembly		Electrical Assemblies	
(GHS Models) MT/MTEFI	8	(GHS 9.5 / 7.0 Bushel Components)	62
(GHS Models) MTL/MTLEFI	10	Electrical Connectors	64
Body Assembly		Options and Kits	
(SD Models) MT/MTEFI	12	Power Deck Lift Kit	66
(SD Models) MTL/MTLEFI	14	Armrest Kit / Touch-Up Paint / Comfort Seat Kit ...	68
Tractor Components		Suspension Seat Kit	70
Main Component Power Transmission		Light Kit / Cold Start Kit / Speed Up Kit	72
(GHS Models)	16	Power Dump Kit	
(SD Models)	18	(9.5 Bushel GHS Models Only)	74
Engine Group		(7.0 Bushel GHS Models Only)	76
(MT)	20	Hi-Dump Kit	78
(MTL)	22	Hi-Dump Kit - Hydraulic	80
(MTEFI)	24	No Catch Deflector Kit / Tail Weight Kit /	
(MTLEFI)	26	Spread Tail Wheel Axle Kit	82
Radiator Group (MTL/MTLEFI)	28	Tail Wheel Lock Kit / Blower Lockout Kit /	
Hydrostatic Ground Drive Assemblies	30	Case-Hardened Blower.....	84
Steering Control Assemblies	32	Wide Tail Wheel / All-Terrain Tire Kit &	
Throttle & Choke Control Assembly	34	Tire Chain Set	86
Parking Brake Assembly	36	Maintenance	
GHS Group	38	Lubrication Points	88
GHS Powerfil® Assembly	40	Wiring Schematic	
GHS 9.5 Bushel Catcher Assembly	42	(MT)	90
GHS 7.0 Bushel Catcher &		(MTL)	91
Exhaust Deflector Assemblies	44	(MTEFI)	92
Instrument Panel Assembly		(MTLEFI)	94
(MT)	46	Operator's Notes	96
(MTL)	48	Warranty	
(MTEFI)	50	Limited Warranty	97
(MTLEFI)	52		

TRACTOR DECALS

ITEM NO.	PART NO.	DESCRIPTION	LOCATION	NO. REQ'D. GHS	NO. REQ'D SD
Walker Product and Operation Decals					
1	7802	RH Fender	Body, RH Side Near Seat	1	1
2	5856	Made in USA	Body	1	1
3	5803	Walker Manufacturing Logo	Body	1	1
4	5813-1	Powerfil®	7.0 / 9.5 Bushel Catcher, Front	1	0
5	5801	GHS	7.0 / 9.5 Bushel Catcher (one on each side)	2	0
6	5800	Walker Mower (4 x 7-1/2)	Utility Bed (one on each side)	0	2
7	5806	Blade Clutch	Body, RH Side	1	1
Danger Decals Warning Decals Caution Decals					
8	5804	Danger, Rotating Blower Blades	Body, Near Body Chute	1	0
9	7818	Warning, Read Manual	Body	1	1
10	6810	Danger, Engine Exhaust	Engine	1	1
11	5868	Danger, Pinch Point	7.0 / 9.5 Bushel Catcher Mounting Frame Assembly (one on each side)	2	0
12	5844-2	Warning, Electric System	Battery Hold-Down Bar	1**	1**
13	5810-3	Decal, Hydro Warning	Bridge Assembly and LH Gear Axle Drive Assembly	2	2
Maintenance Decals					
14	7809	Parking Brake	Body, RH Side below Seat	1	1
15	8400-6	Body Latch Decal	Body, RH Side below Seat	1	1
16	7819	Throttle	Body, LH Side	1	1
17	8819	Choke	Body, LH Side	1	1
18	5855	Important, Engine Cooling	Engine	1	1
19	NS	Sealed Reservoir	Hydrostatic Drives (one on each)	2	2
20	5810-1	Axle Oil Level	Gear Axle Drive Assemblies (one on each)	2	2
21	5819	Blower Maintenance	Blower Housing	1	0
22	6875	PTO Alignment Arrow	Universal Joint Tube Assembly	1	1
23	7827	Oil Level	Jackshaft Support	1	1
24	5874	Push to Release	7.0 / 9.5 Bushel Catcher Safety Latch	1	0
25	8825	Front Body Closure	Rear Cross Member, Body	1	1
26	8821-1	23 HP	Body	1*	1*
	8822	25 HP	Body	1*	1*
	8822-10	26 HP	Body	1*	1*
	8822-12	31 HP	Body	1*	1*
27	5869	Removable Screen	7.0 / 9.5 Bushel Catcher Removable Screen	1	0
Option Decals (applied only to units with corresponding Options installed)					
28	7633	Power Dump Switch	Body	1	0
29	8555	Tail Lock Switch	FSC Lever Assembly - Switch Mount Bracket	1	1
30	8654	Power Deck Lift Switch	Body, RH Side	1	1
	8500-8	No Catch Deflector	7.0 / 9.5 Bushel No Catch Deflector, LH Side (Refer to 7.0 / 9.5 Bushel No Catch Deflector Kit Listing)	1	0

* 23 HP Decal is Standard. 25 HP Decal furnished only with 25 HP Engine Upgrade Option.
26 HP Decal furnished only with Optional 26 HP EFI Engine. 31 HP Decal furnished only with MTLEFI Option.

** Decal furnished only with fuel-injected models.

NOTE: All parts requiring decals are shipped with decals applied.

Use only genuine Walker® replacement parts.

Effective Date 04-01-07

TRACTOR DECALS

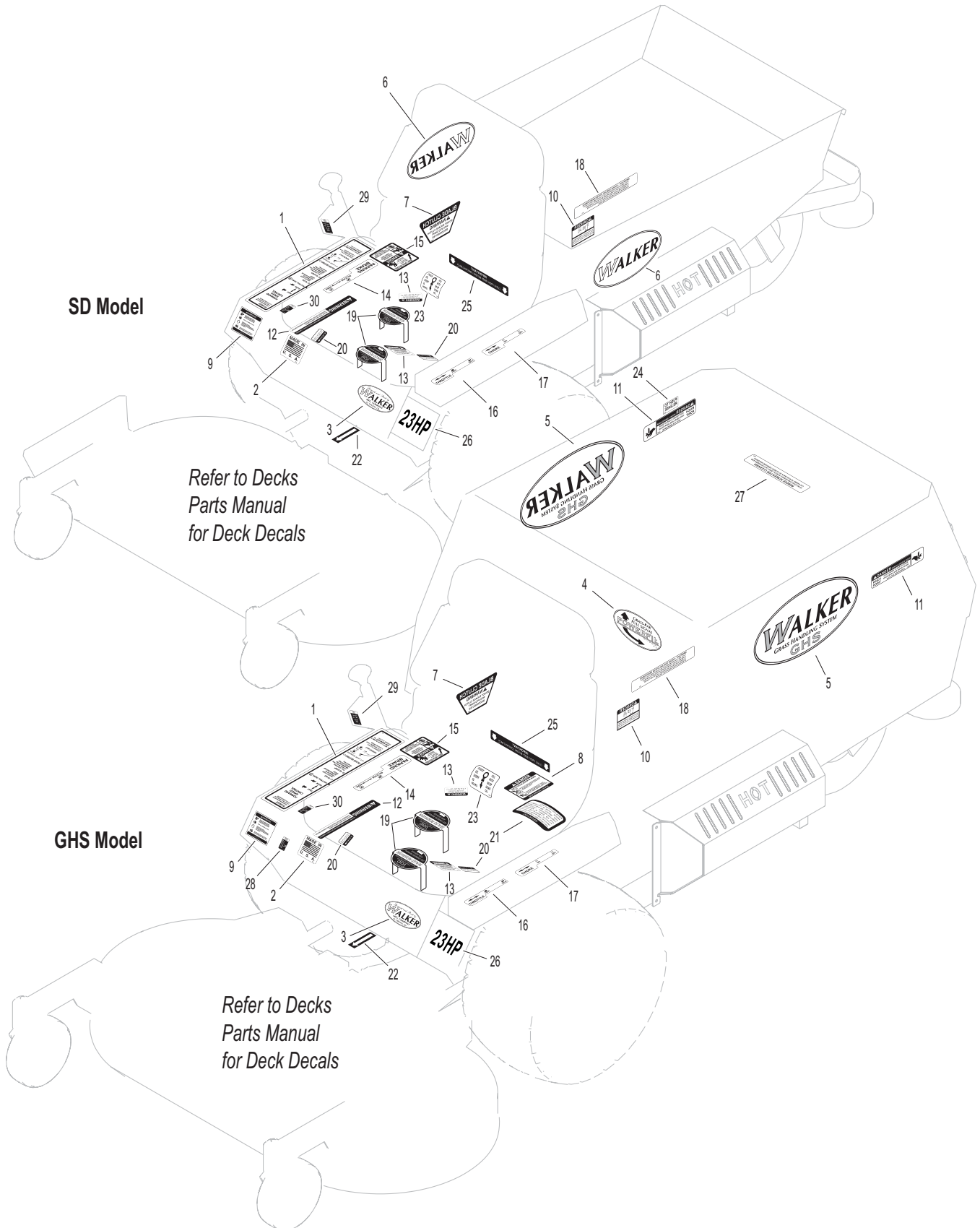

BODY / CHASSIS ASSEMBLY (GHS MODELS) MT/MTEFI

ITEM NO.	PART NO.	DESCRIPTION	NO. REQ'D	ITEM NO.	PART NO.	DESCRIPTION	NO. REQ'D
Seat Assembly				46	8038-1	Spacer, Tail Wheel Axle	2
1	5103	Seat	1	47	8037	Bearing Cone (3/4 ID)	4
2	7203	Seat Spring Plate	1	48	8035	Tail Wheel & Tire Assembly (13 x 5.00-6) (With Bearing Race)	2
3	7223-1	Compression Spring	2		7035-1	Tail Wheel Tire (13 x 5.00-6)	**
4	7845	Rubber Bumper (1.375 OD x .63)	2		8036	Wheel & Hub (6 x 3.25) (Includes Item # 43 & Bearing Race)	**
5	7846	Washer (3/8 ID x 1-1/4 OD x 1/8)	2		8037-2	Bearing Race	**
6	7204	Shoulder Bolt, Seat Mount	2	49	8768-2	Seal, Reverse Lip	2
7	7440-5	Shock Mount (1-1/4 x 3/4)	2	50	8038	Tail Wheel Axle (3/4 x 10-3/8)	1
Rear Bumper Assembly (GHS Models Only)*				51	7070	Wheel & Tire Assembly (18 x 9.5-8)	2
8	7516	7.0 / 9.5 Rear Bumper	1		7070-1	Drive Tire (18 x 9.5-8)	**
9	7516-5	Catcher Pivot Bushing	2		5070-4	Wide Wheel (8 x 7)	**
10	5162	Roller Wheel (5" Rubber)	2	52	8300-14	Chassis Frame (T/5.0 gal.)	1
11	7517-2	Catcher Pivot Plate	2		8300-16	Chassis Frame (EFI/5.0 gal.)	1
Body Assembly				Fasteners			
12	NS	Body ID Plate	1	F002	10-24 Keps Nut		2
13	5989-12	Dome Plug (3/16)	1	F004	1/4-20 Keps Nut		2
14	5989-10	Dome Plug (9/16)	1	F005	1/4-20 ESNA Nut		1
15	5845	Rubber Bumper (1.50 OD x 1.25)	4	F009	5/16-18 Whiz Locknut		12
16	8118	Heat Deflector	1	F012	3/8-16 Keps Nut		8
17	7422	Panel Guard	1	F013	3/8-16 Whiz Locknut		2
18	5989-4	Dome Plug (3/8)	4	F014	3/8-16 ESNA Nut		4
19	5989-3	Dome Plug (5/16)	2	F020	5/16-18 ESNA Nut		1
20	7146	13mm Ball Stud	2	F025	10-24 x 3/8 PPHMS		2
21	7844	Rubber Bumper (1.25 OD x .25)	1	F029	1/4-20 x 1/2 Hex Bolt		2
22	7147	Spring Clip	2	F031	1/4-20 x 5/8 Hex Bolt		1
23	7145	Gas Spring Assembly (Includes Items # 20 & 22)	1	F034	5/16-18 x 3/4 Hex Bolt		2
24	7222	Extension Spring (1/4 x 3)	1	F038	3/8-16 x 1 Hex Bolt		6
25	7383-2	Body Latch Hook	1	F040	3/8-16 x 1-1/2 Hex Bolt		2
26	7854	Plastic Tip, Red	1	F042	3/8-16 x 2-1/4 Hex Bolt		2
27	5989-9	Dome Plug (1/4)	8	F050	1/4 SAE Washer		1
28	8100-4	Front Body / T	1	F051	3/8 SAE Washer		2
	8100-5	Front Body / EFI	1	F059	3/8 Wave Spring Washer		2
29	5180	Edge Molding, Lever Opening	2	F093	5/16-18 x 1 Hex Bolt		1
30	5989-55	Dome Plug (1/2)	1	F151	3/8-16 x 7/8 Hex Bolt		2
31	5989-5	Dome Plug (7/16)	1	F157	1/2-20 x 1-1/4 Wheel Lug Bolt		8
Tilt-Up Latch Assembly***				F205	5/16-18 x 1/4 Set Screw, Knurl Point		2
32	5847	Plastic Tip	1	F206	#2 x 3/16 Drive Pin		2
33	5744-20	Spring Arm, Tilt-Up Latch	1	F218	7/16 Split Lock Washer		2
34	5744-10	Spring Pivot Bushing	1	F219	7/16-14 x 1-1/4 Hex Bolt		2
35	5744-15	Compression Spring (3/8 x 5/8)	1	F227	3/8 x 1-1/4 x 1/8 Plastic Washer		2
36	5744-13	Mount Angle, LH	1	F241	.375 x .875 x .10 Washer		4
37	5744-12	Hook, Tilt-Up Latch	1	F341	Coil Roll Pin (7/64 x 9/16)		1
38	5744-14	Mount Angle, RH	1	F342	5/16 Conical Washer		2
Chassis Assembly				F413	5/16-24 x 5/16 Set Screw		2
39	5267-1	Retainer Collar (1") (Includes Item # F413)	1	* Rear Bumper Assembly for SD Models is not shown here. Refer to BODY ASSEMBLY (SD MODELS) MT/MTEFI , Page 12.			
40	5270-1	Pivot Bearing	2	** Service Part Only			
41	5842-1	Washer, Axle Spacer	1	*** Complete Tilt-Up Latch Assembly Kit available by ordering kit # 5747.			
42	7420	Tail Wheel Fork	1				
43	5830-3	Grease Fitting (45 Degree)	2				
44	8039	Nut, Tail Wheel Axle	2				
45	8037-1	Seal, Outer (1-3/4 x 1-1/8)	2				

Use only genuine Walker® replacement parts.

Effective Date 04-01-07

BODY / CHASSIS ASSEMBLY (GHS MODELS) MT/MTEFI

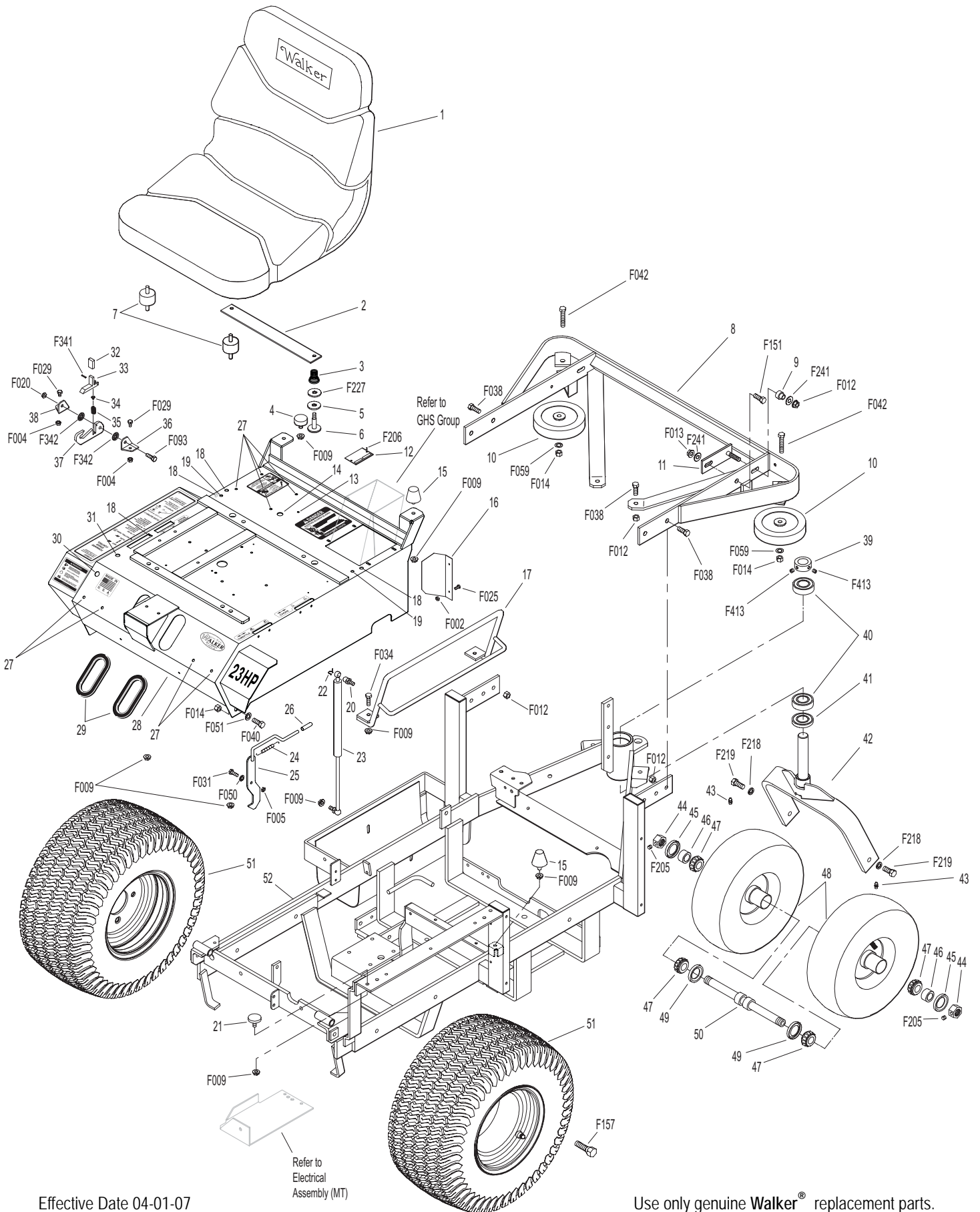

Effective Date 04-01-07

Use only genuine Walker® replacement parts.

BODY / CHASSIS ASSEMBLY (GHS MODELS) MTL/MTLEFI

ITEM NO.	PART NO.	DESCRIPTION	NO. REQ'D	ITEM NO.	PART NO.	DESCRIPTION	NO. REQ'D
Seat Assembly				46	8035	Tail Wheel & Tire Assembly (13 x 5.00-6)	2
1	6103-14	Suspension Seat	1			(With Bearing Race)	
2	6103-35	Suspension Seat Mount	2		7035-1	Tail Wheel Tire (13 x 5.00-6)	**
3	7440-7	Shock Mount	4		8036	Wheel & Hub (6 x 3.25)	**
4	6105-1	Shoulder Washer	2			(Includes Item # 41 & Bearing Race)	
Rear Bumper Assembly (GHS Models Only)*					8037-2	Bearing Race	**
5	7516-7	7.0 / 9.5 Rear Bumper	1	47	8768-2	Seal, Reverse Lip	2
6	7516-5	Catcher Pivot Bushing	2	48	8038	Tail Wheel Axle (3/4 x 10-3/8)	1
7	5162	Roller Wheel (5" Rubber)	2	49	7070	Wheel & Tire Assembly (18 x 9.5-8)	2
8	7517-2	Catcher Pivot Plate	2		7070-1	Drive Tire (18 x 9.5-8)	**
Body Assembly					5070-4	Wide Wheel (8 x 7)	**
9	7833-2	Cable Clamp (1 x 1/4)	1	50	8300-17	Chassis Frame	1
10	5977-3	Grommet (9/16)	1	Fasteners			
11	NS	Body ID Plate	1	F002		10-24 Keps Nut	3
12	5845	Rubber Bumper (1.50 OD x 1.25)	4	F004		1/4-20 Keps Nut	2
13	8118	Heat Deflector	1	F005		1/4-20 ESNA Nut	1
14	7422	Panel Guard	1	F009		5/16-18 Whiz Locknut	16
15	5989-4	Dome Plug (3/8)	4	F012		3/8-16 Keps Nut	8
16	5989-3	Dome Plug (5/16)	2	F013		3/8-16 Whiz Locknut	2
17	6105-3	Harness Clip	2	F014		3/8-16 ESNA Nut	4
18	7146	13mm Ball Stud	2	F020		5/16-18 ESNA Nut	1
19	7844	Rubber Bumper (1.25 OD x .25)	1	F025		10-24 x 3/8 PPHMS	3
20	7147	Spring Clip	2	F029		1/4-20 x 1/2 Hex Bolt	2
21	7145	Gas Spring Assembly	1	F031		1/4-20 x 5/8 Hex Bolt	1
		(Includes Items # 18 & 20)		F034		5/16-18 x 3/4 Hex Bolt	2
22	7222	Extension Spring (1/4 x 3)	1	F038		3/8-16 x 1 Hex Bolt	6
23	7383-2	Body Latch Hook	1	F040		3/8-16 x 1-1/2 Hex Bolt	2
24	7854	Plastic Tip, Red	1	F042		3/8-16 x 2-1/4 Hex Bolt	2
25	5989-9	Dome Plug (1/4)	8	F050		1/4 SAE Washer	1
26	8100-6	Front Body / MTL	1	F051		3/8 SAE Washer	2
	8100-7	Front Body / MTLEFI	1	F059		3/8 Wave Spring Washer	2
27	5180	Edge Molding, Lever Opening	2	F091		5/16-18 x 5/8 Hex Bolt	4
28	5989-55	Dome Plug (1/2)	1	F093		5/16-18 x 1 Hex Bolt	1
29	5989-5	Dome Plug (7/16)	1	F151		3/8-16 x 7/8 Hex Bolt	2
Tilt-Up Latch Assembly***					F157	1/2-20 x 1-1/4 Wheel Lug Bolt	8
30	5847	Plastic Tip	1	F191		3/8 x 1-1/2 x 3/16 Washer	2
31	5744-20	Spring Arm, Tilt-Up Latch	1	F205		5/16-18 x 1/4 Set Screw, Knurl Point	2
32	5744-10	Spring Pivot Bushing	1	F206		#2 x 3/16 Drive Pin	2
33	5744-15	Compression Spring (3/8 x 5/8)	1	F218		7/16 Split Lock Washer	2
34	5744-13	Mount Angle, LH	1	F219		7/16-14 x 1-1/4 Hex Bolt	2
35	5744-12	Hook, Tilt-Up Latch	1	F241		.375 x .875 x .10 Washer	4
36	5744-14	Mount Angle, RH	1	F341		Coil Roll Pin (7/64 x 9/16)	1
Chassis Assembly					F342	5/16 Conical Washer	2
37	5267-1	Retainer Collar (1")	1	F413		5/16-24 x 5/16 Set Screw	2
		(Includes Item # F413)		F429		5/16-18 x 1/2 SFH Screw	4
38	5270-1	Pivot Bearing	2	* Rear Bumper Assembly for SD Models is not shown here. Refer to BODY ASSEMBLY (SD MODELS) MTL/MTLEFI , Page 14. ** Service Part Only *** Complete Tilt-Up Latch Assembly Kit available by ordering kit # 5747.			
39	5842-1	Washer, Axle Spacer	1				
40	7420	Tail Wheel Fork	1				
41	5830-3	Grease Fitting (45 Degree)	2				
42	8039	Nut, Tail Wheel Axle	2				
43	8037-1	Seal, Outer (1-3/4 x 1-1/8)	2				
44	8038-1	Spacer, Tail Wheel Axle	2				
45	8037	Bearing Cone (3/4 ID)	4				

Use only genuine Walker® replacement parts.

Effective Date 04-01-07

BODY / CHASSIS ASSEMBLY (GHS MODELS) MTL/MTLEFI

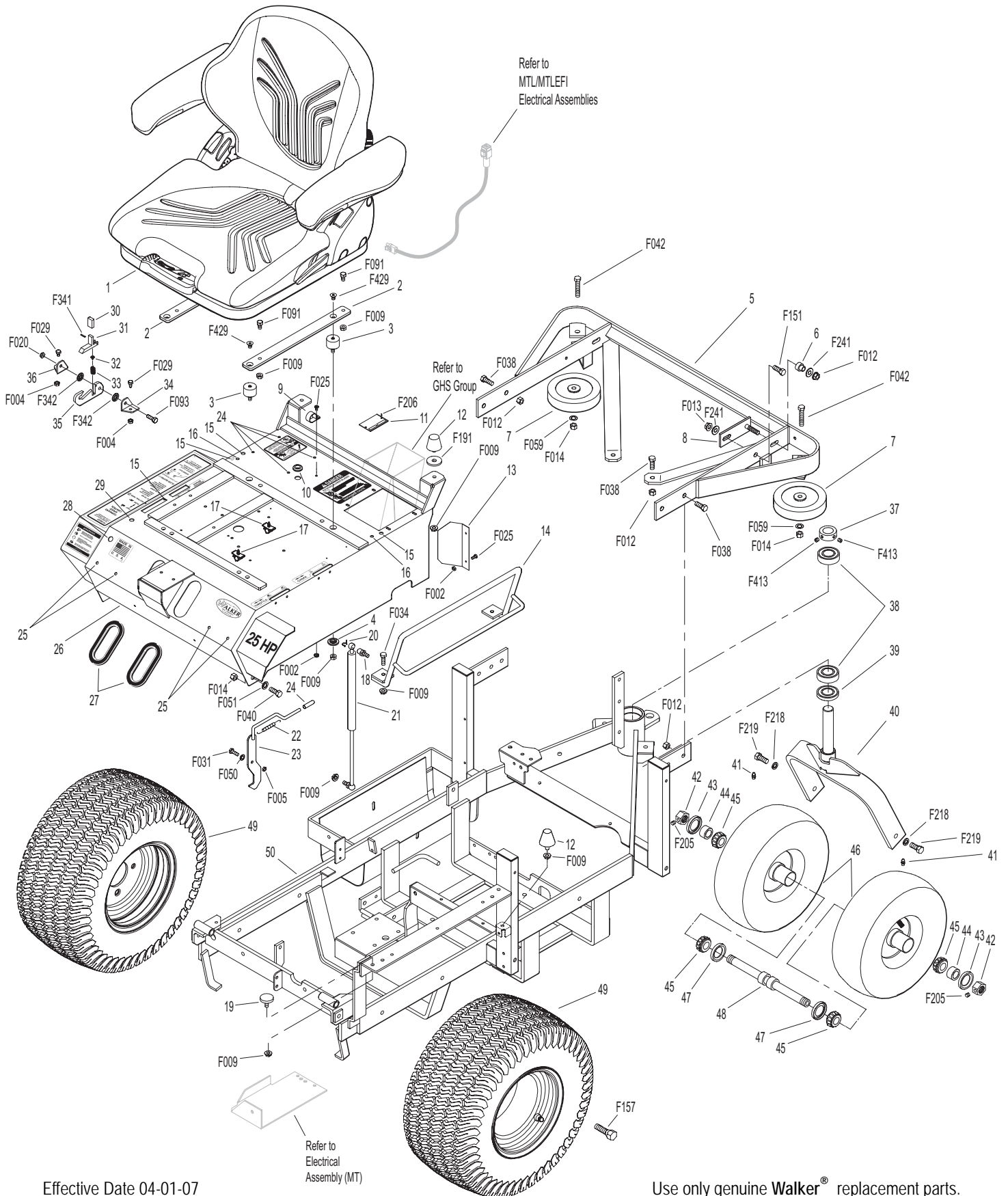

Effective Date 04-01-07

Use only genuine Walker® replacement parts.

REAR BODY ASSEMBLY (GHS MODELS) MT/MTEFI

ITEM NO.	PART NO.	DESCRIPTION	NO. REQ'D	ITEM NO.	PART NO.	DESCRIPTION	NO. REQ'D
Rear Body Assembly (GHS Models)				Fasteners			
1	7190-3	Insulation Foam Pad (5 x 20)	1	F002		10-24 Keps Nut	14
2	8082	Heat Shield	1	F004		1/4-20 Keps Nut	5
3	8515-10	Catcher Reinforcing Plate	2	F009		5/16-18 Whiz Locknut	2
4	8515-3	Catcher Support Frame	1	F025		10-24 x 3/8 PPHMS	8
5	7190-2	Insulation Foam Pad, RH	1	F026		10-24 x 1/2 PPHMS	5
6	7190-1	Insulation Foam Pad, LH	1	F027		10-24 x 5/8 PPHMS	1
7	5832	Cable Clamp (1/2)	1	F031		1/4-20 x 5/8 Hex Bolt	2
8	7145	Gas Spring Assembly (Includes Items # 10 & 11)	1	F032		1/4-20 x 3/4 Hex Bolt	1
9	8389-2	Splash Guard with Mat	1	F085		3/16 Rivet Backup Washer	2
10	7147	Spring Clip	2	F178		1/4 x 1 Fender Washer	1
11	7146	13mm Ball Stud	2	F390		1/4-20 x 7/8 Carriage Bolt	2
12	8389-12	Rubber Mat (3 x 3)	1	NOTE: Rear Bumper Assembly for GHS Models is not shown here. Refer to BODY / CHASSIS ASSEMBLY (GHS MODELS) MT/MTEFI , Page 4.			
13	8105-1	Rear Body Panel	1				

REAR BODY ASSEMBLY (GHS MODELS) MT/MTEFI

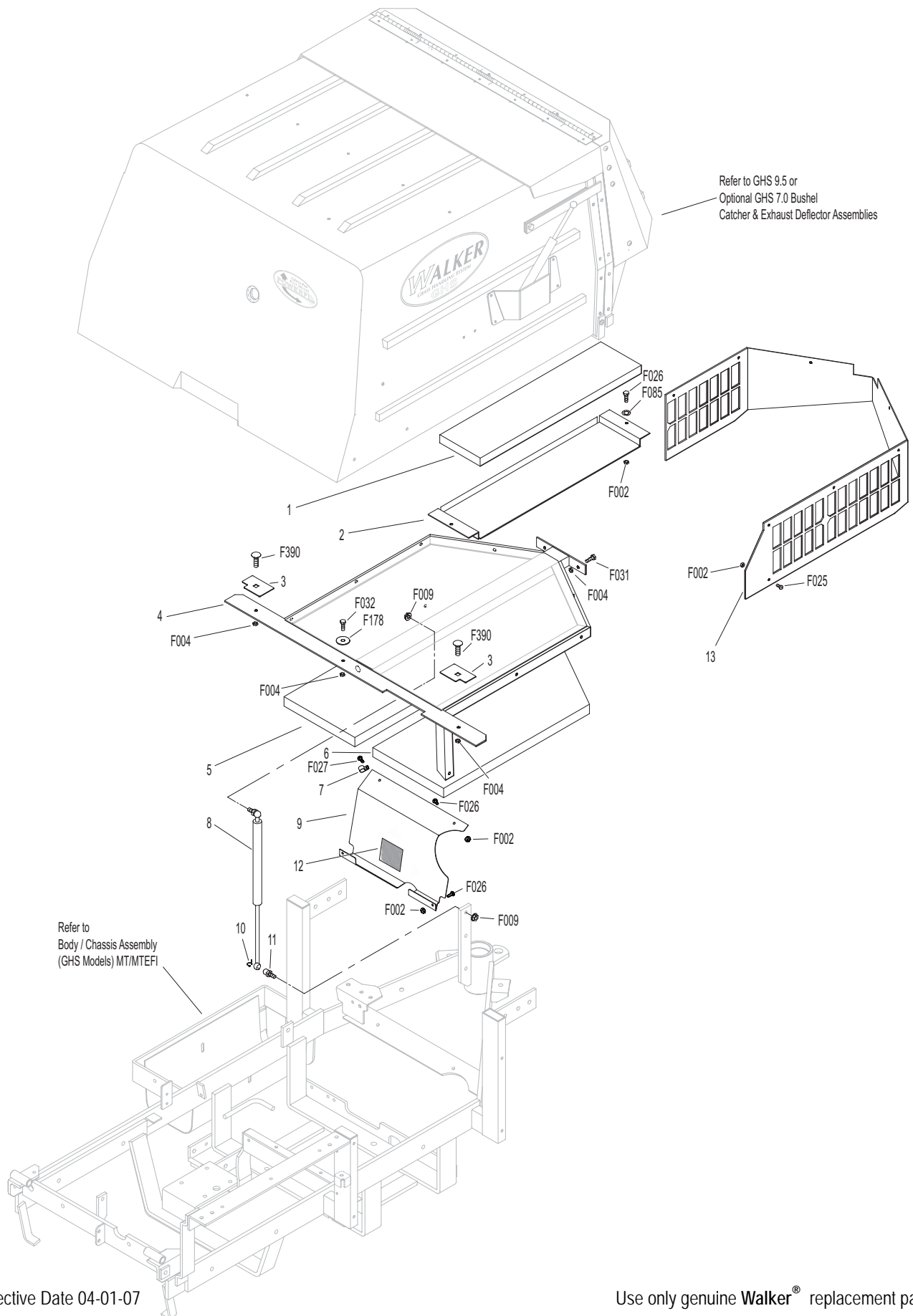

Effective Date 04-01-07

Use only genuine Walker® replacement parts.

REAR BODY ASSEMBLY (GHS MODELS) MTL/MTLEFI

ITEM NO.	PART NO.	DESCRIPTION	NO. REQ'D	ITEM NO.	PART NO.	DESCRIPTION	NO. REQ'D
Rear Body Assembly (GHS Models)				Fasteners			
1	8515-10	Catcher Reinforcing Plate	2	F002		10-24 Keps Nut	12
2	8515-4	Catcher Support Frame	1	F004		1/4-20 Keps Nut	5
3	7190-2	Insulation Foam Pad, RH	1	F009		5/16-18 Whiz Locknut	2
4	7190-1	Insulation Foam Pad, LH	1	F025		10-24 x 3/8 PPHMS	5
5	5832	Cable Clamp (1/2)	1	F026		10-24 x 1/2 PPHMS	6
6	7145	Gas Spring Assembly (Includes Items # 8 & 9)	1	F027		10-24 x 5/8 PPHMS	1
7	8389-3	Splash Guard	1	F031		1/4-20 x 5/8 Hex Bolt	2
8	7147	Spring Clip	2	F032		1/4-20 x 3/4 Hex Bolt	1
9	7146	13mm Ball Stud	2	F085		3/16 Rivet Backup Washer	3
10	8082-1	Heat Shield	1	F178		1/4 x 1 Fender Washer	1
11	7190-4	Insulation Foam Pad/GHS	1	F390		1/4-20 x 7/8 Carriage Bolt	2
12	8105-16	Rear Body Panel	1				

NOTE: Rear Bumper Assembly for GHS Models is not shown here. Refer to **BODY / CHASSIS ASSEMBLY (GHS MODELS) MTL/MTLEFI**, Page 6.

REAR BODY ASSEMBLY (GHS MODELS) MTL/MTLEFI

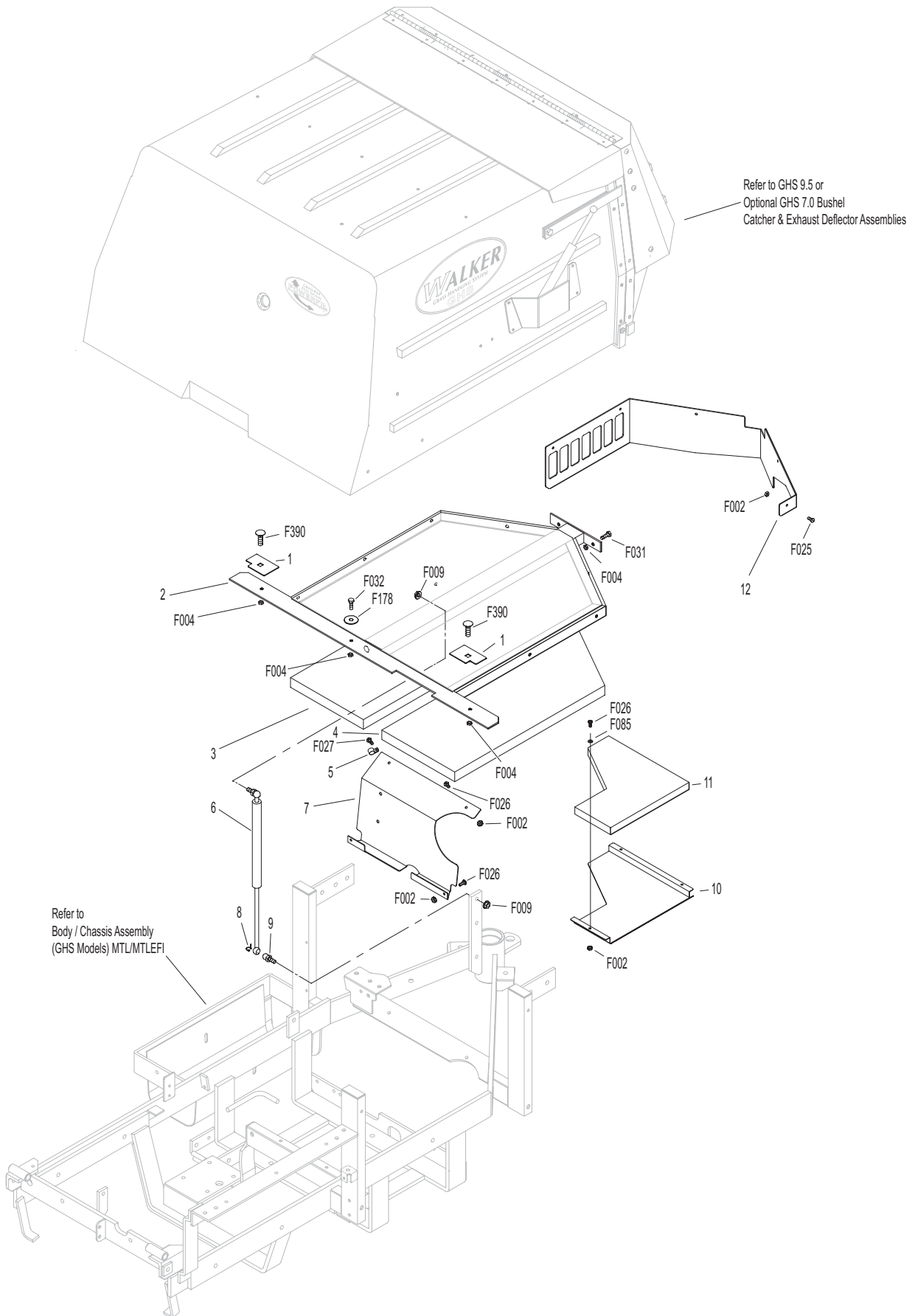

BODY ASSEMBLY (SD MODELS) MT/MTEFI

ITEM NO.	PART NO.	DESCRIPTION	NO. REQ'D	ITEM NO.	PART NO.	DESCRIPTION	NO. REQ'D
Utility Bed Assembly				Fasteners			
1	8650-10	Bed Liner (21.5 x 27.5)	1	F002		10-24 Keps Nut	16
2	8650-2	Utility Bed (Includes Item # 1)	1	F009		5/16-18 Whiz Locknut	2
3	7190-2	Insulation Foam Pad, RH	1	F012		3/8-16 Keps Nut	6
4	7190-1	Insulation Foam Pad, LH	1	F013		3/8-16 Whiz Locknut	4
Rear Bumper Assembly (SD Models)				F014		3/8-16 ESNA Nut	2
5	7153-3	Cover Plate	1	F025		10-24 x 3/8 PPHMS	8
6	7145	Gas Spring Assembly (Includes Items # 7 & 8)	1	F026		10-24 x 1/2 PPHMS	3
7	7147	Spring Clip	2	F027		10-24 x 5/8 PPHMS	1
8	7146	13mm Ball Stud	2	F038		3/8-16 x 1 Hex Bolt	6
9	7521	Rear Bumper	1	F040		3/8-16 x 1-1/2 Hex Bolt	2
10	5162	Roller Wheel (5" Rubber)	2	F042		3/8-16 x 2-1/4 Hex Bolt	2
11	8105-1	Rear Body Panel	1	F051		3/8 SAE Washer	4
12	8389-2	Splash Guard with Mat	1	F059		3/8 Wave Spring Washer	2
13	8389-12	Rubber Mat (3 x 3)	1	F128		10-24 x 3/8 PTHMS	4

NOTE: Refer to **BODY / CHASSIS ASSEMBLY (GHS MODELS) MT/MTEFI**, Page 4 for all common parts used on both models.

BODY ASSEMBLY (SD MODELS) MT/MTEFI

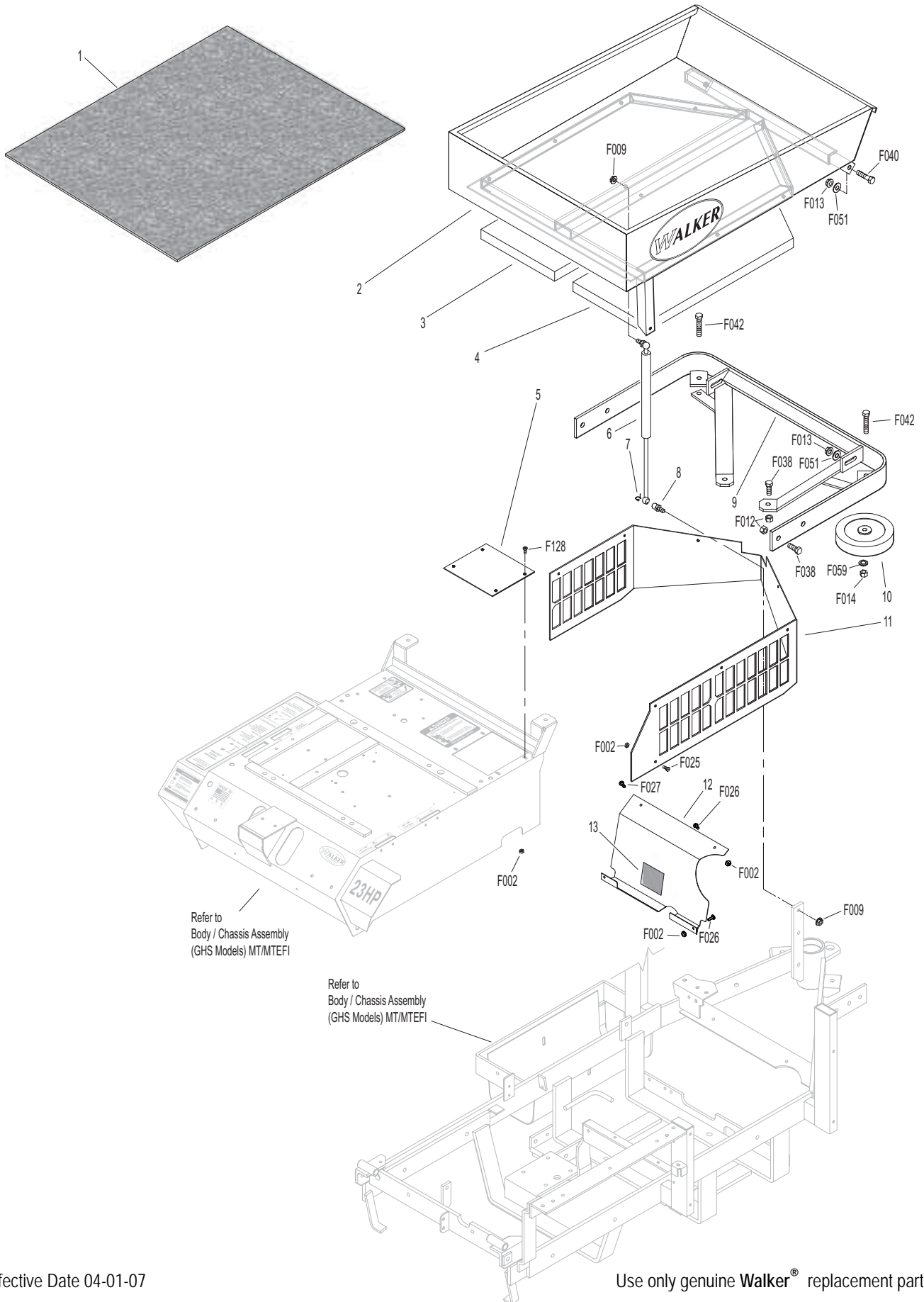

Effective Date 04-01-07

Use only genuine Walker® replacement parts.

BODY ASSEMBLY (SD MODELS) MTL/MTLEFI

ITEM NO.	PART NO.	DESCRIPTION	NO. REQ'D	ITEM NO.	PART NO.	DESCRIPTION	NO. REQ'D
Utility Bed Assembly				Fasteners			
1	8650-10	Bed Liner (21.5 x 27.5)	1	F002		10-24 Keps Nut	13
2	8650-3	Utility Bed (Includes Item # 1)	1	F009		5/16-18 Whiz Locknut	2
3	7190-2	Insulation Foam Pad, RH	1	F012		3/8-16 Keps Nut	6
4	7190-1	Insulation Foam Pad, LH	1	F013		3/8-16 Whiz Locknut	4
Rear Bumper Assembly (SD Models)				F014		3/8-16 ESNA Nut	2
5	7153-3	Cover Plate	1	F025		10-24 x 3/8 PPHMS	5
6	7145	Gas Spring Assembly (Includes Items # 7 & 8)	1	F026		10-24 x 1/2 PPHMS	3
7	7147	Spring Clip	2	F027		10-24 x 5/8 PPHMS	1
8	7146	13mm Ball Stud	2	F038		3/8-16 x 1 Hex Bolt	6
9	7521-5	Rear Bumper	1	F040		3/8-16 x 1-1/2 Hex Bolt	2
10	5162	Roller Wheel (5" Rubber)	2	F042		3/8-16 x 2-1/4 Hex Bolt	2
11	8105-16	Rear Body Panel	1	F051		3/8 SAE Washer	4
12	8389-3	Splash Guard	1	F059		3/8 Wave Spring Washer	2
				F128		10-24 x 3/8 PTHMS	4

NOTE: Refer to **BODY / CHASSIS ASSEMBLY (GHS MODELS) MTL/MTLEFI**, Page 6 for all common parts used on both models.

BODY ASSEMBLY (SD MODELS) MTL/MTLEFI

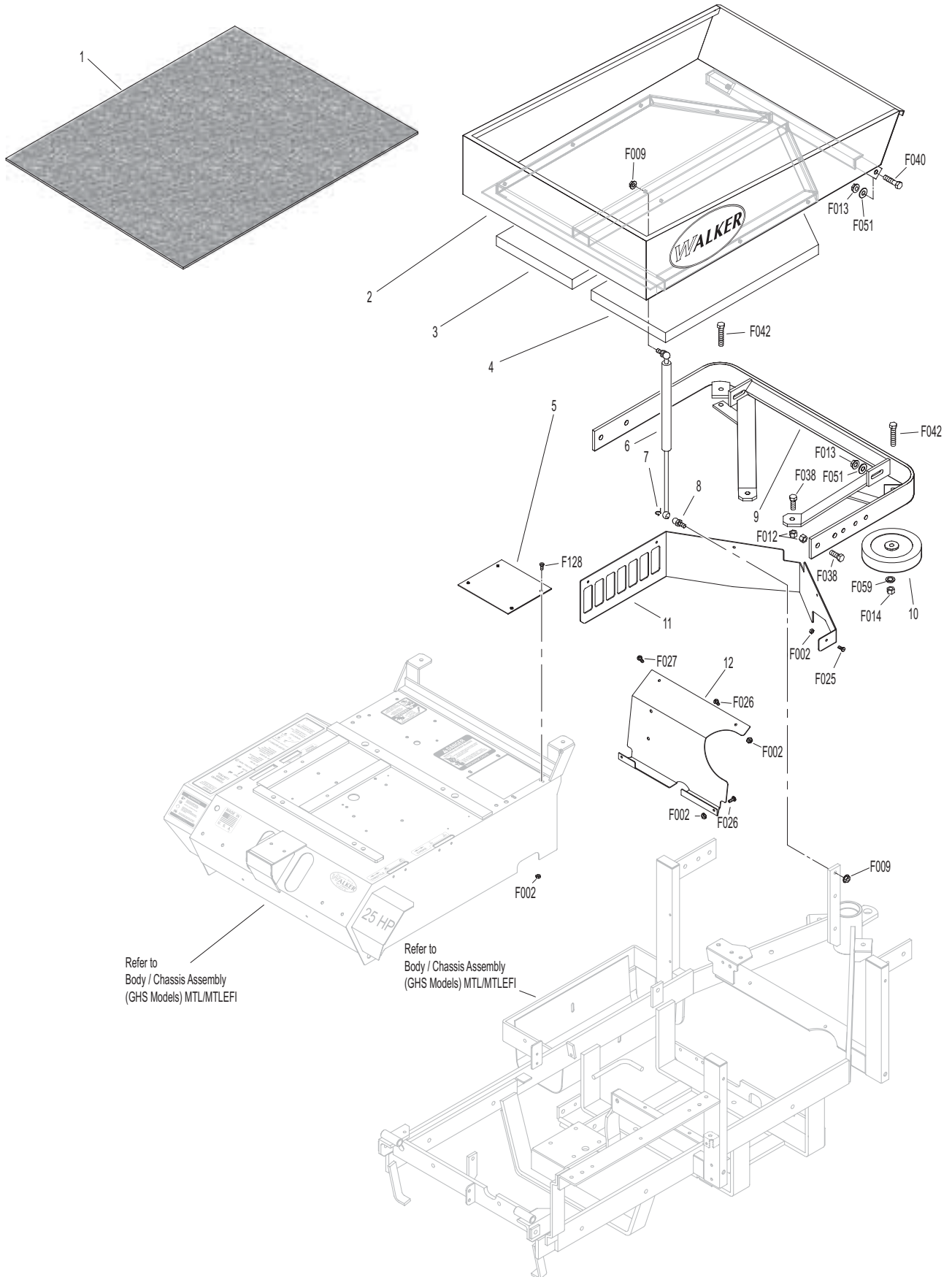

MAIN COMPONENT POWER TRANSMISSION (GHS MODELS)

ITEM NO.	PART NO.	DESCRIPTION	NO. REQ'D	ITEM NO.	PART NO.	DESCRIPTION	NO. REQ'D
Clutch Lever Assembly				45	8539	Starter Relay Mount	1
1	8358-3	Clutch Lever (Includes Items # 2 & 3)	1	46	5268	Bearing W/Collar (3/4)	2
2	5830	Grease Fitting	7	47	7241-2	Transmission Drive Pulley (3-1/4/MV) (Includes Items # F067 & F171)	1
3	7860	Handle Grip	1	48	7833	Cable Clamp (7/8 x 1/4)	1
4	7303-10	Clutch Actuator Bolt (3/8)	1	49	8349	Transmission Belt Tightener Arm	1
5	7380-5	Knuckle Joint (3/8 ID)	1	50	8394-1	Hydro Jackshaft Mount Assembly (Includes Items # 2, 9, 43, 46, 50 & 51)	*
6	7226-10	Compression Spring (3/4 x 2-1/2)	1	51	8273	Jackshaft (3/4 x 7-1/2)	1
7	8130-5	Pushrod, Clutch Actuator (Threaded Tube)	1	52	7240-3	Jackshaft Drive Pulley (4.15/3V) (Includes Items # F067 & F171)	1
8	8130-10	Clutch Actuator Rod Assembly (Includes Items # 2, 4-7, F054, F336 & F353)	1	53	7240-4	Jackshaft Drive Pulley (3.3/3V) (Includes Items # F067 & F171)	1**
9	7201-3	DU Bearing	6	54	8349-3	Idler Arm, MTLEFI	1***
10	7201-5	Inner Race (2-1/4)	1	Fasteners			
11	8368	PTO Belt Tightener	1	F003	1/4-28 Hex Nut	2	
12	5841	Retainer Washer (3/8 x 1-1/4)	4	F004	1/4-20 Keps Nut	3	
13	8243	Clutch Idler Pulley Assembly (Includes Items # 14, 15 & F070)	1	F005	1/4-20 ESNA Nut	1	
	8243-1	Clutch Idler Pulley	1	F009	5/16-18 Whiz Locknut	3	
14	5265	Bearing (3/4)	1	F012	3/8-16 Keps Nut	8	
15	8243-3	Hub, Idler Pulley	1	F029	1/4-20 x 1/2 Hex Bolt	1	
16	8375	PTO Belt Tightener Stop	1	F040	3/8-16 x 1-1/2 Hex Bolt	1	
17	7377	Plastic Washer (1 x .438 x .025)	2	F041	3/8-16 x 1-3/4 Hex Bolt	2	
18	7378	Pivot Bearing (7/16 x 9/16)	1	F042	3/8-16 x 2-1/4 Hex Bolt	3	
19	5281-1	Clevis Spring Pin	1	F043	3/8-16 x 3 Hex Bolt	1	
20	5280	Clevis (1/4)	2	F047	3/8-16 x 4-1/2 Hex Bolt	1	
21	8305	Brake Actuator Rod	1	F054	AN960616 Washer	3	
22	8370	Bearing, Brake Actuator	1	F061	1/4 Internal Star Lock Washer	1	
23	5281-5	Clevis Pin (1/4 x 0.80)	1	F067	3/16 x 3/16 x 1 Key	2	
24	8250	Brake Spring (1/2 x 2-1/2)	1	F069	3/32 x 1/2 Cotter Pin	1	
25	8369	Brake Actuator (Includes Items # 2 & 22)	1	F070	1-3/4 Internal Snap Ring	1	
PTO Drive Shaft Assembly				F090	1/4-20 x 2-1/2 Hex Bolt	1	
26	7050-1	Dipstick, Gearbox	1	F116	1/4-20 x 1-1/4 Hex Bolt	1	
27	8371-1	Mount Bracket, Brake Band	1	F121	5/16-18 x 3/8 x 1 SHL Bolt	1	
28	8377	Brake Band Guide	1	F131	5/16-18 x 1/2 Hex Bolt	2	
29	8050-11	PTO Gearbox / Flange Pulley	1	F132	1/4-20 x 2-3/4 Hex Bolt	1	
30	5245	Idler Pulley (3")	2	F168	5/16 Split Lock Washer	13	
31	7248	Ground Drive Belt, Micro-V	1	F171	5/16-18 x 3/8 Set Screw	4	
32	7275-16	Universal Joint Tube Assembly/Spline	1	F178	1/4 x 1 Fender Washer	1	
33	7275-9	Quick Coupler Installation Tool	1	F182	1/4 x 5/8 x 1/8 Washer	2	
34	7523-2	Clevis Pin w/Hole (1/4 x 5/8)	1	F186	5/64 x 1/2 Cotter Pin	1	
35	8304	Brake Band (14-1/2)	1	F226	5/16-18 x 7/8 Hex Bolt	13	
36	6250	Drive Belt (3VX375)	1	F241	.375 x .875 x .10 Washer	1	
37	7236-1	PTO Drive Pulley (4-1/2/3V) (Includes Items # F168 & F226)	1	F255	5/16-18 x 1-1/2 Hex Bolt	2	
38	8237-2	Engine Pulley, Bolt On (4/3.8/3V) (Includes Items # F168 & F226)	1	F261	AN960616L Washer	1	
39	8230	Engine PTO Belt	1	F336	3/8-16 Jam Nut	1	
Jackshaft Assembly				F353	3/8-16 ESNA LP Nut	1	
40	7245-1	Idler Pulley (3/8 Groove)	1	* Service Part Only			
41	6325-2	Spacer Bushing (5/16)	2	** Item used on MTL and MTLEFI only			
42	8349-2	Idler Arm	1	*** Item used on MTLEFI only			
43	7201-4	Inner Race (1-1/2)	2				
44	5221	Extension Spring (3/4 x 4)	2				

Use only genuine Walker® replacement parts.

Effective Date 04-01-07

MAIN COMPONENT POWER TRANSMISSION (SD MODELS)

ITEM NO.	PART NO.	DESCRIPTION	NO. REQ'D	ITEM NO.	PART NO.	DESCRIPTION	NO. REQ'D	
Clutch Lever Assembly				45	8539	Starter Relay Mount	1	
1	8358-3	Clutch Lever (Includes Items # 2 & 3)	1	46	5268	Bearing W/Collar (3/4)	2	
2	5830	Grease Fitting	7	47	7241-2	Transmission Drive Pulley (3-1/4/MV) (Includes Items # F067 & F171)	1	
3	7860	Handle Grip	1	48	7833	Cable Clamp (7/8 x 1/4)	1	
4	7303-10	Clutch Actuator Bolt (3/8)	1	49	7394-6	Idler Pulley Spring Mount	1 ^Δ	
5	7380-5	Knuckle Joint (3/8 ID)	1	50	8349	Transmission Belt Tightener Arm	1	
6	7226-10	Compression Spring (3/4 x 2-1/2)	1	51	8393-7	Hydro Jackshaft Mount	1	
7	8130-5	Pushrod, Clutch Actuator (Threaded Tube)	1		8394-1	Hydro Jackshaft Mount Assembly (Includes Items # 2, 9, 43, 46, 51 & 52)	*	
8	8130-10	Clutch Actuator Rod Assembly (Includes Items # 2, 4-7, F054, F336 & F353)	1	52	8273	Jackshaft (3/4 x 7-1/2)	1	
9	7201-3	DU Bearing	6	53	7240-3	Jackshaft Drive Pulley (Includes Items # F067 & F171)	1	
10	7201-5	Inner Race (2-1/4)	1	54	7240-4	Jackshaft Drive Pulley (3.3/3V) (Includes Items # F067 & F171)	1**	
11	8368	PTO Belt Tightener	1	55	8349-3	Idler Arm, MTLEFI	1***	
12	5841	Retainer Washer (3/8 x 1-1/4)	4	Fasteners				
13	8243	Clutch Idler Pulley Assembly (Includes Items # 14, 15 & F070)	1		F003	1/4-28 Hex Nut	2	
	8243-1	Clutch Idler Pulley	1		F004	1/4-20 Keps Nut	3	
14	5265	Bearing (3/4)	1		F005	1/4-20 ESNA Nut	1	
15	8243-3	Hub, Idler Pulley	1		F009	5/16-18 Whiz Locknut	3	
16	8375	PTO Belt Tightener Stop	1		F012	3/8-16 Keps Nut	8	
17	7377	Plastic Washer (1 x .438 x .025)	2		F029	1/4-20 x 1/2 Hex Bolt	1	
18	7378	Pivot Bearing (7/16 x 9/16)	1		F040	3/8-16 x 1-1/2 Hex Bolt	1	
19	5281-1	Clevis Spring Pin	1		F041	3/8-16 x 1-3/4 Hex Bolt	2	
20	5280	Clevis (1/4)	2		F042	3/8-16 x 2-1/4 Hex Bolt	3	
21	8305	Brake Actuator Rod	1		F043	3/8-16 x 3 Hex Bolt	1	
22	8370	Bearing, Brake Actuator	1		F047	3/8-16 x 4-1/2 Hex Bolt	1	
23	5281-5	Clevis Pin (1/4 x 0.80)	1		F054	AN960616 Washer	3	
24	8250	Brake Spring (1/2 x 2-1/2)	1		F061	1/4 Internal Star Lock Washer	1	
25	8369	Brake Actuator (Includes Items # 2 & 22)	1		F067	3/16 x 3/16 x 1 Key	2	
PTO Drive Shaft Assembly						F069	3/32 x 1/2 Cotter Pin	2
26	7050-1	Dipstick, Gearbox	1		F070	1-3/4 Internal Snap Ring	1	
27	8371-1	Mount Bracket, Brake Band	1		F090	1/4-20 x 2-1/2 Hex Bolt	2	
28	8377	Brake Band Guide	1		F116	1/4-20 x 1-1/4 Hex Bolt	1	
29	8050-11	PTO Gearbox / Flange Pulley	1		F121	5/16-18 x 3/8 x 1 SHL Bolt	1	
30	5245	Idler Pulley (3")	2		F131	5/16-18 x 1/2 Hex Bolt	2	
31	7248	Ground Drive Belt, Micro-V	1		F168	5/16 Split Lock Washer	13	
32	7275-16	Universal Joint Tube Assembly/Spine	1		F171	5/16-18 x 3/8 Set Screw	4	
33	7275-9	Quick Coupler Installation Tool	1		F178	1/4 x 1 Fender Washer	1	
34	7523-2	Clevis Pin w/Hole (1/4 x 5/8)	1		F182	1/4 x 5/8 x 1/8 Washer	2	
35	8304	Brake Band (14-1/2)	1		F186	5/64 x 1/2 Cotter Pin	1	
36	6250	Drive Belt (3VX375)	1		F226	5/16-18 x 7/8 Hex Bolt	13	
37	7236-1	PTO Drive Pulley (4-1/2/3V) (Includes Items # F168 & F226)	1		F241	.375 x .875 x .10 Washer	1	
38	8237-2	Engine Pulley, Bolt On (4/3.8/3V) (Includes Items # F168 & F226)	1		F255	5/16-18 x 1-1/2 Hex Bolt	2	
39	8230	Engine PTO Belt	1		F261	AN960616L Washer	1	
Jackshaft Assembly						F336	3/8-16 Jam Nut	1
40	7245-1	Idler Pulley (3/8 Groove)	1		F353	3/8-16 ESNA LP Nut	1	
41	6325-2	Spacer Bushing (5/16)	2	*		Service Part Only		
42	8349-2	Idler Arm	1	**		Item used on MTL and MTLEFI only		
43	7201-4	Inner Race (1-1/2)	2	***		Item used on MTLEFI only		
44	5221	Extension Spring (3/4 x 4)	2	Δ		Item used on MT only		

Use only genuine Walker[®] replacement parts.

Effective Date 04-01-07

ENGINE GROUP (MT)

ITEM NO.	PART NO.	DESCRIPTION	NO. REQ'D	ITEM NO.	PART NO.	DESCRIPTION	NO. REQ'D
Precleaner Assembly				Exhaust Assembly			
1	7026-2	Remote Precleaner (Includes Item # 5)	1	38	8530-8	Muffler Grass Shield (Includes Items # F002 & F025)	1
2	7440	Shock Mount (1.0 OD x .75)	3	39	NS	Screw (Kohler M-645016-S)	2
3	7028-20	Rear Precleaner Mount	1	40	NS	Gasket (Kohler)	2
4	7027	Elbow, Precleaner	1	41	NS	Nut (Kohler)	4
5	7840	Hose Clamp (1-5/16 to 2-1/4)	4	42	8013-9	Muffler	1
6	5088-12	Air Cleaner Assembly (Includes Items # 8-12 & 14)	*	43	8013-2	Upright Support	1
7	5088-1	Air Cleaner Band	1	44	8013-13	Muffler Heat Shield	1
8	5090-3	Safety Filter Insert	1	45	8013-18	Muffler Brace	1
9	5090-1	Air Cleaner Cartridge	1	46	8021	Engine Brace	1
10	5088-5	Air Cleaner Draw Latch	2	47	8013-29	Muffler Heat Shield Endcap	1
11	5088-11	Air Cleaner Cap (Includes Item # 10)	1	48	8013-61	Muffler Heat Deflector W/Knurl Inserts	1
12	5090-2	Vacuator Valve	1	Fasteners			
13	8026-10	Air Hose, Cleaner	1		F002	10-24 Keps Nut	2
14	5091-11	Air Flow Indicator & Nipple	1		F004	1/4-20 Keps Nut	4
15	7031	Tube Support Arm	1		F009	5/16-18 Whiz Locknut	14
16	7028-3	Precleaner Tube, SD	1		F012	3/8-16 Keps Nut	1
17	7028-2	Precleaner Tube, GHS	1		F025	10-24 x 3/8 PPHMS	2
18	6029	Hose Clamp (2-1/2)	1		F026	10-24 x 1/2 PPHMS	3
Engine Assembly					F029	1/4-20 x 1/2 Hex Bolt	4
19	NS	23-hp Engine	1		F031	1/4-20 x 5/8 Hex Bolt	1
20	NS	Fuel Pump (Kohler)	1		F038	3/8-16 x 1 Hex Bolt	2
21	5879-3	Hose Clamp (1/2)	4		F050	1/4 SAE Washer	4
22	NS	Fuel Line, Engine (Kohler)	*		F052	5/16 External Star Lock Washer	2
23	5020	Fuel Filter	*		F053	7/16 Int. Star Lock Washer	2
24	NS	Oil Filter (Kohler 1205001)	1		F061	1/4 Internal Star Lock Washer	4
25	8010-6	Valve Cover Sleeve	2		F063	3/8 Internal Star Lock Washer	2
26	5845	Bumper, Rubber (1.50 OD x 1.25)	1		F079	A/A66D Aluminum Pop Rivet	2
27	8010-2	Engine Bumper Mount	1		F090	1/4-20 x 2-1/2 Hex Bolt	1
28	5832	Cable Clamp (1/2)	3		F091	5/16-18 x 5/8 Hex Bolt	2
Fuel Tank Assembly					F106	3/8-16 x 5/8 Hex Bolt	2
29	8015-3	Fuel Line, Tank (1/4 x 24-1/2)	1		F120	AN960416 Washer	2
30	5083-1	Bushing, Rubber	*		F129	10-24 x 1/2 PTHMS	1
31	5086-7	Hose (3/8 x 6)	1		F132	1/4-20 x 2-3/4 Hex Bolt	1
32	8023	Fuel Tank Support	1		F140	7/16-14 x 1 Hex Bolt	2
33	5020-2	Fuel Filter, In Tank	1		F175	1/2 Split Lock Washer	4
34	8046-9	Fuel Tank, 5 Gallon, Gas (Includes Items # 35 & 36)	1		F255	5/16-18 x 1-1/2 Hex Bolt	2
35	5082-2	Fuel Cap Seal	*		F256	7/16 SAE Washer	2
36	5082	Fuel Tank Cap (Includes Item # 35)	*		F273	M6 x 1.0 Nut	4
37	5083-5	Tank Tube Elbow	1		F274	M6 x 1.0 x 45 Stud	2
					F285	1/2-13 x 1-1/2 Hex Bolt	4
					F324	M8 x 1.25 x 12 Hex Bolt	2

* Service Part Only

NOTE: Item 16 is used only on SD Models. Item 17 is used only on GHS Models. Both items use existing fasteners at clutch lever.

NOTE: Refer to Kohler Engine Decal (NS) for Engine Identification Numbers.

Use only genuine Walker® replacement parts.

Effective Date 04-01-07

ENGINE GROUP (MTL)

ITEM NO.	PART NO.	DESCRIPTION	NO. REQ'D	ITEM NO.	PART NO.	DESCRIPTION	NO. REQ'D
Fuel Tank Assembly				Engine Assembly			
1	5083-5	Tank Tube Elbow	1	23	NS	Regulator (Kohler)	1
2	5879-3	Hose Clamp (1/2)	4	24	NS	Oil Filter (Kohler 1205001)	1
3	8015-3	Hose (1/4 x 24-1/2)	1	25	7958-2	Resistor Mount Plate	1
4	NS	Fuel Pump (Kohler)	1	26	5841	Retainer Washer (3/8 x 1-1/4)	2
5	NS	Fuel Line (Kohler)	1	27	NS	25-hp Engine	1
6	5020	Fuel Filter	*	28	7306-12	Temperature Sender Adapter	1
7	5832	Cable Clamp (1/2) (Uses Existing Fasteners at Engine)	2	29	7306-15	Water Temperature Sender	1
8	5083-1	Bushing, Rubber	*	Fasteners			
9	5086-7	Hose (3/8 x 6)	1	F002	10-24 Keps Nut		2
10	5020-2	Fuel Filter, In Tank	1	F004	1/4-20 Keps Nut		2
11	8046-9	Fuel Tank, 5 Gallon, Gas (Includes Items # 12 & 13)	1	F009	5/16-18 Whiz Locknut		2
12	5082-2	Fuel Cap Seal	*	F012	3/8-16 Keps Nut		5
13	5082	Fuel Tank Cap (Includes Item # 12)	*	F025	10-24 x 3/8 PPHMS		2
Exhaust Assembly				F029	1/4-20 x 1/2 Hex Bolt		2
14	5665	Compression Spring (1/2 x 1)	2	F031	1/4-20 x 5/8 Hex Bolt		1
15	8530-15	Muffler End Shield	1	F032	1/4-20 x 3/4 Hex Bolt		1
16	8530-17	Upper Grass Shield	1	F038	3/8-16 x 1 Hex Bolt		1
17	8013-34	Muffler Mount Tab	1	F041	3/8-16 x 1-3/4 Hex Bolt		4
18	8013-31	Muffler	1	F050	1/4 SAE Washer		2
19	8013-32	Exhaust Pipe, Muffler	1	F051	3/8 SAE Washer		4
20	8013-16	Mounting Spring, Muffler	2	F061	1/4 Internal Star Lock Washer		2
21	NS	Nut (Kohler)	4	F063	3/8 Internal Star Lock Washer		3
22	NS	Gasket (Kohler)	2	F079	A/A66D Aluminum Pop Rivet		2
				F091	5/16-18 x 5/8 Hex Bolt		2
				F151	3/8-16 x 7/8 Hex Bolt		2
				F187	1/4-20 x 1-1/2 Hex Bolt		2
				F188	1/4-20 Self-Locking Nut		2

* Service Part Only

NOTE: Refer to Kohler Engine Decal (NS) for Engine Identification Numbers.

ENGINE GROUP (MTL)

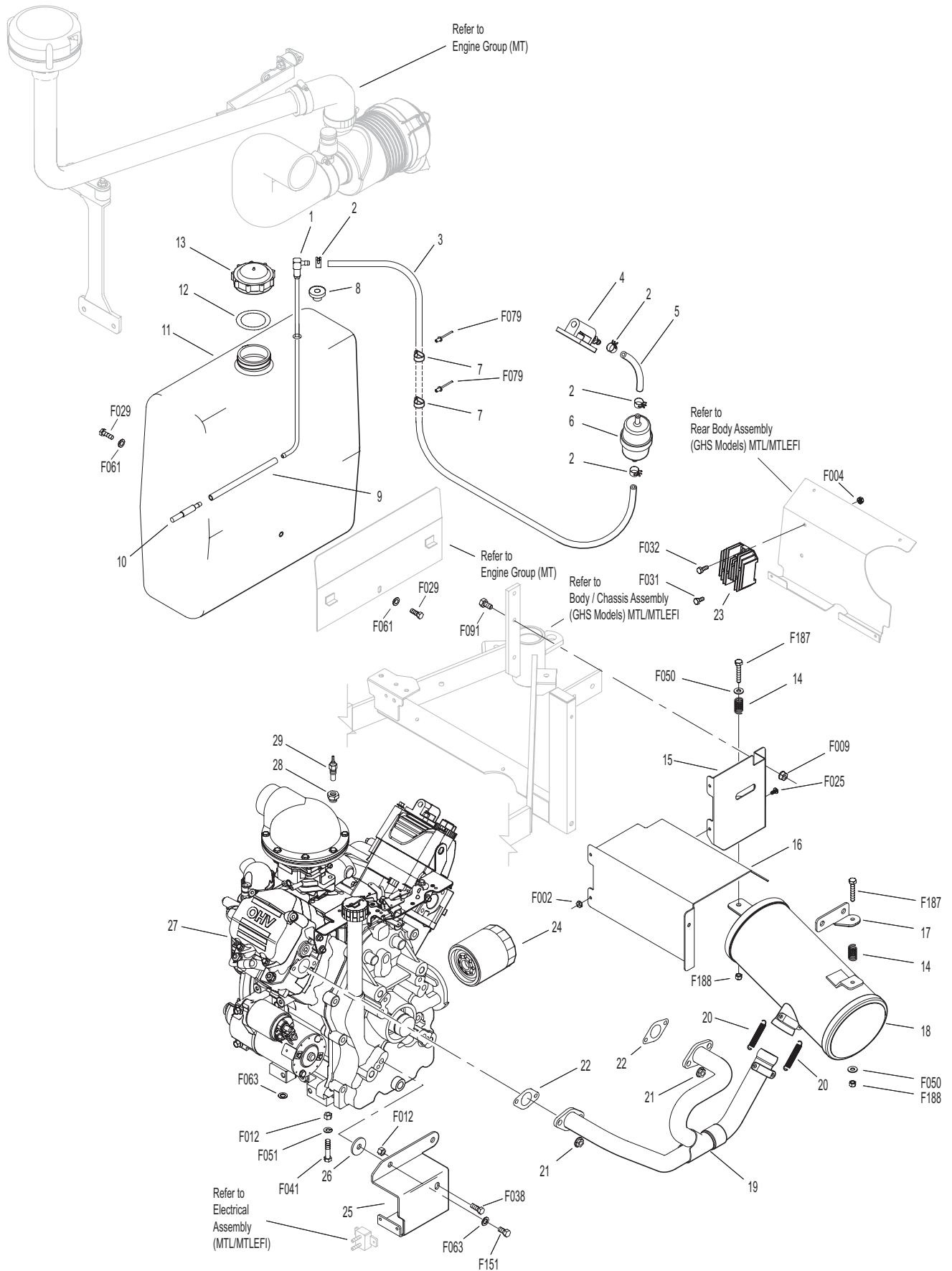

ENGINE GROUP (MTEFI)

ITEM NO.	PART NO.	DESCRIPTION	NO. REQ'D	ITEM NO.	PART NO.	DESCRIPTION	NO. REQ'D
Fuel Tank Assembly				Exhaust Assembly			
1	5083-2	Tank Tube Elbow	1	28	8530-9	Grass Shield, Muffler (EFI) (Includes Items # F002 & F025)	1
2	5879-5	Stepless Ear Clamp (5/8)	7	29	NS	Screw (Kohler M645016-S)	2
3	8026-3	Fuel Line (5/16 x 32) Tank to Pump (Includes Item # 2)	1	30	NS	Sensor, Oxygen (Kohler)	1
4	7833	Cable Clamp (7/8 x 1/4)	5	31	NS	Gasket (Kohler)	2
5	8026-5	Fuel Line (5/16 x 21) Regulator to Filter (Includes Item # 2)	1	32	NS	Nut (Kohler M-0841080)	4
6	8026-14	Clamp, Loop Style	1	33	8013-11	Muffler (EFI)	1
7	5879-3	Hose Clamp (1/2)	2	34	8013-2	Upright Support	1
8	NS	Fuel Regulator (Kohler)	1	35	8013-13	Muffler Heat Shield	1
9	NS	Fuel Filter (Kohler)	1	36	8013-18	Muffler Brace	1
10	8026-4	Fuel Line (5/16 x 8) Pump to Regulator (Includes Item # 2)	1	37	8021	Engine Brace	1
11	8026-6	Fuel Line (5/16 x 13") Filter to Engine (Includes Item # 2)	1	38	8013-29	Muffler Heat Shield Endcap	1
12	NS	Fuel Pump (Kohler)	1	39	8013-61	Muffler Heat Deflector W/Knurled Inserts	1
13	NS	Clamp (Kohler)	2	Fasteners			
14	7014-3	Fuel Pump Mount Plate	1	F002		10-24 Keps Nut	6
15	8026-8	Vent Tube, Regulator	1	F004		1/4-20 Keps Nut	8
16	7014-2	Regulator/Filter Mount	1	F012		3/8-16 Keps Nut	1
17	5832	Cable Clamp (1/2) (Uses Existing Fasteners at Engine)	3	F025		10-24 x 3/8 PPHMS	3
18	5083-1	Bushing, Rubber	*	F026		10-24 x 1/2 PPHMS	4
19	7046-1	Fuel Return Tube	1	F027		10-24 x 5/8 PPHMS	3
20	8026-7	Hose (1/4 x 16)	1	F029		1/4-20 x 1/2 Hex Bolt	6
21	5086	Hose (1/4 x 18)	1	F031		1/4-20 x 5/8 Hex Bolt	2
22	5020-2	Fuel Filter, In Tank	1	F038		3/8-16 x 1 Hex Bolt	1
23	5082	Fuel Tank Cap (Includes Item # 24)	*	F050		1/4 SAE Washer	1
24	5082-2	Fuel Cap Seal	*	F052		5/16 External Star Lock Washer	2
25	8046-7	Fuel Tank, 5 Gallon, Gas (Includes Items # 18, 23 & 24)	1	F053		7/16 Int. Star Lock Washer	2
Engine Assembly				F061		1/4 Internal Star Lock Washer	4
26	NS	Oil Filter (Kohler 1205001)	1	F063		3/8 Internal Star Lock Washer	2
27	NS	26-hp EFI Engine (78528)	1	F079		A/A66D Aluminum Pop Rivet	2
				F090		1/4-20 x 2-1/2 Hex Bolt	1
				F106		3/8-16 x 5/8 Hex Bolt	2
				F120		AN960416 Washer	2
				F129		10-24 x 1/2 PTHMS	1
				F132		1/4-20 x 2-3/4 Hex Bolt	1
				F140		7/16-14 x 1 Hex Bolt	2
				F175		1/2 Split Lock Washer	4
				F256		7/16 SAE Washer	2
				F285		1/2-13 x 1-1/2 Hex Bolt	4
				F324		M8 x 1.25 x 12 Hex Bolt	2

* Service Part Only

NOTE: Refer to Kohler Engine Decal (NS) for Engine Identification Numbers.

ENGINE GROUP (MTEFI)

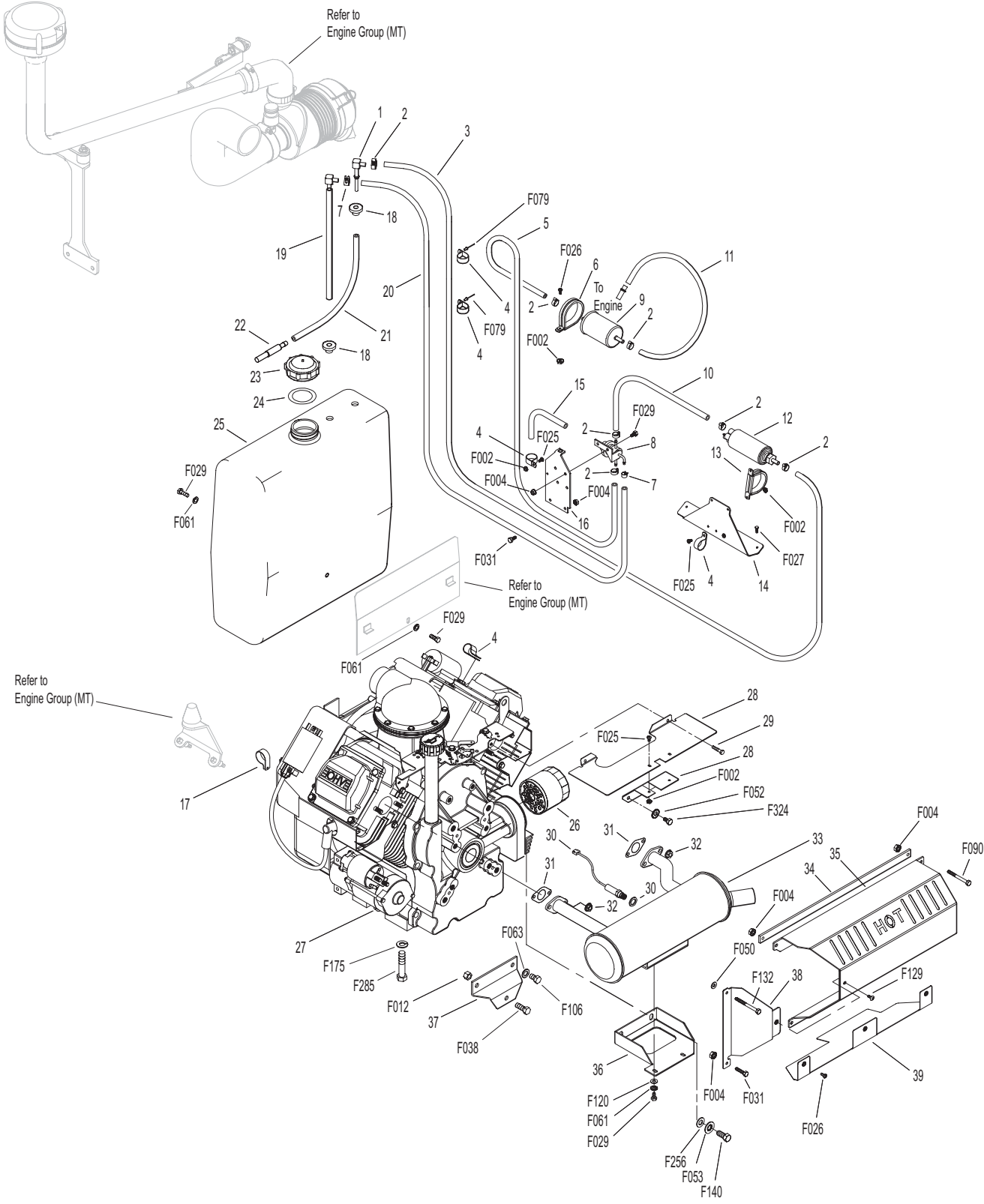

ENGINE GROUP (MTLEFI)

ITEM NO.	PART NO.	DESCRIPTION	NO. REQ'D	ITEM NO.	PART NO.	DESCRIPTION	NO. REQ'D
Fuel Tank Assembly				Engine Assembly			
1	8026-7	Hose (1/4 x 16)	1	39	NS	Regulator (Kohler)	1
2	8026-5	HP Fuel Line (5/16 x 21) Regulator To Filter (Includes Item # 3)	1	40	NS	Oil Filter (Kohler 1205001)	1
3	5879-5	Stepless Ear Clamp (5/8)	7	41	7958-2	Resistor Mount Plate	1
4	8026-14	Clamp, Loop Style	1	42	5841	Retainer Washer (3/8 x 1-1/4)	2
5	NS	Fuel Filter (Kohler)	1	43	NS	25-hp Engine	1
6	8026-12	HP Fuel Line (5/16 x 26) Filter to Engine	1	44	7306-12	Temperature Sender Adapter	1
7	7014-7	Fuel Line Guard	1	45	7306-15	Water Temperature Sender	1
8	8026-11	HP Fuel Line (5/16 x 16) Pump To Regulator	1	Fasteners			
9	8026-8	Vent Tube, Regulator	1	F002		10-24 Keps Nut	9
10	NS	Fuel Regulator (Kohler)	1	F004		1/4-20 Keps Nut	6
11	5879-3	Hose Clamp (1/2)	2	F009		5/16-18 Whiz Locknut	6
12	7014-2	Regulator/Filter Mount	1	F012		3/8-16 Keps Nut	5
13	7833	Cable Clamp (7/8 x 1/4)	1	F025		10-24 x 3/8 PPHMS	3
14	NS	Fuel Pump (Kohler)	1	F026		10-24 x 1/2 PPHMS	7
15	NS	Clamp (Kohler)	2	F029		1/4-20 x 1/2 Hex Bolt	4
16	5832	Cable Clamp (1/2)	1	F031		1/4-20 x 5/8 Hex Bolt	3
17	7014-5	Fuel Pump Mount	1	F032		1/4-20 x 3/4 Hex Bolt	1
18	7014-6	Fuel Pump Cover	1	F034		5/16-18 x 3/4 Hex Bolt	2
19	8026-9	Hose (5/16 x 8) Tank to Pump	1	F038		3/8-16 x 1 Hex Bolt	1
20	5083-2	Tank Tube Elbow	1	F041		3/8-16 x 1-3/4 Hex Bolt	4
21	5083-4	Plug Bushing (Viton)	1	F050		1/4 SAE Washer	2
22	5086-7	Fuel Line (3/8 x 6)	1	F051		3/8 SAE Washer	4
23	5020-2	Fuel Filter, In Tank	1	F061		1/4 Internal Star Lock Washer	2
24	8046-4	Fuel Tank, 5.0 Gallon, Gas, MTLEFI (Includes Items # 25, 26 & 27)	1	F063		3/8 Internal Star Lock Washer	3
25	5082-2	Fuel Cap Seal	1	F091		5/16-18 x 5/8 Hex Bolt	2
26	5082	Fuel Tank Cap (Includes Item # 25)	1	F151		3/8-16 x 7/8 Hex Bolt	2
27	5083-1	Bushing, Rubber	1	F187		1/4-20 x 1-1/2 Hex Bolt	2
28	7046-1	Fuel Return Tube	1	F188		1/4-20 Self-Locking Nut	2
				F255		5/16-18 x 1-1/2 Hex Bolt	2
Exhaust Assembly				NOTE: Refer to Kohler Engine Decal (NS) for Engine Identification Numbers.			
29	5665	Compression Spring (1/2 x 1)	2				
30	8530-15	Muffler End Shield	1				
31	8530-17	Upper Grass Shield	1				
32	8013-34	Muffler Mount Tab	1				
33	8013-31	Muffler	1				
34	8013-16	Mounting Spring, Muffler	2				
35	8013-33	Exhaust Pipe	1				
36	NS	Nut (Kohler)	4				
37	NS	Gasket (Kohler)	2				
38	NS	Oxygen Sensor (Kohler)	1				

Use only genuine Walker® replacement parts.

Effective Date 04-01-07

ENGINE GROUP (MTLEFI)

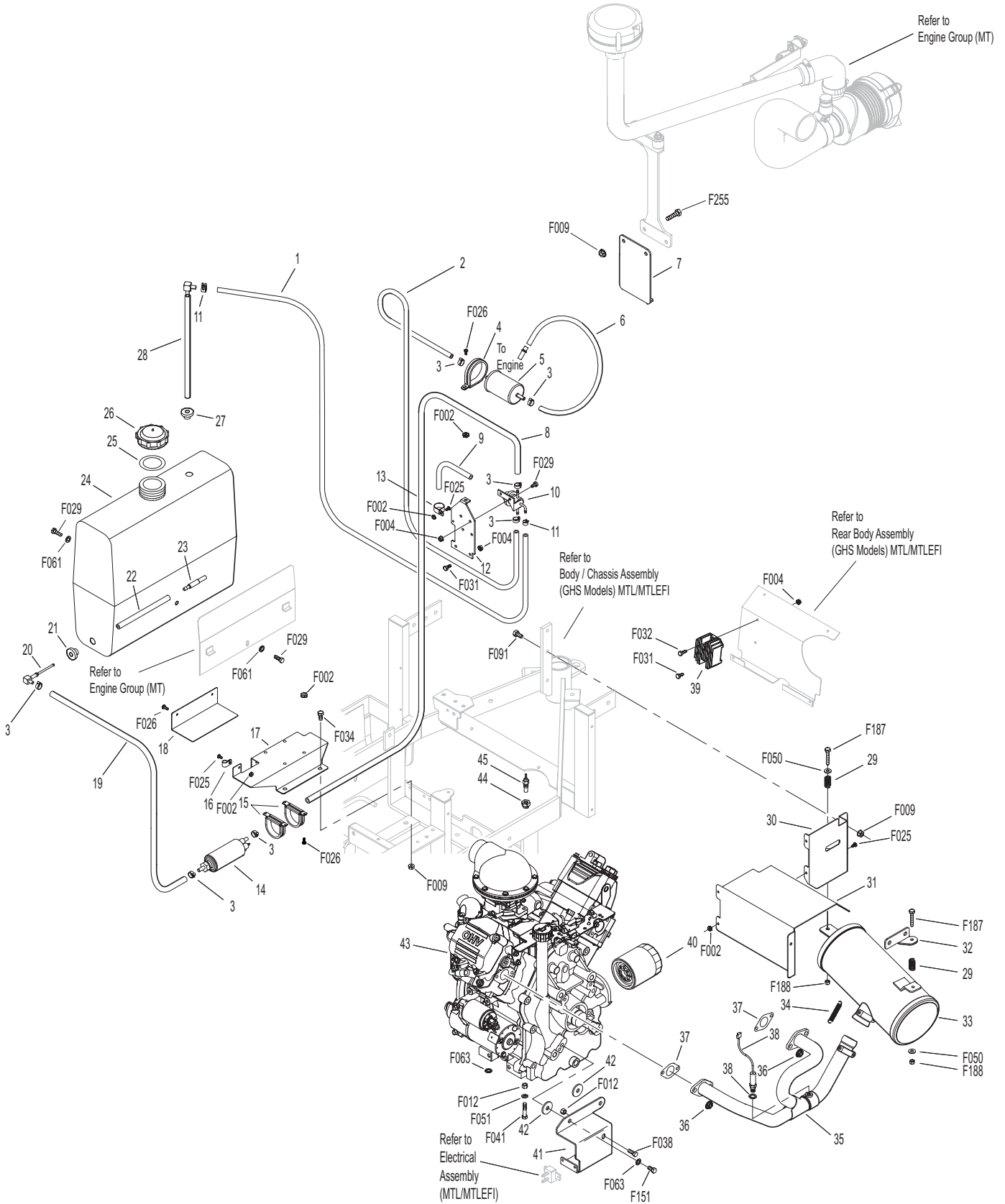

RADIATOR GROUP (MTL/MTLEFI)

ITEM NO.	PART NO.	DESCRIPTION	NO. REQ'D	ITEM NO.	PART NO.	DESCRIPTION	NO. REQ'D
Radiator Assembly				Fasteners			
1	7833-2	Cable Clamp (1 x 1/4)	2	F002		10-24 Keps Nut	4
2	7840-3	Hose Clamp (1/2 to 1-1/4)	2	F004		1/4-20 Keps Nut	4
3	7429-16	Exhaust Heat Shield	1	F014		3/8-16 ESNA Nut	2
4	8530-7	Exhaust Shield Mount, MTL	1	F025		10-24 x 3/8 PPHMS	3
5	7432	Shock Mount (1.00 OD x .75) Radiator	1	F026		10-24 x 1/2 PPHMS	1
6	7426-3	Rubber Isolator Mount	1	F029		1/4-20 x 1/2 Hex Bolt	4
7	7426-5	Screen Channel	2	F031		1/4-20 x 5/8 Hex Bolt	12
8	7426-7	Radiator Brace	1	F032		1/4-20 x 3/4 Hex Bolt	6
9	7425	Radiator Screen	1	F053		7/16 Int. Star Lock Washer	2
10	7426-8	Screen Stop	2	F061		1/4 Internal Star Lock Washer	14
11	7431-2	Radiator Channel Seal	2	F073		1/4 x 1.5 Fender Washer	2
12	7427-9	Radiator Cap	*	F129		10-24 x 1/2 PTHMS	7
13	7427-13	Radiator, MTL	1	F132		1/4-20 x 2-3/4 Hex Bolt	2
14	7426-6	Radiator Fan Shroud, MTL	1	F140		7/16-14 x 1 Hex Bolt	2
15	7427-22	Fan Mount Tab, RH	2	F360		1/4-20 x 3/8 Hex Bolt	1
16	7429-6	Radiator Cooling Fan	*				
17	7429-7	Fan Blade Replacement	*				
18	7427-21	Fan Mount Tab, LH	2				
19	7430-5	Radiator Guard	1				
20	7426-4	Radiator Mount	1				
21	7434	Rubber Washer (3/8 x 1-1/4 x 1/4)	4				
22	5841	Retainer Washer (3/8 x 1-1/4)	2				
23	7427-3	Coolant Recovery Tank	1				
24	7427-10	Recovery Tank Mount	1				
25	7427-11	Recovery Tank Keeper	1				
26	7015-13	Recovery Tank Hose	1				
27	5975-3	Cable Tie (50# x 7")	3				
28	7017-6	Lower Radiator Hose	1				
29	7840-4	Hose Clamp (3/4 to 1-1/2)	2				
30	7017-8	Upper Radiator Hose	1				
31	7017-7	Radiator Hose Bracket	1				

* Service Part Only

NOTE: Decals for this assembly are not shown here. Refer to **TRACTOR DECALS**, Page 2 for Decal listing and placement information.

RADIATOR GROUP (MTL/MTLEFI)

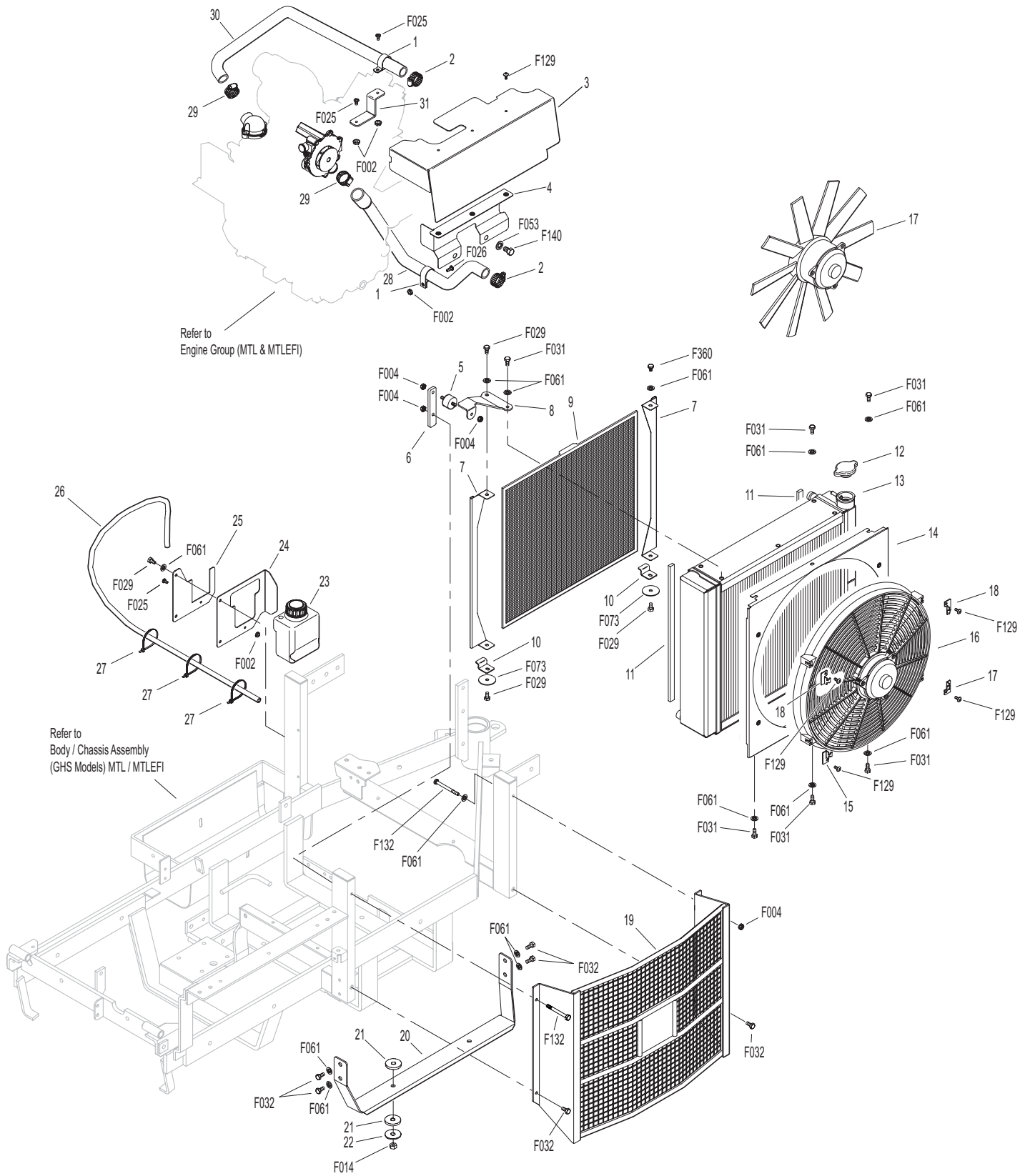

HYDROSTATIC GROUND DRIVE ASSEMBLIES

ITEM NO.	PART NO.	DESCRIPTION	NO. REQ'D	ITEM NO.	PART NO.	DESCRIPTION	NO. REQ'D
Transmission Lockout Assembly				Transmission Repair Parts			
1	5028-3	Transmission Lockout Assembly (Includes Items # 2-5, F023, F027 & F081)	*	26	5025-5	Input Shaft	*
2	5847	Plastic Tip	2	27	5025-8	Bearing, Input Shaft	*
3	5057	Lockout Cam (Includes Item # F081)	2	28	5025-7	Snap Ring	*
4	5028-5	Lockout Lever	2	29	5025-2	Seal, Input Shaft	*
5	5027-5	Lockout Mount	1**	30	5022	Reservoir to Casting Gasket	*
Ground Drive Assemblies				31	5024	Reservoir Cap and Gasket	*
6	6209-1	Bridge Assembly	1	32	5023	Transmission Reservoir Kit	*
7	6243-2	Hydro Fan, CCW	1	33	5023-1	Rubber Bladder	*
8	5026	Hydrostatic Drive, CW (700-041)	1	34	5025-6	O-Ring & Plug Assembly	*
9	6206-1	Air Vent Valve	*	35	5025-3	Seal, Control Shaft	*
10	6200-9	Gear Axle Drive Assembly (Includes Items # 9 & 11)	2	Fasteners			
11	6207-12	Pipe Plug (1/4 NPTF)	4	F012	3/8-16 Keps Nut		2
12	5126	Cable Retainer (Uses existing bolt on Gear Axle Drive Assembly)	1	F023	10-24 ESNA Nut		2
13	6233-1	Pinion Gear	2	F027	10-24 x 5/8 PPHMS		2
14	6234	Spacer, Pinion Gear	2	F036	1/4-20 x 1/2 SBH Screw		2
15	6201	O-Ring Seal	2	F038	3/8-16 x 1 Hex Bolt		4
16	7244	Hydro Pulley (3-7/8) (Includes Items # F064 & F359)	2	F040	3/8-16 x 1-1/2 Hex Bolt		4
17	6243-1	Hydro Fan, CW	1	F043	3/8-16 x 3 Hex Bolt		6
18	5025	Hydrostatic Drive, CCW (700-042)	1	F051	3/8 SAE Washer		2
Deck Support Arm Assemblies				F053	7/16 Internal Star Lock Washer		4
19	6430-10	Outboard Mount, LH	1	F063	3/8 Internal Star Lock Washer		14
20	6430-2	Deck Support Arm, LH (Includes Item # 24)	1	F064	1/8 x 1/2 Woodruff Key (#3)		4
21	5775-2	Hitch Pin (# 6)	2	F081	A/A45D Aluminum Pop Rivet		2
22	6430-1	Deck Support Arm, RH (Includes Item # 24)	1	F160	External Snap Ring (.669 Shaft)		2
23	6430-9	Outboard Mount, RH	1	F178	1/4 x 1 Fender Washer		2
24	5830	Grease Fitting	2	F194	7/16 x 1-1/4 x 1/8 Washer		2
25	6840-1	Support Arm Bushing (2-1/16)	2	F200	7/16-20 x 3 Grade 8 Bolt		2
				F244	7/16-20 x 3/4 Hex Bolt		2
				F262	3/8-16 x 4 Hex Bolt All Thread		1
				F359	5/16-18 x 5/16 Set Screw (Unbrako Knurl Point)		4
				F416	3/8-16 x 4 Soc Hd Cap Screw		1
				* Service Part Only			
				** Part not used on Jackshaft side of tractor.			

STEERING CONTROL ASSEMBLIES

ITEM NO.	PART NO.	DESCRIPTION	NO. REQ'D	ITEM NO.	PART NO.	DESCRIPTION	NO. REQ'D
Transmission Spring Assemblies				35	5450-3	Steering Lever Assembly, RH / Adjustable (Includes Items # 16, 21, 36, F188, F198 & F345)	1
1	6199	Transmission Spring Assembly (RH) (Includes Items # 2-8, F003, F287, F320 & F352)	*		5450-5	Steering Lever Arm, RH / Adjustable	*
2	5552	Ball Joint (1/4-28)	2		5450-6	Steering Lever Assy RH / Adjustable / MTL	*
3	5192-1	Spring Plunger (Male)	2	36	5453-10	Steering Lever Handle, Adjustable (Includes Items # 21 & F345)	2
4	5194	Plunger Sleeve	2				
5	5193	Washer (3/4 x 1 x .085)	2	37	5862	FSC Knob	1
6	6191	Spring Slide (4-3/4)	1	38	7170	FSC Lever Assembly (Includes Item # 16)	1
7	5195-1	Compression Spring (1 x 6-1/4)	2				
8	6196	Spring Slide Cap	1	39	5975-3	Cable Tie (50# x 7")	1
9	5197	J-Bolt	1	40	5213-1	Control Rod, RH (15")	1
10	5191	Spring Slide (3-5/8)	1	41	6201-2	Shock Mount Gear Drive/RH	1**
11	5199	Transmission Spring Assembly (LH) (Includes Items # 2-5, 7, 9, 10, F003, F146, F287 & F352)	*	42	5146	10mm Ball Stud	4**
Steering Lever & FSC Assemblies				43	4215-2	Steering Lever Dampener	2**
12	5214-2	Ball Joint (5/16-24) Nylon Lined	2	44	5450-4	Steering Lever Arm RH / Adjustable / MTL	1**
13	5173	FSC Actuator Rod	1	45	5451-4	Steering Lever Arm LH / Adjustable / MTL	1**
14	5172	Bearing, Nylon (.255 ID x .379 OD x .250)	1	46	6201-1	Shock Mount Gear Drive/LH	1**
15	5142-2	FSC Actuator Cam	1	Fasteners			
16	5830	Grease Fitting	6	F003	1/4-28 Hex Nut		3
17	6212	Transmission Control Arm, RH	1	F004	1/4-20 Keps Nut		8
18	5141	FSC Friction Washer (1-1/2 x 3/8 x 1/16)	2	F007	5/16-18 Jam Nut		1
19	5140-15	FSC Friction Body (Includes Item # 16)	1	F008	5/16-24 Keps Nut		2
20	5142-7	FSC Key W/Stop	1	F009	5/16-18 Whiz Locknut		5
	5140-13	FSC Control Assembly (Includes Items # 16, 18-20, F192 & F193)	*	F010	5/16-24 ESNA Nut		2
21	5850-2	Handle Grip, Foam (5-1/2)	2	F012	3/8-16 Keps Nut		2
22	5212-2	Transmission Control Arm, LH	1	F024	5/16-24 Jam Nut		2
23	5213-2	Control Rod, LH (6")	1	F029	1/4-20 x 1/2 Hex Bolt		2
24	5223	Extension Spring (1/4 x 5-1/2)	2	F032	1/4-20 x 3/4 Hex Bolt		4
25	5450	D-Clip	2	F034	5/16-18 x 3/4 Hex Bolt		1
26	5463	Steering Lever Actuator	2	F050	1/4 SAE Washer		3
27	5214-1	Bearing (.320 x .438 x .250)	2	F051	3/8 SAE Washer		2
28	5391-3	Steering Lever Support	1	F064	1/8 x 1/2 Woodruff Key (#3)		2
29	5217	Pivot Pin, Steering Lever	1	F068	1/8 x 1 Cotter Pin		1
30	5451-3	Steering Lever Assembly, LH / Adjustable (Includes Items # 16, 21, 36, F188, F198 & F345)	1	F069	3/32 x 1/2 Cotter Pin		1
	5451-5	Steering Lever Arm, LH / Adjustable	*	F093	5/16-18 x 1 Hex Bolt		1
	5451-6	Steering Lever Assy, LH / Adjustable / MTL	*	F146	1/4-20 Jam Nut		1
31	5219	Extension Spring (3/4 x 6-3/4)	1	F182	1/4 x 5/8 x 1/8 Washer		2
32	5280-1	Turnbuckle Clevis (1/4")	1	F183	.312 x .700 x .074 Washer		2
33	5281-5	Clevis Pin (1/4 x 0.80)	1	F186	5/64 x 1/2 Cotter Pin		1
34	5470-1	Speed Control Stop	1	F188	1/4-20 Self-Locking Nut		4
				F192	3/8-24 Self-Locking Nut		1
				F193	3/8 Belleville Spring Washer		3
				F198	.250 x .625 x .040 Washer, SS		2
				F287	1/4-28 Keps Nut		2
				F320	1/8 x 3/4 Split Spring Pin		1
				F345	1/4-20 x .770 Knurled Bolt		4
				F352	5/32 x 1 Heavy Duty Roll Pin		2
				F401	.504 x .751 x .030 Washer		1

* Service Part Only

** All parts for Steering Dampener MTL & MTLEFI only.

STEERING CONTROL ASSEMBLIES

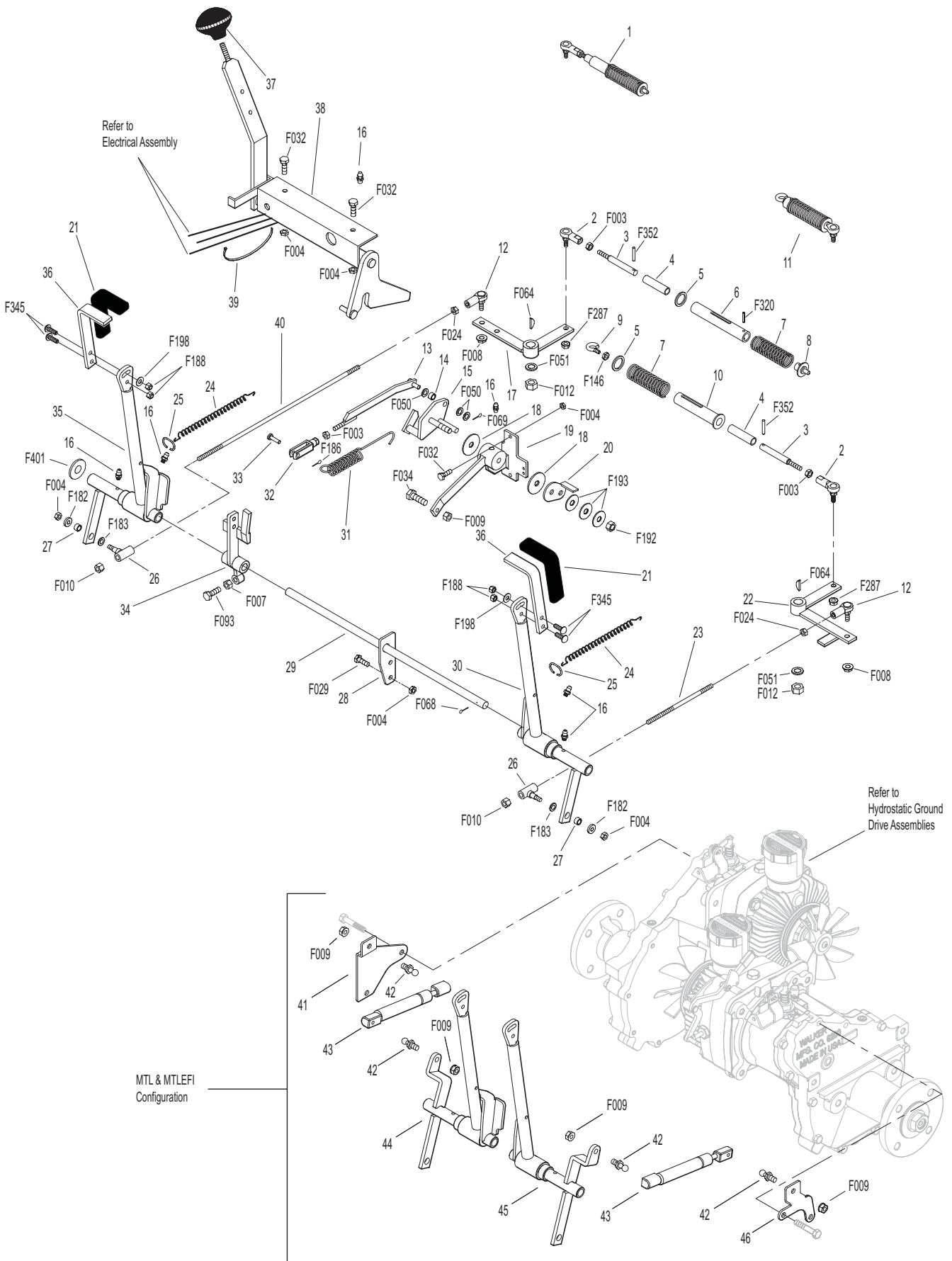

Effective Date 04-01-07

Use only genuine Walker® replacement parts.

THROTTLE & CHOKE CONTROL ASSEMBLY

ITEM NO.	PART NO.	DESCRIPTION	NO. REQ'D	ITEM NO.	PART NO.	DESCRIPTION	NO. REQ'D
Throttle & Choke Control Assemblies				Fasteners			
1	8121-1	Throttle Cable	1		F004	1/4-20 Keps Nut	4
2	8122-1	Choke Cable	1		F005	1/4-20 ESNA Nut	2
3	5172	Bearing, Nylon (.255 x .379 x .250)	2		F029	1/4-20 x 1/2 Hex Bolt	4
4	5108-7	Control Lock Tab	2		F050	1/4 SAE Washer	1
5	5108-10	Friction Washer (.125)	2		F164	10-24 x 1/4 x 3/8 SHL Bolt	1
6	5108-1	Control Lever, Throttle & Choke	2		F201	1/4 Belleville Spring Washer	4
7	5108-5	Throttle Control Knob, Red	1				
8	5108-11	Friction Washer (.062)	2	*	Service Part Only		
9	5108-8	Control Bracket	2				
10	7108	Control Assembly (Includes Items # 4-6, 8, 9 & F201)	2	Δ	Model MTEFI and MTLEFI do not use choke.		
	8121	Throttle Control and Cable Assembly (Includes Item # 7)	*				
	8122	Choke Control and Cable Assembly (Includes Item # 11)	*Δ				
11	5108-6	Choke Control Knob, Black	1				
12	8123	Insulation Sleeve (3/8 x 6)	1				
13	5975-1	Cable Tie (18# x 3-3/4")	1				

THROTTLE & CHOKE CONTROL ASSEMBLY

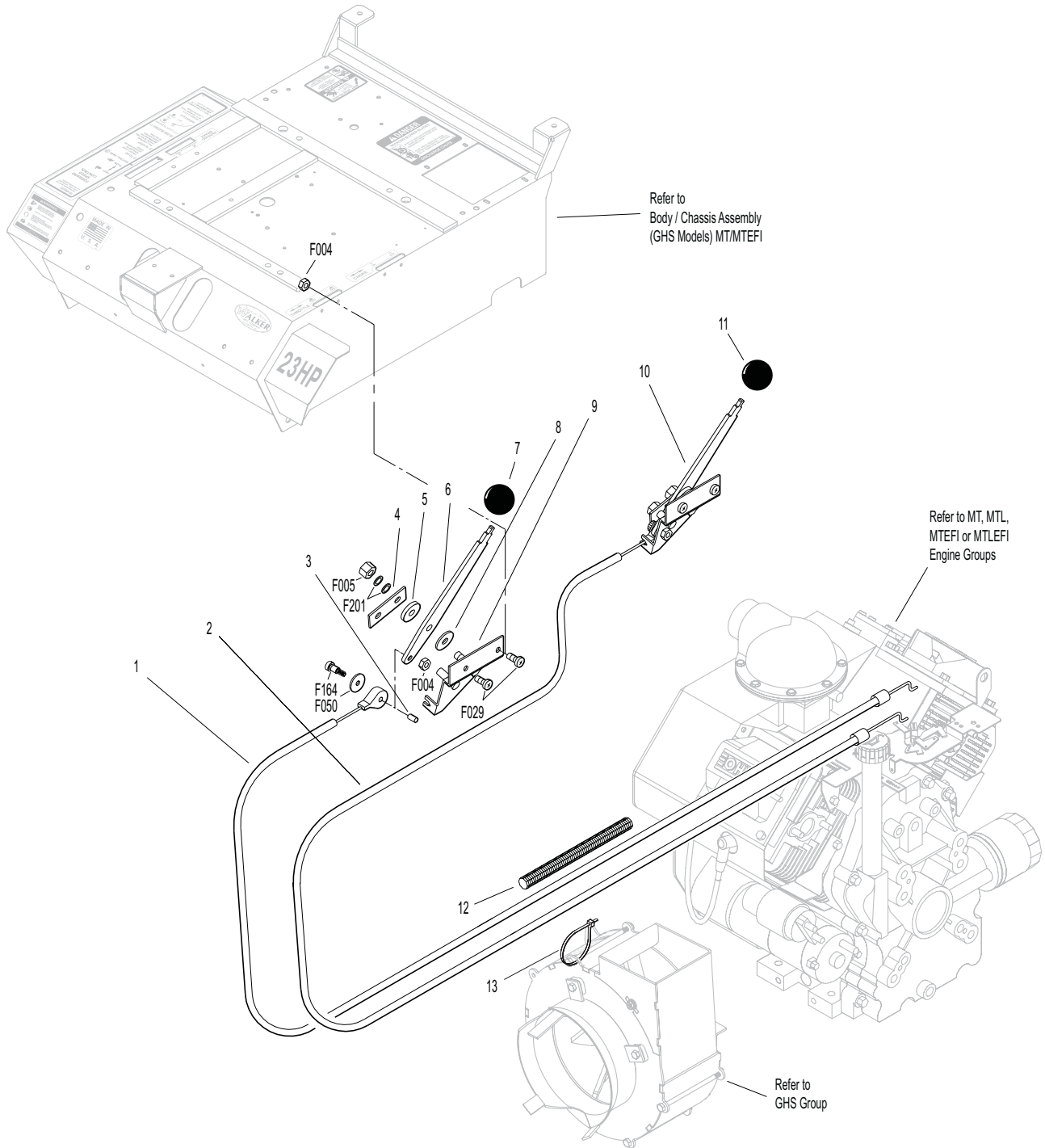

PARKING BRAKE ASSEMBLY

ITEM NO.	PART NO.	DESCRIPTION	NO. REQ'D	ITEM NO.	PART NO.	DESCRIPTION	NO. REQ'D
Parking Brake Assembly				Fasteners			
1	7406-1	Handle Grip, Red	1	F002		10-24 Keps Nut	2
2	7406-8	Parking Brake Lever (4-1/4)	1	F003		1/4-28 Hex Nut	1
3	7406-2	Lever Mount	1	F004		1/4-20 Keps Nut	4
4	5830	Grease Fitting	1	F025		10-24 x 3/8 PPHMS	2
5	7407	Clevis Pin (3/16 x 1/2)	2	F029		1/4-20 x 1/2 Hex Bolt	3
6	7404	Brake Actuator Arm	2	F032		1/4-20 x 3/4 Hex Bolt	1
7	7405	Pin, Transmission Lock	2	F054		AN960616 Washer	2
8	7402	Clevis	2	F072		1/4 "E" Retainer Ring	2
9	7408	Compression Spring (1/2 x 3/4)	2	F086		#10 SAE Washer	4
10	7415	Rubber Dust Shield (5/8 x 3/8 x 1/32)	2	F109		1/8 x 5/8 Roll Pin	2
11	5567-3	O-Ring Seal (1/4 x 3/8)	4	F111		1/8 x 3/4 Cotter Pin	1
12	7403	Plunger Bushing, Gear Axle	2	F112		5/8 x 1-1/4 x .03 Washer	2
13	7404-1	Brake Actuator Mount	2	F127		1/16 x 1/2 Cotter Pin	4
14	7412	Clevis Pin (3/16 x 5/8)	2	F261		AN960616L Washer	5
15	5833	Cable Clamp (1/4)	2	F287		1/4-28 Keps Nut	1
16	7410	Brake Control Cable, LH (25.5")	1				
17	7409	Brake Control Cable, RH (20.5")	1				
18	7401-3	Cable Mount Bracket	1				
19	7401-1	Cable Pull Rod	1				
20	5552	Ball Joint (1/4-28)	1				

PARKING BRAKE ASSEMBLY

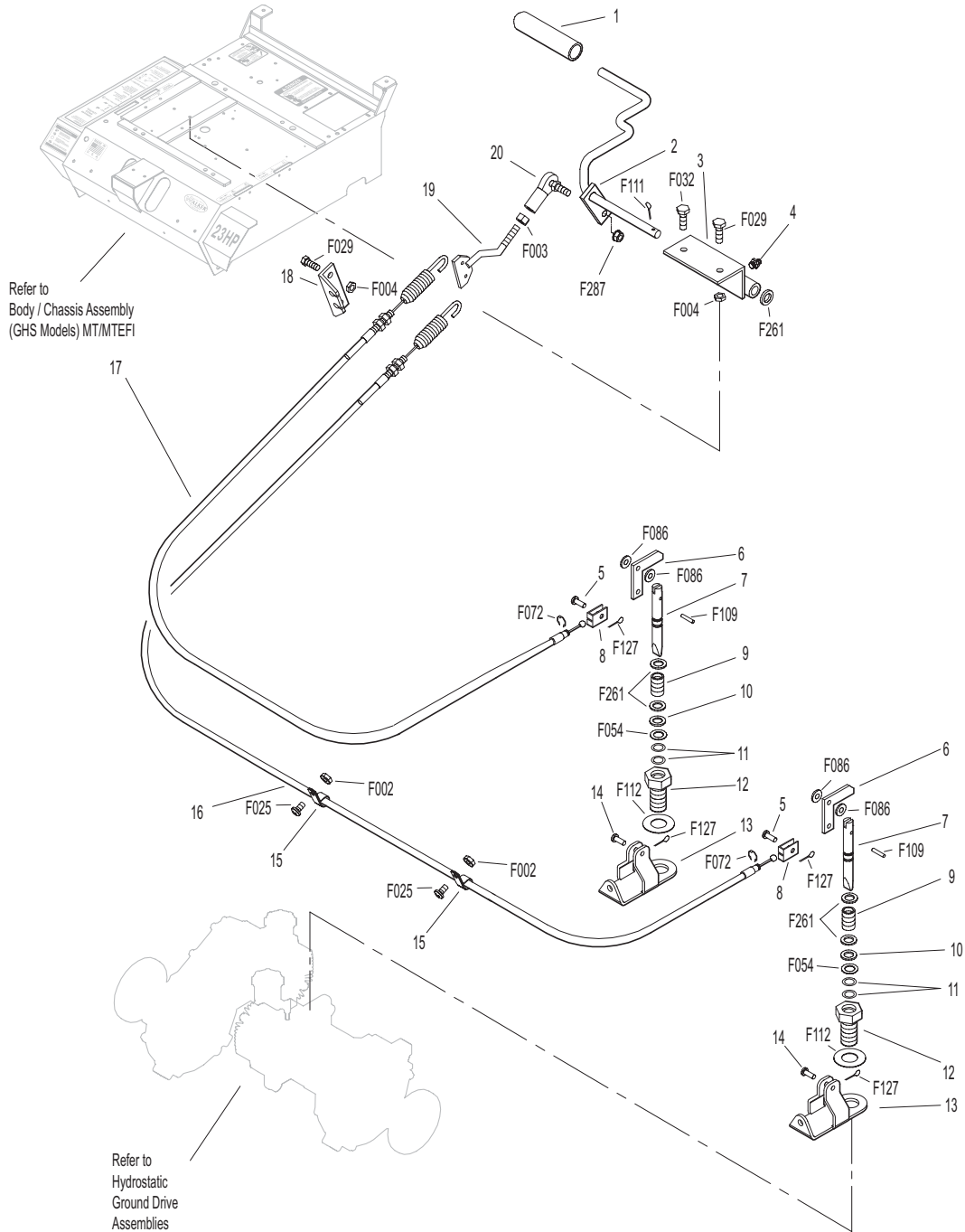

GHS GROUP

ITEM NO.	PART NO.	DESCRIPTION	NO. REQ'D
----------	----------	-------------	-----------

Delivery Chute Assembly

When Optional 7.0 Bushel Catcher Assembly is purchased, Item # 6 is replaced by P/N 7511-1 (Delivery Chute Assembly, 7.0).

1	5515-2	Elbow Delivery Spout	1
2	5592-13	Backing Plate, Grass-Pak [®] Switch	1
3	5592-12	Mount Plate, Grass-Pak [®] Switch	1
4	5578	Rear Clip, Chute Mount	1
5	5577	Side Clip, Chute Mount	2
6	8511-1	Delivery Chute W/Clips / 9.5 (Includes Items # 4, 5, 7, F362 & F411)	1
	7511-1	Delivery Chute W/Clips / 7.0 (Includes Items # 4, 5, 7, F362 & F411)	*
7	5578-10	Front Clip, Chute Mount	1
8	7530-4	Body Chute (10.5 Blower)	1

Blower Belt Tightener Assembly

9	7238-6	Blower Drive Pulley (Includes Items # F075, F114 & F231)	1
10	7234-2	Blower Belt (Micro-V)	1
11	7239-1	Blower Pulley (Mirco-V) (Includes Items # F067, F075 & F114)	1
12	7364-2	Torsion Spring	1
13	7201-3	DU Bearing	2
14	5830-3	Grease Fitting (45 Deg.)	1
15	7364-1	Blower Belt Tightener Arm	1
16	7201-4	Inner Race (1-1/2)	1
17	5841	Retainer Washer (3/8 x 1-1/4)	1
18	5245	Idler Pulley (3")	1

Blower Assembly

19	7542	Blower Assembly (10.5") (Includes Items # 20-27, F004, F029, F050, F061, F131, F132, F168, F246 & F414)	1
20	5268	Bearing W/Collar (3/4)	2
21	7542-2	Blower Back Plate (10.5)	1
22	7545-2	Blower Output Shaft (10.5)	1
23	7545	Blower Wheel (10.5")	1
24	7542-4	Blower Scroll (10.5)	1
25	7542-5	Blower Coupler Nut	1
26	7542-3	Blower Faceplate (10.5)	1
27	7526	Intake Tube (10.5 Blower)	1
28	5595-2	Intake Cover/GHS	**
29	7528-2	Skid Bar (10.5" Blower)	1

ITEM NO.	PART NO.	DESCRIPTION	NO. REQ'D
----------	----------	-------------	-----------

Fasteners

F002	10-24 Keps Nut	8
F004	1/4-20 Keps Nut	8
F009	5/16-18 Whiz Locknut	1
F012	3/8-16 Keps Nut	3
F025	10-24 x 3/8 PPHMS	2
F026	10-24 x 1/2 PPHMS	2
F029	1/4-20 x 1/2 Hex Bolt	3
F034	5/16-18 x 3/4 Hex Bolt	1
F039	3/8-16 x 1-1/4 Hex Bolt	1
F040	3/8-16 x 1-1/2 Hex Bolt	1
F042	3/8-16 x 2-1/4 Hex Bolt	1
F050	1/4 SAE Washer	1
F054	AN960616 Washer	1
F061	1/4 Star Lock Washer	2
F067	3/16 x 3/16 x 1 Key	1
F075	5/16-18 x 1/2 SQH Set Screw	2
F079	A/A66D Aluminum Pop Rivet	6
F090	1/4-20 x 2-1/2 Hex Bolt	3
F102	10-24 x 1-1/2 PTHMS	2
F114	5/16-18 x 5/8 SQH Set Screw	2
F128	10-24 x 3/8 PTHMS	4
F131	5/16-18 x 1/2 Hex Bolt	3
F132	1/4-20 x 2-3/4 Hex Bolt	1
F168	5/16 Split Lock Washer	3
F217	7/16-14 Hex Nut	1
F218	7/16 Split Lock Washer	1
F231	1/4 x 3/4 Woodruff Key (# 806)	1
F246	1/4-20 x 1/2 PTHMS	1
F281	7/16-14 x 1-3/4 Hex Bolt	1
F362	A/A62D Alum. Pop Rivet (3/16D x 13/32L)	2
F411	3/16 Bulbex Rivet	6
F414	1/4-20 x 5-1/8 Gd 5 Hex Bolt	5

* Service Part Only

** Plugs Blower when GHS is not in use. Furnished only with Mulching Decks, SD Decks used on a GHS Tractor, Rotary Broom Attachment and Snowblower Attachment. Use of this part may be replaced by installing Blower Lockout Kit (P/N 7541). See Page 84.

GHS GROUP

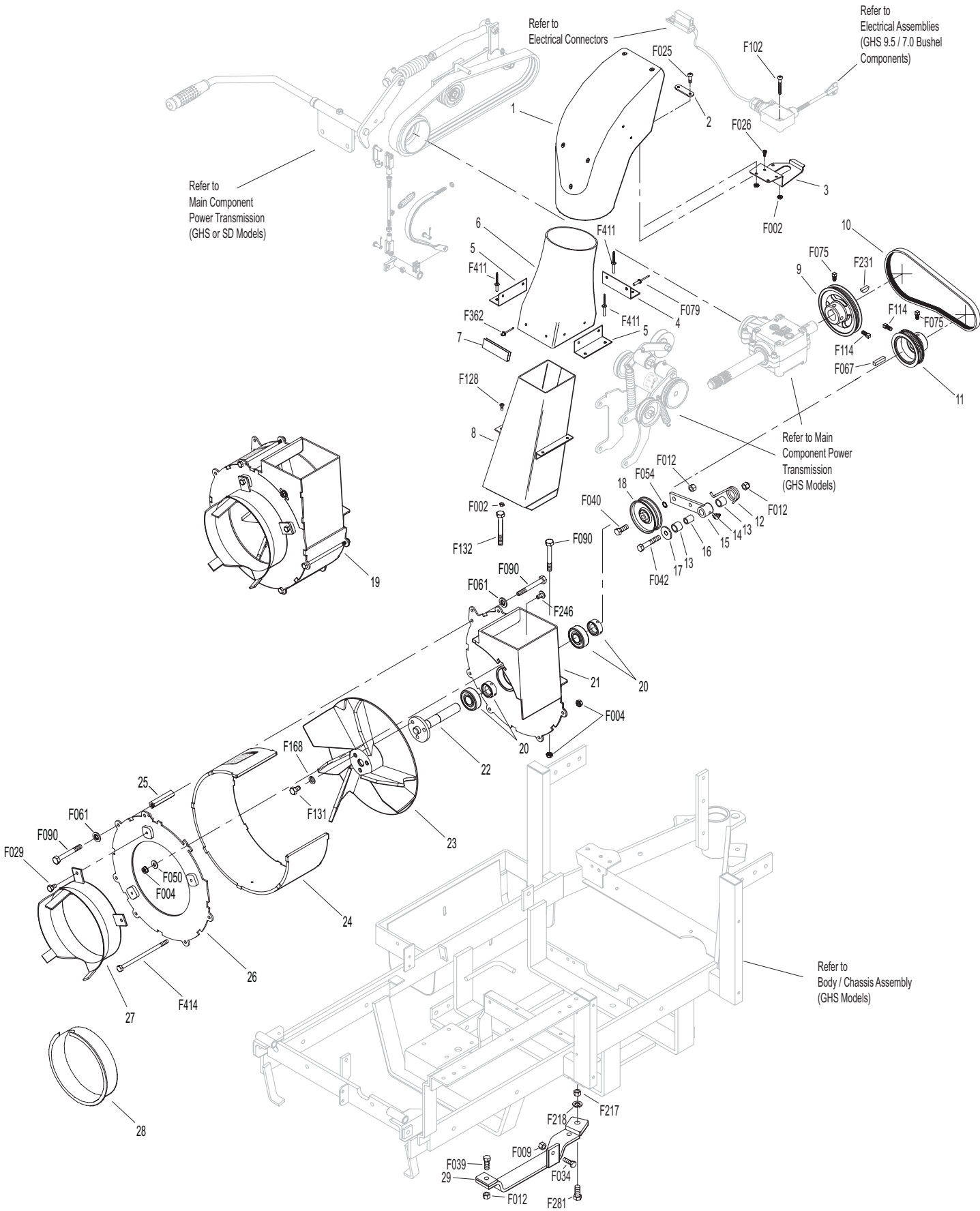

Effective Date 04-01-07

Use only genuine Walker® replacement parts.

GHS POWERFIL® ASSEMBLY

ITEM NO.	PART NO.	DESCRIPTION	NO. REQ'D	ITEM NO.	PART NO.	DESCRIPTION	NO. REQ'D
GHS Powerfil® Assembly				Fasteners			
1	5557	Motor Mount, Powerfil®	1	F002		10-24 Keps Nut	10
2	5551-3	Bearing Cap, Powerfil®	1	F003		1/4-28 Hex Nut	3
3	5551-1	Pivot Bearing (#S3PP)	2	F025		10-24 x 3/8 PPHMS	1
4	5552	Ball Joint (1/4-28)	2	F037		10-24 x 5/8 PTH Screw	1
5	5518-2	Pivot, Delivery Spout	1	F054		AN960616 Washer	1
6	5517-2	Pivot Mount	1	F085		3/16 Rivet Backup Washer	1
7	5558-1	Powerfil® Push Rod	1	F101		10-24 x 1-1/4 SHC Screw	1
8	5553-3	Bushing, Powerfil® Actuator	4	F109		1/8 x 5/8 Roll Pin	1
9	5558-2	Powerfil® Actuator Rod	1	F129		10-24 x 1/2 PTHMS	3
	5549	Actuator Rod Assembly (Includes Items # 4, 7-10 & F003)	*	F261		AN960616L Washer	1
10	5553-1	Compression Spring (1/2 x 2)	2	F287		1/4-28 Keps Nut	1
11	5554	Actuator Arm	1	* Service Part Only			
12	5519-3	Motor Mount Nut (5/8-24)	*				
13	5519-2	Motor Mount Washer	*				
14	5519	Actuator Motor (12/24V) (Includes Items # 12 & 13)	1				
15	5977	Grommet (1/2 x 7/8 x 1/16)	1				

GHS POWERFIL® ASSEMBLY

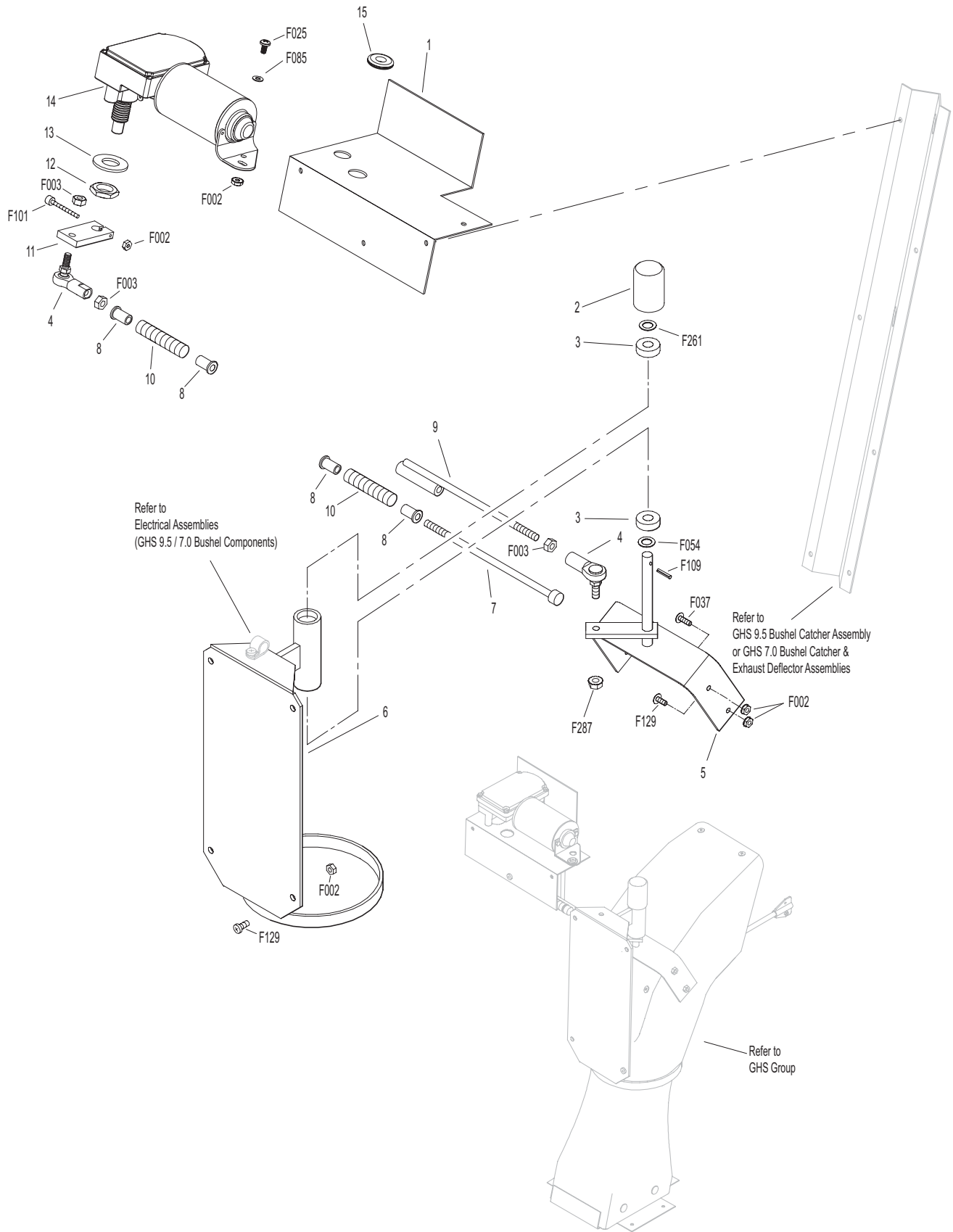

GHS 9.5 BUSHEL CATCHER ASSEMBLY

ITEM NO.	PART NO.	DESCRIPTION	NO. REQ'D	ITEM NO.	PART NO.	DESCRIPTION	NO. REQ'D
Upper Baffle Screen Assembly (Removable)				32	5155-13	3/4 Ball Stud	2
1	7509-3	Channel Bottom	2	33	5523-6	Gas Spring Plate	2
2	7505	Mustache Spring	2	34	7533	Backing Plate, Handle	2
3	7507	Screen Seal (27-1/2)	1	35	7532	Handle, Catcher Lift	2
4	7856-1	Edge Molding (26")	1	36	5155-15	Box Support, Gas Spring	2
5	7509-2	Channel Top	2	37	8117	9.5 Wire Harness Channel	1
6	7512-2	Removable Screen (3/16 Holes) (Includes Items # 7, F025 & F190)	1**	38	5976	Grommet (3/8 x 11/16)	2
7	7506	Knob/Threaded Insert (10-24)	2	39	7508	Safety Latch Kit (7.0/9.5)	1
8	7509-4	C-Channel	1	40	5522-2	Hinge Backup Plate, RH	1
Exhaust Deflector Assembly				Fasteners			
9	7504-3	Hinge (27")	1	F002	10-24 Keps Nut		29
10	7504-1	Exhaust Deflector (Two Piece Set)	1	F004	1/4-20 Keps Nut		16
	7504	Exhaust Deflector Kit	*	F009	5/16-18 Whiz Locknut		2
11	7504-8	Deflector Mount Doubler	2	F020	5/16-18 ESNA Nut		2
GHS 9.5 Bushel Catcher Assembly				F025	10-24 x 3/8 PPHMS		4
12	8514-11	9.5 Door Frame	1	F026	10-24 x 1/2 PPHMS		4
13	8510-1	9.5 Bushel Catcher, Including Door	1	F027	10-24 x 5/8 PPHMS		4
	8502-1	9.5 Catcher Without Powerfil® (Includes Door & Deflector)	*	F035	5/16-18 x 1-1/4 Hex Bolt		1
	8502-2	9.5 Catcher With Powerfil® (Includes Door & Deflector)	*	F037	10-24 x 5/8 PTH Screw		6
14	5583	Handle	1	F049	5/16 SAE Washer		4
15	7514-1	Backup Plate	1	F069	3/32 x 1/2 Cotter Pin		2
16	5588	Rubber Bumper (.75 x .50)	2	F079	A/A66D Aluminum Pop Rivet		20
17	8516	Side Strap, Door / 9.5	2	F085	3/16 Rivet Backup Washer		15
18	8503	Mounting Frame (Includes Item # 26)	1	F129	10-24 x 1/2 PTHMS		8
19	7512-10	Deflector Seal	1	F172	1/4-20 x 3/4 Carriage Bolt		4
20	5281-5	Clevis Pin (1/4 x .080)	2	F188	1/4-20 Self-Locking Nut		16
21	8513-3	9.5 Mounting Frame Doubler	1	F190	#10 Internal Star Lock Washer		2
22	7610-1	Dump Plate Slide	2	F195	1/4-20 x 3/4 PPHMS, SS		7
23	7584	Reinforcing Strap	2	F196	1/4-20 x 1 PPHMS, SS		3
24	7610	Catcher Dump Plate	1	F198	.250 x .625 x .040 Washer, SS		5
25	5522-1	Hinge Backup Plate, LH	1	F228	#6 x 5/8 PPHSMS, SS		2
26	7503-9	Pivot Bushing (5/16 x 5/8)	2	F230	1/4-20 x 1-1/4 PPHMS, SS		1
27	5155-12	5/16 Ball Stud	2	F242	1/4-20 x 7/8 PPHMS, SS		23
28	5524-1	Flanged Hinge Bearing	2	F252	10-24 x 3/4 PPHMS		1
29	5147	Spring Clip	4	F255	5/16-18 x 1-1/2 Hex Bolt		1
30	5155	Gas Spring Assembly / Catcher Door (Includes Items # 27, 29, 32 & F049)	2	F329	.200 ID x 1.939 OD Washer		2
31	5155-2	Gas Spring Cover	2	F330	3/16 D x 21/32 L Rivet, SS		2
				F340	Rivet, Aluminum		4
				F351	Aluminum Pop Rivet		3
				* Service Part Only			
				** This screen can be replaced by P/N 7512-3 Removable Screen (3/4" hole) for improved air flow performance in wet conditions.			

NOTE: Refer to **ELECTRICAL CONNECTORS**, Page 64 for identification of all Electrical Wiring Service Parts.

Use only genuine Walker® replacement parts.

Effective Date 04-01-07

GHS 7.0 BUSHEL CATCHER & EXHAUST DEFLECTOR ASSEMBLIES

ITEM NO.	PART NO.	DESCRIPTION	NO. REQ'D
GHS 7.0 Bushel Catcher Assembly			
May be ordered as a factory-installed option. Contact your Walker dealer.			
1	7503	Mounting Frame (7.0) (Includes Item # 12)	1
2	7510-1	7.0 Bushel Catcher, Including Door	1
	7502-1	7.0 Catcher, Without Powerfil® (Includes Door & Deflector)	*
	7502-2	7.0 Catcher (With Powerfil®) (Includes Door & Deflector)	*
3	7514-1	Backup Plate	1
4	5583	Handle	1
5	5588	Rubber Bumper (.75 x .50)	2
6	7522	Side Strap, Door (7.0)	2
7	7513-2	7.0 Mounting Frame Doubler	1
8	7512-10	Deflector Seal	1
9	5281-5	Clevis Pin (1/4 x 0.80)	2
10	7584	Reinforcing Strap	2
11	5522-1	Hinge Backup Plate, LH	1
12	7503-9	Pivot Bushing (5/16 x 5/8)	2
13	7514-10	7.0 Door Frame, Catcher	1
14	5155-12	5/16 Ball Stud	2
15	5147	Spring Clip	4
16	5155-2	Gas Spring Cover	2
17	5155	Gas Spring Assembly / Catcher Door (Includes Items # 14, 15, 19 & F049)	2
18	5524-1	Flanged Hinge Bearing	2
19	5155-13	3/4 Ball Stud	2
20	5523-6	Gas Spring Plate	2
21	7532	Handle, Catcher Lift	2
	7534	Catcher Handle Kit (Includes Items # 21, 22, F004 & F172)	*
22	7533	Backing Plate, Handle	2
23	5155-15	Box Support, Gas Spring	2
24	7557-10	7.0 Wire Harness Channel	1
25	5976	Grommet (3/8 x 11/16)	1
26	5976-2	Grommet (3/16 x 3/4)	1
27	5522-2	Hinge Backup Plate, RH	1
28	7508	Safety Latch Kit (7.0/9.5)	1

ITEM NO.	PART NO.	DESCRIPTION	NO. REQ'D
5598 Optional Dump Bag (Not Shown)			
May be ordered as an option. Contact your Walker dealer. Not used with Power Dump Option.			
Fasteners			
	F002	10-24 Keps Nut	14
	F004	1/4-20 Keps Nut	13
	F009	5/16-18 Whiz Locknut	2
	F020	5/16-18 ESNA Nut	2
	F026	10-24 x 1/2 PPHMS	4
	F027	10-24 x 5/8 PPHMS	4
	F035	5/16-18 x 1-1/4 Hex Bolt	1
	F037	10-24 x 5/8 PTH Screw	2
	F049	5/16 SAE Washer	4
	F069	3/32 x 1/2 Cotter Pin	2
	F079	A/A66D Aluminum Pop Rivet	11
	F085	3/16 Rivet Backup Washer	9
	F129	10-24 x 1/2 PTHMS	4
	F172	1/4-20 x 3/4 Carriage Bolt	4
	F188	1/4-20 Self-Locking Nut	11
	F195	1/4-20 x 3/4 PPHMS, SS	14
	F196	1/4-20 x 1 PPHMS, SS	4
	F198	.250 x .625 x .040 Washer, SS	8
	F230	1/4-20 x 1-1/4 PPHMS, SS	1
	F242	1/4-20 x 7/8 PPHMS, SS	9
	F252	10-24 x 3/4 PPHMS	1
	F255	5/16-18 x 1-1/2 Hex Bolt	1
	F329	.200 ID x 1.939 OD Washer	2
	F330	3/16 D x 21/32 L Rivet, SS	2
	F351	Aluminum Pop Rivet	3

* Service Part Only

GHS 7.0 BUSHEL CATCHER & EXHAUST DEFLECTOR ASSEMBLIES

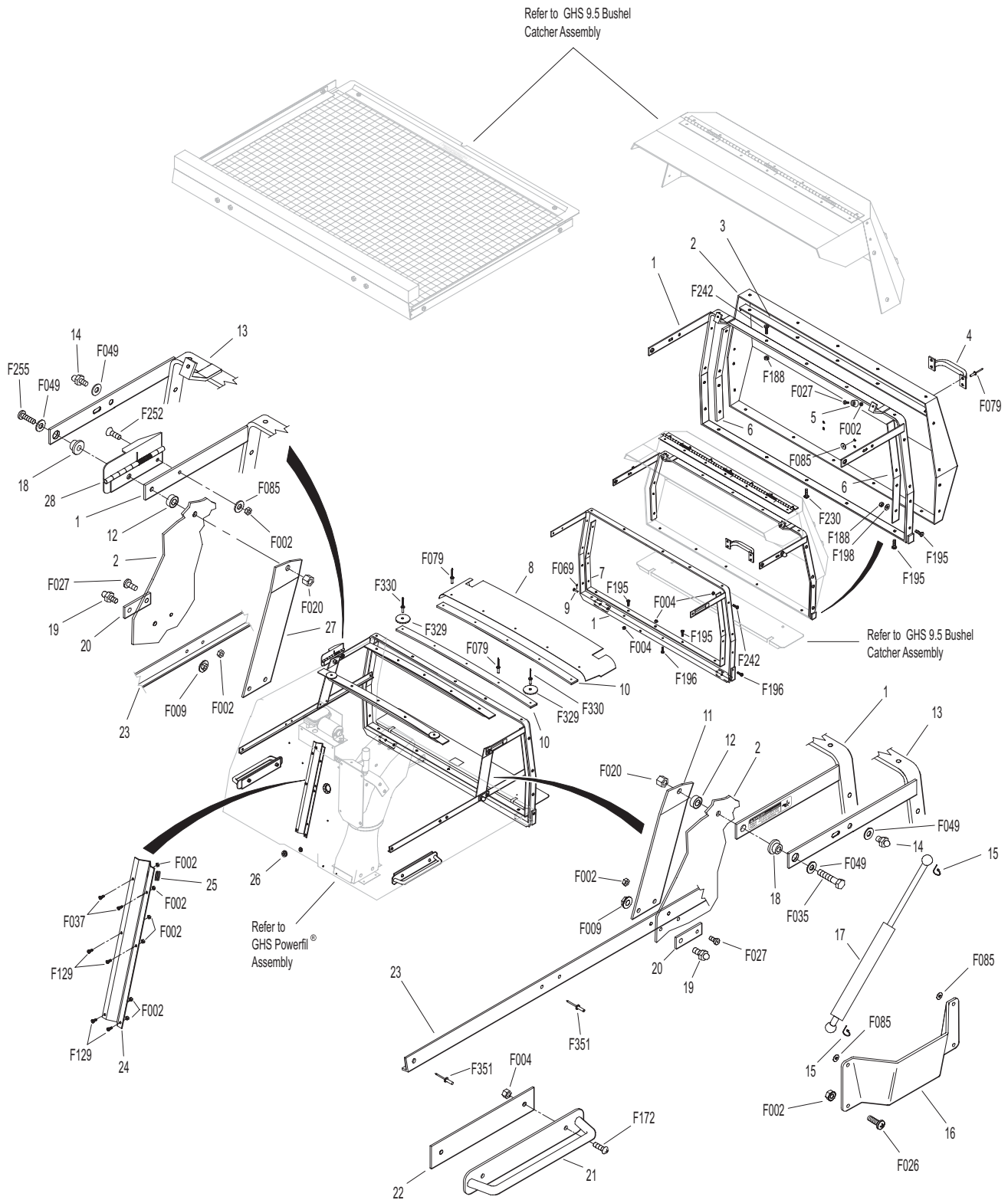

INSTRUMENT PANEL ASSEMBLY (MT)

ITEM NO.	PART NO.	DESCRIPTION	NO. REQ'D	ITEM NO.	PART NO.	DESCRIPTION	NO. REQ'D
Instrument Panel Assembly				20	8536	Warning Horn	1
1	7307-2	Instrument Panel Cover (Optional)	**	21	8960-15	Ignition Switch (with Keys) (Includes Items # 23, 24 & F349)	1
	8306-4	Instrument Panel Assembly (Includes Items # 2-12, 14, 21, 22, 24-26, F228, F250, F251 & F349)	1	22	8996-2	Red Indicator Light Assembly (Includes Items # 25 & 26)	2
2	7307	Panel Frame	1	23	7854	Plastic Tip, Red	1
3	8823-2	Decal, Instrument Panel	1	24	8960-3	Key Set W/Umbrella	*
4	8820-13	Panel Faceplate	1	25	8996-4	Red Indicator Lens	2
5	7386	Panel Gasket	1	26	8996-3	Indicator Bulb (Replacement for P/N 8996-2)	*
6	6941	Relay Switch (30/40 Amp)	2	Fasteners			
7	7941-3	Boot, Circuit Breaker	1		F004	1/4-20 Keps Nut	6
8	7941-5	Circuit Breaker (7 Amp)	1		F228	#6 x 5/8 PPHSMS, SS	8
9	5995-2	Switch Boot	1		F238	J Clip, Instrument Panel	8
10	5995	Toggle Switch (Off-On)	1		F250	6-32 x 1/2 PPHMS	2
11	8997	Voltmeter Gauge	1		F251	6-32 Keps Nut	2
12	8990-1	Hourmeter (SenDec)	1		F349	Washer .835 ID 1.122 OD, SS	1
13	5975-1	Cable Tie (18# x 3-3/4")	2	* Service Part Only			
14	8945-3	Wire Harness, Instrument Panel	1	** May be ordered as an option. Contact your Walker dealer.			
15	7307-16	Lining 1/8, Panel Box	1	NOTE: Refer to ELECTRICAL CONNECTORS , Page 64 for identification of all Electrical Wiring Service Parts.			
16	7391	Panel Box Mount Plate	2				
17	7977-1	Grommet (1/8 x 1-1/16)	1				
18	7307-1	Shock Mount (1.0 x .25)	3				
19	8385	Panel Box W/Graphic	1				

INSTRUMENT PANEL ASSEMBLY (MT)

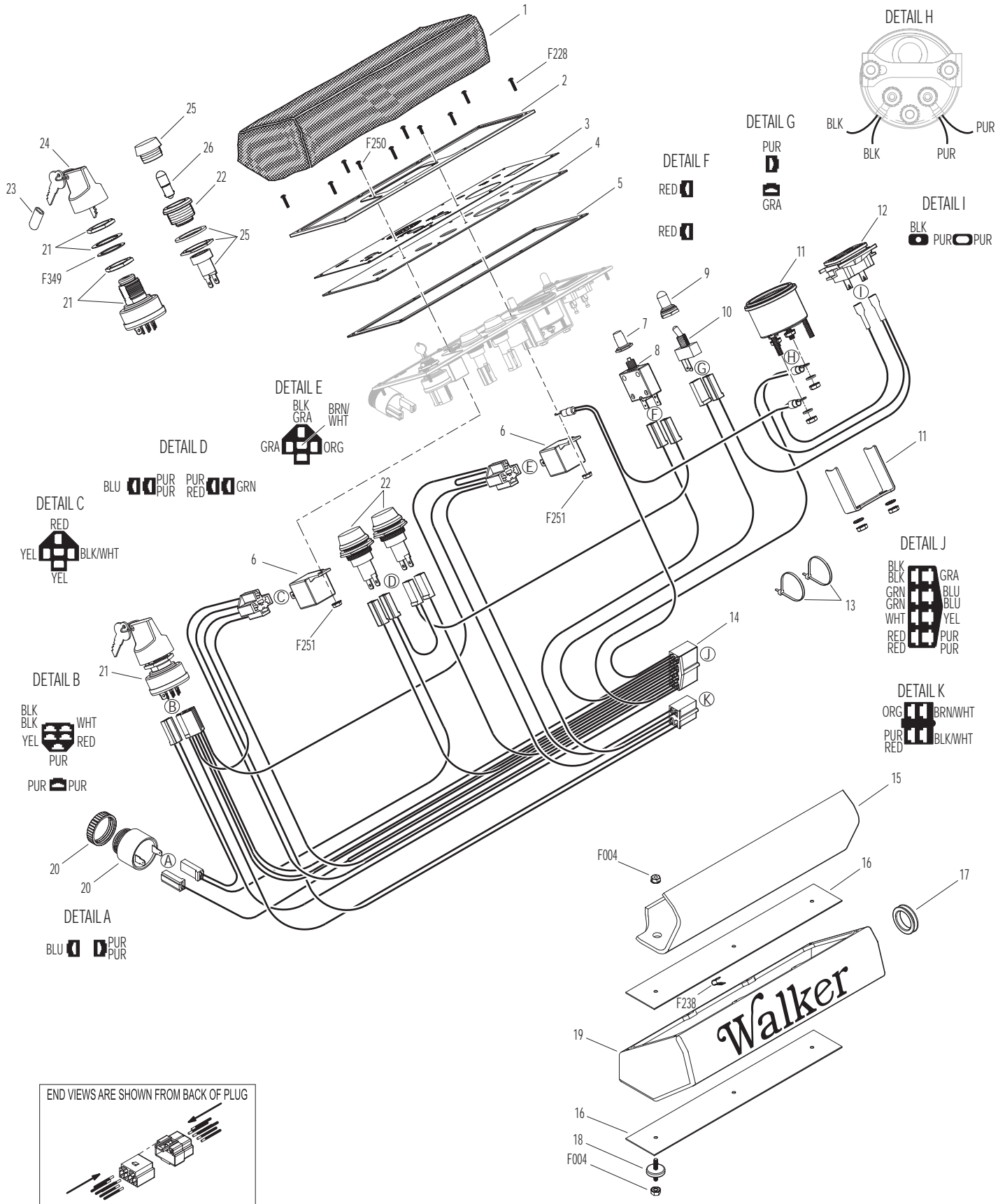

Effective Date 04-01-07

Use only genuine Walker® replacement parts.

INSTRUMENT PANEL ASSEMBLY (MTL)

ITEM NO.	PART NO.	DESCRIPTION	NO. REQ'D	ITEM NO.	PART NO.	DESCRIPTION	NO. REQ'D
Instrument Panel Assembly				20	8960-3	Key Set W/Umbrella	*
1	7307-2	Instrument Panel Cover (Optional)	**	21	7854	Plastic Tip, Red	1
	8306-6	Instrument Panel Assembly (Includes Items # 2-5, 7-20, 28, F025, F228, F250, F251 & F349)	1	22	7307-1	Shock Mount (1.0 x .25)	3
2	7307	Panel Frame	1	23	7391	Panel Box Mount Plate	2
3	8823-4	Decal, Instrument Panel	1	24	8385	Panel Box W/Graphic	1
4	8820-2	Panel Faceplate	1	25	7977-1	Grommet (1/8 x 1-1/16)	1
5	7386	Panel Gasket	1	26	7307-16	Lining 1/8, Panel Box	1
6	8960-15	Ignition Switch (with Keys) (Includes Items # 20, 21 & F349)	1	27	8536	Warning Horn	1
7	8996-2	Red Indicator Light Assembly (Includes Items # 18 & 19)	2	28	6941	Relay Switch (30/40 Amp)	3
8	7941-3	Boot, Circuit Breaker	2	Fasteners			
9	7941-5	Circuit Breaker (7 Amp)	1		F002	10-24 Keps Nut	1
10	7941-2	Circuit Breaker (10 Amp)	1		F004	1/4-20 Keps Nut	6
11	8990-1	Hourmeter (SenDec)	1		F025	10-24 x 3/8 PPHMS	1
12	5995	Toggle Switch (Off-On)	1		F228	#6 x 5/8 PPHSMS, SS	8
13	5995-2	Switch Boot	1		F238	J Clip, Instrument Panel	8
14	7306-14	Water Temperature Gauge	1		F250	6-32 x 1/2 PPHMS	2
15	8997	Voltmeter Gauge	1		F251	6-32 Keps Nut	2
16	8945-4	Wire Harness, Instrument Panel	1		F349	Washer .835 ID, 1.122 OD, SS	1
17	5975-1	Cable Tie (18# x 3-3/4")	2	* Service Part Only			
18	8996-4	Red Indicator Lens	2	** May be ordered as an option. Contact your Walker dealer.			
19	8996-3	Indicator Bulb (Replacement for P/N 8996-2)	*	NOTE: Refer to ELECTRICAL CONNECTORS , Page 64 for identification of all Electrical Wiring Service Parts.			

INSTRUMENT PANEL ASSEMBLY (MTL)

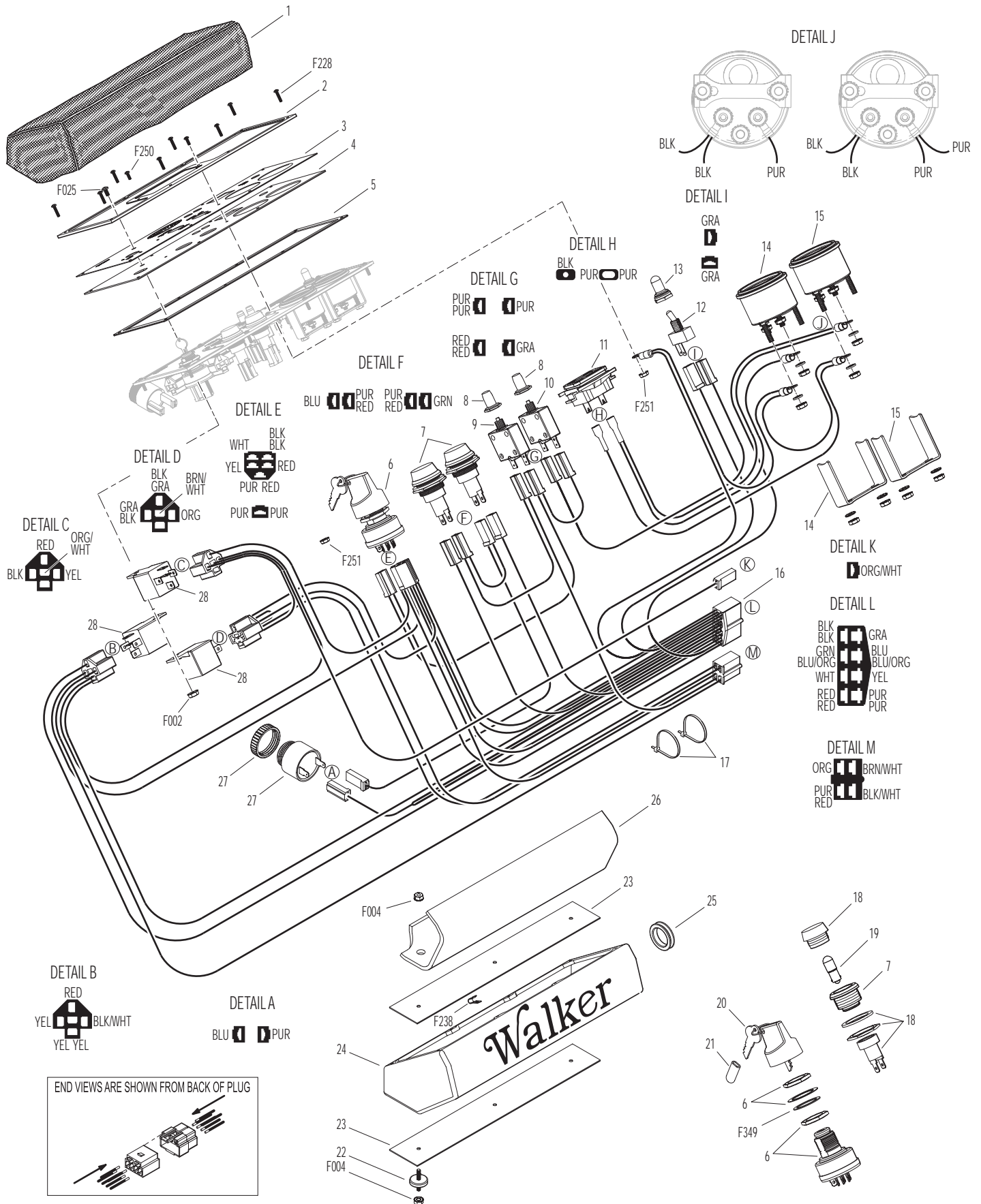

Effective Date 04-01-07

Use only genuine Walker® replacement parts.

INSTRUMENT PANEL ASSEMBLY (MTEFI)

ITEM NO.	PART NO.	DESCRIPTION	NO. REQ'D	ITEM NO.	PART NO.	DESCRIPTION	NO. REQ'D
Instrument Panel Assembly				20	8996-6	Amber Indicator Lens	1
1	7307-2	Instrument Panel Cover (Optional)	**	21	8996-10	Amber Indicator Light Assembly (Includes Items # 16 & 20)	1
	8306-5	Instrument Panel Assembly (Includes Items # 2-12, 14-21, 27, 28, F228, F250, F251 & F349)	1	22	7307-1	Shock Mount (1.0 x .25)	3
2	7307	Panel Frame	1	23	7391	Panel Box Mount Plate	2
3	8823-3	Decal, Instrument Panel	1	24	8385	Panel Box W/Graphic	1
4	8820-16	Panel Faceplate	1	25	7977-1	Grommet (1/8 x 1-1/16)	1
5	7386	Panel Gasket	1	26	7307-16	Lining 1/8, Panel Box	1
6	8996-2	Red Indicator Light Assembly	2	27	8536	Warning Horn	1
7	8990-1	Hourmeter (SenDec)	1	28	8997	Voltmeter Gauge	1
8	5995-2	Switch Boot	1	Fasteners			
9	5995	Toggle Switch (Off-On)	1		F004	1/4-20 Keps Nut	6
10	6941	Relay Switch (30/40 Amp)	2		F228	#6 x 5/8 PPHSMS, SS	8
11	7941-3	Boot, Circuit Breaker	1		F238	J Clip, Instrument Panel	8
12	7941-5	Circuit Breaker (7 Amp)	1		F250	6-32 x 1/2 PPHMS	2
13	5975-1	Cable Tie (18# x 3-3/4")	2		F251	6-32 Keps Nut	2
14	8945-3	Wire Harness, Instrument Panel	1		F349	Washer .835 ID, 1.122 OD, SS	1
15	8996-4	Red Indicator Lens	2	* Service Part Only			
16	8996-3	Indicator Bulb (Replacement for P/N 8996-2)	*	** May be ordered as an option. Contact your Walker dealer.			
17	8960-3	Key Set W/Umbrella	*	NOTE: Refer to ELECTRICAL CONNECTORS , Page 64 for identification of all Electrical Wiring Service Parts.			
18	7854	Plastic Tip, Red	1				
19	8960-15	Ignition Switch (with Keys) (Includes Items # 17, 18 & F349)	1				

INSTRUMENT PANEL ASSEMBLY (MTEFI)

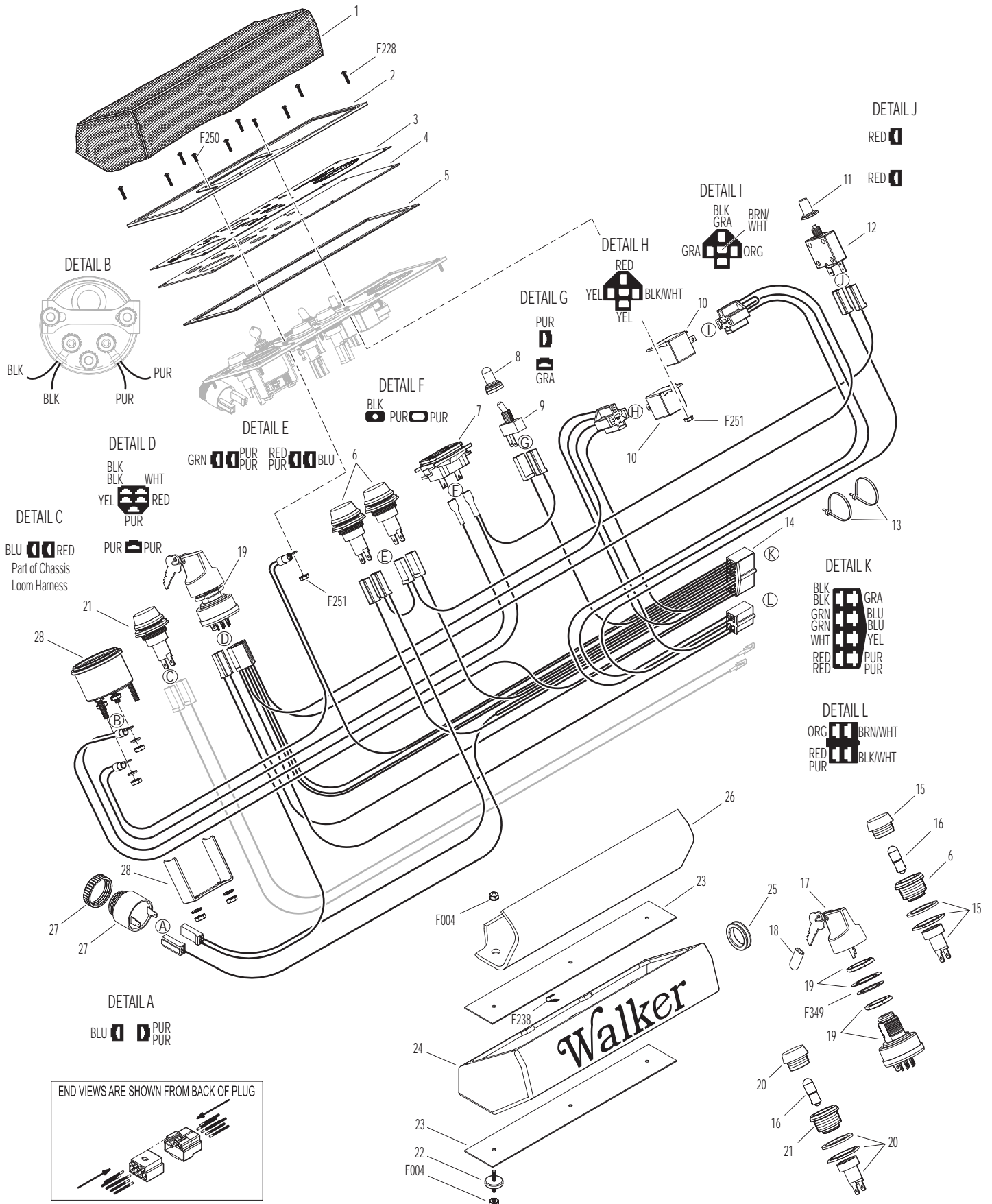

Effective Date 04-01-07

Use only genuine Walker® replacement parts.

INSTRUMENT PANEL ASSEMBLY (MTLEFI)

ITEM NO.	PART NO.	DESCRIPTION	NO. REQ'D	ITEM NO.	PART NO.	DESCRIPTION	NO. REQ'D
Instrument Panel Assembly				21	8996-10	Amber Indicator Light Assembly (Includes Items # 19 & 20)	1
1	7307-2	Instrument Panel Cover (Optional)	**	22	8960-3	Key Set W/Umbrella	*
	8306-7	Instrument Panel Assembly (Includes Items # 2-16, 18-21, 29, 30, F025, F228, F250, F251 & F349)	1	23	7854	Plastic Tip, Red	1
2	7307	Panel Frame	1	24	7307-1	Shock Mount (1.0 x .25)	3
3	8823-5	Decal, Instrument Panel	1	25	7391	Panel Box Mount Plate	2
4	8820-3	Panel Faceplate	1	26	8385	Panel Box W/Graphic	1
5	7386	Panel Gasket	1	27	7977-1	Grommet (1/8 x 1-1/16)	1
6	8960-15	Ignition Switch (with Keys) (Includes Items # 22, 23 & F349)	1	28	7307-16	Lining 1/8, Panel Box	1
7	8996-2	Red Indicator Light Assembly (Includes Items # 18 & 19)	2	29	8536	Warning Horn	1
8	7941-3	Boot, Circuit Breaker	2	30	6941	Relay Switch (30/40 Amp)	3
9	7941-5	Circuit Breaker (7 Amp)	1	Fasteners			
10	7941-2	Circuit Breaker (10 Amp)	1		F002	10-24 Keps Nut	3
11	8990-1	Hourmeter (SenDec)	1		F004	1/4-20 Keps Nut	6
12	5995	Toggle Switch (Off-On)	1		F025	10-24 x 3/8 PPHMS	3
13	5995-2	Switch Boot	1		F228	#6 x 5/8 PPHSMS, SS	8
14	7306-14	Water Temperature Gauge	1		F238	J Clip, Instrument Panel	8
15	8997	Voltmeter Gauge	1		F250	6-32 x 1/2 PPHMS	2
16	8945-5	Wire Harness, Instrument Panel	1		F251	6-32 Keps Nut	2
17	5975-1	Cable Tie (18# x 3-3/4")	2		F349	Washer .835 ID, 1.122 OD, SS	1
18	8996-4	Red Indicator Lens	2	* Service Part Only			
19	8996-3	Indicator Bulb (Replacement for P/N 8996-2)	*	** May be ordered as an option. Contact your Walker dealer.			
20	8996-6	Amber Indicator Lens	1	NOTE: Refer to ELECTRICAL CONNECTORS , Page 64 for identification of all Electrical Wiring Service Parts.			

INSTRUMENT PANEL ASSEMBLY (MTLEFI)

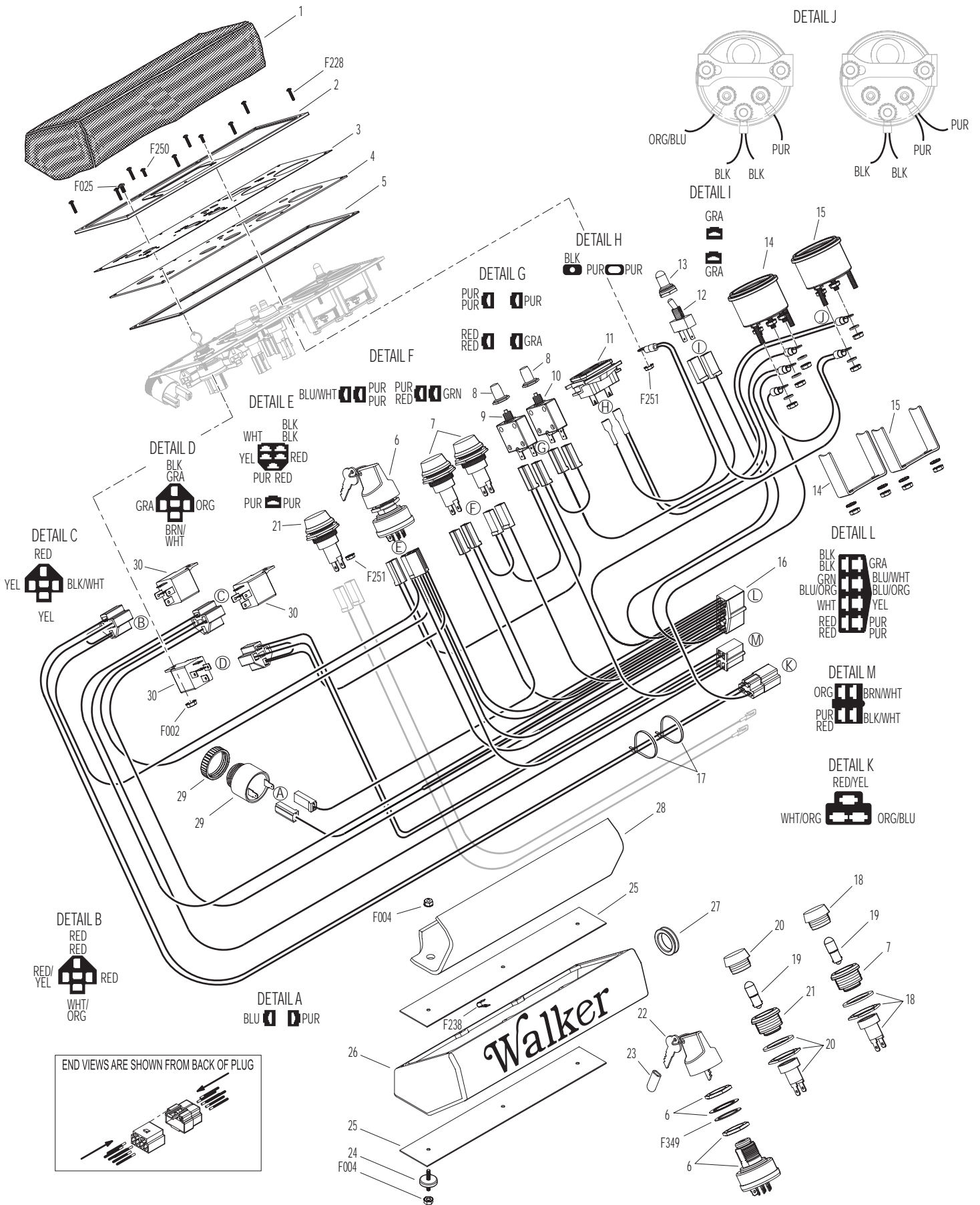

Effective Date 04-01-07

Use only genuine Walker® replacement parts.

ELECTRICAL ASSEMBLY (MT)

ITEM NO.	PART NO.	DESCRIPTION	NO. REQ'D	ITEM NO.	PART NO.	DESCRIPTION	NO. REQ'D
Harness Assembly				Fasteners			
1	5975-3	Cable Tie (50# x 7")	6	F002		10-24 Keps Nut	10
2	5942-4	PTO Safety Switch (Normal Open)	1	F004		1/4-20 Keps Nut	4
3	5833	Cable Clamp (1/4)	1	F009		5/16-18 Whiz Locknut	1
4	8940-3	Wire Harness	1	F019		1/4-20 ESNA Wing Nut	2
5	5832	Cable Clamp (1/2)	5	F025		10-24 x 3/8 PPHMS	4
6	8950	9.5 Wire Harness	1*	F026		10-24 x 1/2 PPHMS	3
	7944	7.0 Wire Harness	1*	F031		1/4-20 x 5/8 Hex Bolt	2
7	7833-2	Cable Clamp (1 x 1/4)	2	F032		1/4-20 x 3/4 Hex Bolt	2
8	6941	Relay Switch (30/40 Amp)	1	F050		1/4 SAE Washer	4
9	7948-1	Time Delay Module	1	F061		1/4 Star Lock Washer	1
10	7948-5	Time Delay Harness	1	F079		A/A66D Aluminum Pop Rivet	4
11	8941	Circuit Breaker (30 Amp) Auto Reset/Sealed	1	F085		3/16 Rivet Backup Washer	1
12	8943	Positive Battery Lead Wire (Red)	1	F093		5/16-18 x 1 Hex Bolt	1
13	5942-5	Safety Switch (Normal Open)	1	F124		10-32 x 3/8 Taptite Machine Screw	2
14	5975-1	Cable Tie (18# x 3-3/4")	3	F129		10-24 x 1/2 PTHMS	1
15	5941-5	Safety Switch (Normal Open)	1	F284		M6 x 1.0 x 8 SCH Screw	1
16	7203-6	Riser Plate, Seat Switch	1				
17	5977-6	Grommet (1 x 1-1/4)	1				
Battery Assembly				* Used on GHS Models with 9.5 Bushel Catcher only. When Optional GHS 7.0 Bushel Catcher is purchased, this part is replaced by P/N 7944 (7.0 Catcher Wire Harness).			
18	6923	Negative Battery Cable	1	NOTE: Refer to ELECTRICAL CONNECTORS , Page 64 for identification of all Electrical Wiring Service Parts.			
19	5933	Battery Terminal Insul., Red (+)	1				
20	5844	Battery Hold-Down Bar	1				
21	5839	Hook Bolt	2				
22	6392	Battery Protector Plate	1				
23	7390-1	Battery Pan	1				
24	7910	Battery (12V/340CCA/Dry)	1				
25	5932	Battery Terminal Insul., Black (-)	1				
26	7834-2	Wire Saddle (2 Wires)	1				

ELECTRICAL ASSEMBLY (MT)

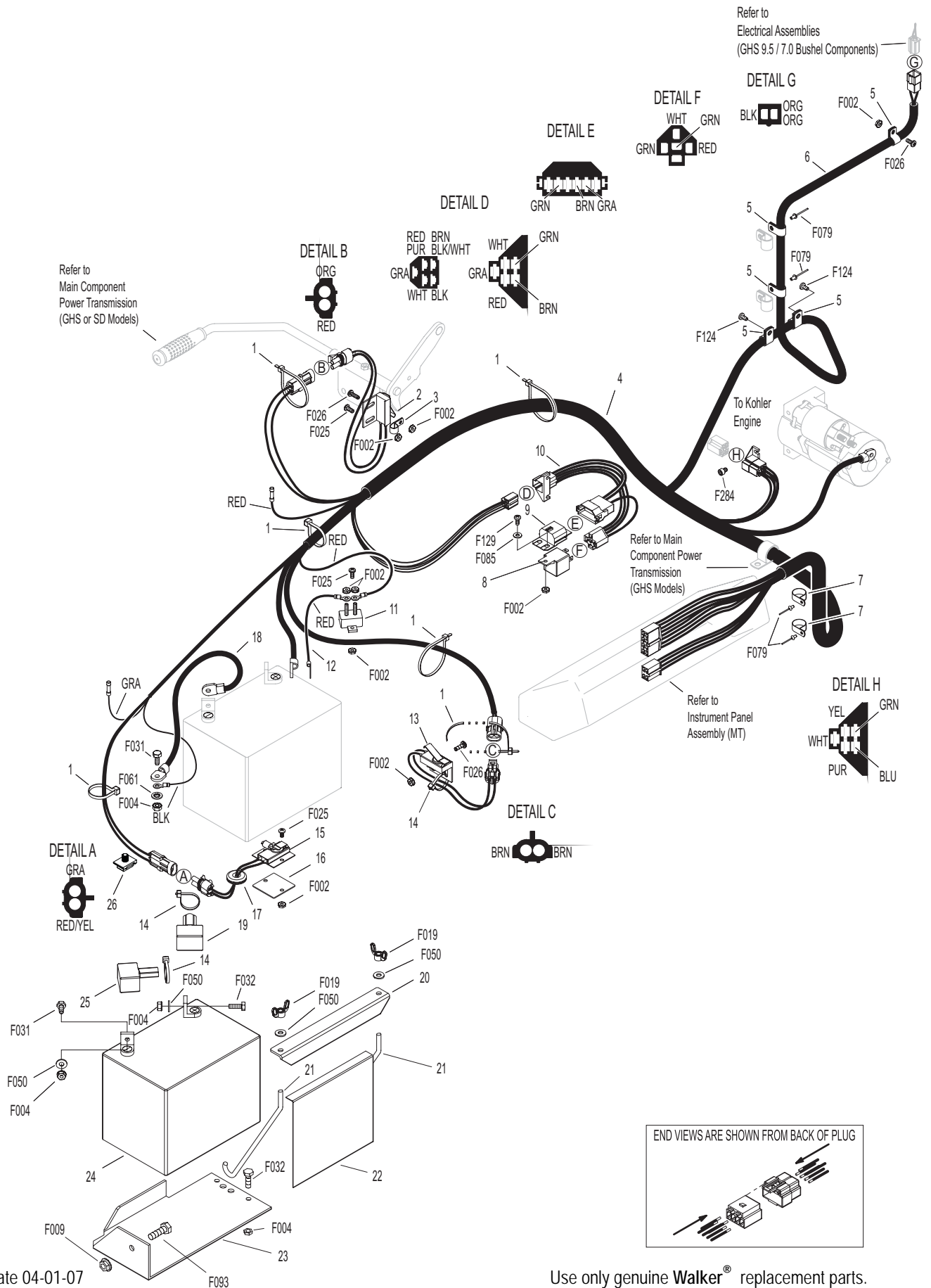

Effective Date 04-01-07

Use only genuine Walker® replacement parts.

ELECTRICAL ASSEMBLY (MTL)

ITEM NO.	PART NO.	DESCRIPTION	NO. REQ'D	ITEM NO.	PART NO.	DESCRIPTION	NO. REQ'D
Electrical Assembly				Fasteners			
1	8012-7	Ground Wire	1		F002	10-24 Keps Nut	7
2	8012-5	Regulator Adapter Harness	1		F004	1/4-20 Keps Nut	1
3	7428-1	Fan Control Module W/P Plug	1		F025	10-24 x 3/8 PPHMS	2
4	7958-3	Washer (.209 ID x .620 OD)	2		F027	10-24 x 5/8 PPHMS	2
5	8941	Circuit Breaker (30 Amp) Auto Reset/Sealed	1		F050	1/4 SAE Washer	1
6	6941	Relay Switch (30/40 Amp)	1		F061	1/4 Star Washer	1
7	5975-1	Cable Tie (18# x 3-3/4")	3		F090	1/4-20 x 2-1/2 Hex Bolt	1
8	7306-10	Switch (235 Deg., 1/4-18 NPT)	1		F116	1/4-20 x 1-1/4 Hex Bolt	1
9	7306-11	Switch (205 Deg., 3/8-18 NPT)	1		F182	1/4 x 5/8 x 1/8 Washer	1
10	5975-7	Cable Tie (50# x 11")	1		F188	1/4-20 Self-Locking Nut	1
11	7433	Resistor, Ceramic / .4 OHM	1	NOTE: Refer to ELECTRICAL CONNECTORS , Page 64 for identification of all Electrical Wiring Service Parts.			
12	6103-19	Adapter Harness	1				
13	8940-4	Wiring Harness	1				
14	5975-3	Cable Tie (50# x 7")	1				

ELECTRICAL ASSEMBLY (MTL)

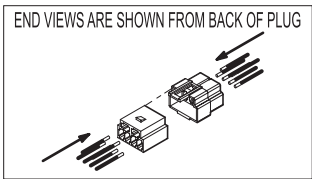
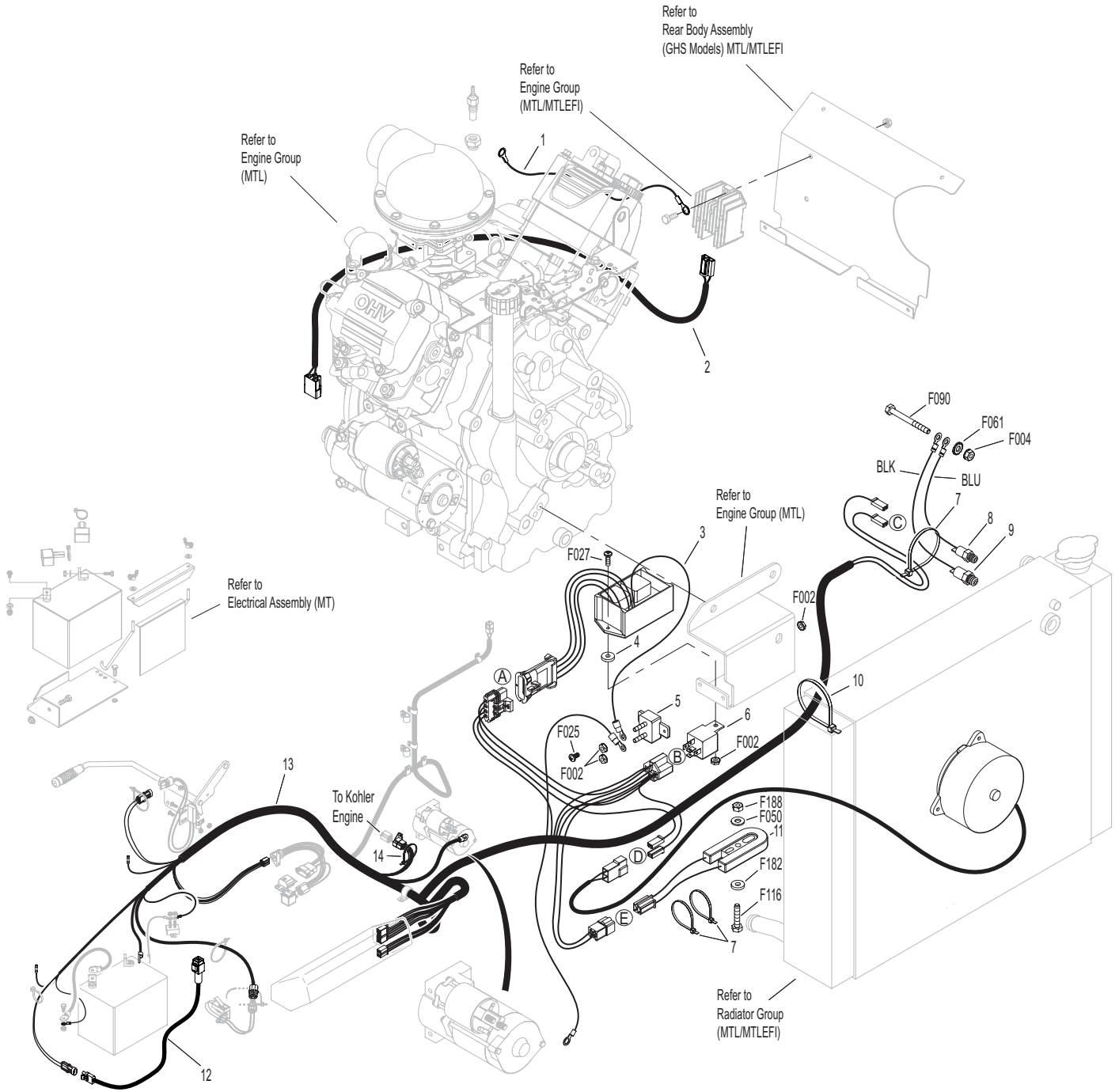

DETAIL A



DETAIL B



DETAIL C



DETAIL D



DETAIL E



ELECTRICAL ASSEMBLY (MTEFI)

ITEM NO.	PART NO.	DESCRIPTION	NO. REQ'D	ITEM NO.	PART NO.	DESCRIPTION	NO. REQ'D
Electrical Assembly				Fasteners			
1	8940-16	Wire Harness, Ext. Fuel Pump	1	F002		10-24 Keps Nut	2
2	5975-1	Cable Tie (18# x 3-3/4")	1	F063		3/8 Internal Star Lock Washer	1
3	NS	Fuse Holder (Kohler)	3	F103		10-24 x 2 PTHMS	1
4	6941-4	30 Amp Fuse	1	F106		3/8-16 x 5/8 Hex Bolt	1
5	NS	Relay (Kohler)	1	F284		M6 x 1.0 x 8 SHC Screw	1
6	6941-1	20 Amp Fuse	1	F361		10-24 x 2-1/2 Hex Bolt	1
7	6941-3	10 Amp Fuse	1				
8	NS	ECU Harness Clip	1				
9	NS	ECU (Kohler)	1				
10	5975-8	Cable Tie (50# x 17-1/2")	1				

NOTE: Refer to **ELECTRICAL CONNECTORS**, Page 64 for identification of all Electrical Wiring Service Parts.

ELECTRICAL ASSEMBLY (MTEFI)

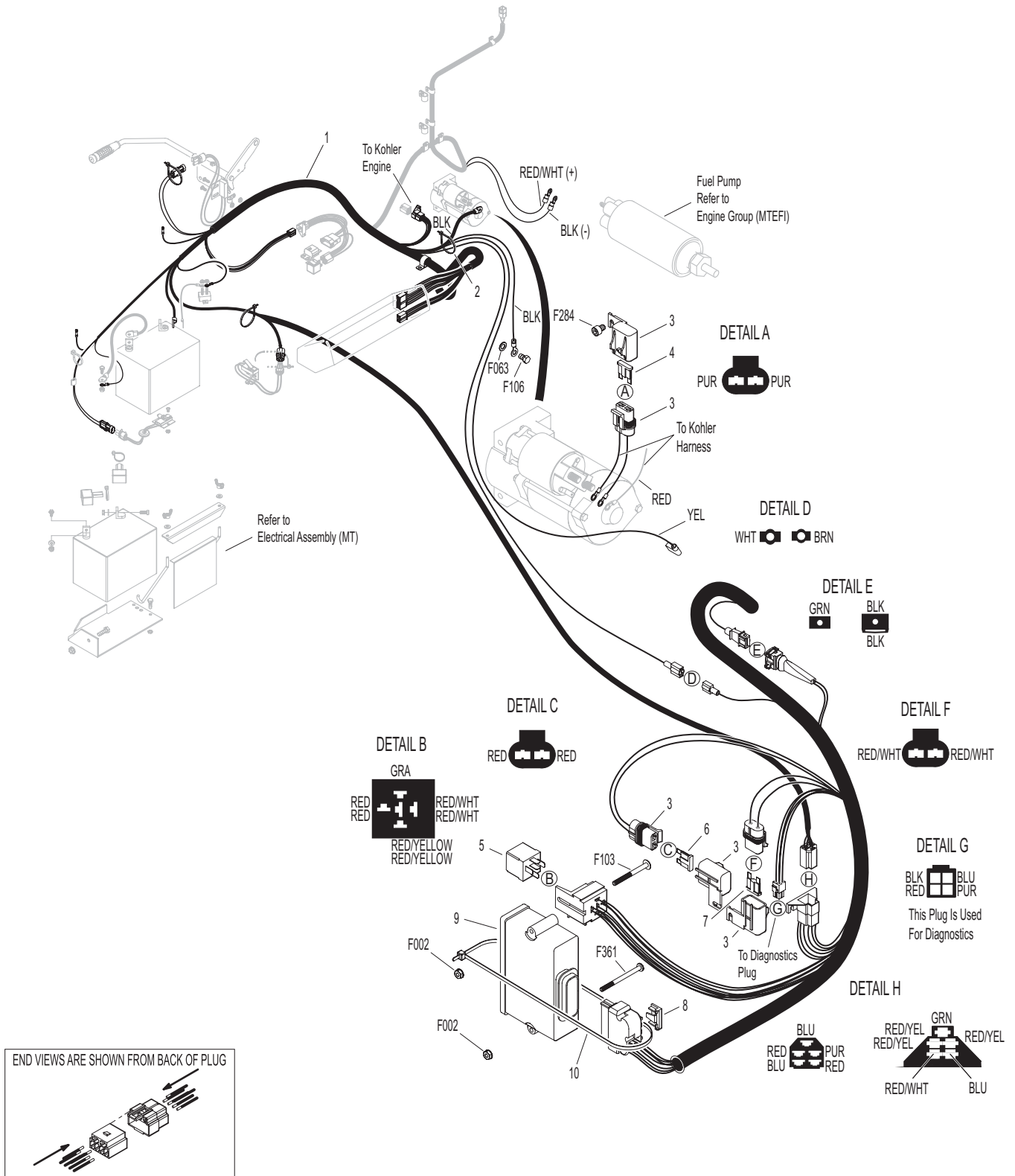

ELECTRICAL ASSEMBLY (MTLEFI)

ITEM NO.	PART NO.	DESCRIPTION	NO. REQ'D	ITEM NO.	PART NO.	DESCRIPTION	NO. REQ'D
Electrical Assembly				Fasteners			
1	8012-7	Ground Wire	1	F002		10-24 Keps Nut	7
2	8012-6	Regulator Adapter Harness	1	F004		1/4-20 Keps Nut	1
3	7428-1	Fan Control Module W/P Plug	1	F025		10-24 x 3/8 PPHMS	3
4	7958-3	Washer (.209 ID x .620 OD)	2	F027		10-24 x 5/8 PPHMS	2
5	7941	Circuit Breaker 40 Amp (Auto Reset/Sealed)	1	F050		1/4 SAE Washer	1
6	6941	Relay Switch (30/40 Amp)	1	F061		1/4 Star Washer	1
7	5975-1	Cable Tie (18# x 3-3/4")	4	F063		3/8 Internal Star Lock Washer	1
8	7427-12	Brass Pipe Plug (1/4 NPTF)	1	F090		1/4-20 x 2-1/2 Hex Bolt	1
9	7306-11	Switch (205 Deg., 3/8-18 NPT)	1	F102		10-24 x 1-1/2 PTHMS	2
10	5975-7	Cable Tie (50# x 11")	1	F103		10-24 x 2 PTHMS	1
11	7433	Resistor, Ceramic / .4 OHM	1	F106		3/8-16 x 5/8 Hex Bolt	1
12	NS	Fuse Holder (Kohler)	3	F116		1/4-20 x 1-1/4 Hex Bolt	1
13	6941-4	30 Amp Fuse	1	F182		1/4 x 5/8 x 1/8 Washer	1
14	NS	ECU Harness Clip	1	F188		1/4-20 Self-Locking Nut	1
15	NS	Relay (Kohler)	1	F195		1/4-20 x 3/4 PPHMS, SS	1
16	6941-3	10 Amp Fuse	1	F284		M6 x 1.0 x 8 SHC Screw	1
17	6941-1	20 Amp Fuse	1				
18	8940-7	ECU Mount Plate	1				
19	NS	ECU (Kohler)	1				
20	6103-19	Adapter Harness	1				
21	8940-6	Wiring Harness	1				

NOTE: Refer to **ELECTRICAL CONNECTORS**, Page 64 for identification of all Electrical Wiring Service Parts.

ELECTRICAL ASSEMBLY (MTLEFI)

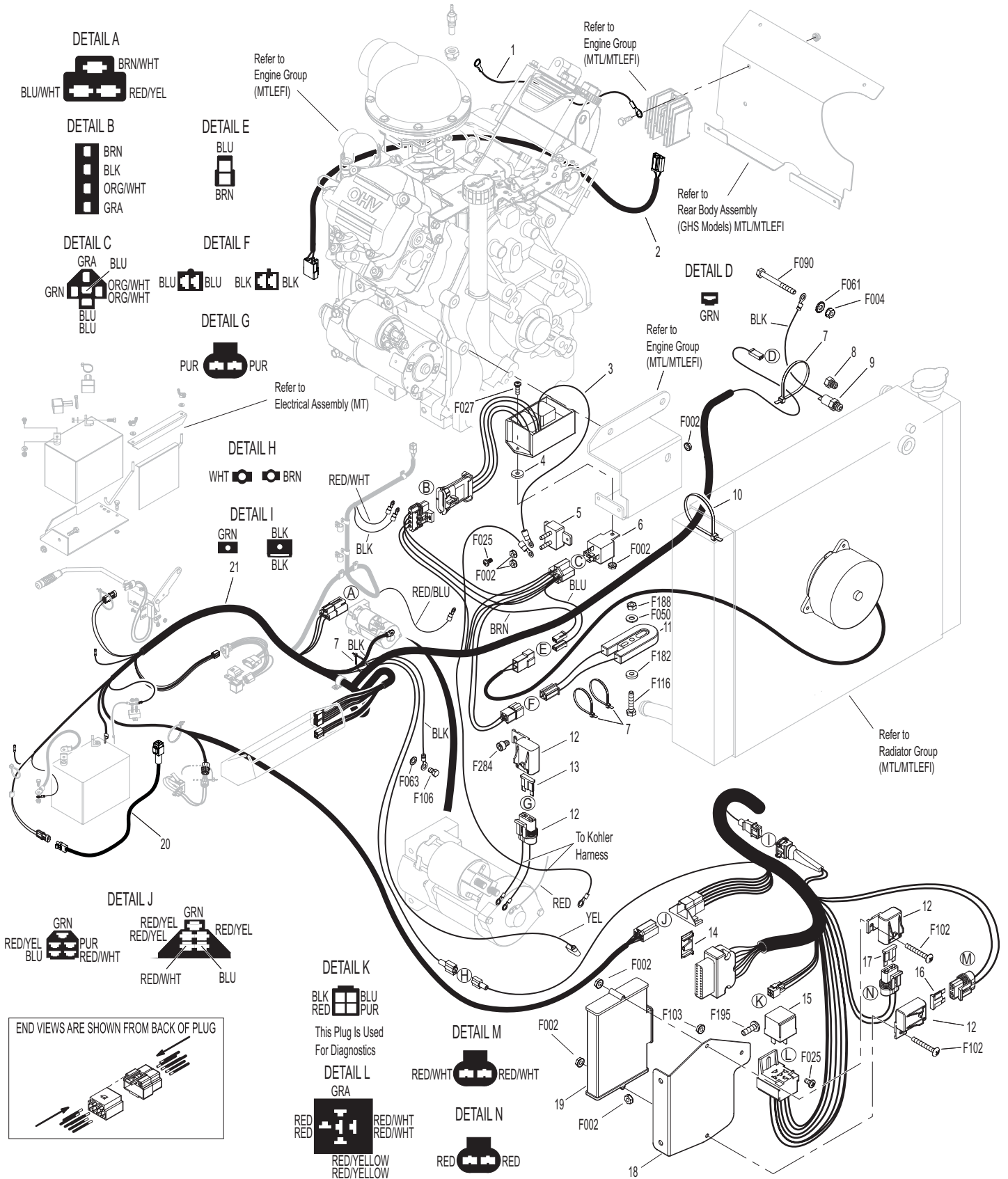

Effective Date 04-01-07

Use only genuine Walker® replacement parts.

ELECTRICAL ASSEMBLIES (GHS 9.5 / 7.0 BUSHEL COMPONENTS)

ITEM NO.	PART NO.	DESCRIPTION	NO. REQ'D
----------	----------	-------------	-----------

Horn & Harness Channel Assemblies

1	5975-3	Cable Tie (50# x 7")	2
2	5536-2	Horn, Full Signal	*

Harness & Grass-Pak® Switch Assemblies

3	7835	Frame Clip (3/16)	6
4	8950	9.5 Wire Harness	1
	7944	7.0 Wire Harness	*
5	5833	Cable Clamp (1/4)	2
6	5980-3	Wire, Grass-Pak® Switch	1
7	5592-11	Liquid Tight Plug	1
8	5592-10	Grass-Pak® Switch Module	1
	5592-4	Grass-Pak® Switch Assembly (Includes Items # 6, 7 & 8)	*
9	5594-5	Vane Assembly, Grass-Pak® Switch (Includes Items # F144 & F145)	1
10	5977-2	Grommet, Cut (1/8 x 3/8)	1

ITEM NO.	PART NO.	DESCRIPTION	NO. REQ'D
----------	----------	-------------	-----------

Fasteners

F002	10-24 Keps Nut	5
F025	10-24 x 3/8 PPHMS	1
F037	10-24 x 5/8 PTH Screw	2
F129	10-24 x 1/2 PTHMS	2
F144	4-40 x 1/4 PPHMS	1
F145	4-40 Keps Nut	1

* Service Part Only

NOTE: Refer to **ELECTRICAL CONNECTORS**, Page 64 for identification of all Electrical Wiring Service Parts.

ELECTRICAL ASSEMBLIES (GHS 9.5 / 7.0 BUSHEL COMPONENTS)

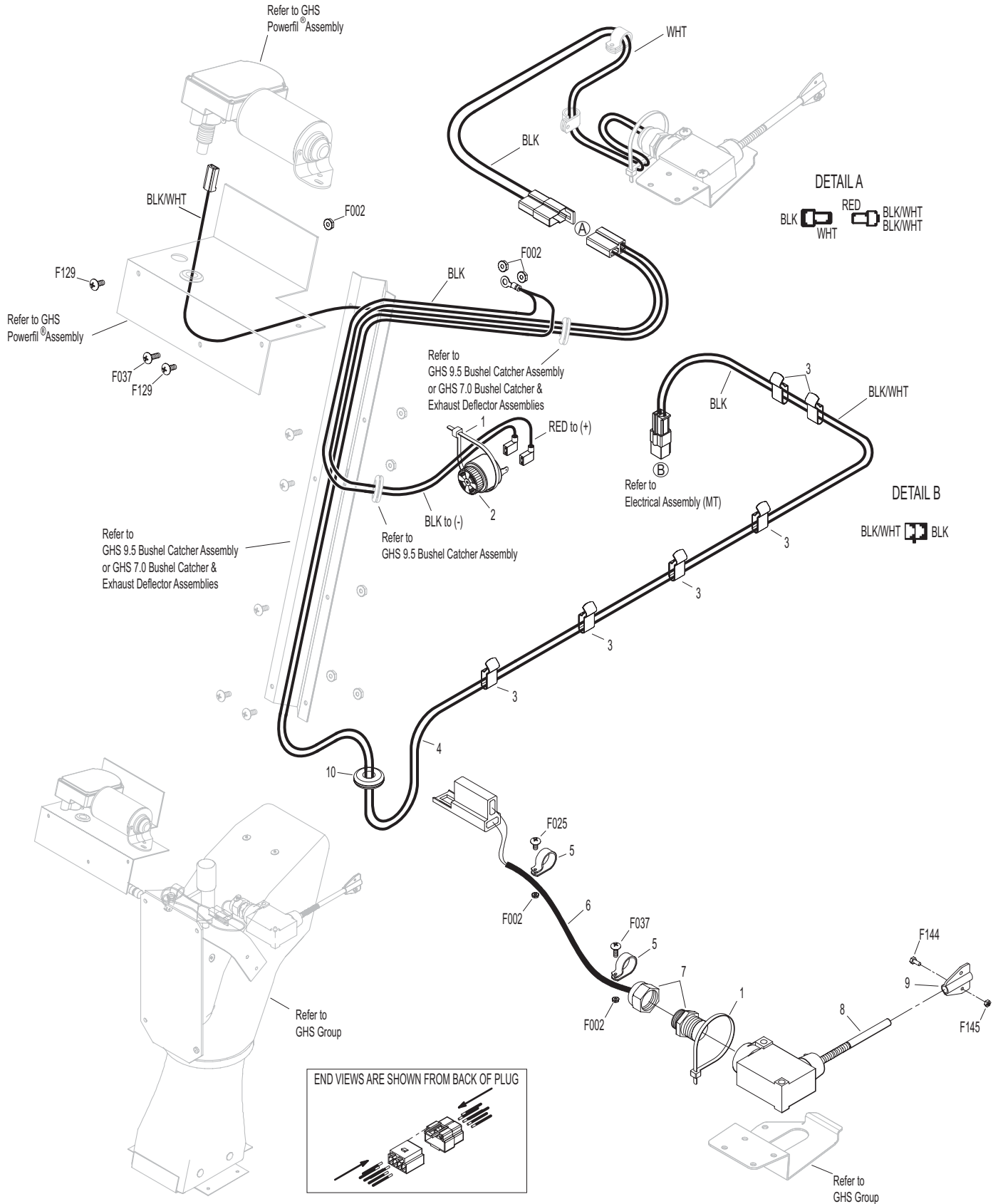

ELECTRICAL CONNECTORS

ITEM NO.	PART NO.	DESCRIPTION	NO. REQ'D	ITEM NO.	PART NO.	DESCRIPTION	NO. REQ'D
Electrical Wiring Service Parts				29	7942-1	2-Way Locking Connector, Female	*
1	5996-1	16-14 GA Butt Connector	*	30	7942-2	2-Way Connector, Male	*
2	5996-11	12-10 GA Butt Connector	*	31	7942-3	2-Way Connector, Female	*
3	7942-14	16-14 GA Shrink Connector	*	32	7942-10	2-Way Locking Connector, Male	*
4	7942-13	12-10 GA Shrink Connector	*	33	5940-8	3-Way Connector, Male	*
5	5995-1	Wire Terminal Adapter	*	34	7942-9	3-Way Connector, Male	*
6	5996-4	16-14 GA Bullet Conn., Male	*	35	8944	3-Way Locking Connector, Male	*
7	5996-5	16-14 GA Bullet Conn., Female	*	36	8944-1	3-Way Locking Connector, Female	*
8	5940-4	16-14 GA Spg. Loaded Term., Female	*	37	7942-11	4-Way Connector, Male	*
9	5940-7	Wire Clip, Female	*	38	7942-12	4-Way Connector, Female	*
10	5996	1/4 x 16-14 GA QKS Term., Female	*	39	7942-5	5-Way Connector, Male	*
11	5996-2	3/16 x 22-18 GA QKS Term., Female	*	40	5940-2	5-Way Connector, Male	*
12	7996	16-14 GA QKS Term., Female	*	41	8942-1	5-Way Connector, Female	*
13	5940-5	16-14 GA Spg. Loaded Term., Male	*	42	7942-6	6-Way Connector, Male	*
14	5996-0	1/4 x 22-18 GA QKS Term., Male	*	43	7942-7	6-Way Connector, Male	*
15	5996-18	16-14 GA Ring Term. (#8) Nylon Insulated	*	44	7942-8	8-Way Connector, Male	*
16	7996-1	1/4 x 16-14 GA QKS Term., Male	*	45	8942-2	8-Way Connector, Female	*
17	5996-8	6 GA Ring Lug (5/16)	*	46	8942-3	5-Way Connector, Male	*
18	5996-9	22-18 GA Ring Term., #10	*	47	5940-9	3-Way Connector (M)	*
19	5996-10	16-14 GA Ring Term. (5/16)	*	48	7942-15	6-Way Connector (Female)	*
20	5996-12	12-10 GA Ring Term. (5/16)	*	49	7940-3	Packard Plug (Male)	*
21	5996-13	16-14 GA Ring Term., # 10	*	50	7940-4	Packard Plug (Female)	*
22	5996-15	12-10 GA Ring Term. (1/2)	*	* Service Part Only			
23	5996-16	6 GA Ring Terminal (1/4)	*	NOTE: Not all Electrical Connectors are used with all assemblies.			
24	5996-17	16-14 GA Ring Term. (1/4)	*	NOTE: Refer to ELECTRICAL ASSEMBLY , Page 54 for locations of Wiring Harness and of all Electrical Wiring Service Parts.			
25	5996-20	12-10 GA Ring Term. (1/4)	*				
26	5996-21	12-10 GA Ring Term., #10	*				
27	7942-4	Single Connector, Male	*				
28	8942	2-Way Connector, Male	*				

ELECTRICAL CONNECTORS

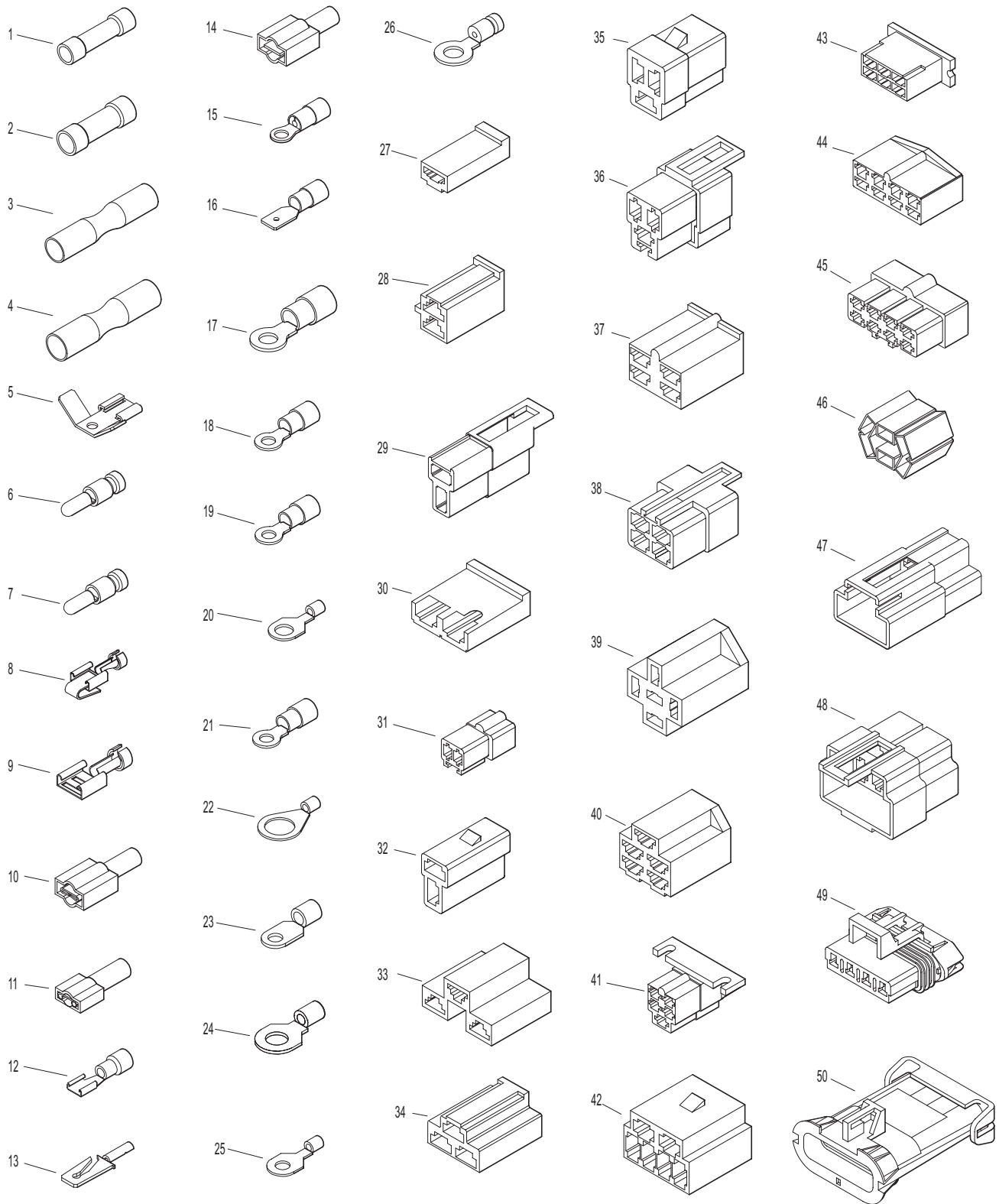

POWER DECK LIFT KIT

ITEM NO.	PART NO.	DESCRIPTION	NO. REQ'D
Kit	8655	Power Deck Lift Option / Kit	
Includes Items # 1-31, fasteners listed and instructions. May be ordered as a dealer-installed option. Contact your Walker dealer.			
1	8628	Linear Actuator (Includes Items # 29, 30 & F320)	1
2	8655-8	Clamp Bar	1
3	7503-10	Actuator Drive Bushing	1
4	8655-10	Bushing (5/8 x 5/16 x 1-1/16)	1
5	8655-11	Bushing (5/8 x 5/16 x 1-1/16)	1
6	8655-7	Arm, Deck Lift	1
7	8655-12	Bushing (3/4 x 1/4 ID x 3/4)	1
8	5977-1	Grommet (1/8 x 3/8)	1
9	8649	Wire Harness	1
10	5975-5	Wire Clip, Self Mount	1
11	5996-20	12-10 GA Ring Terminal (1/4)	*
12	5940-4	16-14 GA Spring-Loaded Terminal (F)	*
13	8942-3	5-Way Connector (M)	1
14	6623	Toggle Switch	1
15	5996-21	12-10 GA Ring Terminal (# 10)	*
16	8655-5	Cable Mount	2
17	8655-1	Hitch Pin/Cotterless (5/8)	2
18	8655-6	Lift Chain	2
19	8655-3	Cable LH (48")	1
20	8654	Decal, Deck Lift	1
21	6623-1	Switch Boot	1
22	8655-2	Cable RH (38.5")	1
23	6832	Cable Clamp (9/16 x 1/4)	1
24	5832	Cable Clamp (1/2)	1
25	8655-9	Cable Pull	1
26	8655-22	Base, Deck Lift	1
27	8655-4	Clevis Pin (5/16 x 3/4)	2
28	5975-3	Cable Tie (#50 x 7")	3
29	7942-1	2-Way Locking Connector (F)	*
30	5940-5	16-14 GA Spring-Loaded Terminal (M)	*
31	7942-10	2-Way Locking Connector (M)	*

ITEM NO.	PART NO.	DESCRIPTION	NO. REQ'D
Fasteners			
	F002	10-24 Keps Nut	1
	F004	1/4-20 Keps Nut	11
	F009	5/16-18 Whiz Locknut	6
	F025	10-24 x 3/8 PPHMS	1
	F029	1/4-20 x 1/2 Hex Bolt	8
	F032	1/4-20 x 3/4 Hex Bolt	1
	F050	1/4 SAE Washer	1
	F061	1/4 Star Lock Washer	1
	F068	1/8 x 1 Cotter Pin	1
	F069	3/32 x 1/2 Cotter Pin	2
	F093	5/16-18 x 1 Hex Bolt	2
	F134	AN960816L Washer	1
	F179	1/4-20 x 1 Hex Bolt	1
	F316	5/16-18 x 1-3/4 Hex Bolt	2
	F320	1/8 x 3/4 Split Spring Pin	*

* Service Part Only

NOTE: Power Deck Lift is not compatible with Comfort Seat or Suspension Seat.

POWER DECK LIFT KIT

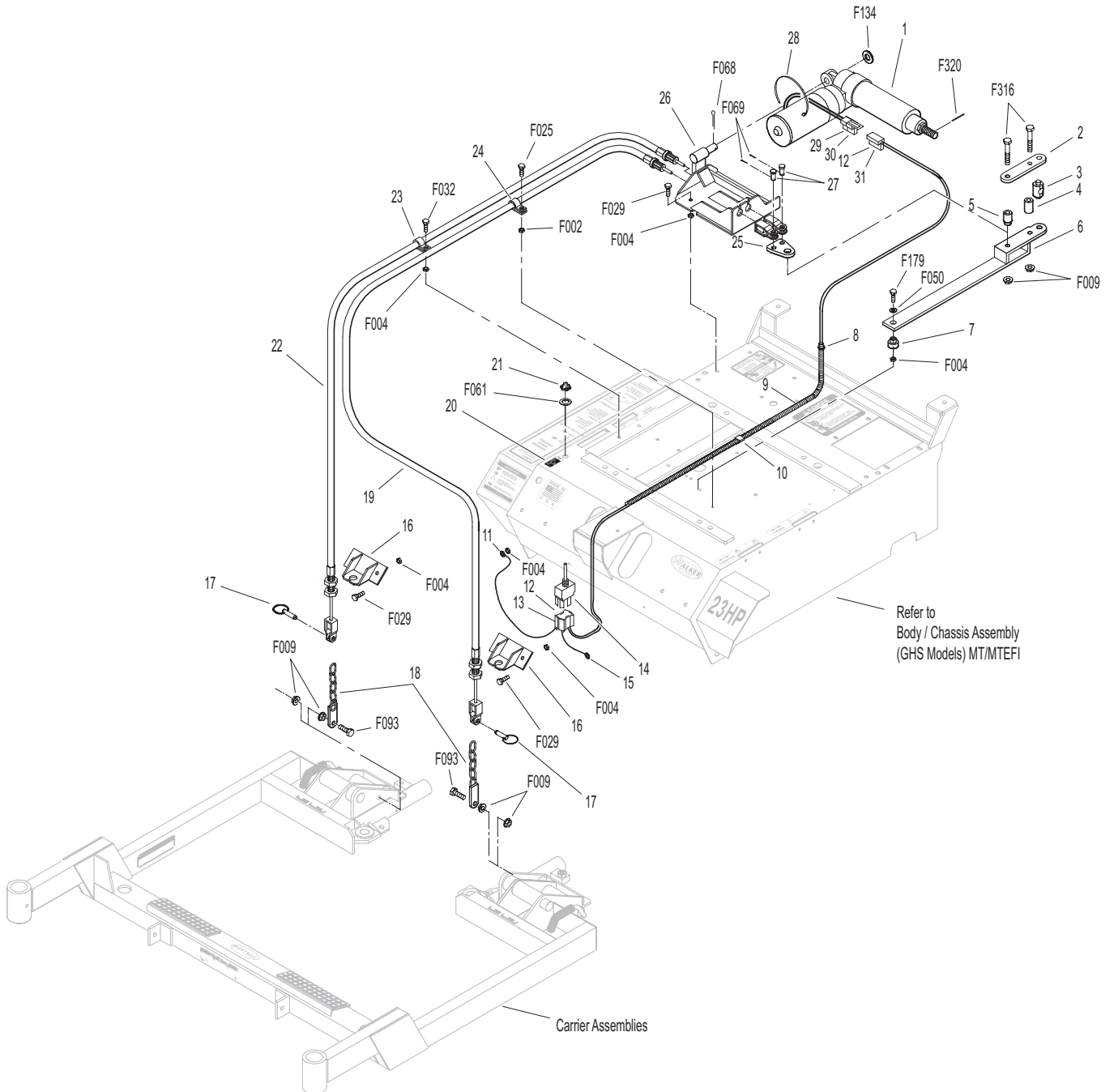

ARMREST KIT / TOUCH-UP PAINT / COMFORT SEAT KIT

ITEM NO.	PART NO.	DESCRIPTION	NO. REQ'D
----------	----------	-------------	-----------

Kit 5885 Armrest Option / Kit

Includes Items # 1-5, fasteners listed and instructions. May be ordered as a dealer-installed option. Contact your Walker dealer.

1	5886-1	Armrest, RH	1
2	5886-6	Cover Plate, RH	1
3	5887	Mounting Bracket	1
4	5886-5	Cover Plate, LH	1
5	5886-2	Armrest, LH	1
	5888	Armrest Hardware Kit (Includes Items # F305, F306, F307 & F308)	*

Touch-Up Paint

6	5866	Touch-Up Paint, Yellow (12 oz. Aerosol)	
7	5867	Touch-Up Paint, Grey (12 oz. Aerosol)	

Kit 6103-5 Comfort Seat Kit (Cordura)

Includes Items # 8, 13, fasteners listed and instructions. May be ordered as a dealer-installed option. Contact your Walker dealer.

8	6103-5	Comfort Seat	1
9	7203	Seat Spring Plate	**
10	7223-1	Compression Spring	**
11	7846	Rubber Washer (3/8 x 1-1/4 x 1/8)	**
12	7204	Shoulder Bolt, Seat Mount	**
13	7203-6	Riser Plate, Seat Switch	***
14	7845	Rubber Bumper (1.375 x .63)	**
15	7440-5	Shock Mount (1-1/4 x 3/4)	**

ITEM NO.	PART NO.	DESCRIPTION	NO. REQ'D
----------	----------	-------------	-----------

Kit 6103-17 Armrest Option / Kit

Includes Items # 16, 17 and instructions. Item # 16 is the **Right** side armrest only. Item # 17 is the **Left** side armrest only. Sold only as a complete set and may be ordered together as a factory-installed option or as a kit for dealer installation. Contact your Walker dealer.

16	6103-42	Armrest, RH/Cordura	1
17	6103-41	Armrest, LH/Cordura	1

Fasteners

F009	5/16-18 Whiz Locknut	**
F026	10-24 x 1/2 PPHMS	2
F227	3/8 x 1-1/4 x 1/8 Plastic Washer	**
F305	1/4-20 x 3/8 SH Cap Screw	2
F306	3/8-16 x 3/4 Hex Bolt	4
F307	#10 x 5/8 PPHST Screw	2
F308	1-1/4 x 1-5/8 Wave Spring Washer	2

* Service Part Only

** Reuse existing parts from Seat Assembly. Refer to **BODY / CHASSIS ASSEMBLY (GHS MODELS) MT/MTEFI**, Page 4.

*** Only one Riser Plate is included with kit. One is reused from Seat Assembly. Refer to **BODY / CHASSIS ASSEMBLY (GHS MODELS) MT/MTEFI**, Page 4.

ARMREST KIT / TOUCH-UP PAINT / COMFORT SEAT KIT

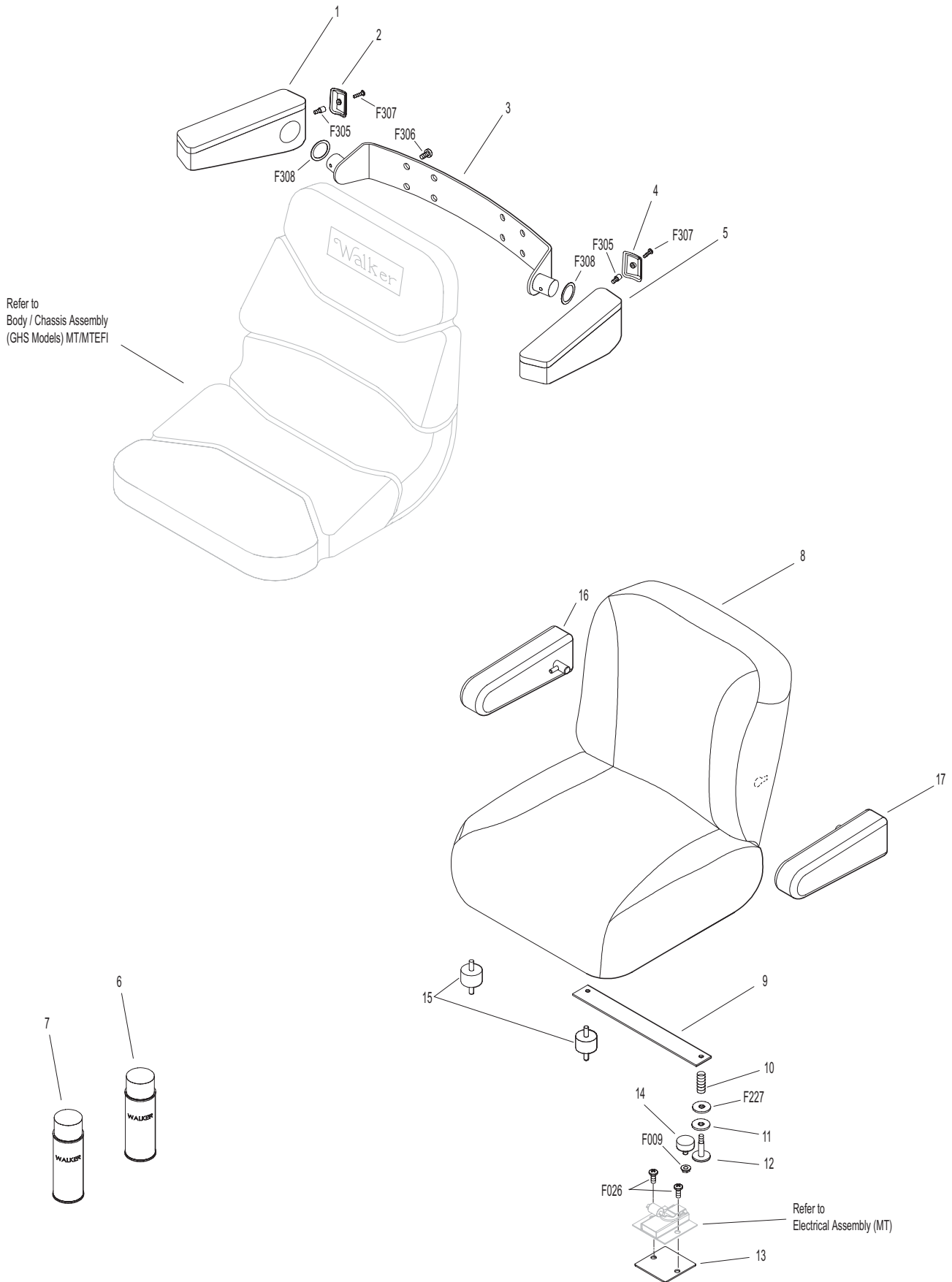

Effective Date 04-01-07

Use only genuine Walker® replacement parts.

SUSPENSION SEAT KIT

ITEM NO.	PART NO.	DESCRIPTION	NO. REQ'D	ITEM NO.	PART NO.	DESCRIPTION	NO. REQ'D
Kit 6103-24 Suspension Seat Option / Kit Includes Items # 1-9, fasteners listed and instructions. May be ordered as a factory-installed option or as a kit for dealer installation. Contact your Walker dealer.				Fasteners			
1	6103-14	Suspension Seat	1	F002	10-24 Keps Nut		1
2	6103-35	Suspension Seat Mount	2	F009	5/16-18 Whiz Locknut		8
3	7440-7	Shock Mount	4	F025	10-24 x 3/8 PPHMS		1
4	6105-1	Shoulder Washer	2	F091	5/16-18 x 5/8 Hex Bolt		4
5	6103-19	Adapter Harness	1*	F188	1/4-20 Self-Locking Nut		4
6	6105-3	Harness Clip	2	F198	.250 x .625 x .040 Washer, SS		2
7	5977-3	Grommet (9/16)	1	F345	1/4-20 x .770 Knurled Bolt		4
8	5453-20	Steering Lever Handle +1" Adj. / SS	2	F429	5/16-18 x 1/2 SFH Screw		4
9	7833-2	Cable Clamp (1 x 1/4)	1	* Remove existing Seat Switch. Plug Harness into Seat Harness.			

SUSPENSION SEAT KIT

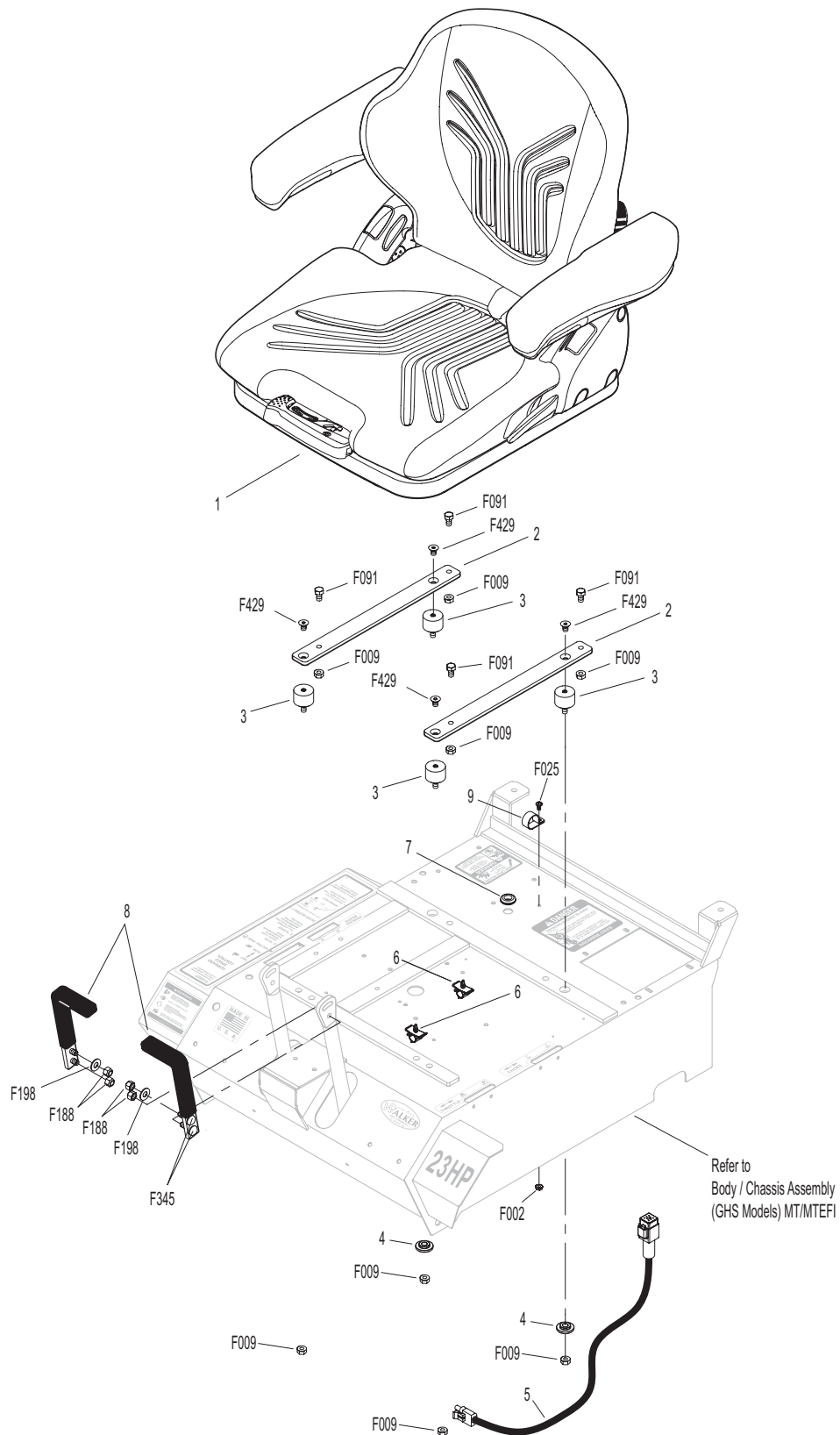

LIGHT KIT / COLD START KIT / SPEED UP KIT

ITEM NO.	PART NO.	DESCRIPTION	NO. REQ'D
----------	----------	-------------	-----------

Kit 7989-11 Light Option / Kit

Includes Items # 1-10, fasteners listed and instructions. May be ordered as a dealer-installed option. Contact your Walker dealer.

1	7989-2	Light Assembly (Halogen) (Includes Items # 2 & 4) (Includes Halogen Bulb)	2
	7989-6	Bulb Replacement (Halogen)	*
2	7989-3	Wire Harness Extension	2
3	7834-2	Wire Saddle (2 Wires)	8
4	5996-4	16-14 GA Bullet Cntr. (M)	3
5	5996-5	16-14 GA Bullet Cntr. (F)	2
6	7993-1	Mount Bracket, Lights	1
7	7995-3	Power Lead Wire Assembly (Includes Items # 4, 5, 8, 9 & 10)	1
8	5977-1	Grommet (1/8 x 3/8)	2
9	5975-1	Cable Tie (18# x 3-3/4")	1
10	5996	1/4 x 16-14 GA QDF Terminal	1

Kit 8638 Cold Start Option / Kit

Includes Items # 11-13, fasteners F004, F029, and instructions.

11	5830	Grease Fitting	1
12	7406-1	Handle Grip, Red	1
13	8638-1	Idler Release (Includes Items # 11 & 12)	1

ITEM NO.	PART NO.	DESCRIPTION	NO. REQ'D
----------	----------	-------------	-----------

Kit 8247 Speed-Up Option / Kit

Includes Items # 14, 15 and instructions.

14	5224	Extension Spring (1 x 4)	1
15	7240-1	Jackshaft Drive Pulley (3-1/2/3V) (Includes Items # F067 & F171)	1

Both kits may be ordered as a dealer-installed option. Contact your Walker dealer.

Fasteners

F004	1/4-20 Keps Nut	2
F009	5/16-18 Whiz Locknut	2
F029	1/4-20 x 1/2 Hex Bolt	2
F052	5/16 Ext. Star Lock Washer	2
F067	3/16 x 3/16 x 1 Key	1
F091	5/16-18 x 5/8 Hex Bolt	2
F171	5/16-18 x 3/8 Set Screw	*

* Service Part Only

NOTE: Upon installation of kit, Item # 8 replaces P/N 5989-4 (Dome Plug, 3/8) and Item # F091 replaces P/N 5989-3 (Dome Plug, 5/16). Dome Plugs are not shown here. Refer to **BODY / CHASSIS ASSEMBLY (GHS MODELS) MT/MTEFI**, Page 4.

NOTE: Refer to **ELECTRICAL CONNECTORS**, Page 64 for identification of all Electrical Wiring Service Parts.

LIGHT KIT / COLD START KIT / SPEED UP KIT

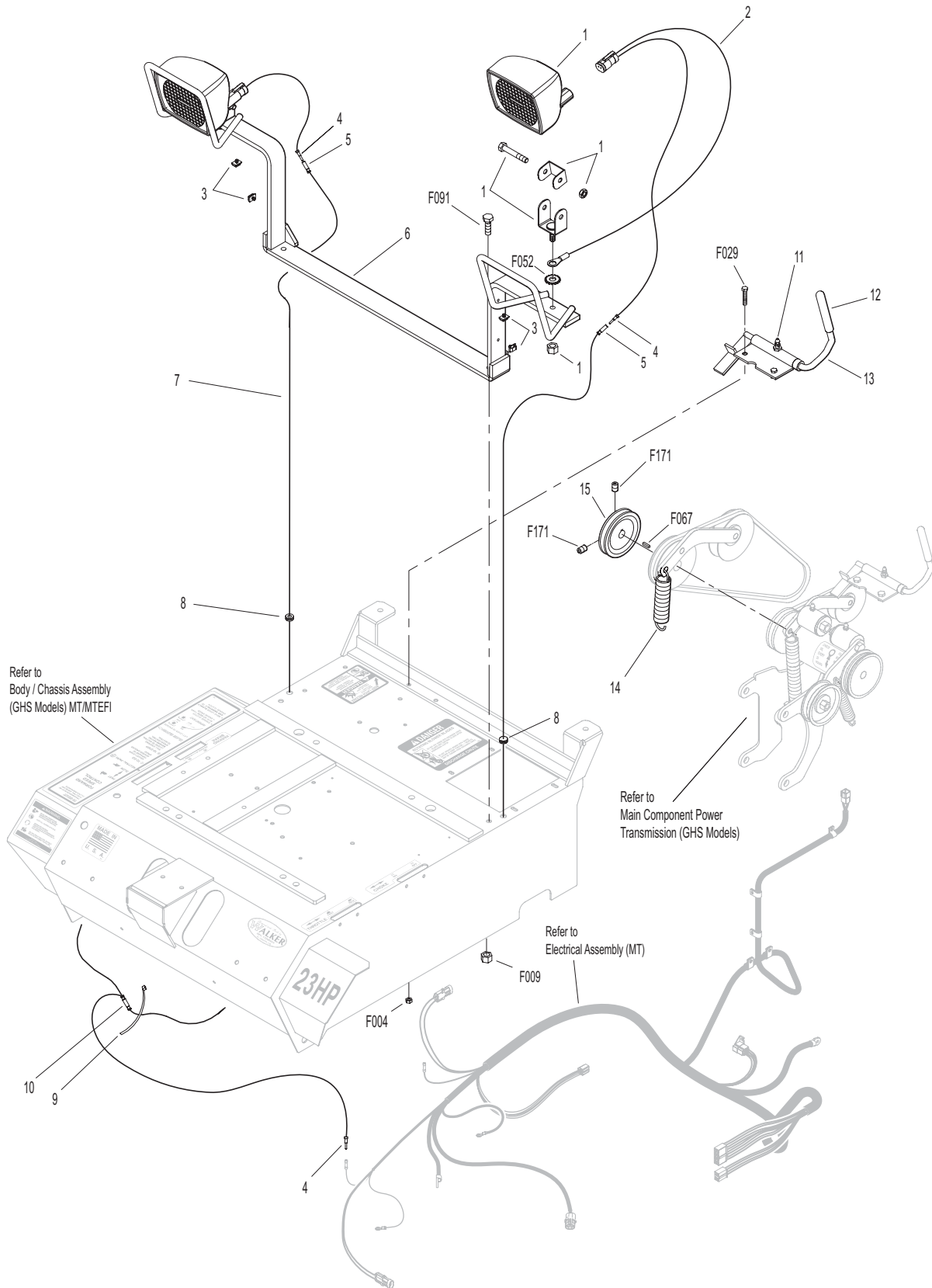

POWER DUMP KIT (9.5 BUSHEL GHS MODELS ONLY)

ITEM NO.	PART NO.	DESCRIPTION	NO. REQ'D
----------	----------	-------------	-----------

Kit 8620-1 Power Dump Option / Kit (9.5 Models Only)

Includes Items # 1-32, fasteners listed and instructions. May be ordered as a factory-installed option or as a kit for dealer installation. Contact your Walker dealer.

1	5522-20	Hinge Backup Plate/RH/PD	1
2	7620-3	Pivot Bushing (1/2 x 9/16)	2
3	7612-4	Door Actuator Arm, RH	1
4	7612-3	Door Actuator Arm, LH	1
5	5522-10	Hinge Backup Plate/LH/PD	1
6	7610-5	Extension Spring (1/4 x 2-7/8)	1
7	7523-2	Clevis Pin (1/4 x 5/8)	2
8	7623-2	Power Dump Cable	2
9	5975-7	Cable Tie (50# x 11")	1
10	7721	Linear Actuator/9.5	1
11	5552	Ball Joint (1/4-28)	2
12	8620-5	Guard, 9.5 P.D. Motor	1
13	7628-1	Channel Angle, RH	1
14	7620-9	Roller Wheel	2
15	7629	Channel Angle, LH	1
16	5830	Grease Fitting	3
17	7636-1	Actuator Mount, 9.5	1
18	7624-1	Roller Bearing Bolt	1
19	7627	Front Actuator Mount	1
20	7624	Sealed Needle Bearing	1
21	7630-3	Ram Pivot and Spacer	1
22	7625	Fork	1
23	5975-1	Cable Tie (18# x 3-3/4")	1
24	5975-3	Cable Tie (50# x 7")	5
25	7622	Wire Harness	1
26	6623	Toggle Switch	1
27	6623-1	Switch Boot	1
28	7633	Decal, Power Dump	1
29	8105-3	Rear Body Panel, LH (MT/EFI)	1
	8105-35	Rear Body Panel, LH (MTL)	1
30	8105-4	Rear Body Panel, RH (MT/MTEFI)	1
	8105-6	Rear Body Panel, RH (MTL/MTLEFI)	1
31	7620-6	Cable Guide	2
32	7613-1	Door Actuator, 7.0/9.5	2

ITEM NO.	PART NO.	DESCRIPTION	NO. REQ'D
----------	----------	-------------	-----------

Fasteners

F002	10-24 Keps Nut	4
F003	1/4-28 Hex Nut	4
F004	1/4-20 Keps Nut	6
F009	5/16-18 Whiz Locknut	3
F012	3/8-16 Keps Nut	2
F028	10-24 x 3/4 PPHMS	4
F029	1/4-20 x 1/2 Hex Bolt	4
F039	3/8-16 x 1-1/4 Hex Bolt	2
F050	1/4 SAE Washer	4
F068	1/8 x 1 Cotter Pin	2
F069	3/32 x 1/2 Cotter Pin	4
F085	3/16 Rivet Backup Washer	4
F093	5/16-18 x 1 Hex Bolt	2
F134	AN960816L Washer	4
F266	1/2 x 2-3/4 Shoulder Bolt	1
F267	1/2 x 1 x 1/16 Washer	4
F337	1/4-20 x 5/8 Self-Tap Bolt	2

NOTE: Two F009 Fasteners are reused from the Rear Gas Spring Assembly. Refer to **REAR BODY ASSEMBLY (GHS MODELS) MT/MTEFI**, Page 8.

NOTE: Refer to **ELECTRICAL CONNECTORS**, Page 64 for identification of all Electrical Wiring Service Parts.

POWER DUMP KIT (9.5 BUSHEL GHS MODELS ONLY)

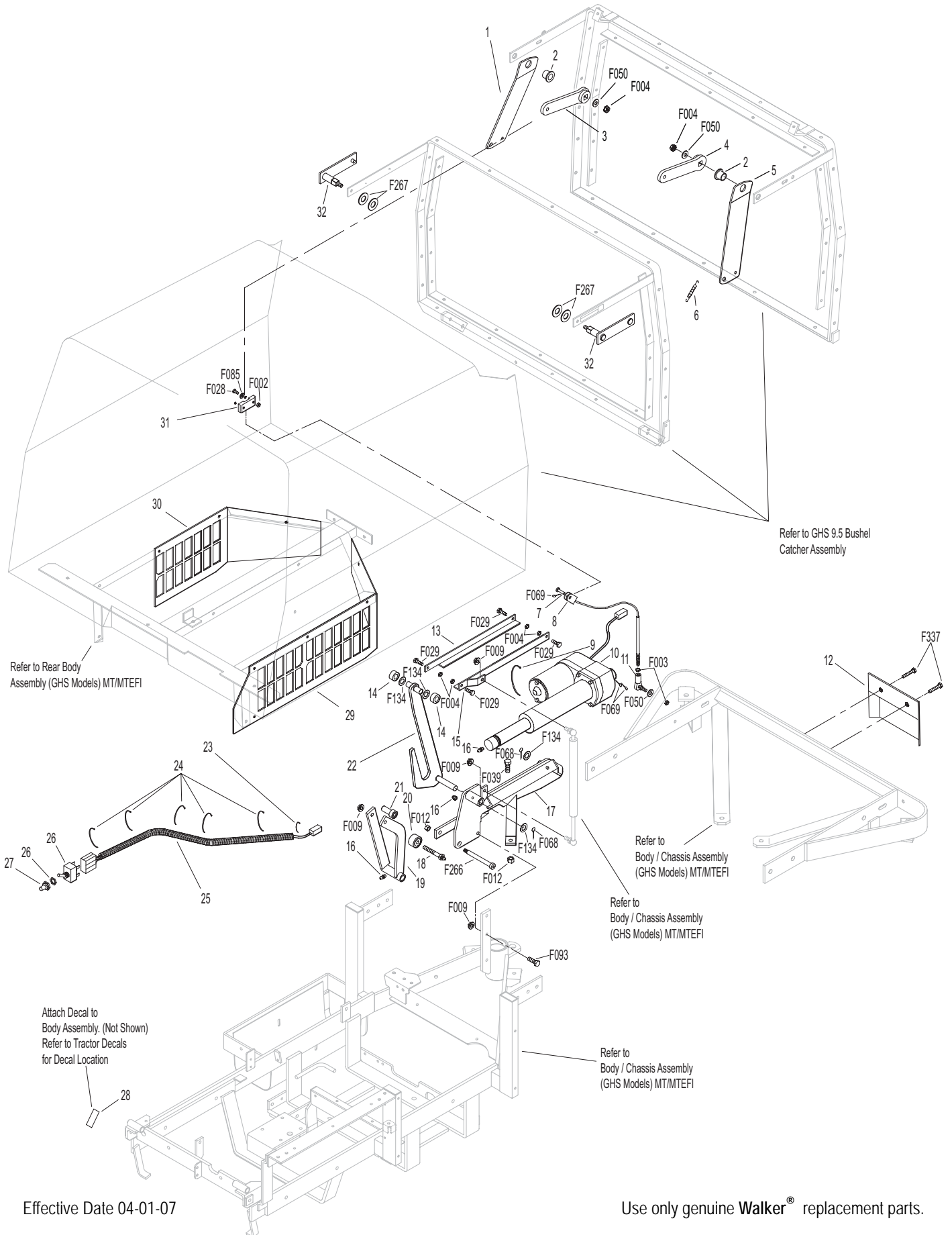

Effective Date 04-01-07

Use only genuine Walker® replacement parts.

POWER DUMP KIT (7.0 BUSHEL GHS MODELS ONLY)

ITEM NO.	PART NO.	DESCRIPTION	NO. REQ'D
Kit 7620-13 Power Dump Option / Kit (7.0 Models Only)			
Includes Items # 1-32, fasteners listed and instructions. May be ordered as a factory-installed option or as a kit for dealer installation. Contact your Walker dealer. Not to be used with optional Dump Bag Kits.			
1	5522-20	Hinge Backup Plate/RH/PD	1
2	7620-3	Pivot Bushing (1/2 x 9/16)	2
3	7612-4	Door Actuator Arm, RH	1
4	7612-3	Door Actuator Arm, LH	1
5	5522-10	Hinge Backup Plate/LH/PD	1
6	7610-5	Extension Spring (1/4 x 2-7/8)	1
7	7523-2	Clevis Pin (1/4 x 5/8)	2
8	7623	Power Dump Cable	2
9	5975-7	Cable Tie (50# x 11")	1
10	7621	Linear Actuator/7.0	1
11	5552	Ball Joint (1/4-28)	2
12	7628-1	Channel Angle, RH	1
13	7620-9	Roller Wheel	2
14	7629	Channel Angle, LH	1
15	5830	Grease Fitting	3
16	7626-0	Actuator Mount	1
17	7624-1	Roller Bearing Bolt	1
18	7627	Front Actuator Mount	1
19	7624	Sealed Needle Bearing	1
20	7630-3	Ram Pivot and Spacer	1
21	7625	Fork	1
22	5975-1	Cable Tie (18# x 3-3/4")	1
23	5975-3	Cable Tie (50# x 7")	5
24	7622	Wire Harness	1
25	6623	Toggle Switch	1
26	6623-1	Switch Boot	1
27	7633	Decal, Power Dump	1
28	8105-3	Rear Body Panel, LH (MT/EFI)	1
	8105-35	Rear Body Panel, LH (MTL)	1
29	8105-4	Rear Body Panel, RH (MT/MTEFI)	1
	8105-6	Rear Body Panel, RH (MTL/MTLEFI)	1
30	7620-12	Cable Rod Guide (7.0)	2
31	7620-6	Cable Guide	2
32	7613-1	Door Actuator, 7.0/9.5	2

ITEM NO.	PART NO.	DESCRIPTION	NO. REQ'D
Fasteners			
	F002	10-24 Keps Nut	6
	F003	1/4-28 Hex Nut	4
	F004	1/4-20 Keps Nut	6
	F009	5/16-18 Whiz Locknut	4
	F012	3/8-16 Keps Nut	2
	F028	10-24 x 3/4 PPHMS	4
	F029	1/4-20 x 1/2 Hex Bolt	4
	F039	3/8-16 x 1-1/4 Hex Bolt	2
	F050	1/4 SAE Washer	4
	F068	1/8 x 1 Cotter Pin	2
	F069	3/32 x 1/2 Cotter Pin	4
	F085	3/16 Rivet Backup Washer	4
	F093	5/16-18 x 1 Hex Bolt	1
	F128	10-24 x 3/8 PTHMS	2
	F134	AN960816L Washer	4
	F266	1/2 x 2-3/4 Shoulder Bolt	1
	F267	1/2 x 1 x 1/16 Washer	4

NOTE: Two F009 Fasteners are reused from the Rear Gas Spring Assembly. Refer to **REAR BODY ASSEMBLY (GHS MODELS) MT/MTEFI**, Page 8.

NOTE: Refer to **ELECTRICAL CONNECTORS**, Page 64 for identification of all Electrical Wiring Service Parts.

POWER DUMP KIT (7.0 BUSHEL GHS MODELS ONLY)

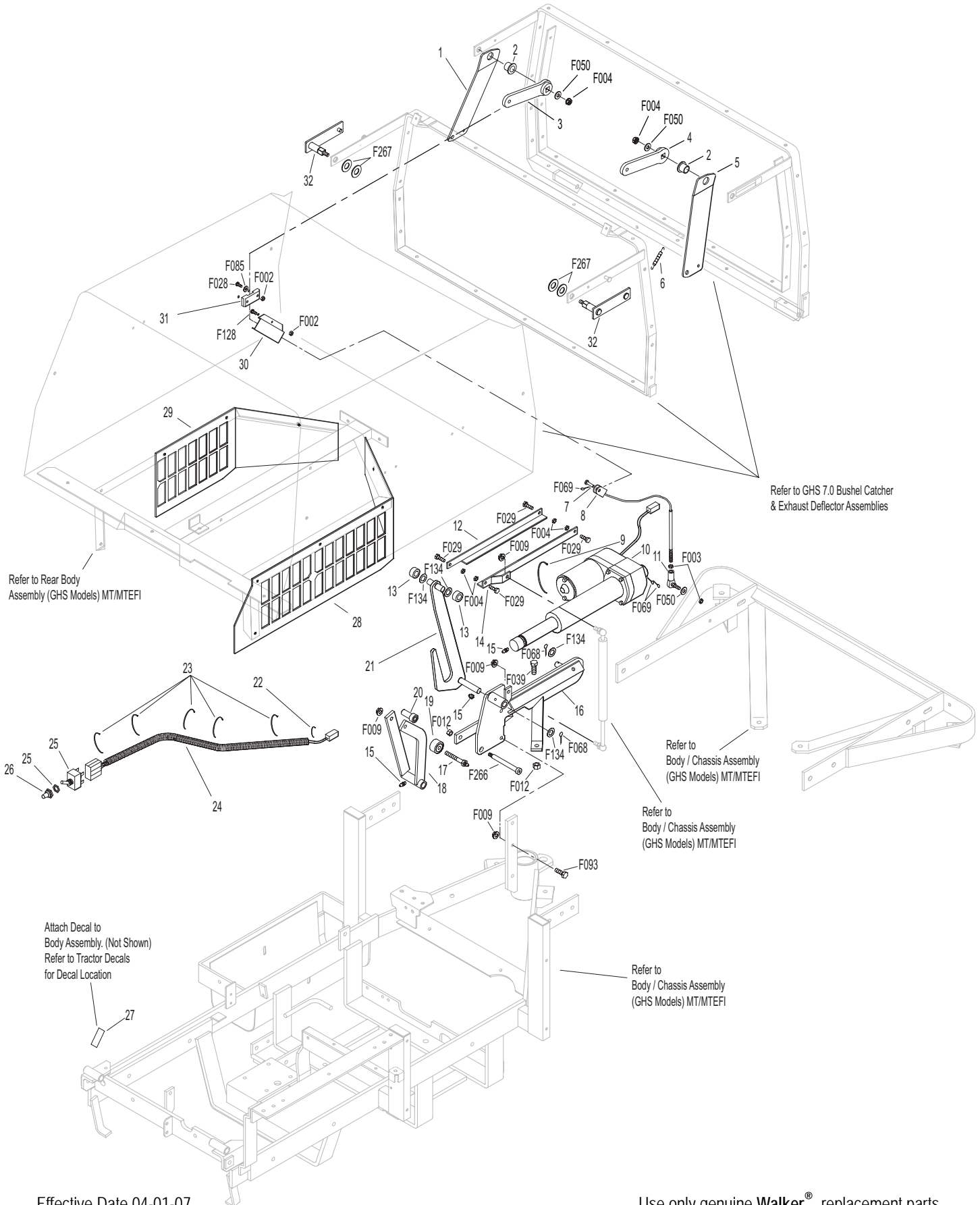

Effective Date 04-01-07

Use only genuine Walker® replacement parts.

HI-DUMP KIT

ITEM NO.	PART NO.	DESCRIPTION	NO. REQ'D	ITEM NO.	PART NO.	DESCRIPTION	NO. REQ'D
Hi-Dump Kit				45	8400-2	Rear Pivot/RH (Includes Items # 20 & 28)	1
1	7613-1	Door Actuator/7.0/9.5	2	46	8402-7	Control Lift Rod	2
2	7612-4	Door Actuator Arm/RH	1	47	5214-9	Ball Joint (7/16-20LH) Hi Strength	2
3	7612-3	Door Actuator Arm/LH	1	48	7847	Rubber Bumper (1.5OD x 1.0)	1
4	7620-6	Cable Guide	2	Fasteners			
5	7523-2	Clevis Pin W/Hole (1/4 x 5/8)	2	F002	10-24 Keps Nut		10
6	7623-2	Power Dump Cable/9.5	2	F003	1/4-28 Hex Nut		2
7	5552	Ball Joint (1/4-28)	2	F004	1/4-20 Keps Nut		8
8	8402-3	Backup Plate	1	F009	5/16-18 Whiz Locknut		15
9	7628-1	Channel Angle/RH	1	F012	3/8-16 Keps Nut		8
10	8404-4	Channel Angle/Hi-Dump/LH	1	F013	3/8-16 Whiz Locknut		4
11	7146	13mm Ball Stud	2	F016	1/2-13 Self-Locking Nut		2
12	7145	Gas Spring Assembly (Includes Items # 11 & 13)	1	F025	10-24 x 3/8 PPHMS		1
13	7147	Spring Clip	2	F028	10-24 x 3/4 PPHMS		4
14	5841	Retainer Washer (3/8 x 1-1/4)	4	F031	1/4-20 x 5/8 Hex Bolt		2
15	8845	Rubber Bumper (30mm OD x 40mm) 5/16-18 Female	3	F034	5/16-18 x 3/4 Hex Bolt		5
16	8404-6	Clevis Pin (1/2 x 1-1/2)	1	F035	5/16-18 x 1-1/4 Hex Bolt		2
17	8402-6	Catcher Pivot Plate, Hi-Dump	2	F037	10-24 x 5/8 PTH Screw		2
18	7620-9	Roller Wheel	2	F038	3/8-16 x 1 Hex Bolt		4
19	8402-2	Catcher Pivot Arm (Includes Item # 20)	1	F039	3/8-16 x 1-1/4 Hex Bolt		4
20	5830	Grease Fitting	5	F040	3/8-16 x 1-1/2 Hex Bolt		3
21	8404-5	Clevis Pin (1/2 x 1-1/4)	1	F048	1/2 SAE Washer		1
22	8402-4	Upper Cylinder Mount Arm	1	F049	5/16 SAE Washer		2
23	8402-1	Catcher Frame/Hi-Dump (Includes Item # 20)	1	F050	1/4 SAE Washer		2
24	7845	Rubber Bumper (1.375 x .63)	2	F052	5/16 Ext. Star Lock Washer		1
25	8401-4	Upper Pivot Shaft	1	F068	1/8 x 1 Cotter Pin		2
26	8401-5	Pivot Arm (Includes Item # 27)	1	F069	3/32 x 1/2 Cotter Pin		2
27	8401-9	Decal, Safety Lockout Arm	1	F085	3/16 Rivet Backup Washer		4
28	5683	Pivot Bearing	2	F106	3/8-16 x 5/8 Hex Bolt		2
29	8401-1	Torsion Spring (1-1/2)	1	F134	AN960816L Washer		2
30	8401-6	Spring Bushing	1	F208	5/16-18 x 2-1/4 Hex Bolt		5
31	8401-3	Safety Lockout Arm	1	F241	.375 x .875 x .10 Washer		2
32	8401-2	Safety Lockout Spring	1	F267	1/2 x 1 x 1/16 Washer		4
33	8400-3	Rear Pivot/LH (Includes Items # 20 & 28)	1	F287	1/4-28 Keps Nut		2
34	5214-8	Ball Joint (7/16-20) Hi Strength	2	F385	1/4 x 1-1/4 Roll Pin		1
35	8400-8	Decal, Hi-Dump	1	F395	1/4-20 x 2-1/4 FHA Screw, SS		4
36	8404-7	Adapter Bracket / MTL	1*	F396	10-24 x 1-1/4 PPH Bolt		2
37	8430-1	Body Chute, Hi-Dump, 10.5"	1	F398	1/4-20 x 2 Hex Bolt		2*
38	8400-10	Auxiliary Power Terminal Plate (Includes Item # 39)	1	F399	1/2-13 x 3-1/4 Hex Bolt		2
39	8400-7	Decal, Electrical Jumper Warning	1	F405	3/8-16 x 1-1/2 FHA Screw, SS		1
40	8400-15	Switch Mount	1	F408	7/16-20 Jam Nut		2
41	8400-9	Decal, Hi-Dump Operation	1	F409	7/16-20 Hex Nut/Left Hand		2
42	8400-14	Switch Cover (Includes Item # 41)	1	F420	5/16-18 x 1-1/4 Carriage Bolt		2
43	8403-13	Pump Guard	1	* Model MTL Only			
44	8400-1	Bumper/Hi-Dump Mount (Includes Item # 35)	1				

Use only genuine Walker® replacement parts.

Effective Date 04-01-07

HI-DUMP KIT

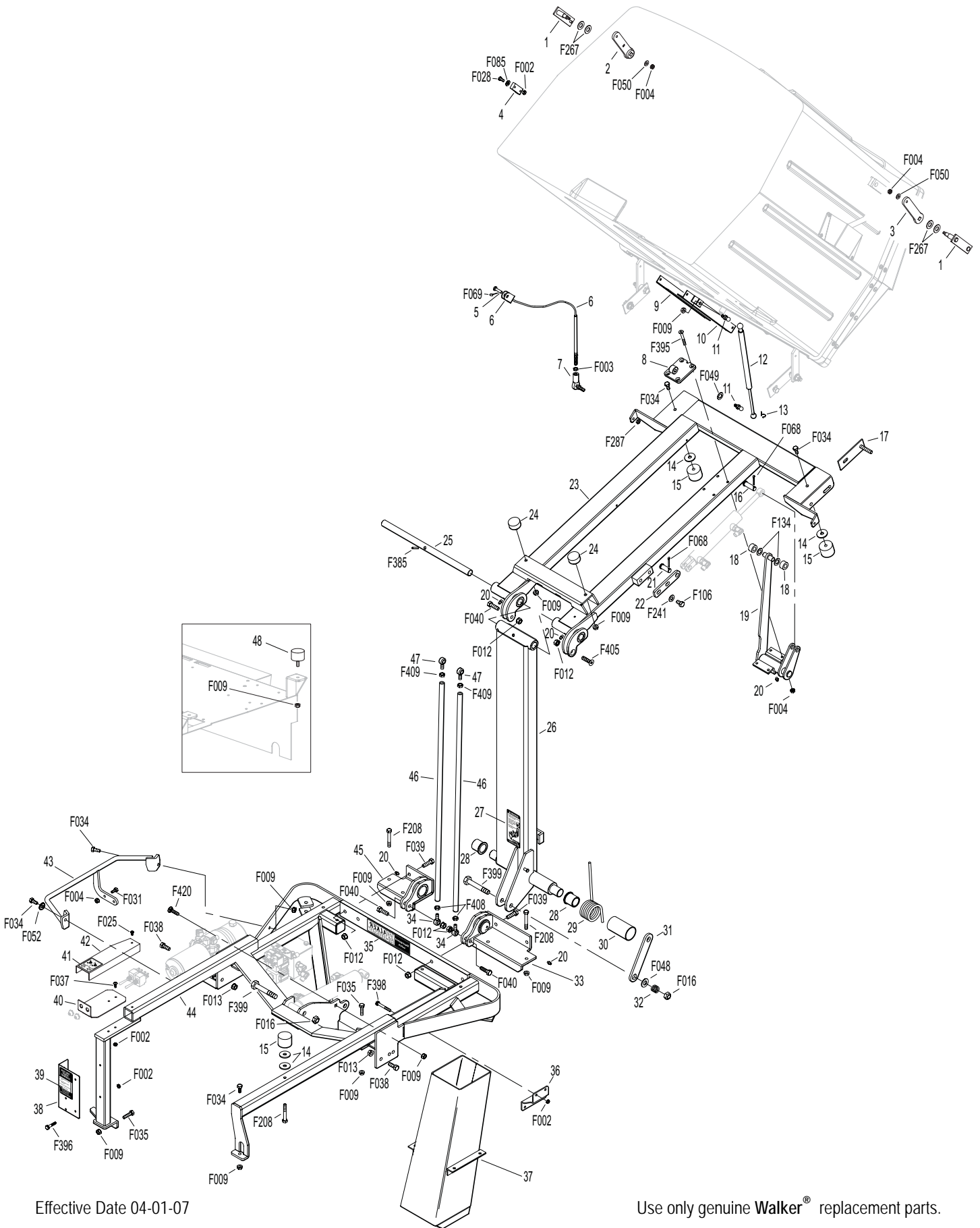

Effective Date 04-01-07

Use only genuine Walker® replacement parts.

HI-DUMP KIT - HYDRAULIC

ITEM NO.	PART NO.	DESCRIPTION	NO. REQ'D	ITEM NO.	PART NO.	DESCRIPTION	NO. REQ'D
Hi-Dump Kit				Component Replacement Part			
1	5833	Cable Clamp (1/4)	3	30	8403-11	Counterbalance Valve	1
2	8440-1	Catcher Adapter Harness	1	31	8403-8	Directional Valve	2
3	8404	Dump Cylinder	1	32	8403-9	Coil W/Connectors	2
4	8403-7	90° Fitting	12	33	8403-14	1/4 HP-S Pipe Plug	1
5	5975-3	Cable Tie (50# x 7")	5	34	8403-1	Reservoir/Power Unit	1
6	8403-6	Hydraulic Hose, Catcher Box Dump (73.5)	1	Fasteners			
7	8403-5	Hydraulic Hose, Catcher Box Dump (67.5)	1				
8	5835	Cable Clamp (3/4)	6	F002		10-24 Keps Nut	9
9	8403-3	Hydraulic Hose, Lift/Rear (11.5)	1	F004		1/4-20 Keps Nut	2
10	8404-1	Lift Cylinder	1	F025		10-24 x 3/8 PPHMS	13
11	8403-2	Hydraulic Hose, Lift/Front (16)	1	F027		10-24 x 5/8 PPHMS	5
12	5975-7	Cable Tie (50# x 11")	2	F106		3/8-16 x 5/8 Hex Bolt	2
13	8404-2	Hydraulic Valve Box	1	F232		10-32 Keps Nut	2
14	8403-4	Hydraulic Hose, Valve to Pump (17-1/2)	2	F431		1/4-20 x 3-1/2 Hex Bolt	2
15	5975-1	Cable Tie (18# x 3-3/4")	9				
16	8403	Hydraulic Power Unit	1				
17	8440-2	Switch Harness	1				
18	5832	Cable Clamp (1/2)	1				
19	8401-7	Junction Block (10-32)	2				
20	7941	Circuit Breaker 40 Amp (Auto Reset/Sealed)	1				
21	8404-9	Plastic Cover/Black	1				
22	8404-8	Plastic Cover/Red	1				
23	6623-1	Switch Boot	2				
24	6623	Toggle Switch	2				
25	8440-3	Jumper Wire	1				
26	8440-4	Extension Wire	1				
27	8440	Wire Harness/Hi-Dump	1				
28	6941	Relay Swtch 30/40AMP (NC)	2				
29	7833	Cable Clamp (7/8 x 1/4)	1				

HI-DUMP KIT - HYDRAULIC

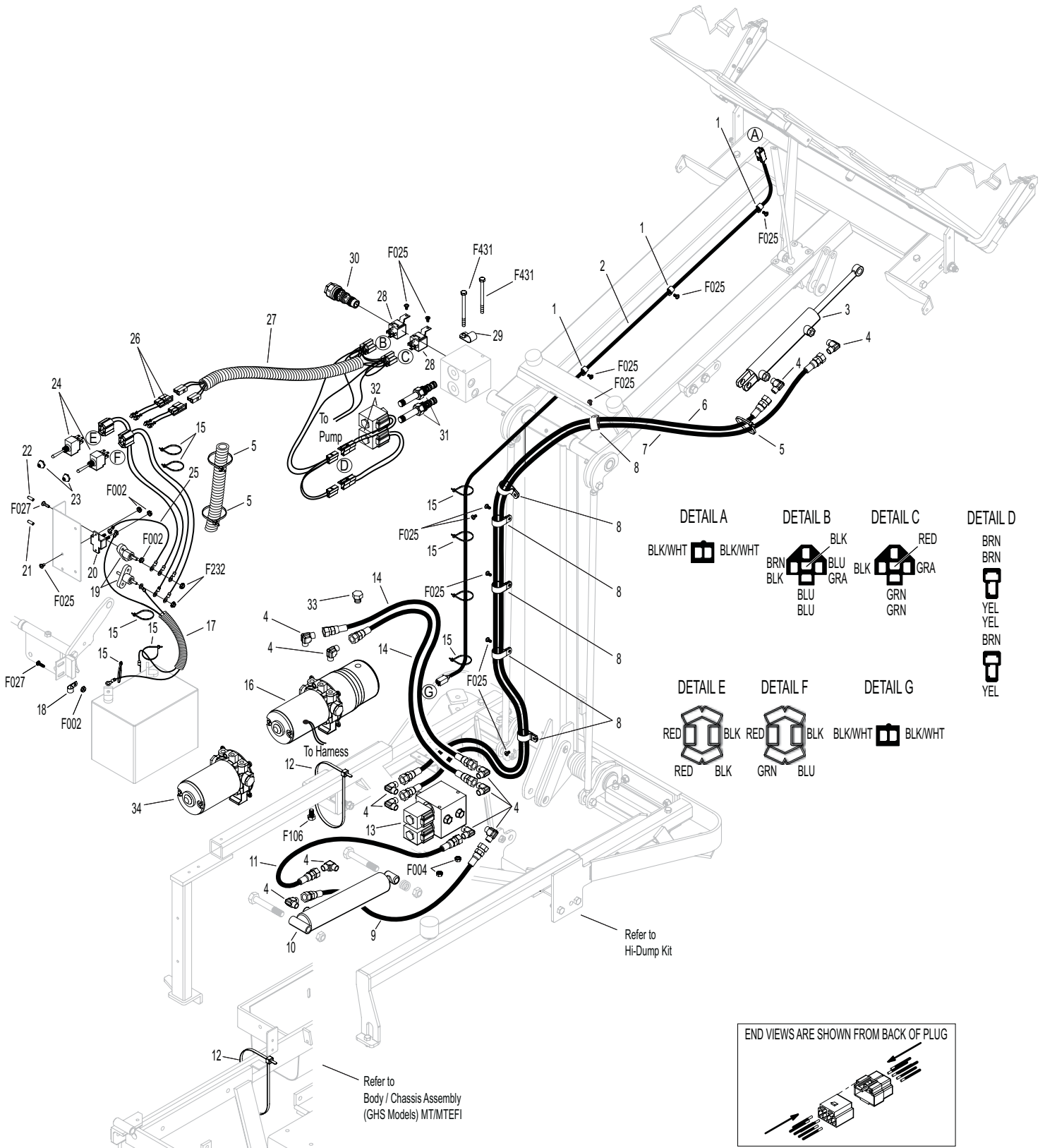

NO CATCH DEFLECTOR KIT / TAIL WEIGHT KIT / SPREAD TAIL WHEEL AXLE KIT

ITEM NO.	PART NO.	DESCRIPTION	NO. REQ'D
----------	----------	-------------	-----------

Kit 8500 (9.5 Bushel) No Catch Deflector Option / Kit
Includes Items # 1-5, fasteners and instructions.

Kit 7500 (7.0 Bushel) No Catch Deflector Option / Kit
Includes Items # 1-5, fasteners and instructions.

No-Catch Deflector kits may be ordered as a dealer-installed option. Contact your Walker dealer.

1	8500	No-Catch Deflector Kit (9.5)	1
	7500	No-Catch Deflector Kit (7.0)	1
2	8500-5	Side Bracket	2
3	8787-2	Knob (1/4-20) Threaded Insert	1
4	8500-6	Spacer Lug	1
5	8500-8	Decal, No Catch Deflector	1

Kit 7647 Tail Weight Option / Kit
Includes Items # 6, F012, F039 and instructions. May be ordered as a dealer-installed option. Contact your Walker dealer.

6	7647-9	Tail Weight Strap	2
7	7647-5	Tail Weight Plate, 10-lb	*

Kit 7647-1 Tail Weight Kit / MTL
Includes Items # 8, F012, F039 and instructions. May be ordered as a dealer-installed option. Contact your Walker dealer.

7	7647-5	Tail Weight Plate, 10-lb	*
8	7647-8	Tail Weight Strap (MTL)	2

Kit 7420-3 Spread Axle Kit/Less Wheels
Includes Items # 9-22, fasteners listed & instructions. May be ordered as a dealer-installed option. Contact your Walker dealer.

9	7420-6	Washer (2-1/2)	1
10	7420-11	Mount, Spread Axle	1
11	8769-8	Dust Cap, Deck Caster	2
12	8769-6	Bearing Cone (1" ID)	4
13	8769-5	Bearing Cup	4

ITEM NO.	PART NO.	DESCRIPTION	NO. REQ'D
----------	----------	-------------	-----------

14	7420-4	Fork Mount Tube (Includes Item # 13)	1
15	8769-7	Seal	2
16	7420-2	Tail Fork, Spread Axle	2
17	8039	Nut, Tail Wheel Axle	2
18	8038-1	Spacer, Tail Wheel Axle	2
19	7038	Tail Wheel Axle (3/4 x 5-9/16)	2
20	5683	Pivot Bearing	2
21	5830	Grease Fitting	3
22	7420-9	Pivot Shaft	1

Fasteners

F002	10-24 Keps Nut	4
F012	3/8-16 Keps Nut	10
F016	1/2-13 Self-Locking Nut	2
F030	1/4-20 x 1/2 PPH Bolt	1
F039	3/8-16 x 1-1/4 Hex Bolt	6
F128	10-24 x 3/8 PTHMS	4
F140	7/16-14 x 1 Hex Bolt	4
F175	1/2 Split Lock Washer	2**
F205	5/16-18 x 1/4 Set Screw	2
F218	7/16 Split Lock Washer	4
F285	1/2-13 x 1-1/2 Hex Bolt	2**
F333	1/4-20 x 3/4 PTHMS	1
F344	3/4-16 Slotted Hex Nut	2
F347	3/4 SAE Washer	2
F348	1/8 x 1-1/2 Cotter Pin	2
F377	1/2-13 x 5 Hex Bolt	1
F423	1/2-13 x 6-1/2 Hex Bolt	1

* Optional

** Use with optional 10-lb plate.

NOTE: If equipped, existing dual tail wheels and tires can be reused with kit 7420-3. Order Kit # 7420-20 for two wheels and tires if tractor is equipped with a single wide tail wheel.

NO CATCH DEFLECTOR KIT / TAIL WEIGHT KIT / SPREAD TAIL WHEEL AXLE KIT

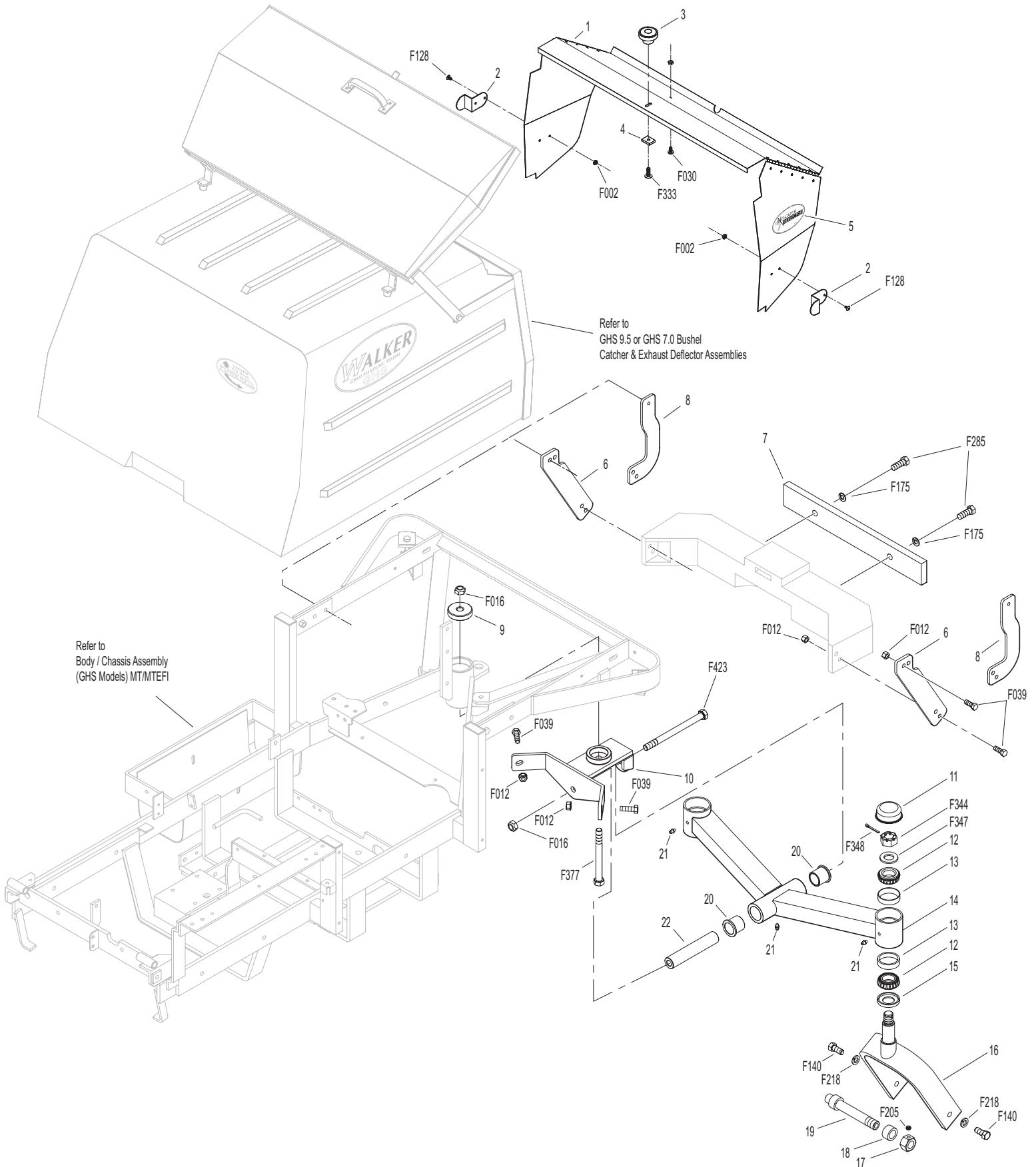

Effective Date 04-01-07

Use only genuine Walker® replacement parts.

TAIL WHEEL LOCK KIT / BLOWER LOCKOUT KIT / CASE-HARDENED BLOWER

ITEM NO.	PART NO.	DESCRIPTION	NO. REQ'D	ITEM NO.	PART NO.	DESCRIPTION	NO. REQ'D
Kit 8540 Tail Wheel Lock Option / Kit Includes Items # 1-28, fasteners listed & instructions. May be ordered as a dealer-installed option. Contact your Walker dealer.				Kit 7541 Blower Lockout Kit Includes Items # 29-35, fasteners and instructions. May be ordered as a kit for dealer installation. Contact your Walker dealer.			
1	5995-2	Switch Boot	1	29	7854	Plastic Tip, Red	*
2	8547	Switch Mount	1	30	6541-2	Blower Lockout Rod (Includes Item # 29)	1
3	8555	Decal, Tail Lock Switch	1	31	6541-1	Blower Lockout Latch	1
4	5995	Toggle Switch (Off-On)	1	32	5280	Clevis (1/4)	1
5	7942-4	Single Connector, Male	2*	33	5281-5	Clevis Pin (1/4 x 0.80)	1
6	5940-4	16-14 GA Spg. Loaded Term., Female	5*	34	6541-3	Blower Lockout Pivot Arm	1
7	5977-2	Grommet, Cut (1/8 x 3/8)	1	35	6541-4	Blower Lockout Belt Guide	1
8	5975-3	Cable Tie (50# x 7")	4	Kit Case Hardened Scroll Option			
9	8550	Wire Harness	1	36	7542-6	Blower Scroll (10.5) (Includes Item #37)	*
10	5975-1	Cable Tie (18# x 3-3/4")	3	37	6542-50	Decal, "H" (5/8)	1
11	8553	Splice Tap (18-14 GA)	1	Fasteners			
12	8543	Solenoid Mount	1	F002	10-24 Keps Nut		4
13	5830-3	Grease Fitting (45 Degree)	1	F003	1/4-28 Hex Nut		2
14	8551	Ground Wire	1	F004	1/4-20 Keps Nut		5
15	8546	Solenoid, Control Module	1	F012	3/8-16 Keps Nut		2
16	5996	1/4 x 16-14 GA QDF Terminal	5*	F026	10-24 x 1/2 PPHMS		2
17	8552	Connector Plug & Wire Assy	1	F029	1/4-20 x 1/2 Hex Bolt		2
18	8544	Clevis, Wheel Lockout (9/16)	1	F032	1/4-20 x 3/4 Hex Bolt		1
19	5551-1	Pivot Bearing	2*	F038	3/8-16 x 1 Hex Bolt		2
	8545-1	Pivot Bearing Assembly (Includes Items # 19, 20, F179 & F350)		F050	1/4 SAE Washer		2
20	8544-1	Bearing Spacer (1/4 ID x 9/16)	1*	F091	5/16-18 x 5/8 Hex Bolt		1
21	8542	Tail Wheel Fork, Locking	1	F134	AN960816L Washer		1
22	8944	3-Way Locking Connector, Male	1*	F179	1/4-20 x 1 Hex Bolt		2
23	8944-1	3-Way Locking Connector, Female	1*	F186	5/64 x 1/2 Cotter Pin		1
24	5940-5	16-14 GA Spg. Loaded Term., Male	1*	F190	#10 Internal Star Lock Washer		1
25	5996-13	16-14 GA Ring Term., #10	1*	F198	.250 x .625 x .040 Washer, SS		1
26	7929	Actuating Solenoid	1	F298	3/8-24 Jam Nut		1
27	8549	Sleeve, Delrin	1	F299	10-24 x 1 PPHMS		2
28	8541	Plunger Rod	1	F300	1.015 x 1.500 x .031 Washer		1
	8554	Solenoid & Mount Assembly (Includes Items # 12-15, 17-20, 26-28, F002, F003, F004, F029, F050, F179, F190, F198, F298, F299 & F350)	*	F325	1/4-20 x 3 Hex Bolt		1
				F350	1/4-20 LP Nylock		1

* Service Part Only

NOTE: Refer to **ELECTRICAL CONNECTORS**, Page 64 for identification of all Electrical Wiring Service Parts.

WIDE TAIL WHEEL / ALL-TERRAIN TIRE KIT & TIRE CHAIN SET

ITEM NO.	PART NO.	DESCRIPTION	NO. REQ'D
----------	----------	-------------	-----------

Kit 8049 Wide Tail Wheel Option / Kit
Includes Items # 1, 3 and instructions. May be ordered as a dealer-installed option. Contact your Walker dealer.

1	8037-1	Seal, Outer (1-3/4 x 1-1/8)	2
2	8048	Wide Tail Wheel Axle	1
3	8045	Wide Tail Wheel & Tire (13 x 8.00-6)	1
	8045-1	Wide Tire (13 x 8.00-6)	*
	8047	Wheel & Hub (6 x 7)	*

AT8072 All-Terrain Tire Option

Includes Item # 4 and instructions. May be ordered as a dealer-installed option. Contact your Walker dealer.

4	8070-6	AT Wheel & Tire RH/LH (18 x 11-10)	2
	8070-7	AT Tire RH/LH (18 x 11-10)	*
	8070-8	AT/LP Wheel (10 x 8.5)	*
	8075-2	AT/LP Tire Tube (18 x 11-10)	*
5	8070-31	Wheel Spacer Plate (1/2)	2

ITEM NO.	PART NO.	DESCRIPTION	NO. REQ'D
----------	----------	-------------	-----------

Kit LP8075 Low Profile Tire Option / Kit
Includes Item # 6 and instructions. May be ordered as a factory-installed option, or as a kit for dealer installation. Contact your Walker dealer.

6	8075	LP Wheel & Tire (18 x 10.5-10)	2
	8075-1	LP Tire (18 x 10.5-10)	*
	8070-8	AT/LP Wheel (10 x 8.5)	*
	8075-2	AT/LP Tire Tube (18 x 11-10)	*

Optional Tire Chain Set

7	5675-3	Tire Chain Set (18 x 9.50-8)	1
---	--------	------------------------------	---

* Service Part Only

WIDE TAIL WHEEL / ALL-TERRAIN TIRE KIT & TIRE CHAIN SET

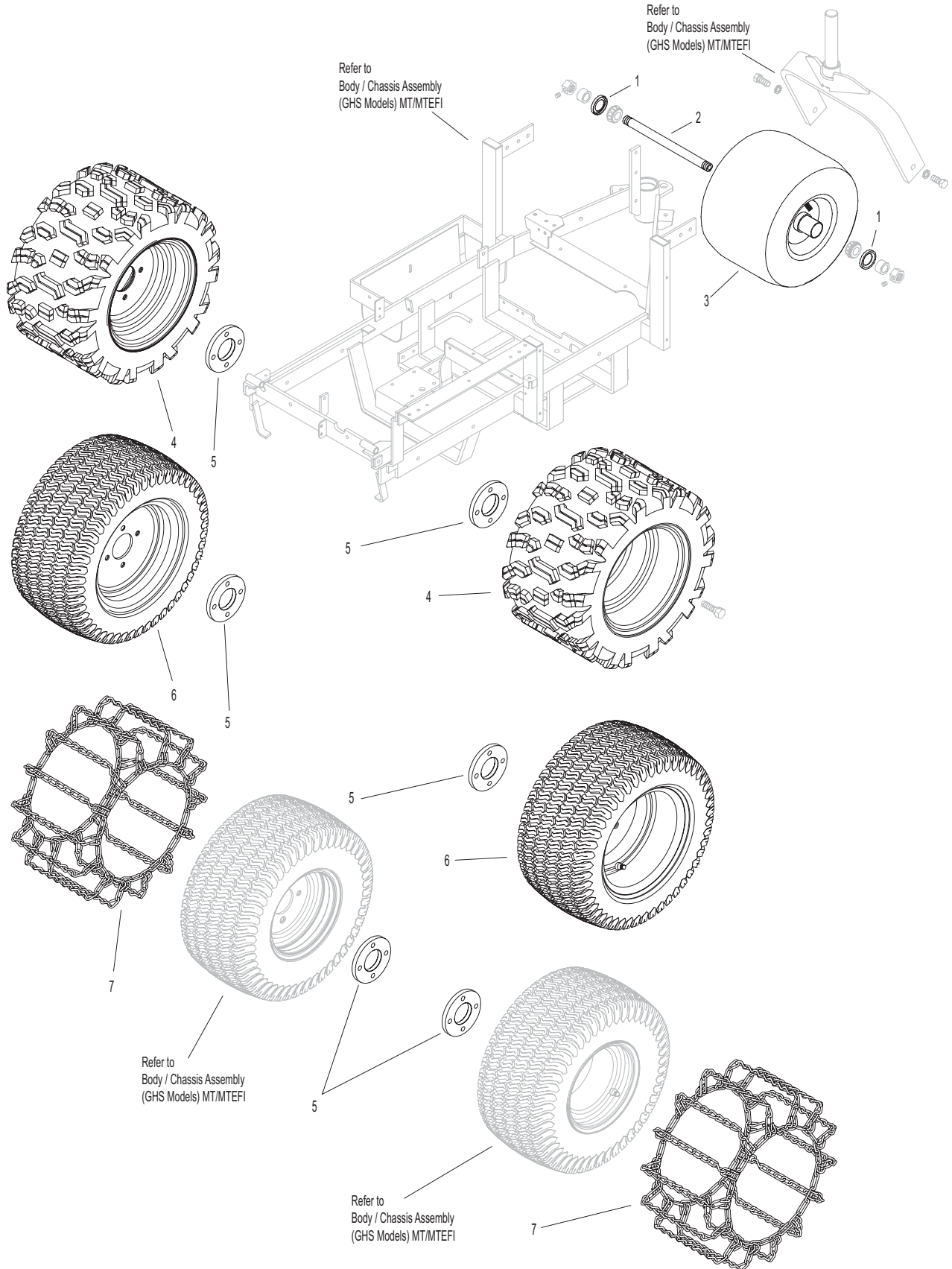

LUBRICATION POINTS

ITEM NO.	LOCATION	LUBRICATION TYPE	NO. PLACES	ITEM NO.	LOCATION	LUBRICATION TYPE	NO. PLACES
Lubrication Points				25	Brake Actuator Rod and Brake Band Pivot Pins (Clevis)	Oil	3
1	Deck Caster Wheel Fork Pivot	Grease	2	26	Brake Actuator Pivot	Grease	1
2	Deck Caster Wheel Bearing	Grease	2	27	Catcher Hinge Point	Oil	2
3	Tee Gearbox, Deck	Oil*	1	28	Rear Wheel Bearings	Grease	2
4	Blade Drive Gearbox	Oil*	2	29	Engine Oil	Oil***	1
5	Universal Joint Shaft Assembly	Grease**	1	30	Choke Control Cable Ends (Models MT and MTL only)	Oil	2
6	Pivot Assembly, Tilt-Up Deck	Grease	4	31	Belt Tightener Pivot, Blower Drive (GHS Model Only)	Grease	1
7	Deck Support Arm Socket	Grease	2	32	Belt Tightener Pivot, Ground Drive	Grease	1
8	Body Hinge Point	Oil	2	33	PTO Gearbox Dipstick	Oil***	1
9	FSC Actuator Rod Pivot Pins	Oil	2	34	Hydrostatic Drive	Oil***	2
10	FSC Lever Pivot	Grease	1	35	Choke Control Pivot (Models MT and MTL only)	Oil	1
11	FSC Lever Fork (Grease Slide Area)	Grease	1	36	Throttle Control Pivot	Oil	1
12	(FSC) Friction Body Pivot	Grease	1				
13	Steering Lever Pivot	Grease	4				
14	Deck Support Arm Pivot	Grease	2				
15	Deck-to-PTO Coupling (Grease Slide Area)	Grease	1				
16	Universal Joint Tube Assembly	Grease**	1				
17	Universal Joint Quick Connect Spline (Grease Slide Area)	Grease	1				
18	Parking Brake Lever	Grease	1				
19	Gear Axle	Oil***	2				
20	Belt Tightener Pivot, Jackshaft Drive	Grease	1				
21	Throttle Control Cable Ends	Oil	2				
22	Clutch Actuator Push Rod	Grease	2				
23	PTO Clutch Lever Pivot	Grease	1				
24	Belt Tightener Pivot, PTO Clutch	Grease	1				

* Gearboxes are permanently lubricated and sealed requiring no scheduled lubrication. Oil level should be checked only when an oil leak is noted.

** Grease every eight (8) hours.

*** Refer to MT **Owner's Manual** for procedure for checking and changing oil in Engine Crankcase, Hydrostatic Transmissions and Gear Axles.

NOTE: See Model MT **Owner's Manual** (P/N 8000-11) for proper lubrication intervals.

NOTE: DGHS42 Tilt-Up Deck is shown for reference. For other Deck Lubrication Points, Refer to Deck and Carrier Frame **Illustrated Parts Manual**.

LUBRICATION POINTS

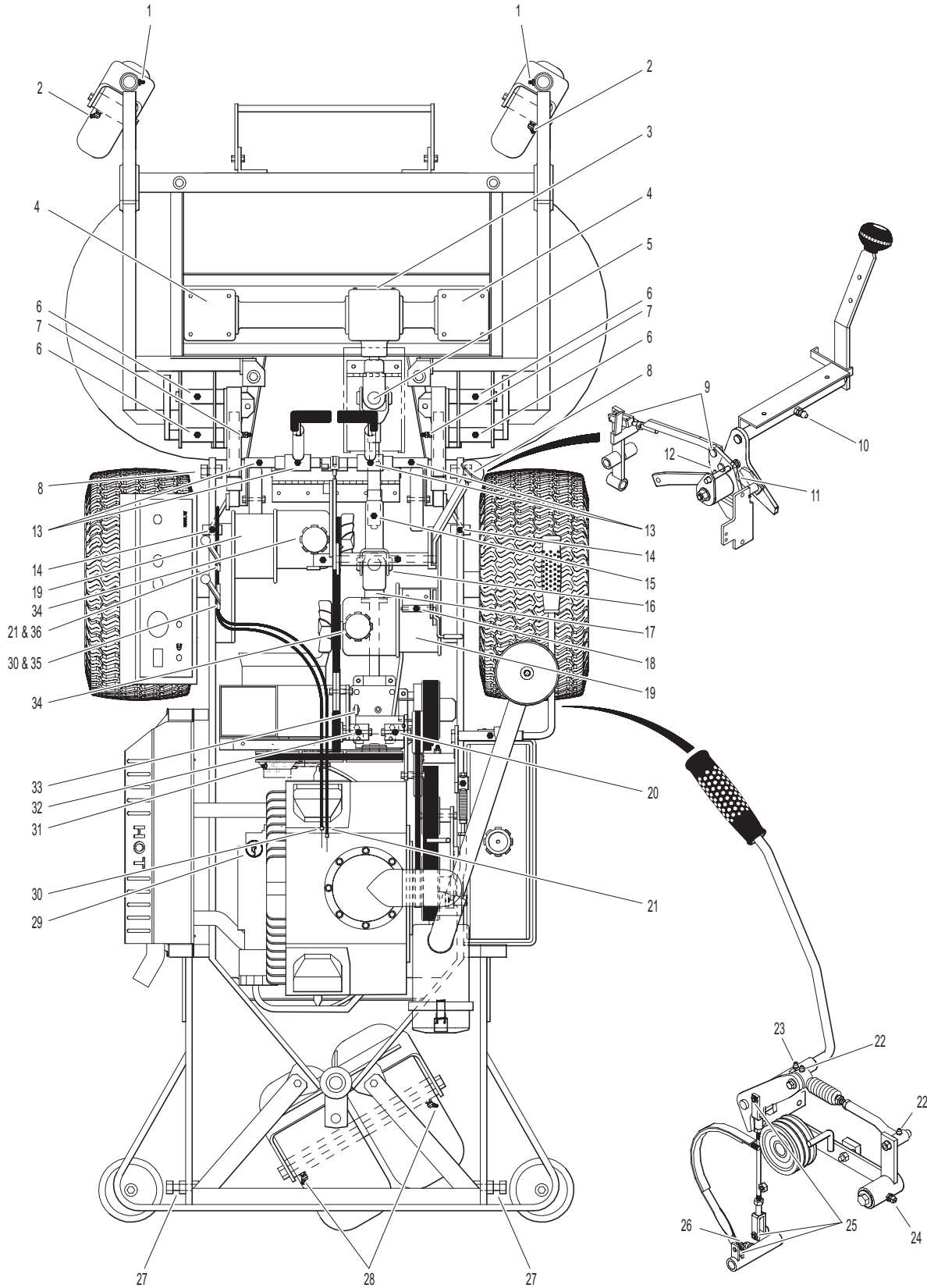

WIRING SCHEMATIC (MT)

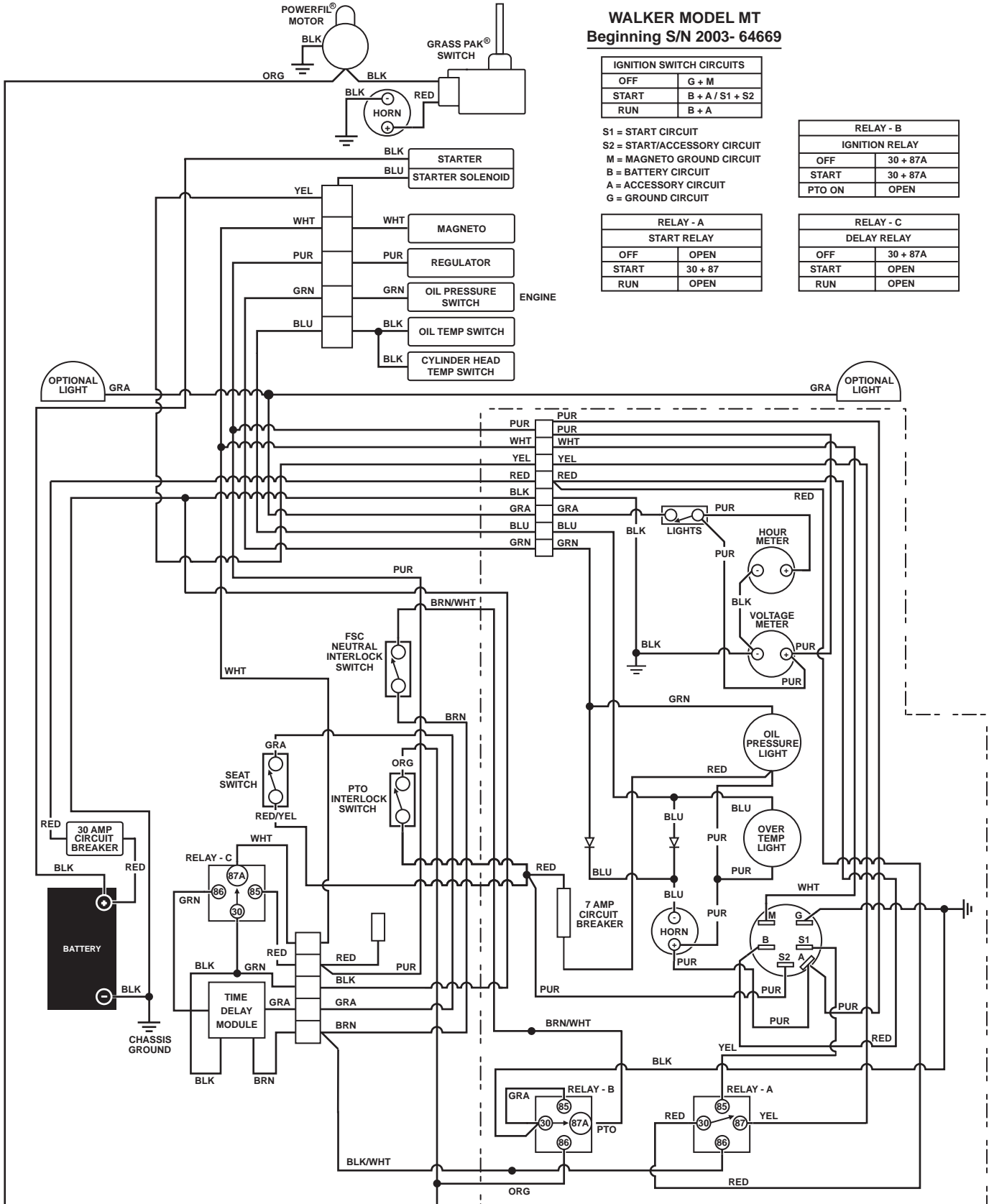

Use only genuine Walker® replacement parts.

Effective Date 04-01-07

WIRING SCHEMATIC (MTL)

WALKER MODEL MTL Beginning S/N 2003-64669

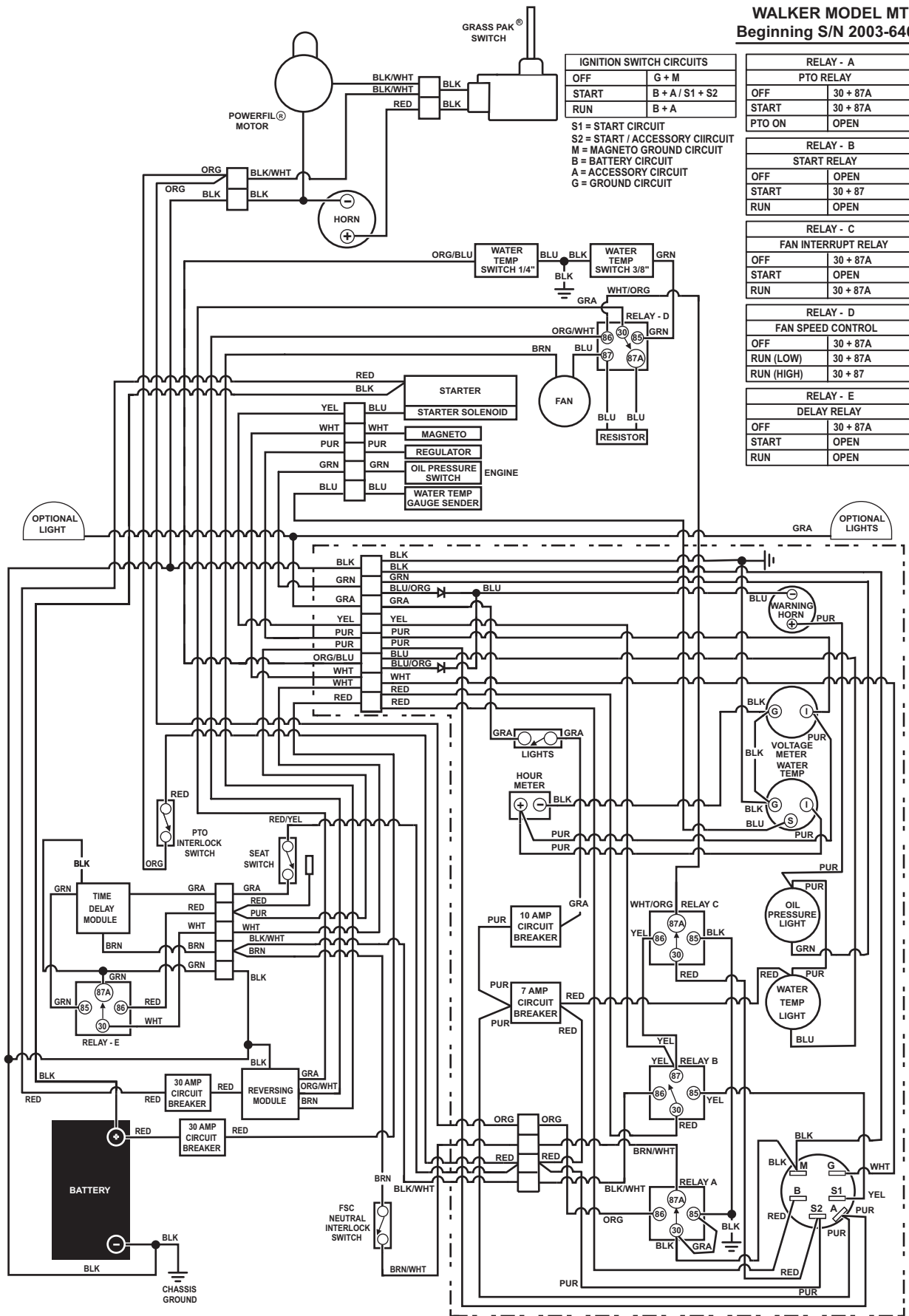

WIRING SCHEMATIC (MTEFI)

WALKER MODEL MT-EFI Beginning S/N 2003-64669

IGNITION SWITCH CIRCUITS	
OFF	G + M
START	B + A / S1 + S2
RUN	B + A

S1 = START CIRCUIT
 S2 = START / ACCESSORY CIRCUIT
 M = MAGNETO GROUND CIRCUIT
 B = BATTERY CIRCUIT
 A = ACCESSORY CIRCUIT
 G = GROUND CIRCUIT
 J1 = #1 FUEL INJECTOR
 J2 = #2 FUEL INJECTOR
 J3 = THROTTLE POSITION SENSOR
 J4 = OIL TEMP SENSOR
 J5 = OXYGEN SENSOR
 J6 = REGULATOR / RECTIFIER
 J8 = ENGINE GROUND
 J10 = #1 IGNITION COIL
 J11 = #2 IGNITION COIL
 J12 = #1 IGNITION COIL
 J13 = #2 IGNITION COIL
 J14 = IGNITION COIL GROUND
 J20 = SPEED PICK-UP SENSOR

RELAY - A IGNITION / FUEL RELAY	
OFF	OPEN
START	OPEN
PTO ON	30 + 87

RELAY - B DELAY RELAY	
OFF	30 + 87A
START	OPEN
RUN	OPEN

RELAY - C START / TIME DELAY RELAY	
OFF	30 + 87A
START	30 + 87A
RUN	OPEN

RELAY - D START / SOLENOID RELAY	
OFF	OPEN
RUN (LOW)	OPEN
RUN (HIGH)	30 + 87

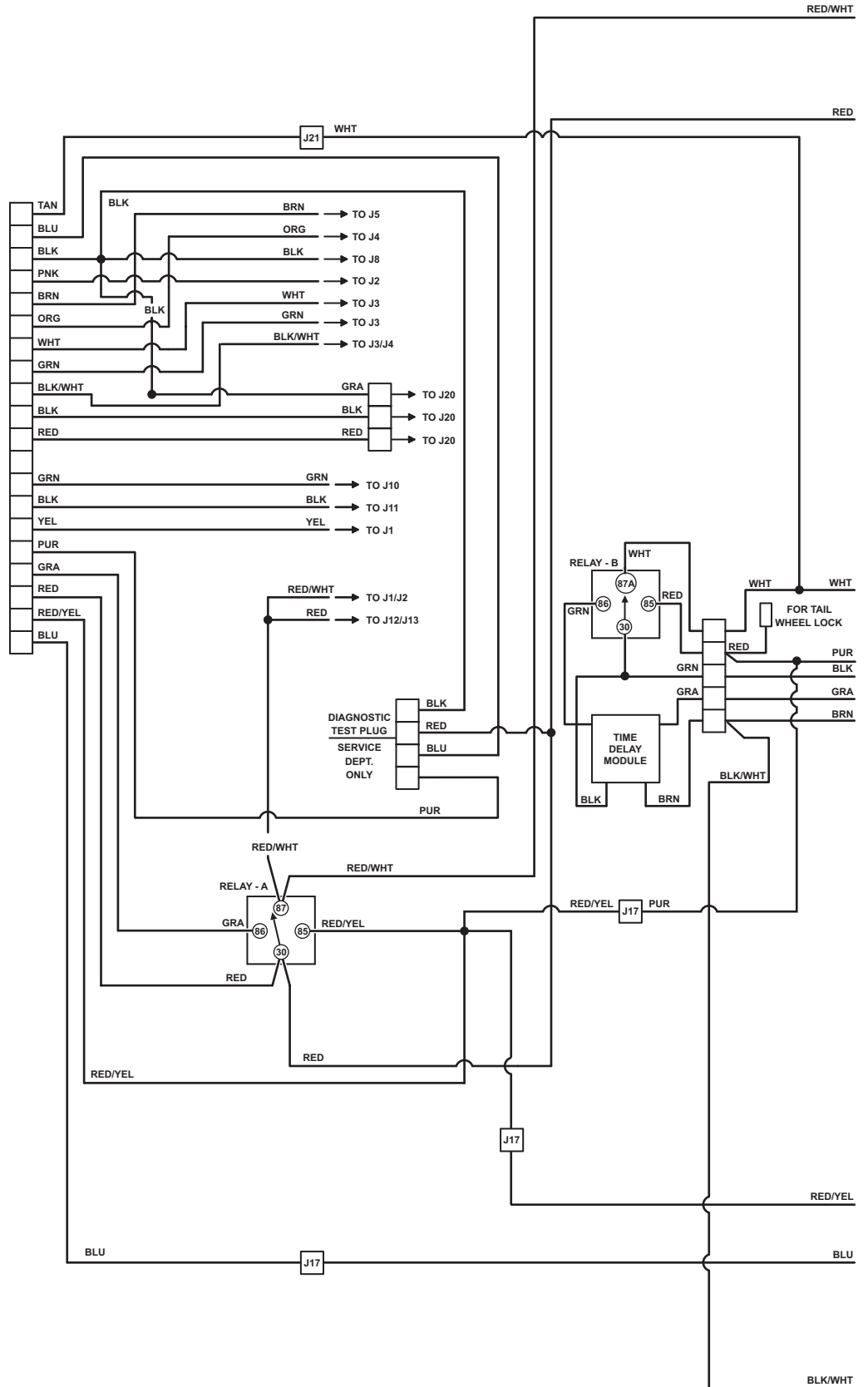

WIRING SCHEMATIC (MTEFI)

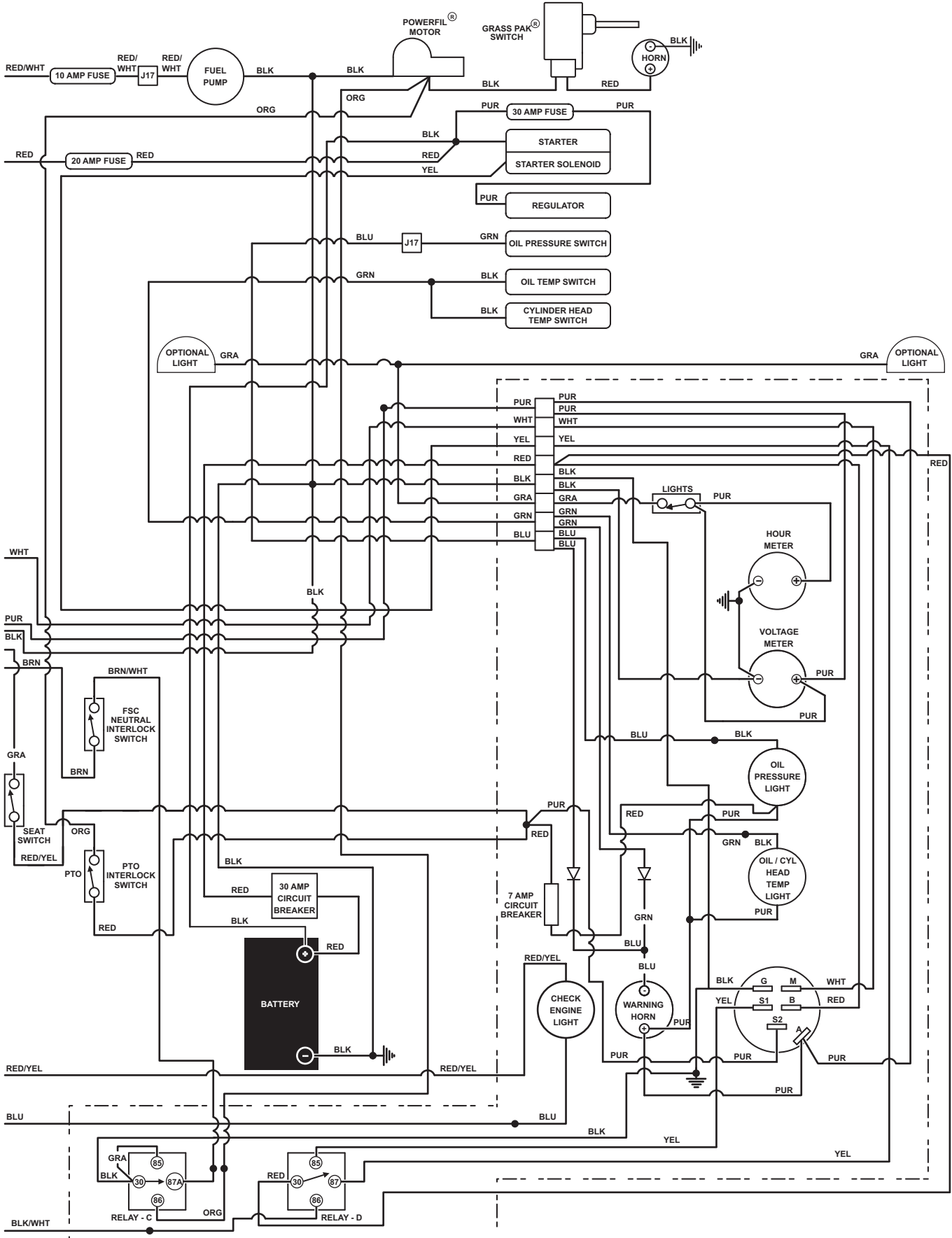

Effective Date 04-01-07

Use only genuine Walker® replacement parts.

WIRING SCHEMATIC (MTLEFI)

WALKER MODEL MTL-EFI Beginning S/N 2005-75988

- S1 = START CIRCUIT
- S2 = START / ACCESSORY CIRCUIT
- M = MAGNETO GROUND CIRCUIT
- B = BATTERY CIRCUIT
- A = ACCESSORY CIRCUIT
- G = GROUND CIRCUIT
- J1 = #1 FUEL INJECTOR
- J2 = #2 FUEL INJECTOR
- J3 = THROTTLE POSITION SENSOR
- J4 = OIL TEMP SENSOR
- J5 = OXYGEN SENSOR
- J6 = REGULATOR / RECTIFIER
- J8 = ENGINE GROUND
- J10 = #1 IGNITION COIL
- J11 = #2 IGNITION COIL
- J12 = #1 IGNITION COIL
- J13 = #2 IGNITION COIL
- J14 = IGNITION COIL GROUND
- J20 = SPEED PICK-UP SENSOR

RELAY - A	
PTO RELAY	
OFF	30 + 87A
START	30 + 87A
PTO ON	OPEN

RELAY - B	
START RELAY	
OFF	OPEN
START	30 + 87
RUN	OPEN

RELAY - C	
FAN INTERRUPT RELAY	
OFF	30 + 87A
START	OPEN
PTO ON	30 + 87A

RELAY - D	
FAN SPEED CONTROL	
OFF	30 + 87A
START	30 + 87A
PTO ON	30 + 87

RELAY - E	
DELAY RELAY	
OFF	30 + 87A
START	OPEN
PTO ON	OPEN

RELAY - F	
IGNITION / FUEL RELAY	
OFF	OPEN
START	OPEN
PTO ON	30 + 87

IGNITION SWITCH CIRCUITS	
OFF	G + M
START	B + A / S1 + S2
RUN	B + A

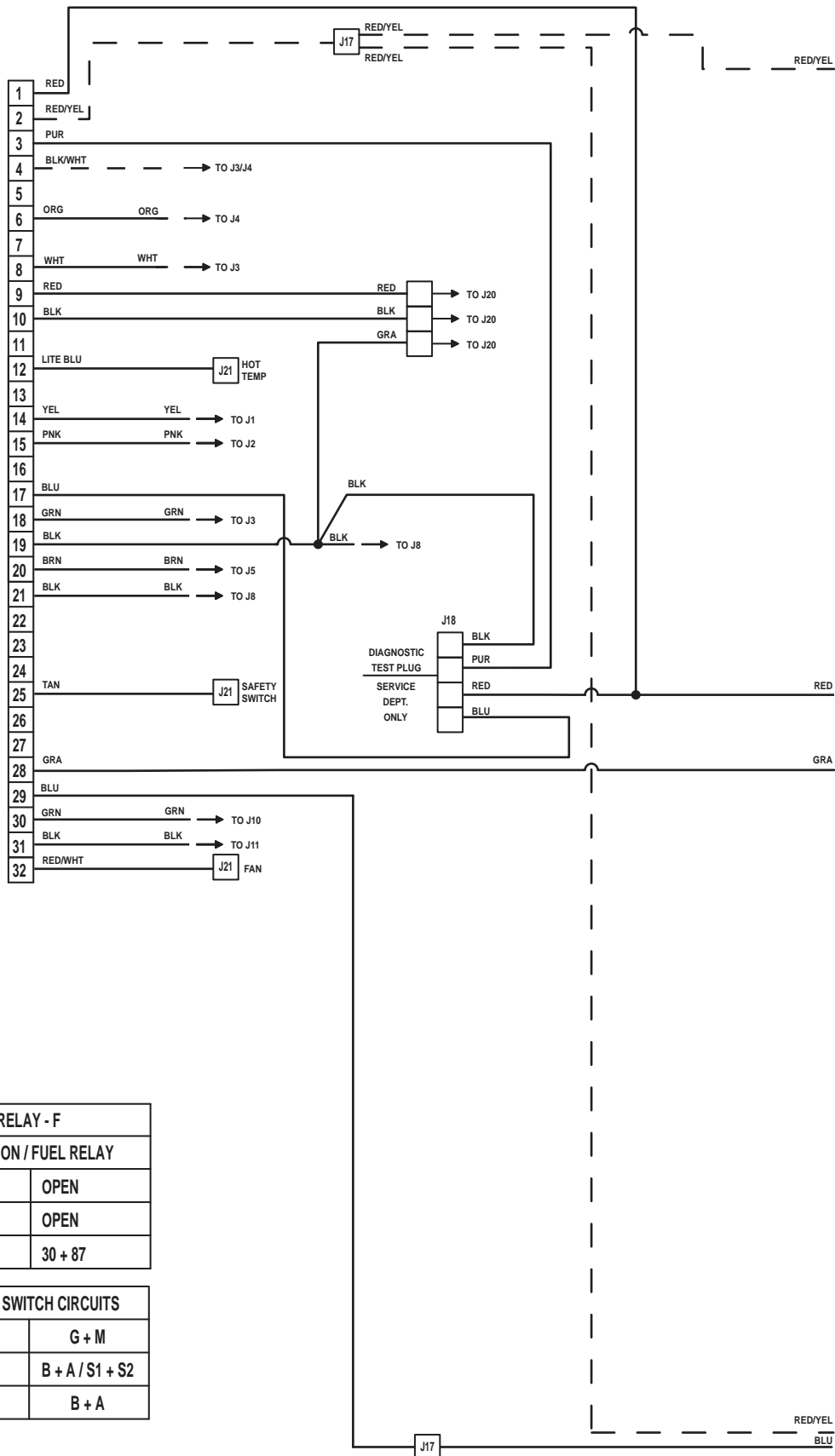

Use only genuine Walker® replacement parts.

Effective Date 04-01-07

WIRING SCHEMATIC (MTLEFI)

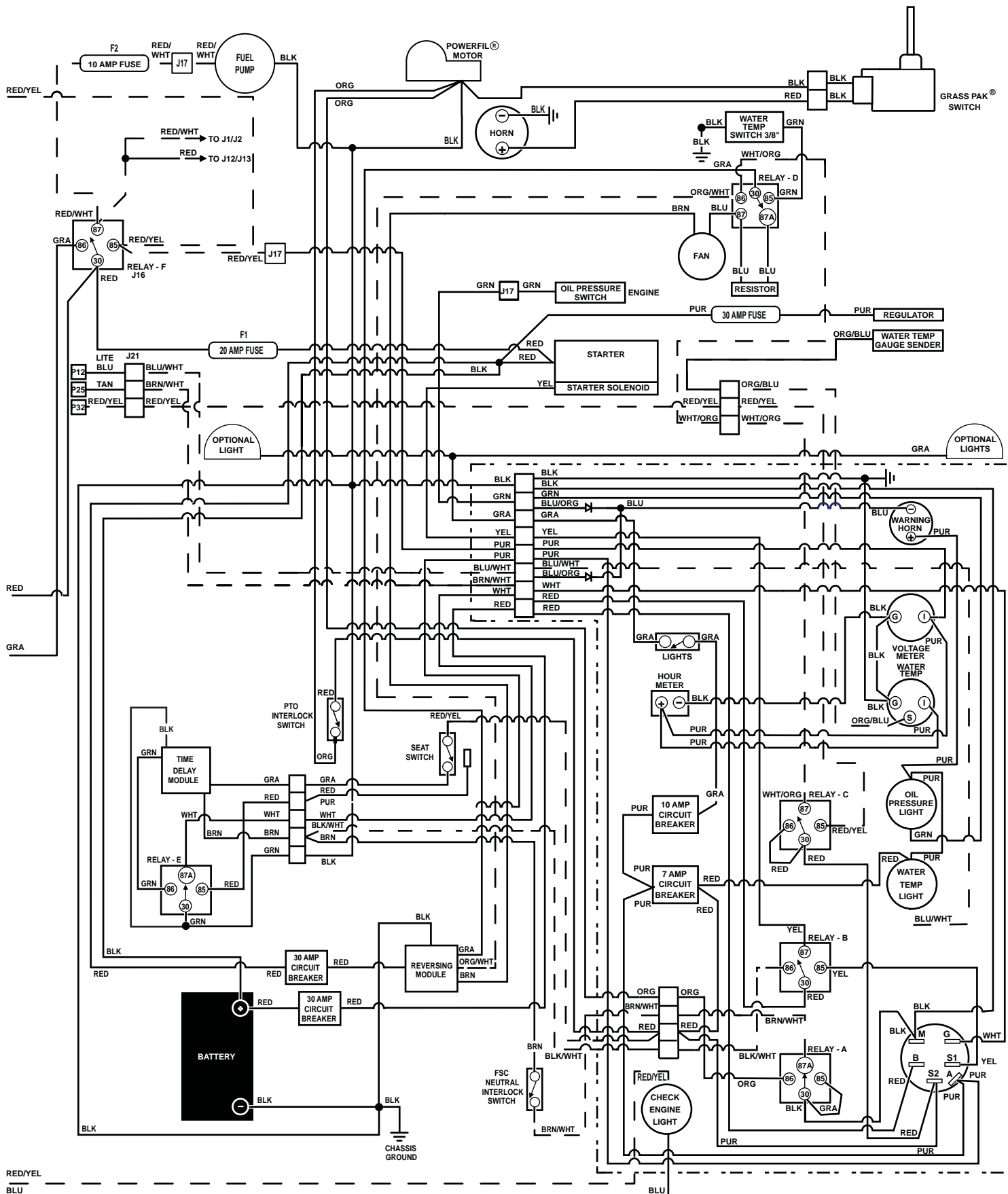

OPERATOR'S NOTES

LIMITED WARRANTY FOR WALKER COMMERCIAL RIDER MOWER

1. WHAT THIS WARRANTY COVERS, AND FOR HOW LONG:

Walker Manufacturing company will, at its option, repair or replace, without charge, any part covered by this warranty which is found to be defective in material and/or workmanship within one (1) year* after date of sale to the original retail purchaser unless the product is used for rental purposes, in which case this warranty is limited to ninety (90) days. At Walker's request, customer will make the defective part available for inspection by Walker and/or return the defective part to Walker, transportation charges prepaid. All parts and components of the Walker Mower are covered by this warranty **except** the following components which are warranted separately by their respective manufacturers:

Kohler Engine
Kubota Engine
Kawasaki Engine
Eaton Hydraulic Transmission
Peerless Gearboxes
Battery
Tires

The available warranties covering these items are furnished with each mower. Walker does not assume any warranty obligation, liability or modification for these items, which are covered exclusively by the stated warranty of the respective manufacturers noted above.

* An extended three (3) year warranty is offered on the Walker P/N 6200-9 Gear Axle Assembly.

2. WHAT THIS WARRANTY DOES NOT COVER:

- A. This warranty does not cover defects caused by depreciation or damage caused by normal wear, accidents, improper maintenance, improper use or abuse of the product, alterations, or failure to follow the instructions contained in the Owner's Manual for operation and maintenance.
- B. The customer shall pay any charges for making service calls and/or for transporting the mower to and from the place where the inspection and/or warranty work is performed.

3. HOW TO OBTAIN SERVICE UNDER THIS WARRANTY:

Warranty service can be arranged by contacting the dealer where you purchased the mower or by contacting Walker Manufacturing Company, 5925 East Harmony Road, Ft. Collins, CO 80528. Proof of the date of purchase may be required to verify warranty coverage.

4. WARRANTY LIMITATION:

- A. **THERE IS NO OTHER EXPRESS WARRANTY. ANY WARRANTY THAT MAY BE IMPLIED FROM THIS PURCHASE INCLUDING MERCHANTABILITY AND FITNESS FOR A PARTICULAR PURPOSE IS HEREBY LIMITED TO THE DURATION OF THIS WARRANTY AND TO THE EXTENT PERMITTED BY LAW ANY AND ALL IMPLIED WARRANTIES ARE EXCLUDED.** Some states do not allow limitations on how long an implied warranty lasts, so the above limitations may not apply to you.
- B. **WALKER WILL NOT BE LIABLE FOR ANY INCIDENTAL, CONSEQUENTIAL, OR SPECIAL DAMAGES AND/OR EXPENSES IN CONNECTION WITH THE PURCHASE OR USE OF THE MOWER.** Some states do not allow the exclusion or limitation of incidental or consequential damages, so the above limitation(s) or exclusion(s) may not apply to you.
- C. Only the warranty expressed in this limited warranty shall apply and no dealer, distributor, or individual is authorized to amend, modify, or extend this warranty in any way. Accordingly, additional statements such as dealer advertising or presentations, whether oral or written, do not constitute warranties by Walker, and should not be relied upon.
- D. This warranty gives you specific legal rights, and you may also have other rights which vary from state to state.

WALKER MOWERS™

WALKER MFG. CO. • 5925 E. HARMONY ROAD, FORT COLLINS, CO 80528 • (970) 221-5614
FORM NO. 040107 PRINTED IN USA www.walkermowers.com ©2007 WALKER MFG. CO