

# Walker Rider Lawnmowers

## ILLUSTRATED PARTS MANUAL

Model MT (20.0 HP)  
Model MTL (25.0 HP)  
Model MTEFI (26.0 HP)  
Model MTLEFI (31.0 HP)

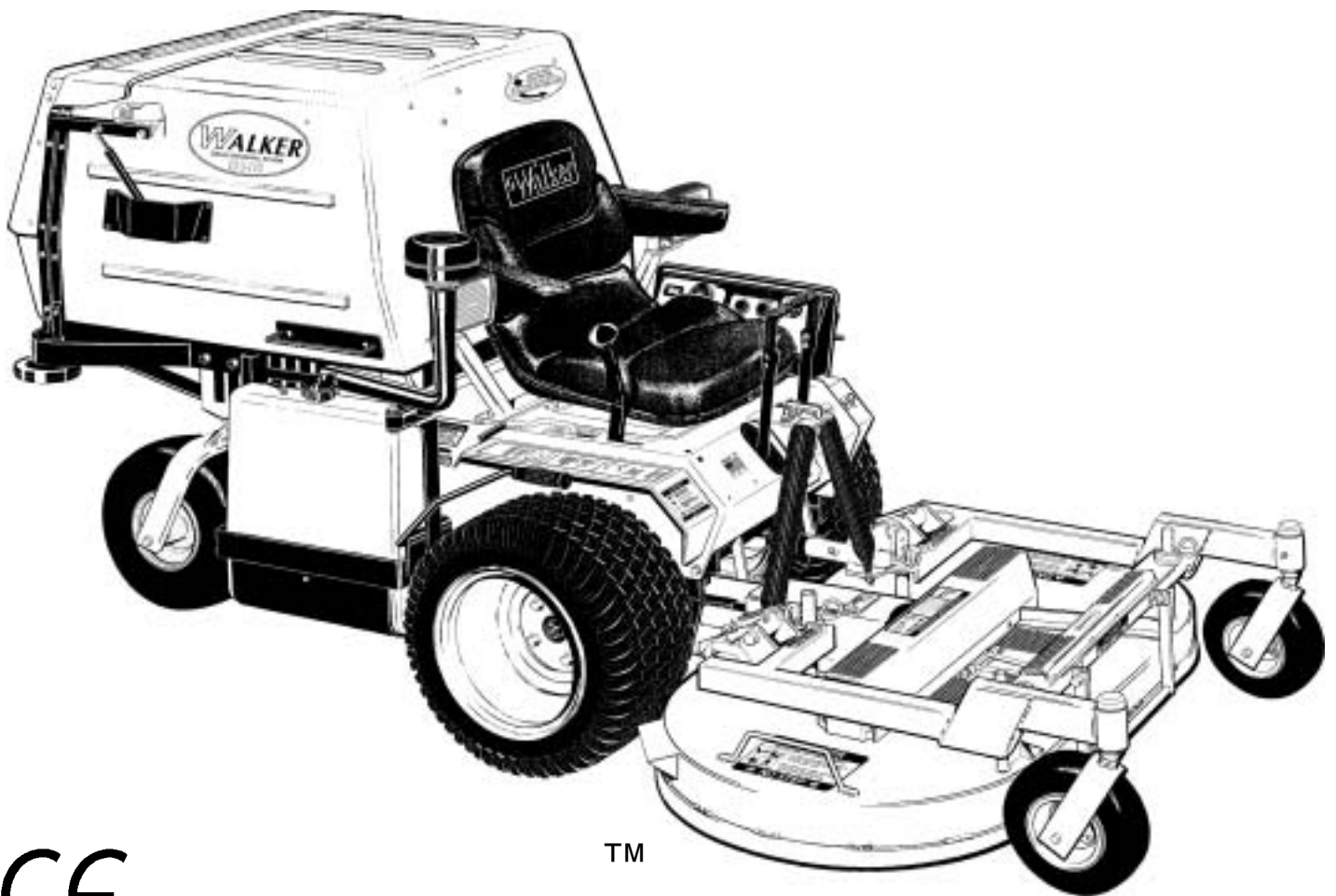

CE

TM

Effective Date:  
09-15-05

P/N 8000-12

# KEY TO ABBREVIATIONS USED IN THIS MANUAL

<i>Abbreviation</i>	<i>What it Represents</i>
° (Dimension)	Degrees (Angle)
" (Dimension)	inches
(-)	Negative (Polarity)
(+)	Positive (Polarity)
AT	All-Terrain
CCW	Counter-clockwise
Conn.	Connector
CW	Clockwise
D	Diameter
DGHS	Deck, Grass Handling System (number refers to size in inches)
DML	Deck, Mulching (number refers to size in inches)
DSD	Deck, Side Discharge (number refers to size in inches)
DU	Garlock (Bearing)
ESNA (Fastener)	Nylon Insert Locknut
FSC	Forward Speed Control
GA	Gauge
gal.	gallon
GHS	Grass Handling System
GR (Fastener)	Grade
HP	Horse Power
HT	Heat-Treated
ID	Identification or Inside Diameter
L	Length
LH	Left Hand (orientated with operator on seat)
LP	Low Profile
mm (Dimension)	millimeters
MS (Fastener)	Machine Screw
NS (as part number)	Item is not sold by Walker Manufacturing
OD	Outside Diameter
oz.	ounce
PFH (Fastener)	Phillips Flat Head
P/N	Part Number
PPH (Fastener)	Phillips Pan Head
PTH (Fastener)	Phillips Truss Head
PTO	Power Take-Off
QKS	Quick Slide
qt.	quart
RH	Right Hand (orientated with operator on seat)
SAE (Fastener)	Society of Automotive Engineers
SBH (Fastener)	Socket Button Head (Bolt)
SD	Side Discharge
SFH (Fastener)	Slotted Flat Head
SHC (Fastener)	Socket Head Cap
SHL (Fastener)	Shoulder (Bolt)
SM (Fastener)	Sheet Metal (Screw)
S/N	Serial Number
Spg.	Spring
SQH (Fastener)	Square Head
SS (Fastener)	Stainless Steel
ST (Fastener)	Self-Tapping (Screw)
Term.	Terminal
V	Volts

**NOTE:** In some instances, combinations of abbreviations may be used (e.g. PPHMS - Phillips Pan Head Machine Screw).

Use only genuine **Walker**<sup>®</sup> replacement parts.

Effective Date 09-15-05

# ILLUSTRATED PARTS LIST

<i>Section of Mower Covered</i>	<i>Page</i>
<b>Decals</b>	
Tractor Decals .....	2
<b>Body / Chassis Assemblies</b>	
Body / Chassis Assembly	
(GHS Models) MT/MTEFI .....	4
(GHS Models) MTL/MTLEFI .....	6
Rear Body Assembly	
(GHS Models) MT/MTEFI .....	8
(GHS Models) MTL/MTLEFI .....	10
Body Assembly	
(SD Models) MT/MTEFI .....	12
(SD Models) MTL/MTLEFI .....	14
<b>Tractor Components</b>	
Main Component Power Transmission	
(GHS Models) .....	16
(SD Models) .....	18
Engine Group	
(MT) .....	20
(MTL) .....	22
(MTEFI) .....	24
(MTLEFI) .....	26
Radiator Group (MTL/MTLEFI) .....	28
Hydrostatic Ground Drive Assemblies .....	30
Steering Control Assemblies .....	32
Throttle & Choke Control Assembly .....	34
Parking Brake Assembly .....	36
GHS Group (MT).....	38
10.5" GHS Blower Group	
(MTL, MTEFI, MTLEFI) .....	40
GHS Powerfil® Assembly .....	42
GHS 7.0 Bushel Catcher & Exhaust Deflector Assemblies .....	44
GHS 9.5 Bushel Catcher Assembly .....	46
Instrument Panel Assembly	
(MT) .....	48
(MTL) .....	50
(MTEFI) .....	52
(MTLEFI) .....	54

<i>Section of Mower Covered</i>	<i>Page</i>
<b>Electrical Components</b>	
Electrical Assembly	
(MT) .....	56
(MTL) .....	58
(MTEFI) .....	60
(MTLEFI) .....	62
Electrical Assemblies	
(GHS 7.0 / 9.5 Bushel Components) .....	64
Electrical Connectors .....	66
<b>Options and Kits</b>	
Power Deck Lift Kit .....	68
Armrest Kit / Touch-Up Paint / Comfort Seat Kit ...	70
Suspension Seat Kit .....	72
Light Kit / Cold Start Kit / Speed Up Kit .....	74
Blower Lockout Kit / Case-Hardened Blower .....	76
Power Dump Kit	
(7.0 Bushel GHS Models Only) .....	78
(9.5 Bushel GHS Models Only) .....	80
Hi-Dump Kit .....	82
Hi-Dump Kit - Hydraulic .....	84
No Catch Deflector Kit / Tail Weight Kit / Spread Tail Wheel Axle Kit .....	86
Tail Wheel Lock Kit .....	88
Wide Tail Wheel / All-Terrain Tire Kit & Tire Chain Set .....	90
<b>Maintenance</b>	
Lubrication Points .....	92
Wiring Schematic	
(MT) .....	94
(MTL) .....	95
(MTEFI) .....	96
(MTLEFI) .....	98
<b>Operator's Notes</b> .....	100
<b>Warranty</b>	
Limited Warranty .....	101

# TRACTOR DECALS

ITEM NO.	PART NO.	DESCRIPTION	LOCATION	NO. REQ'D. GHS	NO. REQ'D SD
<b>Walker Product and Operation Decals</b>					
1	7802	RH Fender	Body, RH Side Near Seat	1	1
2	5856	Made in USA	Body	1	1
3	5803	Walker Manufacturing Logo	Body	1	1
4	5813-1	Powerfil®	7.0 / 9.5 Bushel Catcher, Front	1	0
5	5801	GHS	7.0 / 9.5 Bushel Catcher (one on each side)	2	0
6	5800	Walker Mower (4 x 7-1/2)	Utility Bed (one on each side)	0	2
7	5806	Blade Clutch	Body, RH Side	1	1
<b>Danger Decals Warning Decals Caution Decals</b>					
8	5804	Danger, Rotating Blower Blades	Body Near Body Chute	1	0
9	7818	Warning, Read Manual	Body	1	1
10	6810	Danger, Engine Exhaust	Engine	1	1
11	5868	Danger, Pinch Point	7.0 / 9.5 Bushel Catcher Mounting Frame Assembly (one on each side)	2	0
12	5844-2	Warning, Electric System	Battery Hold-Down Bar	1**	1**
<b>Maintenance Decals</b>					
13	7809	Parking Brake	Body, RH Side below Seat	1	1
14	7820	Body Release Decal	Body, RH Side	1	1
15	7819	Throttle	Body, LH Side	1	1
16	8819	Choke	Body, LH Side	1	1
17	5855	Important, Engine Cooling	Engine	1	1
18	NS	Sealed Reservoir	Hydrostatic Drives (one on each)	2	2
19	5810-1	Axle Oil Level	Gear Axle Drive Assemblies (one on each)	2	2
20	5819	Blower Maintenance	Blower Housing	1	0
21	6875	PTO Alignment Arrow	Universal Joint Tube Assembly	1	1
22	7827	Oil Level	Jackshaft Support	1	1
23	5874	Push to Release	7.0 / 9.5 Bushel Catcher Safety Latch	1	0
24	8825	Front Body Closure	Rear Cross Member, Body	1	1
25	8821	20 HP	Body	1*	1*
	8822	25 HP	Body	1*	1*
	8822-10	26 HP	Body	1*	1*
	8822-12	31 HP	Body	1*	1*
26	5869	Removable Screen	7.0 / 9.5 Bushel Catcher Removable Screen	1	0
<b>Option Decals (applied only to units with corresponding Options installed)</b>					
27	7633	Power Dump Switch	Body	1	0
28	8555	Tail Lock Switch	FSC Lever Assembly - Switch Mount Bracket	1	1
29	8654	Power Deck Lift Switch	Body, RH Side	1	1
	8500-8	No Catch Deflector	7.0 / 9.5 Bushel No Catch Deflector, LH Side (Refer to 7.0 / 9.5 Bushel No Catch Deflector Kit Listing)	1	0
30	8400-6	Danger, Body Latch	Body	1***	0

\* 20 HP Decal is Standard. 25 HP Decal furnished only with 25 HP Engine Upgrade Option.  
26 HP Decal furnished only with Optional 26 HP EFI Engine. 31 HP Decal furnished only with MTLEFI Option.

\*\* Decal furnished only with fuel-injected models.

\*\*\* Used only with Hi-Dump Option.

**NOTE:** All parts requiring decals are shipped with decals applied.

Use only genuine **Walker®** replacement parts.

Effective Date 09-15-05



# TRACTOR DECALS

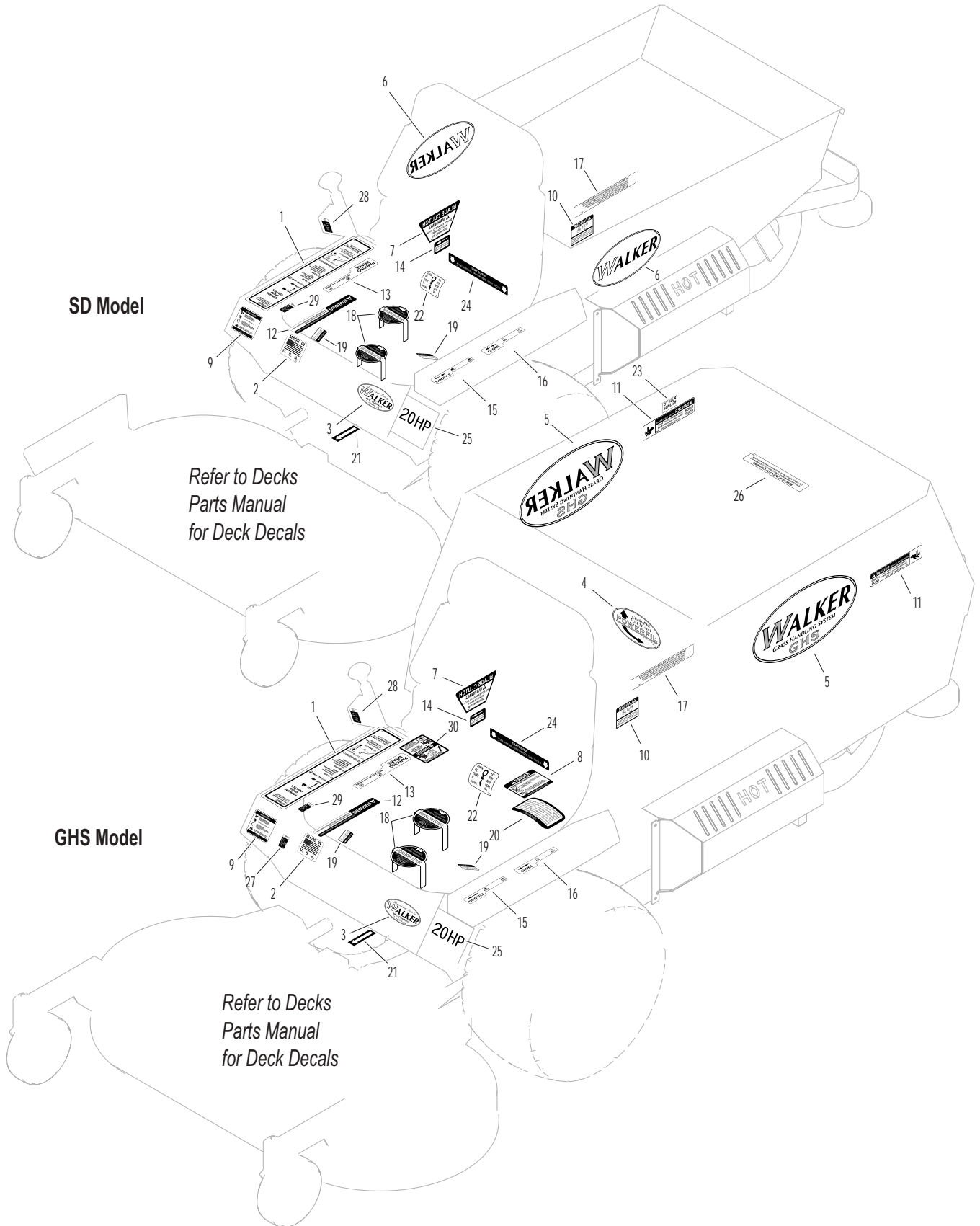

## BODY / CHASSIS ASSEMBLY (GHS MODELS) MT/MTEFI

ITEM NO.	PART NO.	DESCRIPTION	NO. REQ'D	ITEM NO.	PART NO.	DESCRIPTION	NO. REQ'D
<b>Seat Assembly</b>				44	8038-1	Spacer, Tail Wheel Axle	2
1	5103	Seat	1	45	8037	Bearing Cone (3/4 ID)	4
2	7203	Seat Spring Plate	1	46	8035	Tail Wheel & Tire Assembly (13 x 5.00-6) (With Bearing Race)	2
3	7223	Compression Spring (1/2 x 1)	2		7035-1	Tail Wheel Tire (13 x 5.00-6)	**
4	7845	Rubber Bumper (1.375 OD x .63)	2		8036	Wheel & Hub (6 x 3.25) (Includes Item # 41 & Bearing Race)	**
5	7846	Washer (3/8 ID x 1-1/4 OD x 1/8)	2		8037-2	Bearing Race	**
6	7204	Shoulder Bolt, Seat Mount	2	47	8768-2	Seal, Reverse Lip	2
7	7440-5	Shock Mount (1-1/4 x 3/4)	2	48	8038	Tail Wheel Axle (3/4 x 10-3/8)	1
<b>Rear Bumper Assembly (GHS Models Only)*</b>				49	7070	Wheel & Tire Assembly (18 x 9.5-8)	2
8	7516	7.0 / 9.5 Rear Bumper	1		7070-1	Drive Tire (18 x 9.5-8)	**
9	7516-5	Catcher Pivot Bushing	2		5070-4	Wide Wheel (8 x 7)	**
10	5162	Roller Wheel (5" Rubber)	2	50	8300-3	Chassis Frame (T/5.0 gal.)	1
11	7517-2	Catcher Pivot Plate	2		8300-12	Chassis Frame (EFI/5.0 gal.)	1
<b>Body Assembly</b>				<b>Fasteners</b>			
12	NS	Body ID Plate	1	F002	10-24 Keps Nut		2
13	5845	Rubber Bumper (1.50 OD x 1.25)	4	F004	1/4-20 Keps Nut		2
14	8118	Heat Deflector	1	F005	1/4-20 ESNA Nut		1
15	7422	Panel Guard	1	F009	5/16-18 Whiz Locknut		11
16	5989-4	Dome Plug (3/8)	4	F012	3/8-16 Keps Nut		8
17	5989-3	Dome Plug (5/16)	2	F013	3/8-16 Whiz Locknut		2
18	7146	13mm Ball Stud	2	F014	3/8-16 ESNA Nut		4
19	7844	Rubber Bumper (1.25 OD x .25)	1	F020	5/16-18 ESNA Nut		1
20	7147	Spring Clip	2	F025	10-24 x 3/8 PPHMS		2
21	7145	Gas Spring Assembly (Includes Items # 18 & 20)	1	F029	1/4-20 x 1/2 Hex Bolt		2
22	7222	Extension Spring (1/4 x 3)	1	F031	1/4-20 x 5/8 Hex Bolt		1
23	7383-1	Body Latch Hook	1	F034	5/16-18 x 3/4 Hex Bolt		2
24	7854	Plastic Tip, Red	1	F038	3/8-16 x 1 Hex Bolt		6
25	5989-9	Dome Plug (1/4)	10	F040	3/8-16 x 1-1/2 Hex Bolt		2
26	8100	Front Body / T	1	F042	3/8-16 x 2-1/4 Hex Bolt		2
	8100-10	Front Body / EFI	1	F050	1/4 SAE Washer		1
27	5180	Edge Molding, Lever Opening	2	F051	3/8 SAE Washer		2
28	5989-55	Dome Plug (1/2)	1	F059	3/8 Wave Spring Washer		2
29	5989-5	Dome Plug (7/16)	1	F093	5/16-18 x 1 Hex Bolt		1
<b>Tilt-Up Latch Assembly***</b>				F151	3/8-16 x 7/8 Hex Bolt		2
30	5847	Plastic Tip	1	F157	1/2-20 x 1-1/4 Wheel Lug Bolt		8
31	5744-20	Spring Arm, Tilt-Up Latch	1	F205	5/16-18 x 1/4 Set Screw, Knurl Point		2
32	5744-10	Spring Pivot Bushing	1	F206	#2 x 3/16 Drive Pin		2
33	5744-15	Compression Spring (3/8 x 5/8)	1	F218	7/16 Split Lock Washer		2
34	5744-13	Mount Angle, LH	1	F219	7/16-14 x 1-1/4 Hex Bolt		2
35	5744-12	Hook, Tilt-Up Latch	1	F227	3/8 x 1-1/4 x 1/8 Plastic Washer		2
36	5744-14	Mount Angle, RH	1	F241	.375 x .875 x .10 Washer		4
<b>Chassis Assembly</b>				F341	Coil Roll Pin (7/64 x 9/16)		1
37	5267-1	Retainer Collar (1") (Includes Item # F413)	1	F342	5/16 Conical Washer		2
38	5270-1	Pivot Bearing	2	F413	5/16-24 x 5/16 Set Screw		2
39	5842-1	Washer, Axle Spacer	1	* Rear Bumper Assembly for SD Models is not shown here. Refer to <b>BODY ASSEMBLY (SD MODELS) MT/MTEFI</b> , Page 12.			
40	7420	Tail Wheel Fork	1	** Service Part Only			
41	5830-3	Grease Fitting (45 Degree)	2	*** Complete Tilt-Up Latch Assembly Kit available by ordering kit # 5747.			
42	8039	Nut, Tail Wheel Axle	2				
43	8037-1	Seal, Outer (1-3/4 x 1-1/8)	2				

Use only genuine **Walker**<sup>®</sup> replacement parts.

Effective Date 09-15-05

# BODY / CHASSIS ASSEMBLY (GHS MODELS) MT/MTEFI

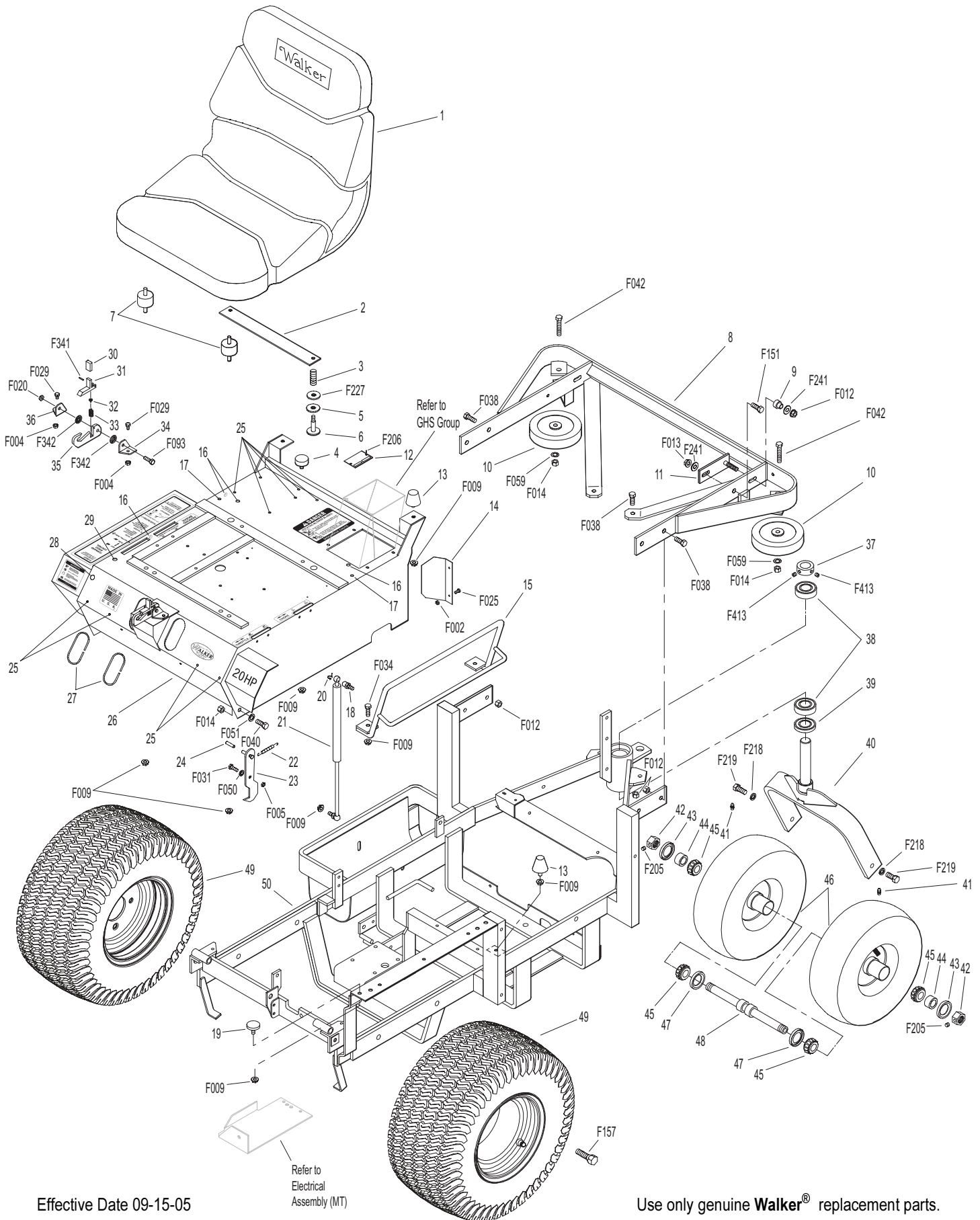

Effective Date 09-15-05

Refer to  
Electrical  
Assembly (MT)

Use only genuine Walker® replacement parts.

# BODY / CHASSIS ASSEMBLY (GHS MODELS) MTL/MTLEFI

ITEM NO.	PART NO.	DESCRIPTION	NO. REQ'D	ITEM NO.	PART NO.	DESCRIPTION	NO. REQ'D
<b>Seat Assembly</b>				45	8037	Bearing Cone (3/4 ID)	4
1	5103	Seat	1	46	8035	Tail Wheel & Tire Assembly (13 x 5.00-6) (With Bearing Race)	2
2	7203	Seat Spring Plate	1		7035-1	Tail Wheel Tire (13 x 5.00-6)	**
3	7223	Compression Spring (1/2 x 1)	2		8036	Wheel & Hub (6 x 3.25) (Includes Item # 41 & Bearing Race)	**
4	7845	Rubber Bumper (1.375 OD x .63)	2		8037-2	Bearing Race	**
5	7846	Washer (3/8 ID x 1-1/4 OD x 1/8)	2	47	8768-2	Seal, Reverse Lip	2
6	7204	Shoulder Bolt, Seat Mount	2	48	8038	Tail Wheel Axle (3/4 x 10-3/8)	1
7	7440-5	Shock Mount (1-1/4 x 3/4)	2	49	7070	Wheel & Tire Assembly (18 x 9.5-8)	2
<b>Rear Bumper Assembly (GHS Models Only)*</b>					7070-1	Drive Tire (18 x 9.5-8)	**
8	7516-7	7.0 / 9.5 Rear Bumper	1		5070-4	Wide Wheel (8 x 7)	**
9	7516-5	Catcher Pivot Bushing	2	50	8300-4	Chassis Frame	1
10	5162	Roller Wheel (5" Rubber)	2	<b>Fasteners</b>			
11	7517-2	Catcher Pivot Plate	2		F002	10-24 Keps Nut	2
<b>Body Assembly</b>					F004	1/4-20 Keps Nut	2
12	NS	Body ID Plate	1		F005	1/4-20 ESNA Nut	1
13	5845	Rubber Bumper (1.50 OD x 1.25)	4		F009	5/16-18 Whiz Locknut	11
14	8118	Heat Deflector	1		F012	3/8-16 Keps Nut	8
15	7422	Panel Guard	1		F013	3/8-16 Whiz Locknut	2
16	5989-4	Dome Plug (3/8)	4		F014	3/8-16 ESNA Nut	4
17	5989-3	Dome Plug (5/16)	2		F020	5/16-18 ESNA Nut	1
18	7146	13mm Ball Stud	2		F025	10-24 x 3/8 PPHMS	2
19	7844	Rubber Bumper (1.25 OD x .25)	1		F029	1/4-20 x 1/2 Hex Bolt	2
20	7147	Spring Clip	2		F031	1/4-20 x 5/8 Hex Bolt	1
21	7145	Gas Spring Assembly (Includes Items # 18 & 20)	1		F034	5/16-18 x 3/4 Hex Bolt	2
22	7222	Extension Spring (1/4 x 3)	1		F038	3/8-16 x 1 Hex Bolt	6
23	7383-1	Body Latch Hook	1		F040	3/8-16 x 1-1/2 Hex Bolt	2
24	7854	Plastic Tip, Red	1		F042	3/8-16 x 2-1/4 Hex Bolt	2
25	5989-9	Dome Plug (1/4)	10		F050	1/4 SAE Washer	1
26	8100-1	Front Body / MTL	1		F051	3/8 SAE Washer	2
	8100-3	Front Body / MTLEFI	1		F059	3/8 Wave Spring Washer	2
27	5180	Edge Molding, Lever Opening	2		F093	5/16-18 x 1 Hex Bolt	1
28	5989-55	Dome Plug (1/2)	1		F151	3/8-16 x 7/8 Hex Bolt	2
29	5989-5	Dome Plug (7/16)	1		F157	1/2-20 x 1-1/4 Wheel Lug Bolt	8
<b>Tilt-Up Latch Assembly***</b>					F191	3/8 x 1-1/2 x 3/16 Washer	2
30	5847	Plastic Tip	1		F205	5/16-18 x 1/4 Set Screw, Knurl Point	2
31	5744-20	Spring Arm, Tilt-Up Latch	1		F206	#2 x 3/16 Drive Pin	2
32	5744-10	Spring Pivot Bushing	1		F218	7/16 Split Lock Washer	2
33	5744-15	Compression Spring (3/8 x 5/8)	1		F219	7/16-14 x 1-1/4 Hex Bolt	2
34	5744-13	Mount Angle, LH	1		F227	3/8 x 1-1/4 x 1/8 Plastic Washer	2
35	5744-12	Hook, Tilt-Up Latch	1		F241	.375 x .875 x .10 Washer	4
36	5744-14	Mount Angle, RH	1		F341	Coil Roll Pin (7/64 x 9/16)	1
<b>Chassis Assembly</b>					F342	5/16 Conical Washer	2
37	5267-1	Retainer Collar (1") (Includes Item # F413)	1		F413	5/16-24 x 5/16 Set Screw	2
38	5270-1	Pivot Bearing	2	* Rear Bumper Assembly for SD Models is not shown here. Refer to <b>BODY ASSEMBLY (SD MODELS) MTL/MTLEFI</b> , Page 14.			
39	5842-1	Washer, Axle Spacer	1	** Service Part Only			
40	7420	Tail Wheel Fork	1	*** Complete Tilt-Up Latch Assembly Kit available by ordering kit # 5747.			
41	5830-3	Grease Fitting (45 Degree)	2				
42	8039	Nut, Tail Wheel Axle	2				
43	8037-1	Seal, Outer (1-3/4 x 1-1/8)	2				
44	8038-1	Spacer, Tail Wheel Axle	2				

Use only genuine **Walker**<sup>®</sup> replacement parts.

Effective Date 09-15-05

# BODY / CHASSIS ASSEMBLY (GHS MODELS) MTL/MTLEFI

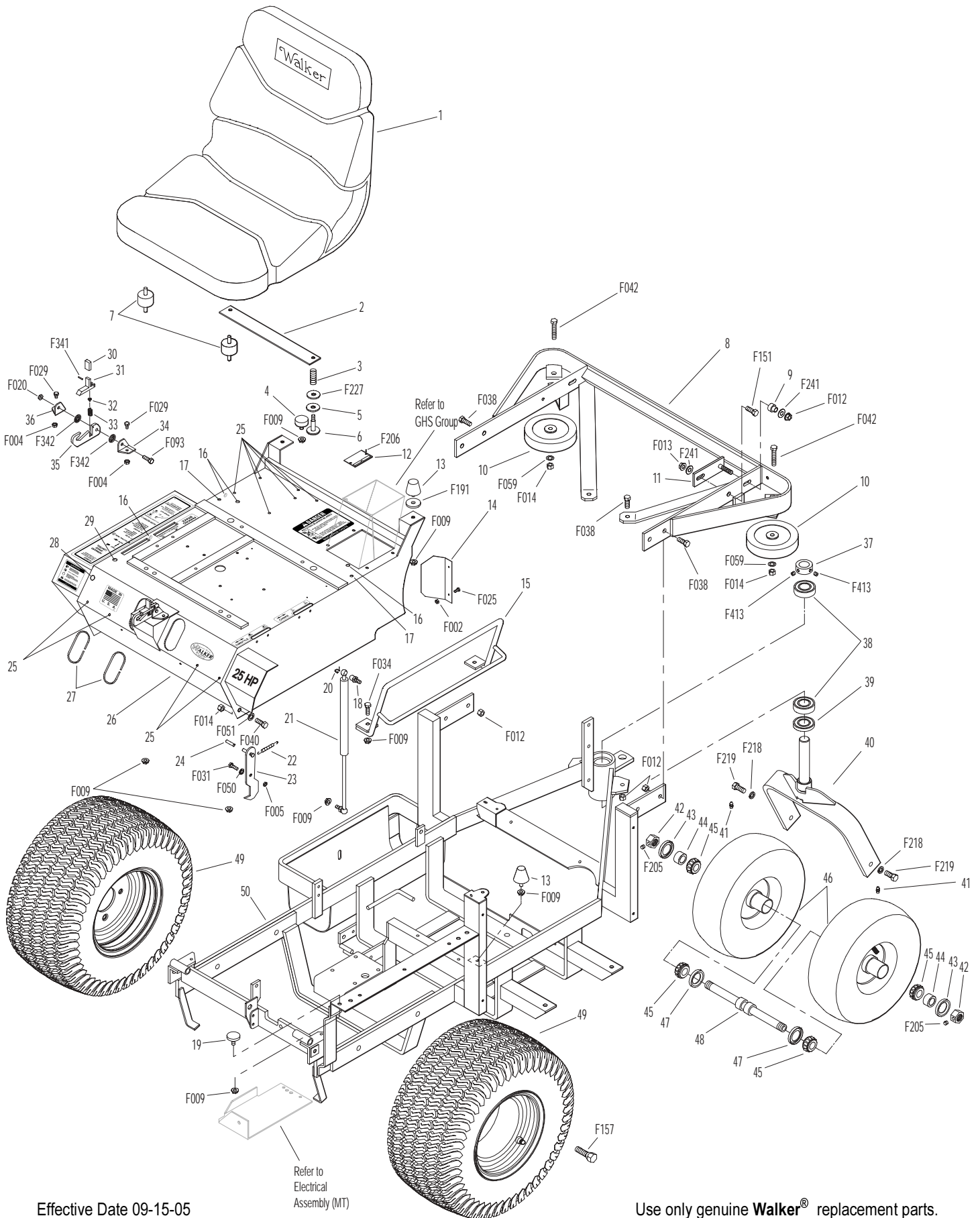

Effective Date 09-15-05

Refer to  
Electrical  
Assembly (MT)

Use only genuine Walker® replacement parts.

## REAR BODY ASSEMBLY (GHS MODELS) MT/MTEFI

ITEM NO.	PART NO.	DESCRIPTION	NO. REQ'D	ITEM NO.	PART NO.	DESCRIPTION	NO. REQ'D
<b>Rear Body Assembly (GHS Models)</b>				<b>Fasteners</b>			
1	7190-3	Insulation Foam Pad (5 x 20)	1	F002		10-24 Keps Nut	14
2	8082	Heat Shield	1	F004		1/4-20 Keps Nut	5
3	8515-10	Catcher Reinforcing Plate	2	F009		5/16-18 Whiz Locknut	2
4	8515-3	Catcher Support Frame	1	F025		10-24 x 3/8 PPHMS	8
5	7190-2	Insulation Foam Pad, RH	1	F026		10-24 x 1/2 PPHMS	5
6	7190-1	Insulation Foam Pad, LH	1	F027		10-24 x 5/8 PPHMS	1
7	7145	Gas Spring Assembly (Includes Items # 9 & 10)	1	F031		1/4-20 x 5/8 Hex Bolt	2
8	8389-2	Splash Guard with Mat	1	F032		1/4-20 x 3/4 Hex Bolt	1
9	7147	Spring Clip	2	F085		3/16 Rivet Backup Washer	2
10	7146	13mm Ball Stud	2	F178		1/4 x 1 Fender Washer	1
11	8105-1	Rear Body Panel	1	F390		1/4-20 x 7/8 Carriage Bolt	2
12	8389-12	Rubber Mat (3 x 3)	1				

**NOTE:** Rear Bumper Assembly for GHS Models is not shown here. Refer to **BODY / CHASSIS ASSEMBLY (GHS MODELS) MT/MTEFI**, Page 4.

# REAR BODY ASSEMBLY (GHS MODELS) MT/MTEFI

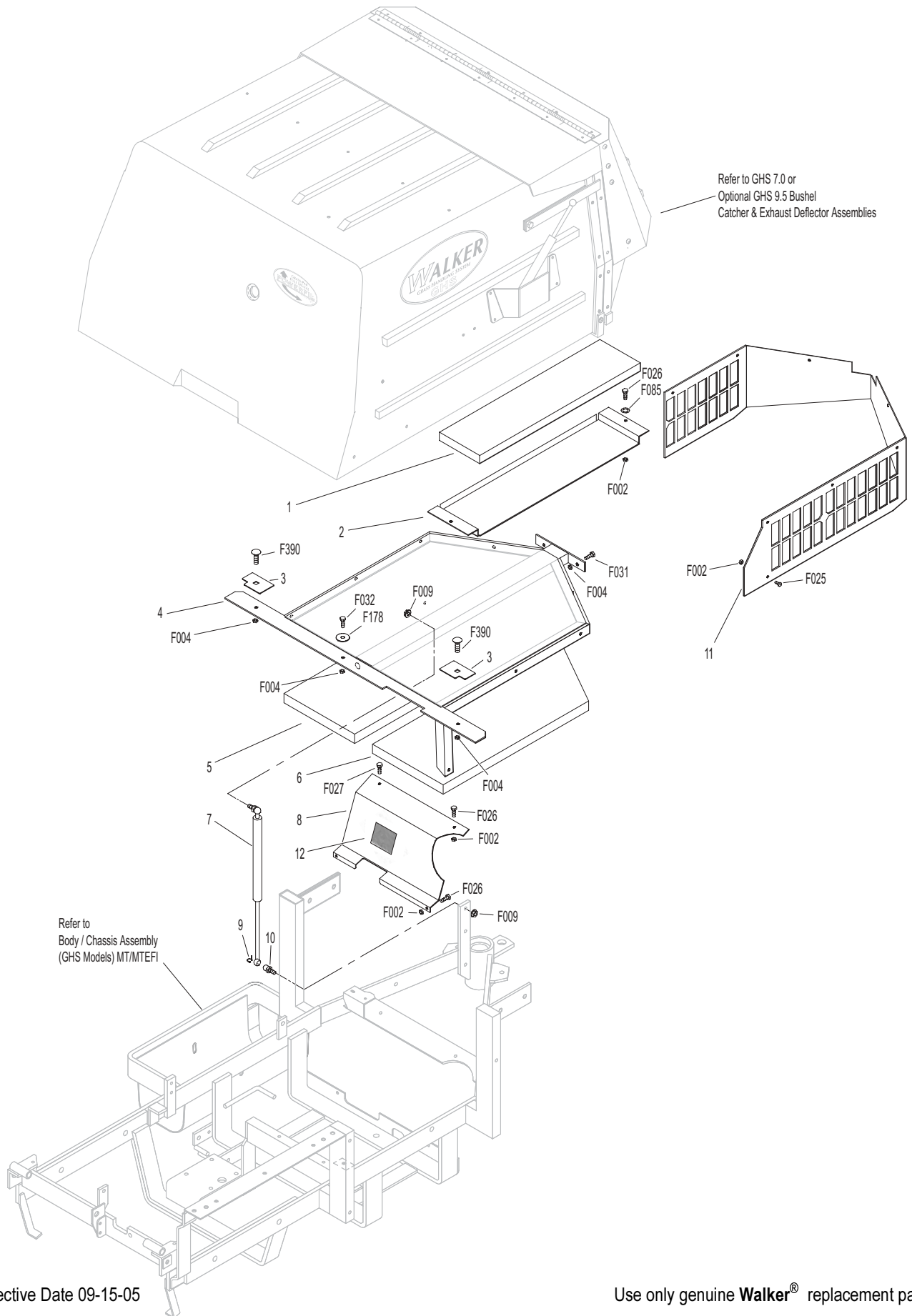

Effective Date 09-15-05

Use only genuine Walker® replacement parts.

## REAR BODY ASSEMBLY (GHS MODELS) MTL/MTLEFI

ITEM NO.	PART NO.	DESCRIPTION	NO. REQ'D	ITEM NO.	PART NO.	DESCRIPTION	NO. REQ'D
<b>Rear Body Assembly (GHS Models)</b>				<b>Fasteners</b>			
1	8515-10	Catcher Reinforcing Plate	2	F002		10-24 Keps Nut	11
2	8515-4	Catcher Support Frame	1	F004		1/4-20 Keps Nut	5
3	7190-2	Insulation Foam Pad, RH	1	F009		5/16-18 Whiz Locknut	2
4	7190-1	Insulation Foam Pad, LH	1	F025		10-24 x 3/8 PPHMS	5
5	7145	Gas Spring Assembly (Includes Items # 7 & 8)	1	F026		10-24 x 1/2 PPHMS	6
6	8389-3	Splash Guard	1	F027		10-24 x 5/8 PPHMS	1
7	7147	Spring Clip	2	F031		1/4-20 x 5/8 Hex Bolt	2
8	7146	13mm Ball Stud	2	F032		1/4-20 x 3/4 Hex Bolt	1
9	8082-1	Heat Shield	1	F085		3/16 Rivet Backup Washer	3
10	7190-4	Insulation Foam Pad/GHS	1	F178		1/4 x 1 Fender Washer	1
11	8105-16	Rear Body Panel	1	F390		1/4-20 x 7/8 Carriage Bolt	2

**NOTE:** Rear Bumper Assembly for GHS Models is not shown here. Refer to **BODY / CHASSIS ASSEMBLY (GHS MODELS) MTL/MTLEFI**, Page 6.



# REAR BODY ASSEMBLY (GHS MODELS) MTL/MTLEFI

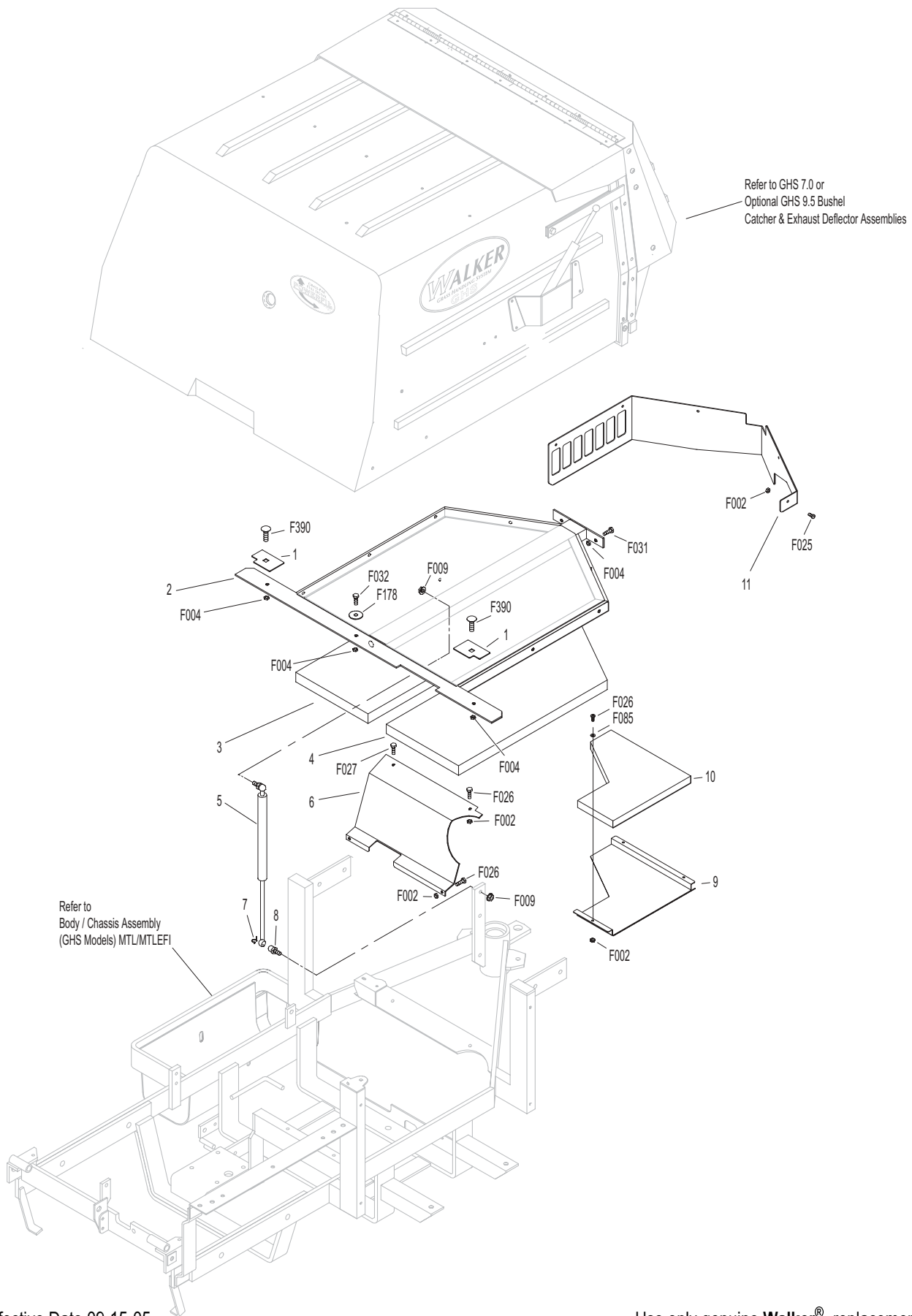

Effective Date 09-15-05

Use only genuine Walker® replacement parts.

## BODY ASSEMBLY (SD MODELS) MT/MTEFI

ITEM NO.	PART NO.	DESCRIPTION	NO. REQ'D	ITEM NO.	PART NO.	DESCRIPTION	NO. REQ'D
<b>Utility Bed Assembly</b>				<b>Fasteners</b>			
1	8650-10	Bed Liner (21.5 x 27.5)	1	F002		10-24 Keps Nut	16
2	8650-2	Utility Bed (Includes Item # 1)	1	F009		5/16-18 Whiz Locknut	2
3	7190-2	Insulation Foam Pad, RH	1	F012		3/8-16 Keps Nut	6
4	7190-1	Insulation Foam Pad, LH	1	F013		3/8-16 Whiz Locknut	4
<b>Rear Bumper Assembly (SD Models)</b>				F014		3/8-16 ESNA Nut	2
5	7153-3	Cover Plate	1	F025		10-24 x 3/8 PPHMS	8
6	7145	Gas Spring Assembly (Includes Items # 7 & 8)	1	F026		10-24 x 1/2 PPHMS	3
7	7147	Spring Clip	2	F027		10-24 x 5/8 PPHMS	1
8	7146	13mm Ball Stud	2	F038		3/8-16 x 1 Hex Bolt	6
9	7521	Rear Bumper	1	F040		3/8-16 x 1-1/2 Hex Bolt	2
10	5162	Roller Wheel (5" Rubber)	2	F042		3/8-16 x 2-1/4 Hex Bolt	2
11	8105-1	Rear Body Panel	1	F051		3/8 SAE Washer	4
12	8389-2	Splash Guard W/Mat	1	F059		3/8 Wave Spring Washer	2
13	8389-12	Rubber Mat (3 x 3)	1	F128		10-24 x 3/8 PTHMS	4

**NOTE:** Refer to **BODY / CHASSIS ASSEMBLY (GHS MODELS) MT/MTEFI**, Page 4 for all common parts used on both models.

# BODY ASSEMBLY (SD MODELS) MT/MTEFI

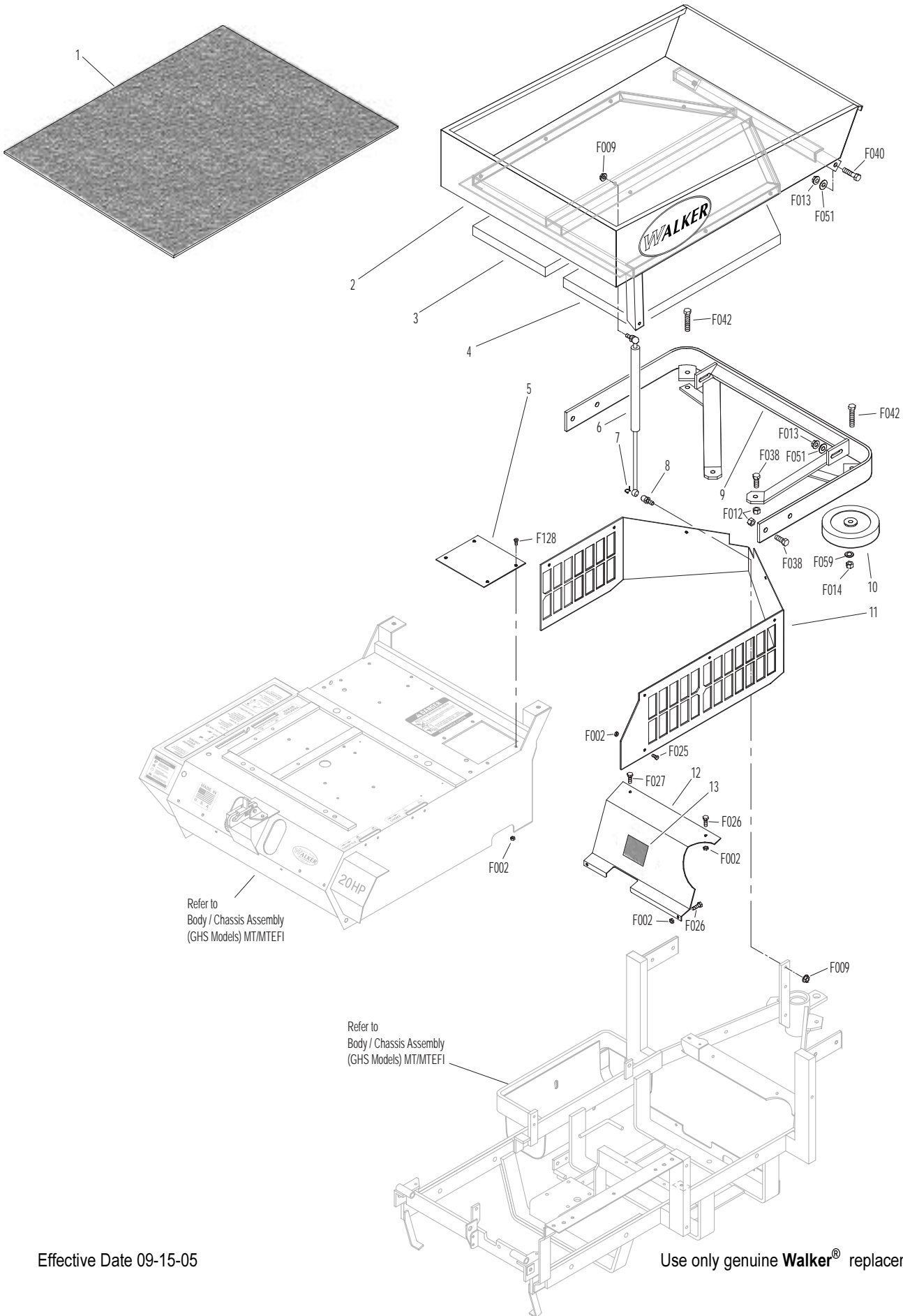

Effective Date 09-15-05

Use only genuine Walker® replacement parts.

## BODY ASSEMBLY (SD MODELS) MTL/MTLEFI

ITEM NO.	PART NO.	DESCRIPTION	NO. REQ'D	ITEM NO.	PART NO.	DESCRIPTION	NO. REQ'D
<b>Utility Bed Assembly</b>				<b>Fasteners</b>			
1	8650-10	Bed Liner (21.5 x 27.5)	1	F002		10-24 Keps Nut	13
2	8650-3	Utility Bed	1	F009		5/16-18 Whiz Locknut	2
3	7190-2	Insulation Foam Pad, RH	1	F012		3/8-16 Keps Nut	6
4	7190-1	Insulation Foam Pad, LH	1	F013		3/8-16 Whiz Locknut	4
<b>Rear Bumper Assembly (SD Models)</b>				F014		3/8-16 ESNA Nut	2
5	7153-3	Cover Plate	1	F025		10-24 x 3/8 PPHMS	5
6	7145	Gas Spring Assembly (Includes Items # 7 & 8)	1	F026		10-24 x 1/2 PPHMS	3
7	7147	Spring Clip	2	F027		10-24 x 5/8 PPHMS	1
8	7146	13mm Ball Stud	2	F038		3/8-16 x 1 Hex Bolt	6
9	7521-5	Rear Bumper	1	F040		3/8-16 x 1-1/2 Hex Bolt	2
10	5162	Roller Wheel (5")	2	F042		3/8-16 x 2-1/4 Hex Bolt	2
11	8105-16	Rear Body Panel	1	F051		3/8 SAE Washer	4
12	8389-3	Splash Guard	1	F059		3/8 Wave Spring Washer	2
				F128		10-24 x 3/8 PTHMS	4

**NOTE:** Refer to **BODY / CHASSIS ASSEMBLY (GHS MODELS) MTL/MTLEFI**, Page 6 for all common parts used on both models.

# BODY ASSEMBLY (SD MODELS) MTL/MTLEFI

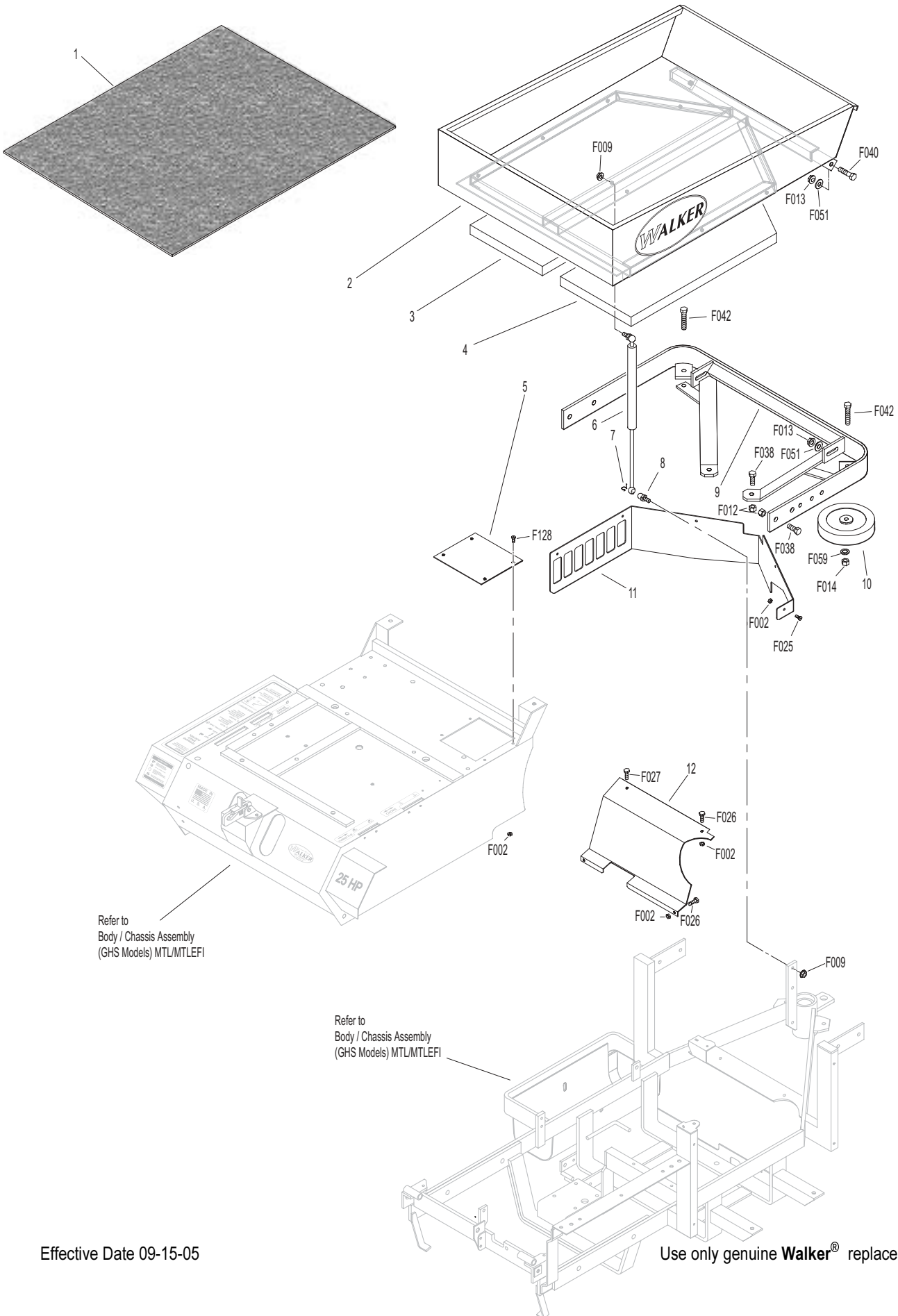

Refer to  
Body / Chassis Assembly  
(GHS Models) MTL/MTLEFI

Refer to  
Body / Chassis Assembly  
(GHS Models) MTL/MTLEFI

Effective Date 09-15-05

Use only genuine Walker® replacement parts.

# MAIN COMPONENT POWER TRANSMISSION (GHS MODELS)

ITEM NO.	PART NO.	DESCRIPTION	NO. REQ'D	ITEM NO.	PART NO.	DESCRIPTION	NO. REQ'D
<b>Clutch Lever Assembly</b>				44	5268	Bearing W/Collar (3/4)	2
1	8358	Clutch Lever (Includes Items # 2 & 3)	1	45	7241-2	Transmission Drive Pulley (3-1/4/MV) (Includes Items # F067 & F171)	1
2	5830	Grease Fitting	7				
3	7860	Handle Grip	1	46	7833	Cable Clamp (7/8 x 1/4)	1
4	7303-10	Clutch Actuator Bolt (3/8)	1	47	7394-6	Idler Pulley Spring Mount	1 <sup>Δ</sup>
5	7380-5	Knuckle Joint (3/8 ID)	1	48	8349	Transmission Belt Tightener Arm	1
6	7226-10	Compression Spring (3/4 x 2-1/2)	1	49	8393-7	Hydro Jackshaft Mount	1
7	8130-5	Push Rod, Clutch Actuator (Threaded Tube)	1		8394-1	Hydro Jackshaft Mount Assembly (Includes Items # 2, 9, 41, 44, 49 & 50)	*
8	8130-10	Clutch Actuator Rod Assembly (Includes Items # 2, 4-7, F054, F336 & F353)	1	50	8273	Jackshaft (3/4 x 7-1/2)	1
9	7201-3	DU Bearing	6	51	7240-3	Jackshaft Drive Pulley (4.15/3V) (Includes Items # F067 & F171)	1
10	7201-5	Inner Race (2-1/4)	1	52	7240-4	Jackshaft Drive Pulley (3.3/3V) (Includes Items # F067 & F171)	1**
11	8368	PTO Belt Tightener	1				
12	5841	Retainer Washer (3/8 x 1-1/4)	4	53	8349-3	Idler Arm, MTLEFI	1***
13	8243	Clutch Idler Pulley Assembly (Includes Items # 14, 15 & F070)	1	<b>Fasteners</b>			
	8243-1	Clutch Idler Pulley	1		F003	1/4-28 Hex Nut	2
14	5265	Bearing (3/4)	1		F004	1/4-20 Keps Nut	3
15	8243-3	Hub, Idler Pulley	1		F005	1/4-20 ESNA Nut	1
16	8375	PTO Belt Tightener Stop	1		F009	5/16-18 Whiz Locknut	3
17	7377	Plastic Washer (7/16 x 1 x .025)	2		F012	3/8-16 Keps Nut	8
18	7378	Pivot Bearing (7/16 x 9/16)	1		F029	1/4-20 x 1/2 Hex Bolt	1
19	5281-5	Clevis Pin (1/4 x 0.80)	2		F040	3/8-16 x 1-1/2 Hex Bolt	1
20	5280	Clevis (1/4)	2		F041	3/8-16 x 1-3/4 Hex Bolt	2
21	8305	Brake Actuator Rod	1		F042	3/8-16 x 2-1/4 Hex Bolt	3
22	8370	Bearing, Brake Actuator	1		F043	3/8-16 x 3 Hex Bolt	1
23	8250	Brake Spring (1/2 x 2-1/2)	1		F047	3/8-16 x 4-1/2 Hex Bolt	1
24	8369	Brake Actuator (Includes Items # 2 & 22)	1		F054	AN960616 Washer	3
<b>PTO Drive Shaft Assembly</b>					F061	1/4 Internal Star Lock Washer	1
25	7050-1	Dipstick, Gearbox	1		F067	3/16 x 3/16 x 1 Key	2
26	8371-1	Mount Bracket, Brake Band	1		F069	3/32 x 1/2 Cotter Pin	2
27	8377	Brake Band Guide	1		F070	1-3/4 Internal Snap Ring	1
28	8050-11	PTO Gearbox / Flange Pulley	1		F090	1/4-20 x 2-1/2 Hex Bolt	1
29	5245	Idler Pulley (3")	2		F116	1/4-20 x 1-1/4 Hex Bolt	1
30	7248	Ground Drive Belt, Micro-V	1		F121	5/16-18 x 3/8 x 1 SHL Bolt	1
31	7275-16	Universal Joint Tube Assembly/Spline	1		F131	5/16-18 x 1/2 Hex Bolt	2
32	7523-2	Clevis Pin (1/4 x 5/8)	1		F132	1/4-20 x 2-3/4 Hex Bolt	1
33	8304	Brake Band (14-1/2)	1		F168	5/16 Split Lock Washer	14
34	6250	Drive Belt (3VX375)	1		F171	5/16-18 x 3/8 Set Screw	4
35	7236-1	PTO Drive Pulley (4-1/2/3V) (Includes Items # F168 & F226)	1		F178	1/4 x 1 Fender Washer	1
36	8237-2	Engine Pulley, Bolt On (4/3.8/3V) (Includes Items # F168 & F226)	1		F182	5/8 x 1/4 x 1/8 Washer	2
37	8230	Engine PTO Belt	1		F186	5/64 x 1/2 Cotter Pin	1
<b>Jackshaft Assembly</b>					F226	5/16-18 x 7/8 Hex Bolt	14
38	7245-1	Idler Pulley (3/8 Groove)	1		F241	.375 x .875 x .10 Washer	1
39	6325-2	Spacer Bushing (5/16)	2		F255	5/16-18 x 1-1/2 Hex Bolt	2
40	8349-2	Idler Arm	1		F261	AN960616L Washer	1
41	7201-4	Inner Race (1-1/2)	2		F336	3/8-16 Jam Nut	1
42	5221	Extension Spring (3/4 x 4)	2		F353	3/8-16 ESNA LP Nut	1
43	8539	Starter Relay Mount	1				
				*	Service Part Only		
				**	Item used on MTL and MTLEFI only		
				***	Item used on MTLEFI only		
				Δ	Item used on MT only		

Use only genuine **Walker**<sup>®</sup> replacement parts.

Effective Date 09-15-05

# MAIN COMPONENT POWER TRANSMISSION (GHS MODELS)

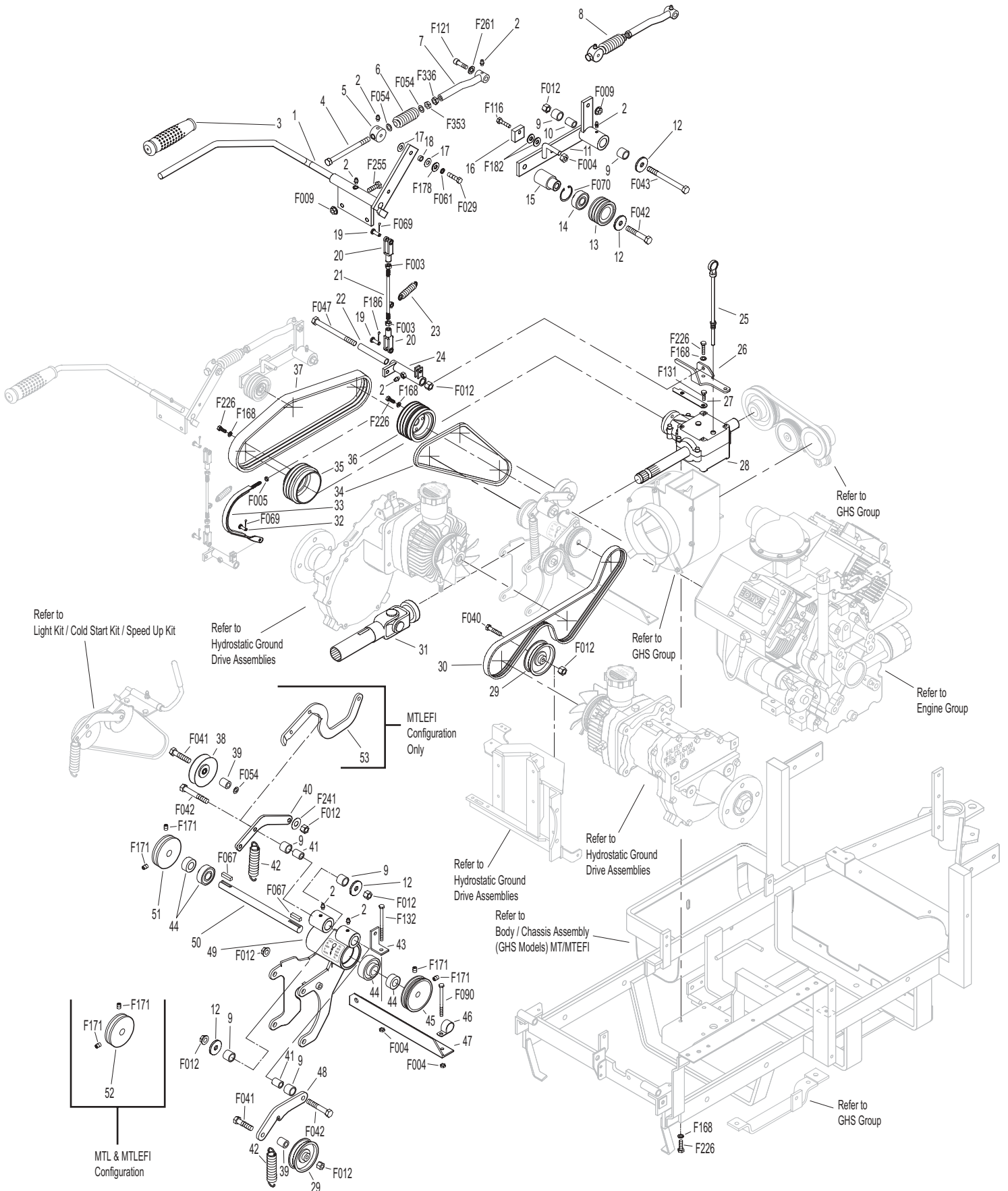

Effective Date 09-15-05

Use only genuine Walker® replacement parts.

# MAIN COMPONENT POWER TRANSMISSION (SD MODELS)

ITEM NO.	PART NO.	DESCRIPTION	NO. REQ'D	ITEM NO.	PART NO.	DESCRIPTION	NO. REQ'D
<b>Clutch Lever Assembly</b>				44	5268	Bearing W/Collar (3/4)	2
1	8358	Clutch Lever (Includes Items # 2 & 3)	1	45	7241-2	Transmission Drive Pulley (3-1/4/MV) (Includes Items # F067 & F171)	1
2	5830	Grease Fitting	7				
3	7860	Handle Grip	1	46	7833	Cable Clamp (7/8 x 1/4)	1
4	7303-10	Clutch Actuator Bolt (3/8)	1	47	7394-6	Idler Pulley Spring Mount	1 <sup>Δ</sup>
5	7380-5	Knuckle Joint (3/8 ID)	1	48	8349	Transmission Belt Tightener Arm	1
6	7226-10	Compression Spring (3/4 x 2-1/2)	1	49	8393-7	Hydro Jackshaft Mount	1
7	8130-5	Push Rod, Clutch Actuator (Threaded Tube)	1		8394-1	Hydro Jackshaft Mount Assembly (Includes Items # 2, 9, 41, 44, 49 & 50)	*
8	8130-10	Clutch Actuator Rod Assembly (Includes Items # 2, 4-7, F054, F336 & F353)	1	50	8273	Jackshaft (3/4 x 7-1/2)	1
9	7201-3	DU Bearing	6	51	7240-3	Jackshaft Drive Pulley (Includes Items # F067 & F171)	1
10	7201-5	Inner Race (2-1/4)	1	52	7240-4	Jackshaft Drive Pulley (3.3/3V) (Includes Items # F067 & F171)	1**
11	8368	PTO Belt Tightener	1				
12	5841	Retainer Washer (3/8 x 1-1/4)	4	53	8349-3	Idler Arm, MTLEFI	1***
13	8243	Clutch Idler Pulley Assembly (Includes Items # 14, 15 & F070)	1	<b>Fasteners</b>			
	8243-1	Clutch Idler Pulley	1		F003	1/4-28 Hex Nut	2
14	5265	Bearing (3/4)	1		F004	1/4-20 Keps Nut	3
15	8243-3	Hub, Idler Pulley	1		F005	1/4-20 ESNA Nut	1
16	8375	PTO Belt Tightener Stop	1		F009	5/16-18 Whiz Locknut	3
17	7377	Plastic Washer (1 x .438 x .025)	2		F012	3/8-16 Keps Nut	8
18	7378	Pivot Bearing (7/16 x 9/16)	1		F029	1/4-20 x 1/2 Hex Bolt	1
19	5281-5	Clevis Pin (1/4 x 0.80)	2		F040	3/8-16 x 1-1/2 Hex Bolt	1
20	5280	Clevis (1/4)	2		F041	3/8-16 x 1-3/4 Hex Bolt	2
21	8305	Brake Actuator Rod	1		F042	3/8-16 x 2-1/4 Hex Bolt	3
22	8370	Bearing, Brake Actuator	1		F043	3/8-16 x 3 Hex Bolt	1
23	8250	Brake Spring (1/2 x 2-1/2)	1		F047	3/8-16 x 4-1/2 Hex Bolt	1
24	8369	Brake Actuator (Includes Items # 2 & 22)	1		F054	AN960616 Washer	3
<b>PTO Drive Shaft Assembly</b>					F061	1/4 Internal Star Lock Washer	1
25	7050-1	Dipstick, Gearbox	1		F067	3/16 x 3/16 x 1 Key	2
26	8371-1	Mount Bracket, Brake Band	1		F069	3/32 x 1/2 Cotter Pin	2
27	8377	Brake Band Guide	1		F070	1-3/4 Internal Snap Ring	1
28	8050-11	PTO Gearbox / Flange Pulley	1		F090	1/4-20 x 2-1/2 Hex Bolt	1
29	5245	Idler Pulley (3")	2		F116	1/4-20 x 1-1/4 Hex Bolt	1
30	7248	Ground Drive Belt, Micro-V	1		F121	5/16-18 x 3/8 x 1 SHL Bolt	1
31	7275-16	Universal Joint Tube Assembly/Spine	1		F131	5/16-18 x 1/2 Hex Bolt	2
32	7523-2	Clevis Pin (1/4 x 5/8)	1		F132	1/4-20 x 2-3/4 Hex Bolt	1
33	8304	Brake Band (14-1/2)	1		F168	5/16 Split Lock Washer	14
34	6250	Drive Belt (3VX375)	1		F171	5/16-18 x 3/8 Set Screw	4
35	7236-1	PTO Drive Pulley (4-1/2/3V) (Includes Items # F168 & F226)	1		F178	1/4 x 1 Fender Washer	1
36	8237-2	Engine Pulley, Bolt On (4/3.8/3V) (Includes Items # F168 & F226)	1		F182	5/8 x 1/4 x 1/8 Washer	2
37	8230	Engine PTO Belt	1		F186	5/64 x 1/2 Cotter Pin	1
<b>Jackshaft Assembly</b>					F226	5/16-18 x 7/8 Hex Bolt	14
38	7245-1	Idler Pulley (3/8 Groove)	1		F241	.375 x .875 x .10 Washer	1
39	6325-2	Spacer Bushing (5/16)	2		F255	5/16-18 x 1-1/2 Hex Bolt	2
40	8349-2	Idler Arm	1		F261	AN960616L Washer	1
41	7201-4	Inner Race (1-1/2)	2		F336	3/8-16 Jam Nut	1
42	5221	Extension Spring (3/4 x 4)	2		F353	3/8-16 ESNA LP Nut	1
43	8539	Starter Relay Mount	1				
				*	Service Part Only		
				**	Item used on MTL and MTLEFI only		
				***	Item used on MTLEFI only		
				Δ	Item used on MT only		

Use only genuine **Walker**<sup>®</sup> replacement parts.

Effective Date 09-15-05



# MAIN COMPONENT POWER TRANSMISSION (SD MODELS)

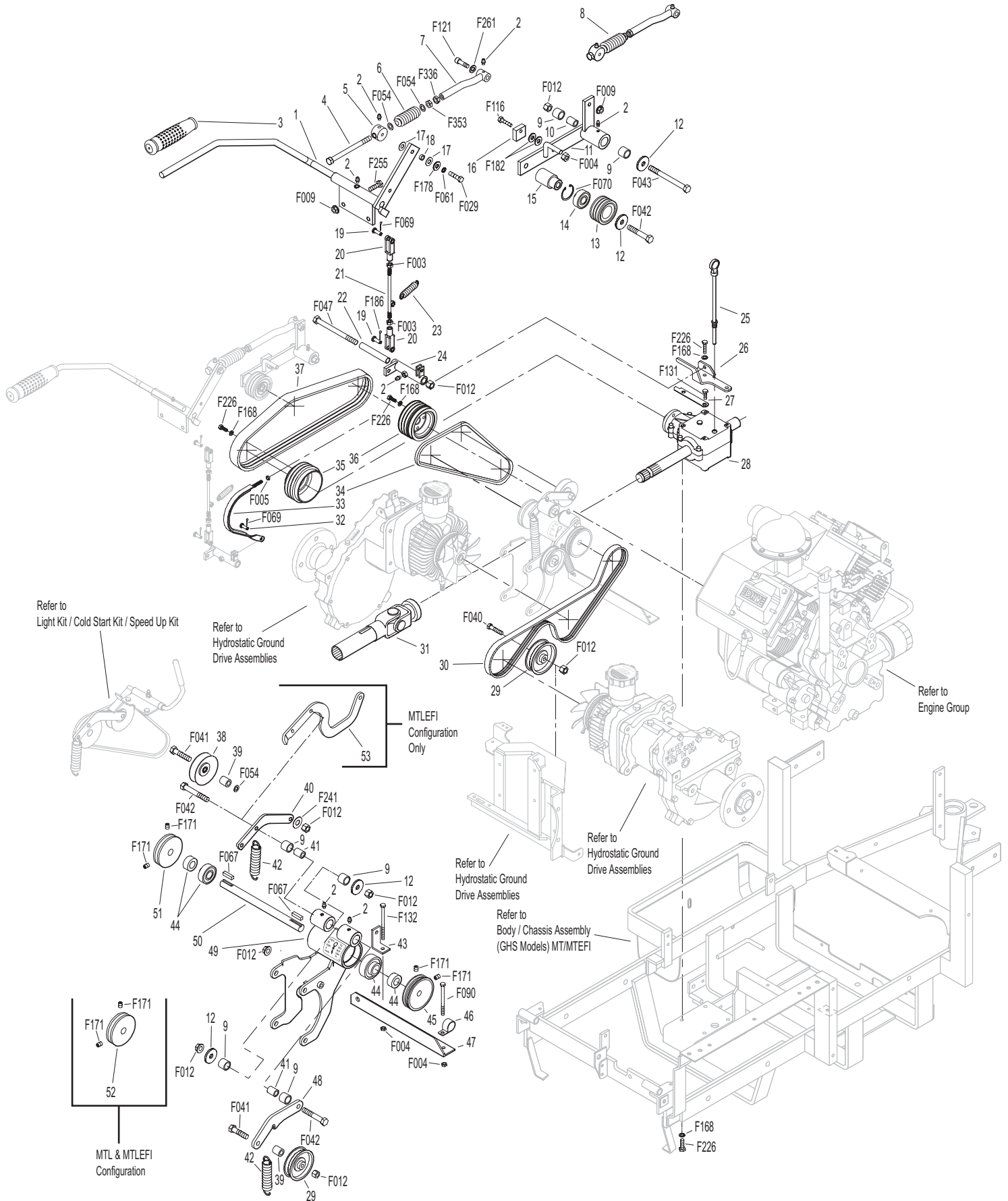

Effective Date 09-15-05

Use only genuine Walker® replacement parts.

# ENGINE GROUP (MT)

ITEM NO.	PART NO.	DESCRIPTION	NO. REQ'D	ITEM NO.	PART NO.	DESCRIPTION	NO. REQ'D	
<b>Precleaner Assembly</b>				<b>Exhaust Assembly</b>				
1	7026-2	Remote Precleaner (Includes Item # 5)	1	38	8530-8	Muffler Grass Shield (Includes Items # F002 & F025)	1	
2	7440	Shock Mount (1.0 OD x .75)	3	39	NS	Screw (Kohler M-645016-S)	2	
3	7028-20	Rear Precleaner Mount	1	40	NS	Gasket (Kohler)	2	
4	7027	Elbow, Precleaner	1	41	NS	Nut (Kohler)	4	
5	7840	Hose Clamp (1-5/16 to 2-1/4)	4	42	8013-9	Muffler	1	
6	5088-12	Air Cleaner Assembly (Includes Items # 8-12 & 14)	*	43	8013-13	Muffler Heat Shield	1	
7	5088-1	Air Cleaner Band	1	44	8013-18	Muffler Brace	1	
8	5090-3	Safety Filter	1	45	8021	Engine Brace	1	
9	5090-1	Air Cleaner Cartridge	1	46	8013-29	Muffler Heat Shield Endcap	1	
10	5088-5	Air Cleaner Draw Latch	2	47	8013-61	Muffler Heat Deflector W/Knurled Inserts	1	
11	5088-11	Air Cleaner Cap (Includes Item # 10)	1	<b>Fasteners</b>				
12	5090-2	Vacuator Valve	1		F002	10-24 Keps Nut	2	
13	8026-10	Air Hose, Cleaner	1		F004	1/4-20 Keps Nut	4	
14	5091-11	Air Flow Indicator & Nipple	1		F009	5/16-18 Whiz Locknut	13	
15	7031	Tube Support Arm	1		F012	3/8-16 Keps Nut	1	
16	7028-3	Precleaner Tube, SD	1		F025	10-24 x 3/8 PPHMS	2	
17	7028-2	Precleaner Tube, GHS	1		F026	10-24 x 1/2 PPHMS	3	
18	6029	Hose Clamp (2-1/2)	1		F029	1/4-20 x 1/2 Hex Bolt	4	
<b>Engine Assembly</b>						F031	1/4-20 x 5/8 Hex Bolt	1
19	NS	20-hp Engine	1		F035	5/16-18 x 1-1/4 Hex Bolt	2	
20	NS	Fuel Pump (Kohler)	1		F038	3/8-16 x 1 Hex Bolt	2	
21	5879-3	Hose Clamp (1/2)	4		F050	1/4 SAE Washer	1	
22	NS	Fuel Line, Engine (Kohler)	*		F052	5/16 External Star Lock Washer	2	
23	5020	Fuel Filter	*		F053	7/16 Int. Star Lock Washer	2	
24	NS	Oil Filter (Kohler 1205001)	1		F061	1/4 Internal Star Lock Washer	4	
25	8010-6	Valve Cover Sleeve	2		F063	3/8 Internal Star Lock Washer	2	
26	5845	Bumper, Rubber (1.50 OD x 1.25)	1		F079	A/A66D Aluminum Pop Rivet	2	
27	8010-2	Engine Bumper Mount	1		F090	1/4-20 x 2-1/2 Hex Bolt	2	
28	5832	Cable Clamp (1/2)	3		F091	5/16-18 x 5/8 Hex Bolt	2	
<b>Fuel Tank Assembly</b>						F106	3/8-16 x 5/8 Hex Bolt	2
29	8015-3	Fuel Line, Tank (1/4 x 24-1/2)	1		F120	AN960416 Washer	2	
30	5083-1	Bushing, Rubber	*		F129	10-24 x 1/2 PTHMS	1	
31	5086	Fuel Line (In Tank P/U)	1		F140	7/16-14 x 1 Hex Bolt	2	
32	8023	Fuel Tank Support	1		F175	1/2 Split Lock Washer	4	
33	5020-1	Fuel Filter, In Tank	1		F256	7/16 SAE Washer	2	
34	8046-9	Fuel Tank, 5 Gallon, Gas (Includes Items # 35 & 36)	1		F273	M6 x 1.0 Nut	4	
35	5082-2	Fuel Cap Seal	*		F274	M6 x 1.0 45 Stud	2	
36	5082	Fuel Tank Cap (Includes Item # 35)	*		F285	1/2-13 x 1-1/2 Hex Bolt	4	
37	5083-2	Tank Tube Elbow	1		F324	M8 x 1.25 x 12 Hex Bolt	2	

\* Service Part Only

**NOTE:** Item 16 is used only on SD Models. Item 17 is used only on GHS Models. Both items use existing fasteners at clutch lever.

**NOTE:** Refer to Kohler Engine Decal (NS) for Engine Identification Numbers.

# ENGINE GROUP (MT)

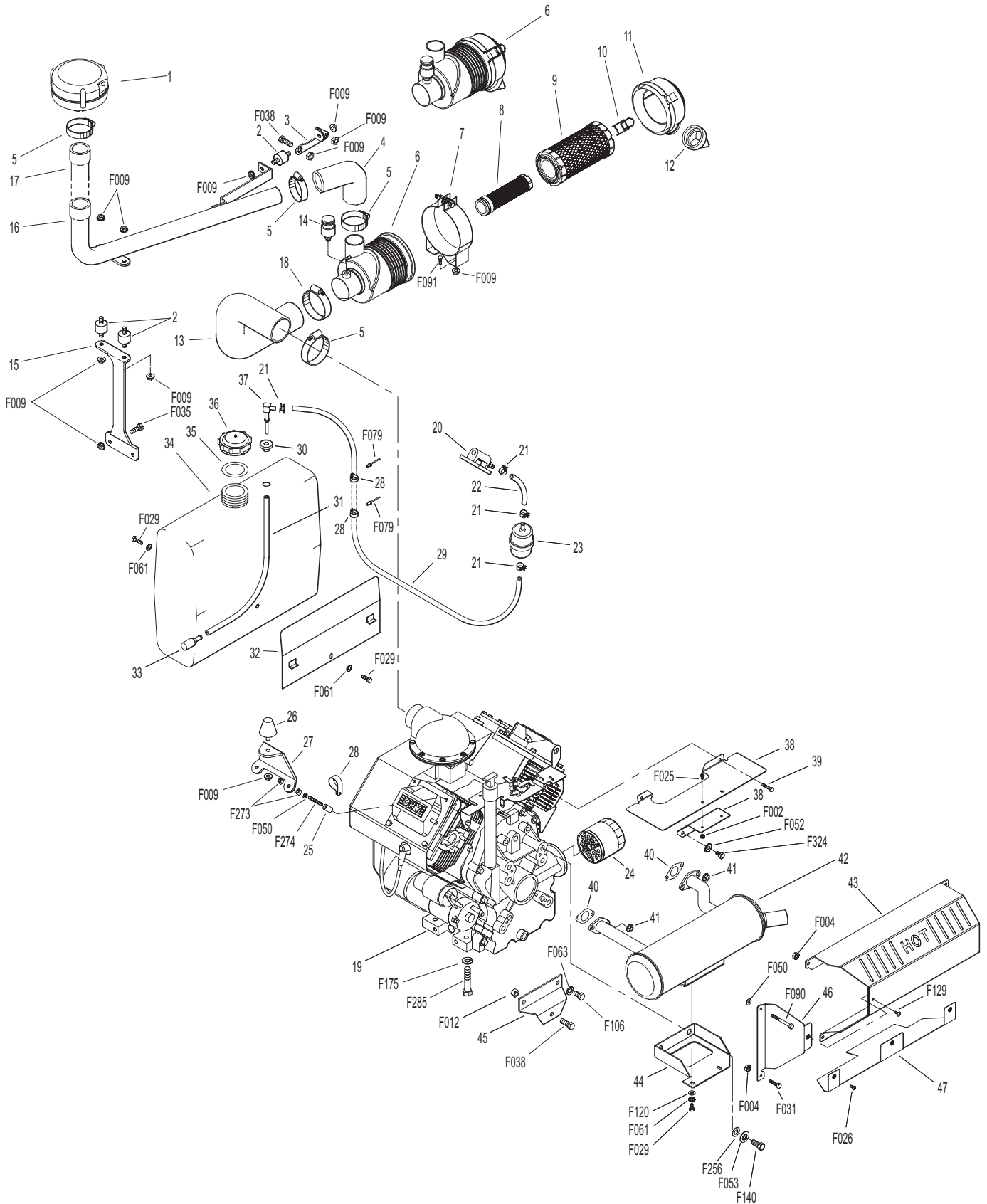

Effective Date 09-15-05

Use only genuine Walker® replacement parts.

# ENGINE GROUP (MTL)

ITEM NO.	PART NO.	DESCRIPTION	NO. REQ'D	ITEM NO.	PART NO.	DESCRIPTION	NO. REQ'D
<b>Fuel Tank Assembly</b>				<b>Engine Assembly</b>			
1	5083-2	Tank Tube Elbow	1	23	NS	Oil Filter (Kohler 1205001)	1
2	5879-3	Hose Clamp (1/2)	4	24	7958-2	Resistor Mount Plate	1
3	8015-3	Hose (1/4 x 24-1/2)	1	25	NS	Regulator (Kohler)	1
4	NS	Fuel Pump (Kohler)	1	26	8012-3	Regulator Mount	1
5	NS	Fuel Line (Kohler)	1	27	NS	25-hp Engine	1
6	5020	Fuel Filter	*	28	7306-12	Temperature Sender Adapter	1
7	5832	Cable Clamp (1/2) (Uses Existing Fasteners at Engine)	2	29	7306-15	Water Temperature Sender	1
8	5083-1	Bushing, Rubber	*	<b>Fasteners</b>			
9	5086	Fuel Line (In Tank P/U)	1	F002	10-24 Keps Nut		2
10	5020-1	Fuel Filter, In Tank	1	F009	5/16-18 Whiz Locknut		2
11	8046-9	Fuel Tank, 5 Gallon, Gas (Includes Items # 12 & 13)	1	F012	3/8-16 Keps Nut		2
12	5082-2	Fuel Cap Seal	*	F025	10-24 x 3/8 PPHMS		2
13	5082	Fuel Tank Cap (Includes Item # 12)	*	F029	1/4-20 x 1/2 Hex Bolt		1
<b>Exhaust Assembly</b>				F038	3/8-16 x 1 Hex Bolt		1
14	5665	Compression Spring (1/2 x 1)	2	F041	3/8-16 x 1-3/4 Hex Bolt		4
15	8530-15	Muffler End Shield	1	F050	1/4 SAE Washer		4
16	8530-17	Upper Grass Shield	2	F051	3/8 SAE Washer		4
17	8013-34	Muffler Mount Tab	1	F061	1/4 Internal Star Lock Washer		1
18	8013-31	Muffler	1	F063	3/8 Internal Star Lock Washer		3
19	8013-32	Exhaust Pipe, Muffler	1	F079	A/A66D Aluminum Pop Rivet		2
20	8013-16	Mounting Spring, Muffler	2	F091	5/16-18 x 5/8 Hex Bolt		2
21	NS	Nut (Kohler)	4	F106	3/8-16 x 5/8 Hex Bolt		2
22	NS	Gasket (Kohler)	2	F187	1/4-20 x 1-1/2 Hex Bolt		4
				F188	1/4-20 Self-Locking Nut		4
				F243	M6 Split Lock Washer		4
				F273	M6 x 1.0 Nut		2
				F328	M6 x 1.0 x 16 Hex Bolt		4

\* Service Part Only

**NOTE:** Refer to Kohler Engine Decal (NS) for Engine Identification Numbers.

# ENGINE GROUP (MTL)

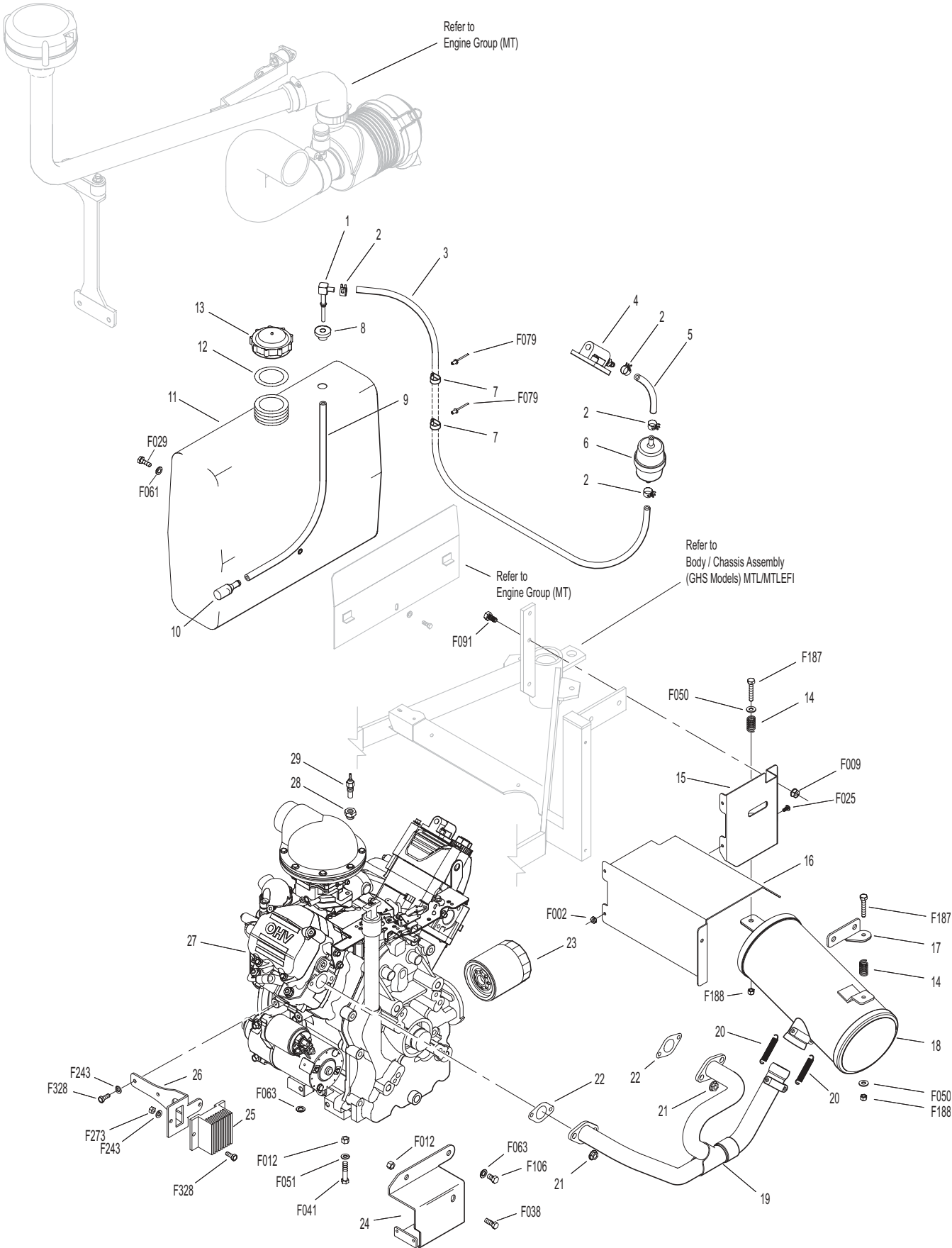

# ENGINE GROUP (MTEFI)

ITEM NO.	PART NO.	DESCRIPTION	NO. REQ'D	ITEM NO.	PART NO.	DESCRIPTION	NO. REQ'D
<b>Fuel Tank Assembly</b>				<b>Exhaust Assembly</b>			
1	5083-2	Tank Tube Elbow	1	28	8530-9	Grass Shield, Muffler (EFI) (Includes Items # F002 & F025)	1
2	5879-5	Stepless Ear Clamp (5/8)	7	29	NS	Screw (Kohler M645016-S)	1
3	8026-3	Fuel Line (5/16 x 32) Tank to Pump (Includes Item # 2)	1	30	NS	Sensor, Oxygen (Kohler)	1
4	7833	Cable Clamp (7/8 x 1/4)	4	31	NS	Gasket (Kohler)	2
5	8026-5	Fuel Line (5/16 x 21) Regulator to Filter (Includes Item # 2)	1	32	NS	Nut (Kohler M-0841080)	4
6	8026-14	Clamp, Loop Style	1	33	8013-11	Muffler (EFI)	1
7	5879-3	Hose Clamp (1/2)	2	34	8013-13	Muffler Heat Shield	1
8	NS	Fuel Regulator (Kohler)	1	35	8013-18	Muffler Brace	1
9	NS	Fuel Filter (Kohler)	1	36	8021	Engine Brace	1
10	8026-4	Fuel Line (5/16 x 8) Pump to Regulator (Includes Item # 2)	1	37	8013-29	Muffler Heat Shield Endcap	1
11	8026-6	Fuel Line (5/16 x 13") Filter to Engine (Includes Item # 2)	1	38	8013-61	Muffler Heat Deflector W/Knurled Inserts	1
12	NS	Fuel Pump (Kohler)	1	<b>Fasteners</b>			
13	NS	Clamp (Kohler)	2	F002	10-24 Keps Nut	5	
14	7014-3	Fuel Pump Mount Plate	1	F004	1/4-20 Keps Nut	6	
15	8026-8	Vent Tube	1	F012	3/8-16 Keps Nut	1	
16	7014-2	Regulator/Filter Mount	1	F025	10-24 x 3/8 PPHMS	4	
17	5832	Cable Clamp (1/2) (Uses Existing Fasteners at Engine)	3	F026	10-24 x 1/2 PPHMS	3	
18	5083-1	Bushing, Rubber	*	F027	10-24 x 5/8 PPHMS	3	
19	7046-1	Fuel Return Tube	1	F029	1/4-20 x 1/2 Hex Bolt	3	
20	8026-7	Hose (1/4 x 16)	1	F031	1/4-20 x 5/8 Hex Bolt	4	
21	5086	Fuel Line (In Tank P/U)	1	F038	3/8-16 x 1 Hex Bolt	1	
22	5020-1	Fuel Filter, In Tank	1	F050	1/4 SAE Washer	1	
23	5082	Fuel Tank Cap (Includes Item # 24)	*	F052	5/16 External Star Lock Washer	2	
24	5082-2	Fuel Cap Seal	*	F053	7/16 Int. Star Lock Washer	2	
25	8046-7	Fuel Tank, 5 Gallon, Gas (Includes Items # 18, 23 & 24)	1	F061	1/4 Internal Star Lock Washer	4	
<b>Engine Assembly</b>				F063	3/8 Internal Star Lock Washer	2	
26	NS	Oil Filter (Kohler 1205001)	1	F079	A/A66D Aluminum Pop Rivet	2	
27	NS	26-hp EFI Engine (78528)	1	F090	1/4-20 x 2-1/2 Hex Bolt	1	
				F106	3/8-16 x 5/8 Hex Bolt	2	
				F120	AN960416 Washer	2	
				F129	10-24 x 1/2 PTHMS	1	
				F140	7/16-14 x 1 Hex Bolt	2	
				F175	1/2 Split Lock Washer	4	
				F256	7/16 SAE Washer	2	
				F285	1/2-13 x 1-1/2 Hex Bolt	4	
				F324	M8 x 1.25 x 12 Hex Bolt	2	

\* Service Part Only

**NOTE:** Refer to Kohler Engine Decal (NS) for Engine Identification Numbers.

# ENGINE GROUP (MTEFI)

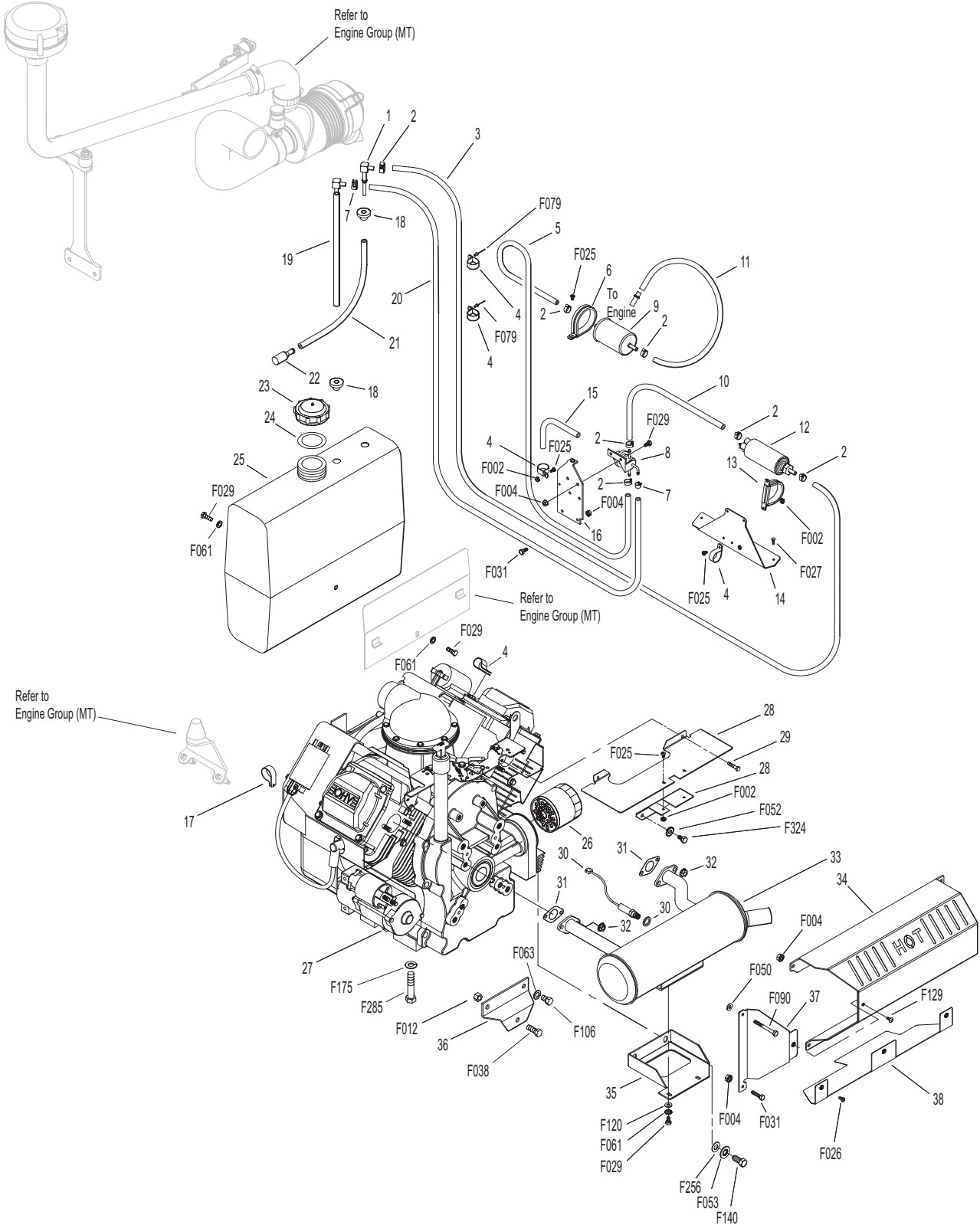

# ENGINE GROUP (MTLEFI)

ITEM NO.	PART NO.	DESCRIPTION	NO. REQ'D	ITEM NO.	PART NO.	DESCRIPTION	NO. REQ'D
<b>Fuel Tank Assembly</b>				<b>Engine Assembly</b>			
1	8026-7	Hose (1/4 x 16)	1	39	NS	Oil Filter (Kohler 1205001)	1
2	8026-5	HP Fuel Line (5/16 x 21) Regulator To Filter (Includes Item # 3)	1	40	7958-2	Resistor Mount Plate	1
3	5879-5	Stepless Ear Clamp (5/8)	7	41	NS	Regulator (Kohler)	1
4	8026-14	Clamp, Loop Style	1	42	8012-3	Regulator Mount	1
5	NS	Fuel Filter (Kohler)	1	43	8392	Coil Mount Plate, Front	1
6	8026-12	HP Fuel Line (5/16 x 26) Filter to Engine	1	44	8392-1	Coil Mount Plate, Rear	1
7	7014-7	Fuel Line Guard	1	45	NS	25-hp Engine	1
8	8026-11	HP Fuel Line (5/16 x 16) Pump To Regulator	1	46	7306-12	Temperature Sender Adapter	1
9	8026-8	Vent Tube, Regulator	1	47	7306-15	Water Temperature Sender	1
10	NS	Fuel Regulator (Kohler)	1	<b>Fasteners</b>			
11	5879-3	Hose Clamp (1/2)	2	F002	10-24 Keps Nut		4
12	7014-2	Regulator/Filter Mount	1	F004	1/4-20 Keps Nut		4
13	7833	Cable Clamp (7/8 x 1/4)	1	F009	5/16-18 Whiz Locknut		6
14	NS	Fuel Pump (Kohler)	1	F012	3/8-16 Keps Nut		5
15	NS	Clamp (Kohler)	2	F025	10-24 x 3/8 PPHMS		4
16	5832	Cable Clamp (1/2)	1	F026	10-24 x 1/2 PPHMS		2
17	7014-5	Fuel Pump Mount	1	F027	10-24 x 5/8 PPHMS		4
18	7014-6	Fuel Pump Cover	1	F029	1/4-20 x 1/2 Hex Bolt		2
19	8026-9	Hose (5/16 x 8) Tank to Pump	1	F031	1/4-20 x 5/8 Hex Bolt		2
20	5083-2	Tank Tube Elbow	1	F034	5/16-18 x 3/4 Hex Bolt		2
21	5083-4	Plug Bushing (Viton)	1	F038	3/8-16 x 1 Hex Bolt		1
22	5086-7	Fuel Line (3/8 x 6)	1	F041	3/8-16 x 1-3/4 Hex Bolt		4
23	5020-2	Fuel Filter, In Tank	1	F050	1/4 SAE Washer		2
24	8046-4	Fuel Tank, 5.0 Gallon, Gas, MTLEFI (Includes Items # 25, 26 & 27)	1	F051	3/8 SAE Washer		4
25	5082-2	Fuel Cap Seal	1	F061	1/4 Internal Star Lock Washer		2
26	5082	Fuel Tank Cap (Includes Item # 25)	1	F063	3/8 Internal Star Lock Washer		3
27	5083-1	Bushing, Rubber (Fits 5083)	1	F091	5/16-18 x 5/8 Hex Bolt		2
28	7046-1	Fuel Return Tube	1	F106	3/8-16 x 5/8 Hex Bolt		2
<b>Exhaust Assembly</b>				F187	1/4-20 x 1-1/2 Hex Bolt		2
29	5665	Compression Spring (1/2 x 1)	2	F188	1/4-20 Self-Locking Nut		2
30	8530-15	Muffler End Shield	1	F243	M6 Split Lock Washer		6
31	8530-17	Upper Grass Shield	1	F255	5/16-18 x 1-1/2 Hex Bolt		2
32	8013-34	Muffler Mount Tab	1	F273	M6 x 1.0 Nut		2
33	8013-31	Muffler	1	F328	M6 x 1.0 x 16 Hex Bolt		6
34	8013-16	Mounting Spring, Muffler	7	<b>* Service Part Only</b>			
35	8013-33	Exhaust Pipe	1	<b>NOTE:</b> Refer to Kohler Engine Decal (NS) for Engine Identification Numbers.			
36	NS	Nut (Kohler)	4				
37	NS	Gasket (Kohler)	2				
38	NS	Oxygen Sensor (Kohler)	1				

Use only genuine **Walker**<sup>®</sup> replacement parts.

Effective Date 09-15-05





## RADIATOR GROUP (MTL/MTLEFI)

ITEM NO.	PART NO.	DESCRIPTION	NO. REQ'D	ITEM NO.	PART NO.	DESCRIPTION	NO. REQ'D
<b>Radiator Assembly</b>				26	7840-4	Hose Clamp (3/4 to 1-1/2)	2
1	7429-9	Radiator Fan Shield (Includes Items # 21, 22 & F081)	1	27	7017-5	Upper Radiator Hose	1
2	7427-21	Fan Mount Tab, LH	2	28	7017-7	Radiator Hose Bracket	1
3	7429-6	Radiator Cooling Fan	1	29	8530-18	Fan Heat Shield	1
4	7432	Shock Mount (1.00 OD x .75) Radiator	3	30	8530-7	Exhaust Shield Mount, MTL	1
5	7427-6	Radiator Fan Shroud	1	<b>Fasteners</b>			
6	7427-30	Radiator, MTL	1	F002	10-24 Keps Nut		4
7	7431-1	Radiator Channel Seal (1/4 x 1/2 x 13.5)	2	F004	1/4-20 Keps Nut		10
8	7435	Radiator Brace	1	F014	3/8-16 ESNA Nut		1
9	7425	Radiator Screen	1	F025	10-24 x 3/8 PPHMS		3
10	7426	Screen Channel	2	F026	10-24 x 1/2 PPHMS		1
11	7434	Rubber Washer (3/8 x 1-1/4 x 1/4)	4	F029	1/4-20 x 1/2 Hex Bolt		6
12	7430	Radiator Guard	1	F031	1/4-20 x 5/8 Hex Bolt		4
13	5841	Retainer Washer (3/8 x 1-1/4)	2	F050	1/4 SAE Washer		1
14	7427-7	Debris Shield, Shroud	1	F053	7/16 Int. Star Lock Washer		2
15	7427-3	Coolant Recovery Tank	1	F061	1/4 Internal Star Lock Washer		6
16	7427-10	Recovery Tank Mount	1	F073	1/4 x 1.5 Fender Washer		1
17	7427-11	Recovery Tank Keeper	1	F081	A/A45D Aluminum Pop Rivet		1
18	7015-13	Recovery Tank Hose	1	F090	1/4-20 x 2-1/2 Hex Bolt		2
19	5975-3	Cable Tie (50# x 7")	3	F129	10-24 x 1/2 PTHMS		7
20	7427-22	Fan Mount Tab, RH	2	F140	7/16-14 x 1 Hex Bolt		2
21	8620-30	Backing Plate	1	F360	1/4-20 x 3/8 Hex Bolt		1
22	5161-10	Rubber Flap	1	<b>NOTE:</b> Decals for this assembly are not shown here. Refer to <b>TRACTOR DECALS</b> , Page 2 for Decal listing and placement information.			
23	7840-3	Hose Clamp (1/2 to 1-1/4)	2				
24	7017-4	Lower Radiator Hose	1				
25	7833-1	Single Eyelet Clamp	1				

# RADIATOR GROUP (MTL/MTLEFI)

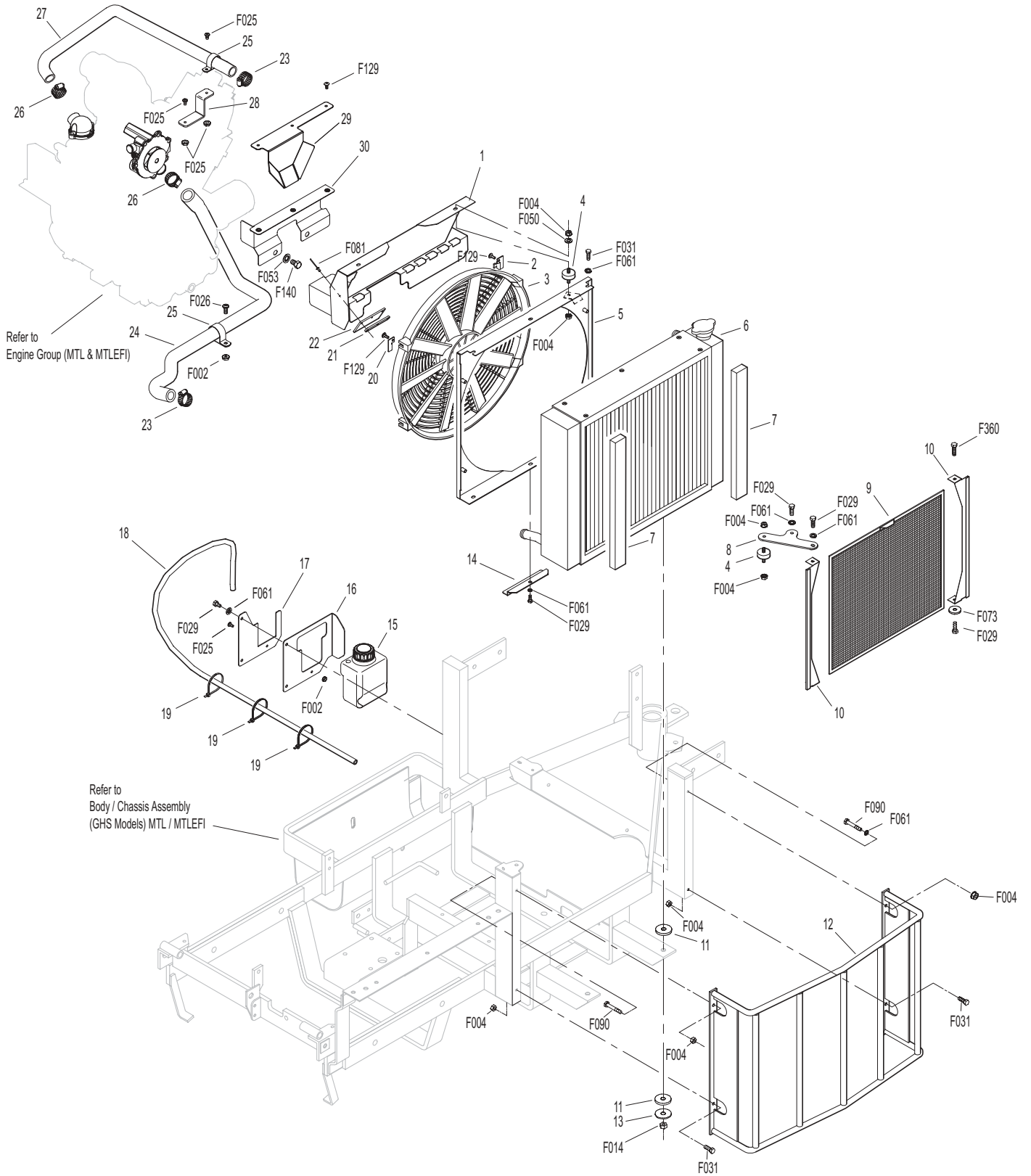

# HYDROSTATIC GROUND DRIVE ASSEMBLIES

ITEM NO.	PART NO.	DESCRIPTION	NO. REQ'D	ITEM NO.	PART NO.	DESCRIPTION	NO. REQ'D
<b>Transmission Lockout Assembly</b>				<b>Transmission Repair Parts</b>			
1	5028-3	Transmission Lockout Assembly (Includes Items # 2-5, F023, F027 & F081)	*	26	5025-5	Input Shaft	*
2	5847	Plastic Tip	2	27	5025-8	Bearing, Input Shaft	*
3	5057	Lockout Cam (Includes Item # F081)	2	28	5025-7	Snap Ring	*
4	5028-5	Lockout Lever	2	29	5025-2	Seal, Input Shaft	*
5	5027-5	Lockout Mount	1**	30	5022	Reservoir to Casting Gasket	*
<b>Ground Drive Assemblies</b>				31	5024	Reservoir Cap and Gasket	*
6	6209-1	Bridge Assembly	1	32	5023	Transmission Reservoir Kit	*
7	6243-2	Hydro Fan, CCW	1	33	5023-1	Rubber Bladder	*
8	5026	Hydrostatic Drive, CW (700-041)	1	34	5025-6	O-Ring & Plug Assembly	*
9	6206-1	Air Vent Valve	*	35	5025-3	Seal, Control Shaft	*
10	6200-9	Gear Axle Drive Assembly (Includes Items # 9 & 11)	2	<b>Fasteners</b>			
11	6207-12	Pipe Plug (1/4 NPTF)	4	F012	3/8-16 Keps Nut		2
12	5126	Cable Retainer (Uses existing bolt on Gear Axle Drive Assembly)	1	F023	10-24 ESNA Nut		2
13	6233-1	Pinion Gear	2	F027	10-24 x 5/8 PPHMS		2
14	6234	Spacer, Pinion Gear	2	F036	1/4-20 x 1/2 SBH Screw		2
15	6201	O-Ring Seal	2	F038	3/8-16 x 1 Hex Bolt		4
16	7244	Hydro Pulley (3-7/8) (Includes Items # F064 & F359)	2	F040	3/8-16 x 1-1/2 Hex Bolt		4
17	6243-1	Hydro Fan, CW	1	F043	3/8-16 x 3 Hex Bolt		6
18	5025	Hydrostatic Drive, CCW (700-042)	1	F051	3/8 SAE Washer		2
<b>Deck Support Arm Assemblies</b>				F053	7/16 Internal Star Lock Washer		4
19	6430-10	Outboard Mount, LH	1	F063	3/8 Internal Star Lock Washer		14
20	6430-2	Deck Support Arm, LH (Includes Item # 24)	1	F064	1/8 x 1/2 Woodruff Key (#3)		4
21	5775-2	Hitch Pin (# 6)	2	F081	A/A45D Aluminum Pop Rivet		2
22	6430-1	Deck Support Arm, RH (Includes Item # 24)	1	F160	External Snap Ring (.669 Shaft)		2
23	6430-9	Outboard Mount, RH	1	F178	1/4 x 1 Fender Washer		2
24	5830	Grease Fitting	2	F194	7/16 x 1-1/4 x 1/8 Washer		2
25	6840-1	Support Arm Bushing (2-1/16)	2	F200	7/16-20 x 3 Grade 8 Bolt		2
				F244	7/16-20 x 3/4 Hex Bolt		2
				F355	3/8-16 x 4 Hex Bolt		1
				F359	5/16-18 x 5/16 Set Screw (Unbrako Knurl Point)		4
				F416	3/8-16 x 4 Soc Hd Cap Screw		1
				* Service Part Only			
				** Part not used on Jackshaft side of tractor.			

# HYDROSTATIC GROUND DRIVE ASSEMBLIES

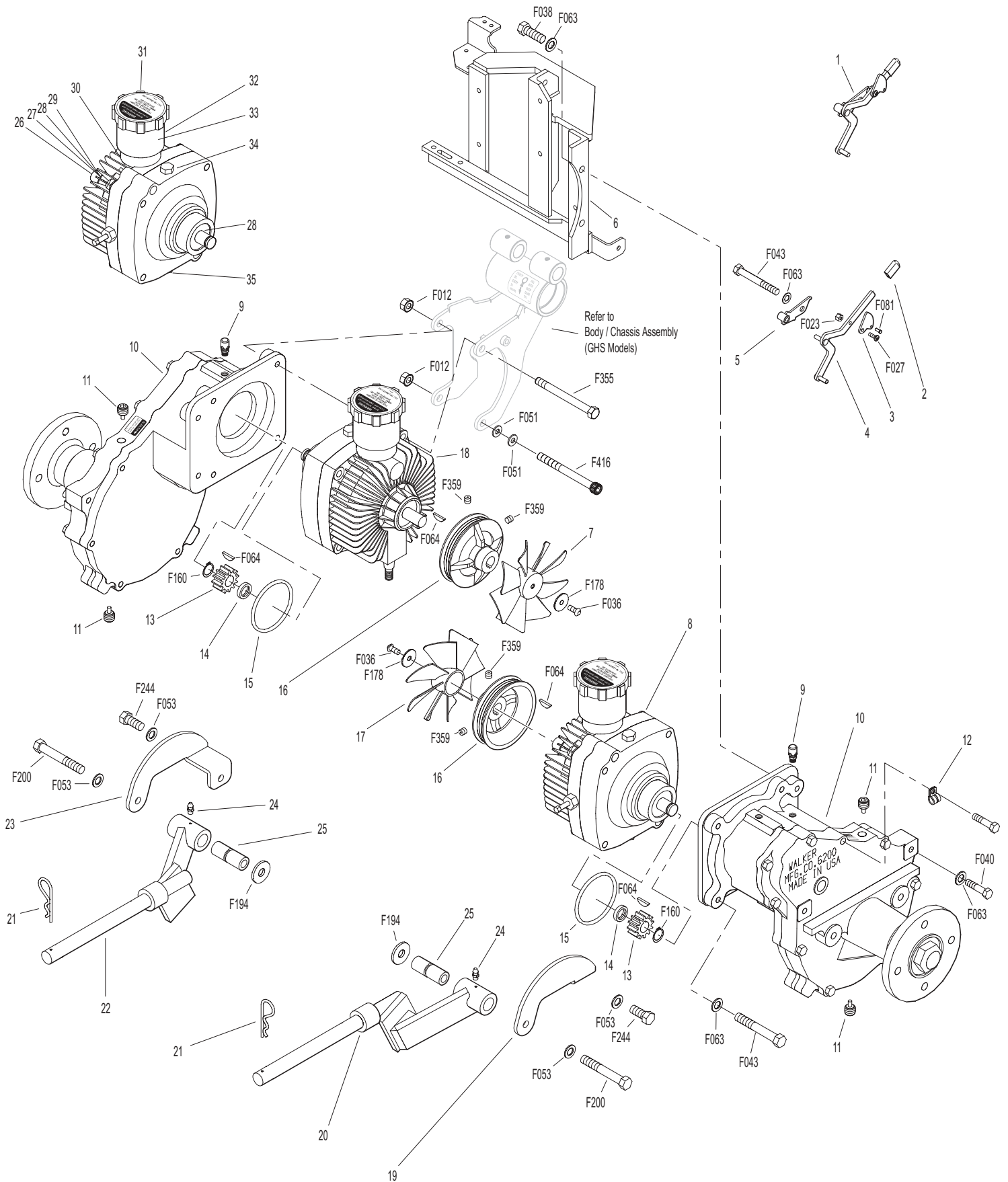

Effective Date 09-15-05

Use only genuine Walker® replacement parts.

# STEERING CONTROL ASSEMBLIES

ITEM NO.	PART NO.	DESCRIPTION	NO. REQ'D	ITEM NO.	PART NO.	DESCRIPTION	NO. REQ'D
<b>Transmission Spring Assemblies</b>				35	5450-3	Steering Lever Assembly, RH / Adjustable (Includes Items # 16, 21, 36, F188, F198 & F345)	1
1	6199	Transmission Spring Assembly (RH) (Includes Items # 2-8, F003, F287, F320 & F352)	*		5450-5	Steering Lever Arm, RH / Adjustable	*
2	5552	Ball Joint (1/4-28)	2		5450-6	Steering Lever Assy RH / Adjustable / MTL	*
3	5192-1	Spring Plunger (5/32)	2	36	5453-10	Steering Lever Handle, Adjustable (Includes Items # 21 & F345)	2
4	5194	Plunger Sleeve	2				
5	5193	Washer (3/4 x 1 x .085)	2	37	5862	FSC Knob	1
6	6191	Spring Slide (4-3/4)	1	38	7170	FSC Lever Assembly (Includes Item # 16)	1
7	5195	Compression Spring (1 x 5-1/8)	2				
8	6196	Spring Slide Cap	1	39	5975-3	Cable Tie (50# x 7")	1
9	5197	J-Bolt	1	40	5213-1	Control Rod, RH (15")	1
10	5191	Spring Slide (3-5/8)	1	41	6201-2	Shock Mount Gear Drive/RH	1**
11	5199	Transmission Spring Assembly (LH) (Includes Items # 2-5, 7, 9, 10, F003, F146, F287 & F352)	*	42	5146	10mm Ball Stud	4**
<b>Steering Lever &amp; FSC Assemblies</b>				43	4215-2	Steering Lever Dampener	2**
12	5214-2	Ball Joint (5/16-24) Nylon Lined	2	44	5450-4	Steering Lever Arm RH / Adjustable / MTL	1**
13	5173	FSC Actuator Rod	1	45	5451-4	Steering Lever Arm LH / Adjustable / MTL	1**
14	5172	Bearing, Nylon (.255 ID x .379 OD x .250)	1	46	6201-1	Shock Mount Gear Drive/LH	1**
15	5142-2	FSC Actuator Cam	1	<b>Fasteners</b>			
16	5830	Grease Fitting	6	F003	1/4-28 Hex Nut		3
17	6212	Transmission Control Arm, RH	1	F004	1/4-20 Keps Nut		8
18	5141	FSC Friction Washer (1-1/2 x 3/8 x 1/16)	2	F007	5/16-18 Jam Nut		1
19	5140-15	FSC Friction Body (Includes Item # 16)	1	F008	5/16-24 Keps Nut		2
20	5142-7	FSC Key W/Stop	1	F009	5/16-18 Whiz Locknut		5
	5140-13	FSC Control Assembly (Includes Items # 16, 18-20, F192 & F193)	*	F010	5/16-24 ESNA Nut		2
21	5850-2	Handle Grip, Foam (5-1/2)	2	F012	3/8-16 Keps Nut		2
22	5212-2	Transmission Control Arm, LH	1	F024	5/16-24 Jam Nut		2
23	5213-2	Control Rod, LH (6")	1	F029	1/4-20 x 1/2 Hex Bolt		2
24	5223	Extension Spring (1/4 x 5-1/2)	2	F032	1/4-20 x 3/4 Hex Bolt		4
25	5450	D-Clip	2	F034	5/16-18 x 3/4 Hex Bolt		1
26	5463	Steering Lever Actuator	2	F050	1/4 SAE Washer		3
27	5214-1	Bearing (.320 x .438 x .250)	2	F051	3/8 SAE Washer		2
28	5391-3	Steering Lever Support	1	F064	1/8 x 1/2 Woodruff Key (#3)		2
29	5217	Pivot Pin, Steering Lever	1	F068	1/8 x 1 Cotter Pin		1
30	5451-3	Steering Lever Assembly, LH / Adjustable (Includes Items # 16, 21, 36, F188, F198 & F345)	1	F069	3/32 x 1/2 Cotter Pin		1
	5451-5	Steering Lever Arm, LH / Adjustable	*	F093	5/16-18 x 1 Hex Bolt		1
	5451-6	Steering Lever Assy, LH / Adjustable / MTL	*	F146	1/4-20 Jam Nut		1
31	5219	Extension Spring (3/4 x 6-3/4)	1	F182	1/4 x 5/8 x 1/8 Washer		2
32	5280	Clevis (1/4)	1	F183	.312 x .700 x .074 Washer		2
33	5281-5	Clevis Pin (1/4 x 0.80)	1	F186	5/64 x 1/2 Cotter Pin		1
34	5470-1	Speed Control Stop	1	F188	1/4-20 Self-Locking Nut		4
				F192	3/8-24 Self-Locking Nut		1
				F193	3/8 Belleville Spring Washer		3
				F198	.250 x .625 x .040 Washer, SS		2
				F287	1/4-28 Keps Nut		2
				F320	1/8 x 3/4 Split Spring Pin		1
				F345	1/4-20 x .770 Knurled Bolt		4
				F352	5/32 x 1 Heavy Duty Roll Pin		2
				F401	.504 x .751 x .030 Washer		1

\* Service Part Only

\*\* All parts for Steering Dampener MTL & MTLEFI only.

Use only genuine **Walker**<sup>®</sup> replacement parts.

Effective Date 09-15-05

# STEERING CONTROL ASSEMBLIES

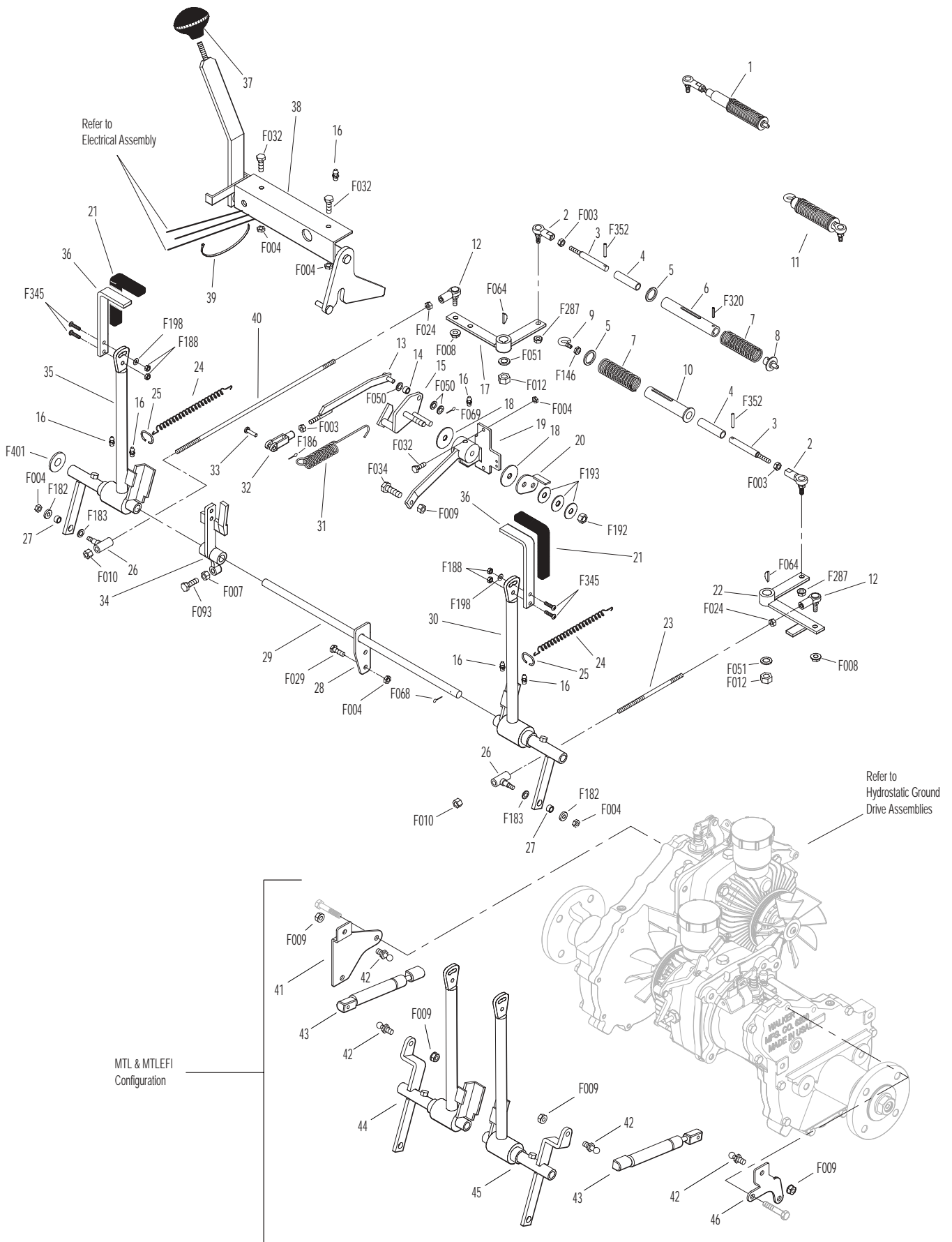

Effective Date 09-15-05

Use only genuine Walker® replacement parts.

# THROTTLE & CHOKE CONTROL ASSEMBLY

ITEM NO.	PART NO.	DESCRIPTION	NO. REQ'D	ITEM NO.	PART NO.	DESCRIPTION	NO. REQ'D
<b>Throttle &amp; Choke Control Assemblies</b>				<b>Fasteners</b>			
1	8121-1	Throttle Cable	1		F004	1/4-20 Keps Nut	4
2	8122-1	Choke Cable	1		F005	1/4-20 ESNA Nut	2
3	5172	Bearing, Nylon (.255 x .379 x .250)	2		F029	1/4-20 x 1/2 Hex Bolt	2
4	5108-7	Control Lock Tab	2		F050	1/4 SAE Washer	1
5	5108-10	Friction Washer (.125)	2		F164	10-24 x 1/4 x 3/8 SHL Bolt	1
6	5108-1	Control Lever, Throttle & Choke	2		F201	1/4 Belleville Spring Washer	4
7	5108-5	Throttle Control Knob, Red	1				
8	5108-11	Friction Washer (.062)	2	*	Service Part Only		
9	5108-8	Control Bracket	2				
10	7108	Control Assembly (Includes Items # 4-6, 8, 9 & F201)	2	Δ	Model MTEFI and MTLEFI do not use choke.		
	8121	Throttle Control and Cable Assembly (Includes Item # 7)	*				
	8122	Choke Control and Cable Assembly (Includes Item # 11)	*Δ				
11	5108-6	Choke Control Knob, Black	1				
12	8123	Insulation Sleeve (3/8 x 6)	1				
13	5975-1	Cable Tie (18# x 3-3/4")	1				



# THROTTLE & CHOKE CONTROL ASSEMBLY

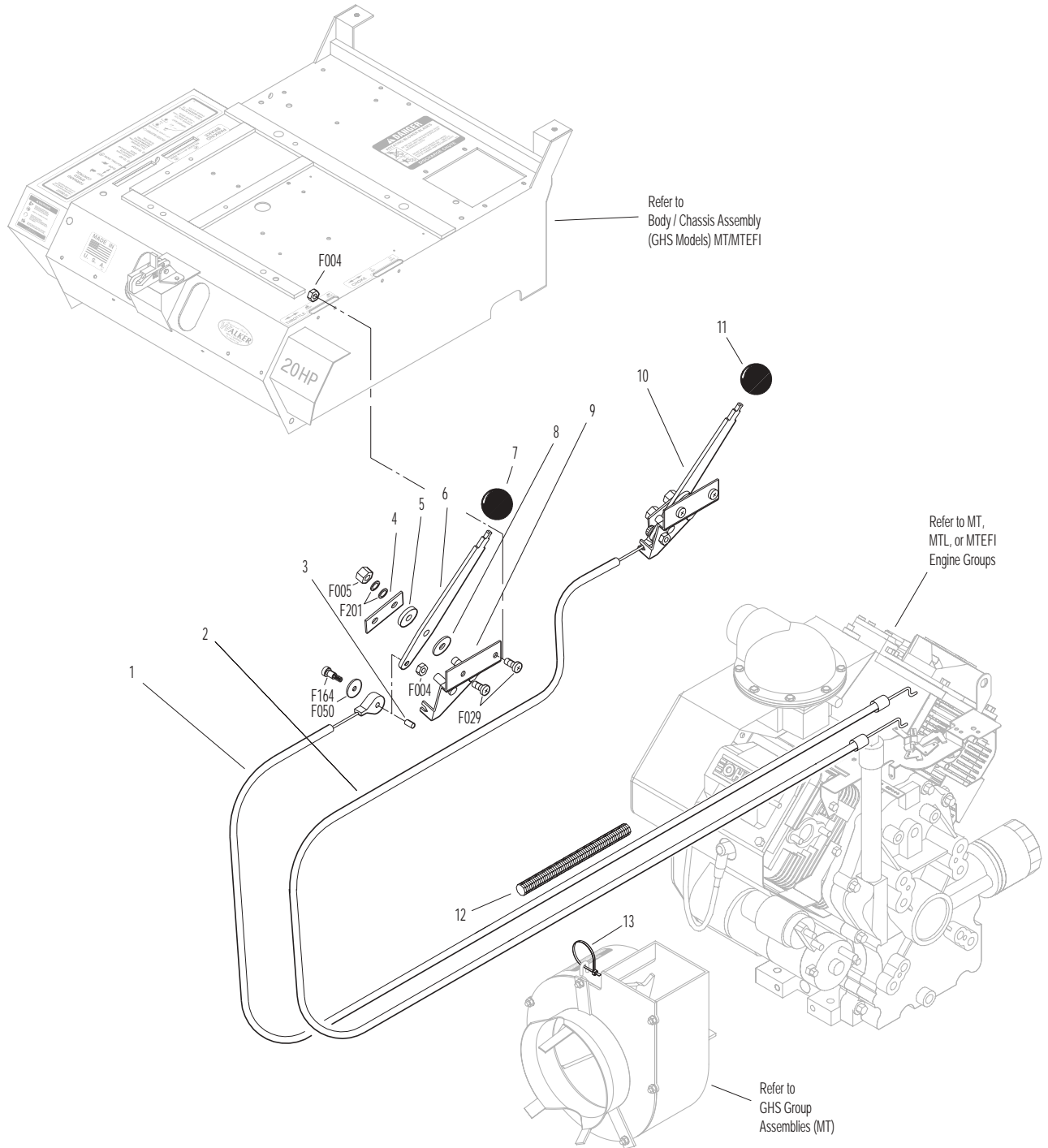

# PARKING BRAKE ASSEMBLY

ITEM NO.	PART NO.	DESCRIPTION	NO. REQ'D	ITEM NO.	PART NO.	DESCRIPTION	NO. REQ'D
<b>Parking Brake Assembly</b>				<b>Fasteners</b>			
1	7406-1	Handle Grip, Red	1	F003		1/4-28 Hex Nut	1
2	7406-8	Parking Brake Lever (4-1/4)	1	F004		1/4-20 Keps Nut	6
3	7406-2	Lever Mount	1	F029		1/4-20 x 1/2 Hex Bolt	5
4	5830	Grease Fitting	1	F032		1/4-20 x 3/4 Hex Bolt	1
5	7407	Clevis Pin (3/16 x 1/2)	2	F054		AN960616 Washer	2
6	7404	Brake Actuator Arm	2	F072		1/4 "E" Retainer Ring	2
7	7405	Pin, Transmission Lock	2	F086		#10 SAE Washer	4
8	7402	Clevis	2	F109		1/8 x 5/8 Roll Pin	2
9	7408	Compression Spring (1/2 x 3/4)	2	F111		1/8 x 3/4 Cotter Pin	1
10	7415	Rubber Dust Shield (5/8 x 3/8 x 1/32)	2	F112		5/8 x 1-1/4 x .03 Washer	2
11	5567-3	O-Ring Seal (1/4 x 3/8)	4	F127		1/16 x 1/2 Cotter Pin	4
12	7403	Plunger Bushing, Gear Axle	2	F261		AN960616L Washer	5
13	7404-1	Brake Actuator Mount	2	F287		1/4-28 Keps Nut	1
14	7412	Clevis Pin (3/16 x 5/8)	2				
15	5833	Cable Clamp (1/4)	2				
16	7410	Brake Control Cable, LH (27")	1				
17	7409	Brake Control Cable, RH (21")	1				
18	7401-3	Cable Mount Bracket	1				
19	7401-1	Cable Pull Rod	1				
20	5552	Ball Joint (1/4-28)	1				

# PARKING BRAKE ASSEMBLY

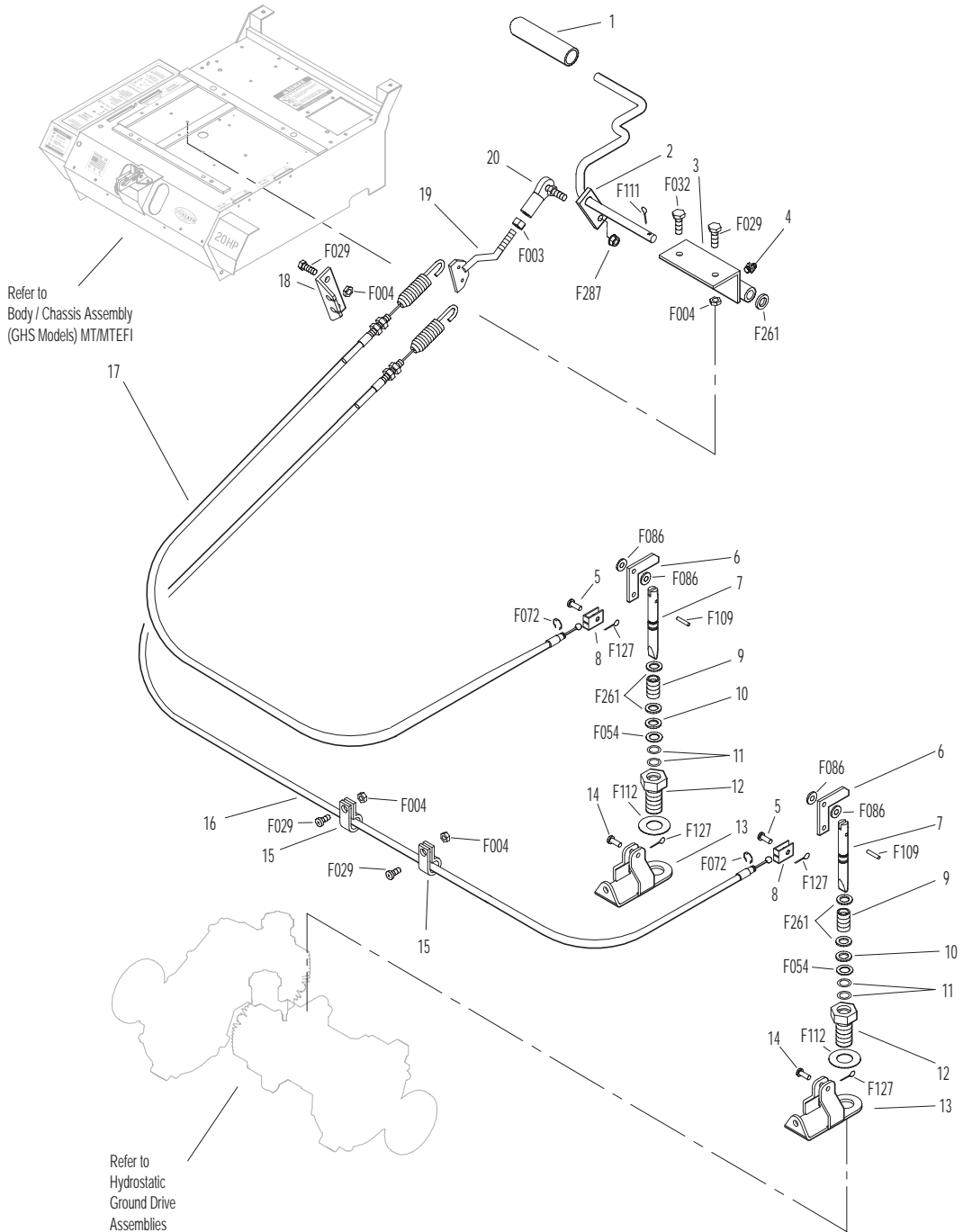

# GHS GROUP (MT)

ITEM NO.	PART NO.	DESCRIPTION	NO. REQ'D	ITEM NO.	PART NO.	DESCRIPTION	NO. REQ'D
<b>Delivery Chute Assembly</b>				<b>Fasteners</b>			
When Optional 9.5 Bushel Catcher Assembly is purchased, Item # 6 is replaced by P/N 8511-1 (Delivery Chute Assembly, 9.5).							
1	5515-2	Elbow Delivery Spout	1	F002		10-24 Keps Nut	8
2	5592-13	Backing Plate, Grass-Pak® Switch	1	F004		1/4-20 Keps Nut	6
3	5592-12	Mount Plate, Grass-Pak® Switch	1	F009		5/16-18 Whiz Locknut	1
4	5578	Rear Clip, Chute Mount	1	F012		3/8-16 Keps Nut	3
5	5577	Side Clip, Chute Mount	2	F025		10-24 x 3/8 PPHMS	2
6	7511-1	Delivery Chute W/Clips / 7.0 (Includes Items # 4, 5, 7, F362 & F411)	1	F026		10-24 x 1/4 PPHMS	2
	8511-1	Delivery Chute W/Clips / 9.5 (Includes Items # 4, 5, 7, F362 & F411)		F034		5/16-18 x 3/4 Hex Bolt	1
7	5578-10	Front Clip, Chute Mount	1	F038		3/8-16 x 1 Hex Bolt	1
8	7530-3	Body Chute	1	F040		3/8-16 x 1-1/2 Hex Bolt	1
<b>Blower Belt Tightener Assembly</b>							
9	7238-1	Blower Drive Pulley (Mirco-V) (Includes Items # F075, F114 & F231)	1	F042		3/8-16 x 2-1/4 Hex Bolt	1
10	7234-1	Blower Belt (Micro-V)	1	F054		AN960616 Washer	1
11	7239-1	Blower Pulley (Mirco-V) (Includes Items # F067, F075 & F114)	1	F067		3/16 x 3/16 x 1 Key	1
12	7364-2	Torsion Spring	1	F074		1/4-20 x 3/8 Set Screw	2
13	7201-3	DU Bearing	2	F075		5/16-18 x 1/2 SQH Set Screw	2
14	5830-3	Grease Fitting (45 Deg.)	1	F079		A/A66D Aluminum Pop Rivet	6
15	7364-1	Blower Belt Tightener Arm	1	F102		10-24 x 1-1/2 PTHMS	2
16	7201-4	Inner Race (1-1/2)	1	F114		5/16-18 x 5/8 SQH Set Screw	2
17	5841	Retainer Washer (3/8 x 1-1/4)	1	F128		10-24 x 3/8 PTHMS	4
18	5245	Idler Pulley (3")	1	F217		7/16-14 Hex Nut	1
<b>Blower Assembly</b>							
19	5268	Bearing W/Collar (3/4)	2	F218		7/16 Split Lock Washer	1
20	6543	Housing (10" Blower)	1	F219		7/16-14 x 1-1/4 Hex Bolt	1
	6542	Blower Assembly (10") (Includes Items # 19, 21-23 & F004)	*	F231		1/4 x 3/4 Woodruff Key (# 806)	1
21	6545	Blower Wheel (10")	1	F362		A/A62D Alum. Pop Rivet (3/16D x 13/32L)	2
22	6525-2	Faceplate (10" Blower)	1	F411		3/16 Bulbex Rivet	6
23	6526	Intake Tube (6-1/2 x 2-1/2)	1				
24	5595-2	Intake Cover/GHS	**				
25	7528	Skid Bar (10" Blower)	1				
26	7833	Cable Clamp (7/8 x 1/4)	1				

\* Service Part Only

\*\* Plugs Blower when GHS is not in use. Furnished only with Mulching Decks, SD Decks used on a GHS Tractor, Rotary Broom Attachment and Snowblower Attachment. Use of this part may be replaced by installing Blower Lockout Kit (P/N 6541). See Page 74.

# GHS GROUP (MT)

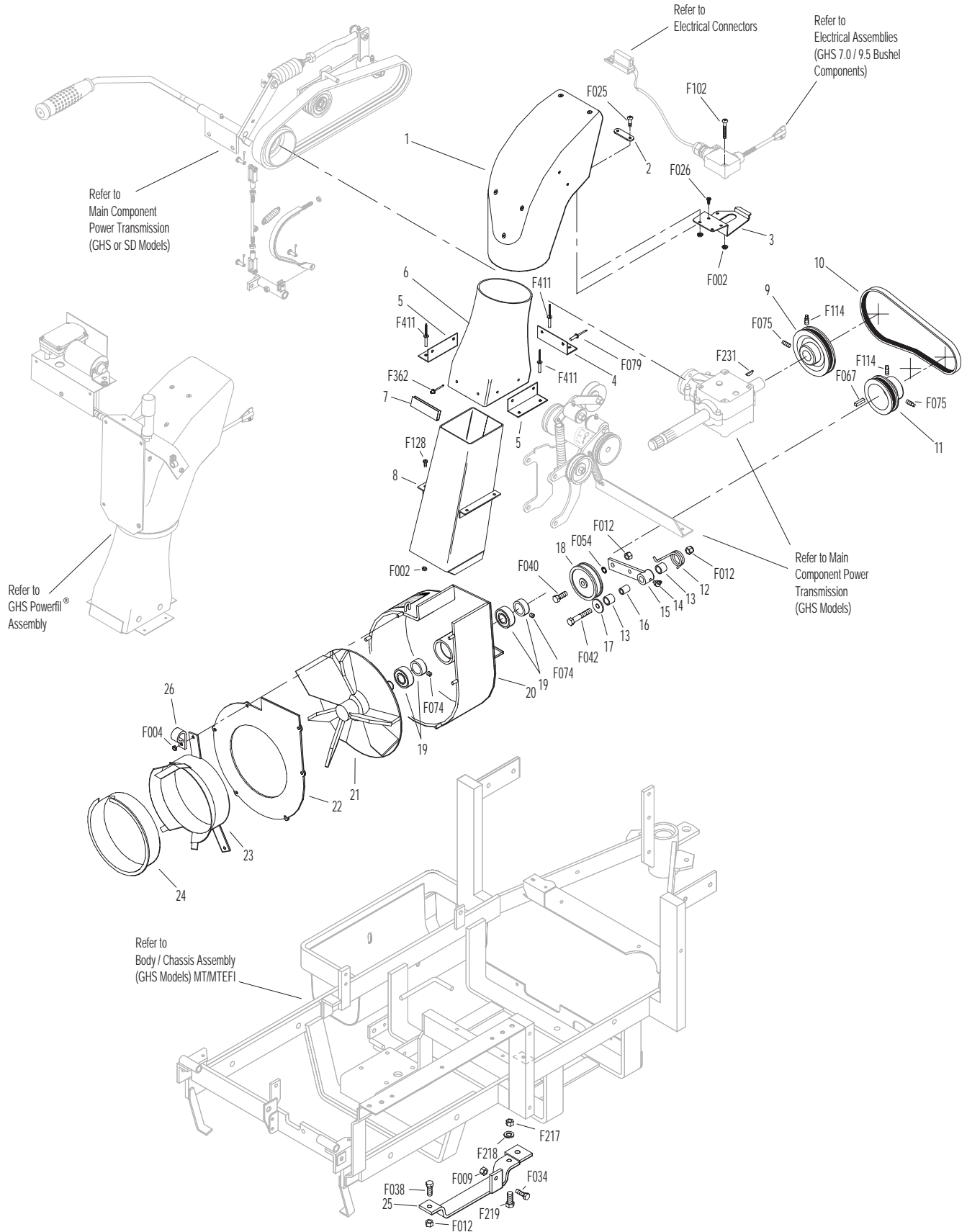

## 10.5" GHS BLOWER GROUP (MTL / MTEFI / MTLEFI)

ITEM NO.	PART NO.	DESCRIPTION	NO. REQ'D	ITEM NO.	PART NO.	DESCRIPTION	NO. REQ'D
<b>Blower Assembly</b>				<b>Fasteners</b>			
1	7542	Blower Assembly (10.5") (Includes Items # 4-11, F004, F050, F246 & F414)	1	F004		1/4-20 Keps Nut	9
2	7530-4	Body Chute (10.5 Blower)	1	F009		5/16-18 Whiz Locknut	1
3	7238-6	Blower Drive Pulley (Includes Items # F075, F114 & F231)	1	F012		3/8-16 Keps Nut	1
4	7239-1	Blower Pulley (Micro-V) (Includes Items # F067, F075 & F114)	1	F029		1/4-20 x 1/2 Hex Bolt	3
5	5268	Bearing W/Collar (3/4)	2	F034		5/16-18 x 3/4 Hex Bolt	1
6	7542-2	Back Plate (10.5 Blower)	1	F038		3/8-16 x 1 Hex Bolt	1
7	7545-2	Blower Output Shaft	1	F050		1/4 SAE Washer	1
8	7545	Blower Wheel (10.5")	1	F067		3/16 x 3/16 x 1 Key	1
9	7542-4	Scroll (10.5 Blower)	1	F075		5/16-18 x 1/2 SQH Set Screw	2
10	7542-3	Faceplate (10.5 Blower)	1	F090		1/4-20 x 2-1/2 Hex Bolt	1
11	7526	Intake Tube (10.5 Blower)	1	F114		5/16-18 x 5/8 SQH Set Screw	2
12	5595-2	Intake Cover/GHS	1	F131		5/16-18 x 1/2 Hex Bolt	3
13	7528-2	Skid Bar (10.5" Blower)	1	F132		1/4-20 x 2-3/4 Hex Bolt	1
				F168		5/16 Split Lock Washer	3
				F217		7/16-14 Hex Nut	1
				F218		7/16 Split Lock Washer	1
				F231		1/4 x 3/4 Woodruff Key, #806	1
				F246		1/4-20 x 1/2 PTHMS	1
				F281		7/16-14 x 1-3/4 Hex Bolt	1
				F414		1/4-20 x 5-1/8	5
				F415		1/4-20 x 6-1/8	1

# 10.5" GHS BLOWER GROUP (MTL / MTEFI / MTLEFI)

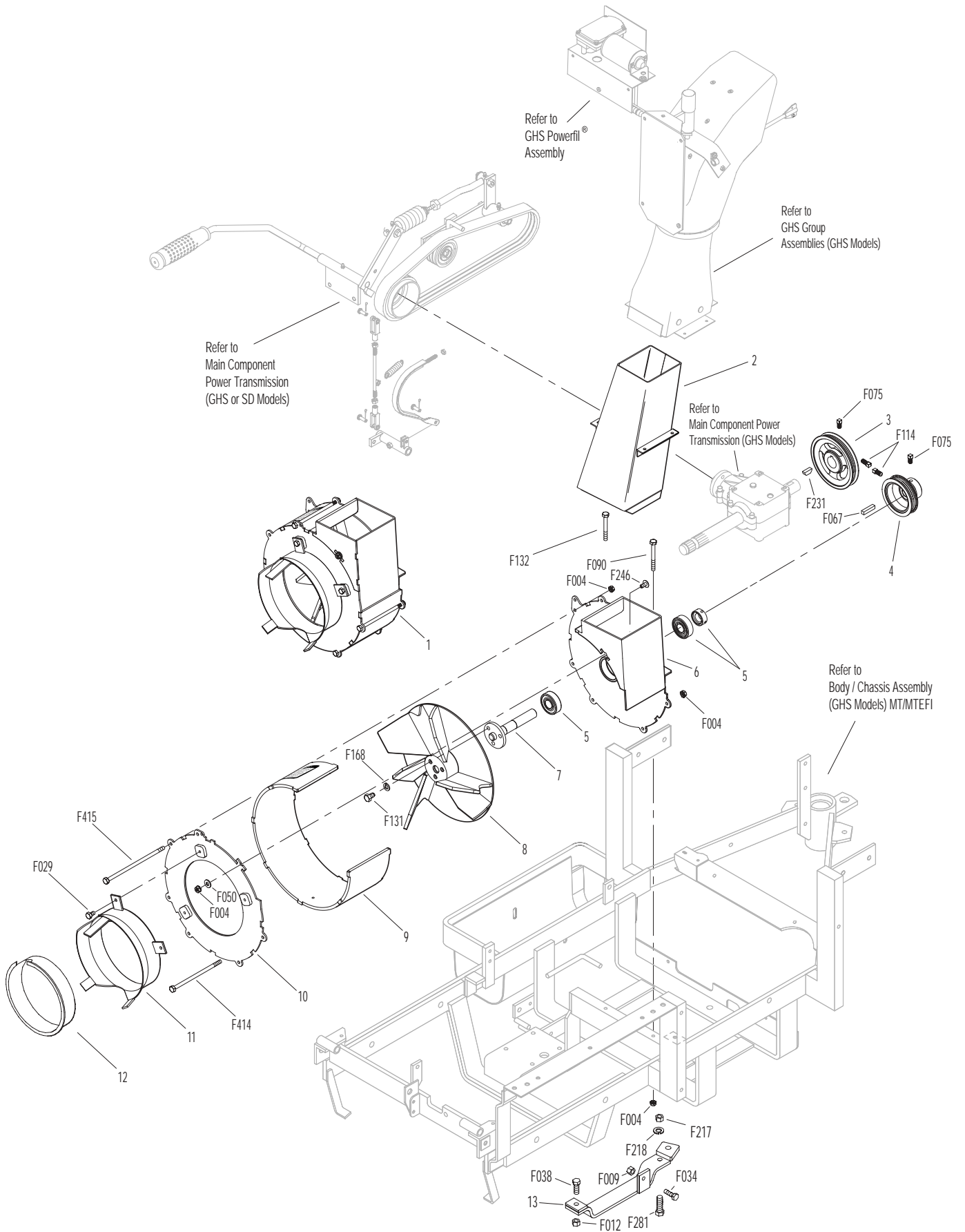

Effective Date 09-15-05

Use only genuine Walker<sup>®</sup> replacement parts.

# GHS POWERFIL® ASSEMBLY

ITEM NO.	PART NO.	DESCRIPTION	NO. REQ'D	ITEM NO.	PART NO.	DESCRIPTION	NO. REQ'D
<b>GHS Powerfil® Assembly</b>				<b>Fasteners</b>			
1	5557	Motor Mount, Powerfil®	1	F002		10-24 Keps Nut	10
2	5551-3	Bearing Cap, Powerfil®	1	F003		1/4-28 Hex Nut	3
3	5551-1	Pivot Bearing (#S3PP)	2	F025		10-24 x 3/8 PPHMS	4
4	5552	Ball Joint (1/4-28)	2	F054		AN960616 Washer	1
5	5518-2	Pivot, Delivery Spout	1	F085		#10 SAE Washer	1
6	5517-2	Pivot Mount	1	F101		10-24 x 1-1/4 SHC Screw	1
7	5558-1	Powerfil® Push Rod	1	F109		1/8 x 5/8 Roll Pin	1
8	5553-3	Bushing, Powerfil® Actuator	4	F129		10-24 x 1/2 PTHMS	4
9	5558-2	Powerfil® Actuator Rod	1	F261		AN960616L Washer	1
	5549	Actuator Rod Assembly (Includes Items # 4, 7-10 & F003)	*	F287		1/4-28 Keps Nut	1
10	5553-1	Compression Spring (1/2 x 2)	2	* Service Part Only			
11	5554	Actuator Arm	1				
12	5519-3	Motor Mount Nut (5/8-24)	*				
13	5519-2	Motor Mount Washer	*				
14	5519	Actuator Motor (12/24V) (Includes Items # 12 & 13)	1				
15	5977	Grommet (1/2 x 7/8 x 1/16)	1				

Use only genuine **Walker®** replacement parts.

Effective Date 09-15-05



# GHS POWERFIL® ASSEMBLY

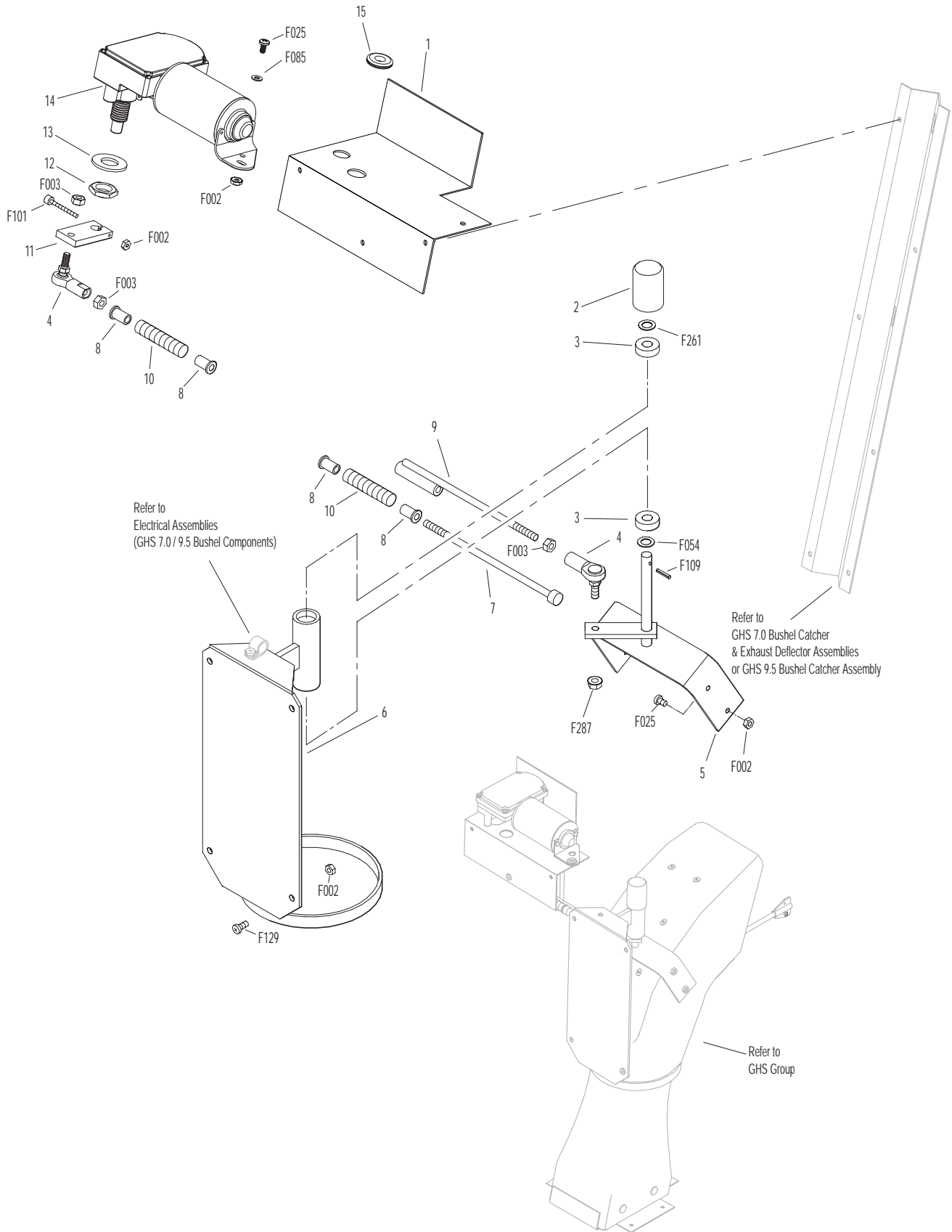

# GHS 7.0 BUSHEL CATCHER & EXHAUST DEFLECTOR ASSEMBLIES

ITEM NO.	PART NO.	DESCRIPTION	NO. REQ'D	ITEM NO.	PART NO.	DESCRIPTION	NO. REQ'D
<b>Upper Baffle Screen Assembly (Removable)</b>				34	7557-10	7.0 Wire Harness Channel	1
1	7509-3	Channel Bottom	2	35	5976	Grommet (3/8 x 11/16)	1
2	7505	Mustache Spring	2	36	5976-2	Grommet (3/16 x 3/4)	1
3	7507	Screen Seal (27-1/2)	1	37	5522-2	Hinge Backup Plate, RH	1
4	7856-1	Edge Molding (26")	1	38	7508	Safety Latch	1
5	7509-2	Channel Top	2	39	7584	Reinforcing Strap	2
6	7512-2	Removable Screen (3/16 Holes) (Includes Items # 7, F025 & F190)	1**	40	7514-1	Backup Plate	1
7	7506	Knob (10-24) Threaded Insert	2	<b>5598 Optional Dump Bag (Not Shown)</b>			
8	7509-4	C-Channel	1	May be ordered as an option. Contact your Walker dealer. Not used with Power Dump Option.			
<b>Exhaust Deflector Assembly</b>				<b>Fasteners</b>			
9	7504-3	Hinge (27")	1	F002		10-24 Keps Nut	29
10	7504-1	Exhaust Deflector (Two Piece Set)	1	F004		1/4-20 Keps Nut	13
	7504	Exhaust Deflector Kit	*	F009		5/16-18 Whiz Locknut	2
11	7504-8	Deflector Mount Doubler	2	F020		5/16-18 ESNA Nut	2
<b>GHS 7.0 Bushel Catcher Assembly</b>				F025		10-24 x 3/8 PPHMS	4
12	5583	Handle	1	F026		10-24 x 1/2 PPHMS	4
13	5588	Rubber Bumper (.75 x .50)	2	F027		10-24 x 5/8 PPHMS	4
14	7522	Side Strap, Door (7.0)	2	F035		5/16-18 x 1-1/4 Hex Bolt	1
15	7610	Catcher Dump Plate	1	F037		10-24 x 5/8 PTH Screw	2
16	7610-1	Dump Plate Slide	2	F049		5/16 SAE Washer	4
17	7513-2	7.0 Mounting Frame Doubler	1	F069		3/32 x 1/2 Cotter Pin	2
18	5281-5	Clevis Pin (1/4 x 0.80)	2	F079		A/A66D Aluminum Pop Rivet	20
19	7503	Mounting Frame (7.0) (Includes Item # 21)	1	F085		3/16 Rivet Backup Washer	15
20	5522-1	Hinge Backup Plate, LH	1	F129		10-24 x 1/2 PTHMS	8
21	7503-9	Pivot Bushing (5/16 x 5/8)	2	F137		3/8-16 x 1/2 x 2 SHL Bolt	2
22	7510-1	7.0 Bushel Catcher, Including Door	1	F172		1/4-20 x 3/4 Carriage Bolt	2
	7502-1	7.0 Catcher, Without Powerfil® (Includes Door & Deflector)	*	F188		1/4-20 Self Locking Nut	11
	7502-2	7.0 Catcher (With Powerfil®) (Includes Door & Deflector)	*	F190		#10 Internal Star Lock Washer	2
23	7514-10	7.0 Door Frame, Catcher	1	F195		1/4-20 x 3/4 PPHMS SS	14
24	5155-12	5/16 Ball Stud	2	F196		1/4-20 x 1 PPHMS SS	4
25	5147	Spring Clip	4	F198		.625 x .250 x .040 Washer, SS	8
26	5155-2	Gas Spring Cover	2	F228		# 6 x 1/2 PPHSM Set Screw	2
27	5155	Gas Spring Assembly / Catcher Door (Includes Items # 24, 25, 29 & F049)	2	F230		1/4-20 x 1-1/4 PPHMS SS	1
28	5524-1	Flanged Hinge Bearing	2	F242		1/4-20 x 7/8 PPHMS SS	9
29	5155-13	3/4 Ball Stud	2	F252		10-24 x 3/4 PPHMS	1
30	5523-6	Gas Spring Plate	2	F255		5/16-18 x 1-1/2 Hex Bolt	1
31	7532	Handle, Catcher Lift	2	F329		.260 ID x 1.939 OD Washer	2
	7534	Catcher Handle Kit (Includes Items # 31, 32, F004 & F172)	*	F330		3/16 D x 21/32 Rivet, SS	2
32	7533	Backing Plate, Handle	2	F340		Rivet, Aluminum	4
33	5155-15	Box Support, Gas Spring	2	F351		Aluminum Pop Rivet	3
				* Service Part Only			
				** This screen can be replaced by P/N 7512-3 Removable Screen (3/4" hole) for improved air flow performance in wet conditions.			

Use only genuine **Walker®** replacement parts.

Effective Date 09-15-05



# GHS 9.5 BUSHEL CATCHER ASSEMBLY

ITEM NO.	PART NO.	DESCRIPTION	NO. REQ'D	ITEM NO.	PART NO.	DESCRIPTION	NO. REQ'D
<b>GHS 9.5 Bushel Catcher Assembly</b>				<b>Fasteners</b>			
May be ordered as a factory-installed option. Contact your Walker dealer.							
1	8514-11	9.5 Door Frame	1	F002		10-24 Keps Nut	14
2	8510-1	9.5 Bushel Catcher, Including Door	1	F004		1/4-20 Keps Nut	16
	8502-1	9.5 Catcher Without Powerfil® (Includes Door & Deflector)	*	F009		5/16-18 Whiz Locknut	2
	8502-2	9.5 Catcher With Powerfil® (Includes Door & Deflector)	*	F020		5/16-18 ESNA Nut	2
3	7514-1	Backup Plate	1	F026		10-24 x 1/2 PPHMS	4
4	5588	Rubber Bumper (.75 x .50)	2	F027		10-24 x 5/8 PPHMS	4
5	8516	Side Strap, Door / 9.5	2	F035		5/16-18 x 1-1/4 Hex Bolt	1
6	5583	Handle	1	F037		10-24 x 5/8 PTH Screw	2
7	5522-1	Hinge Backup Plate, LH	1	F049		5/16 SAE Washer	4
8	7503-9	Pivot Bushing (5/16 x 5/8)	2	F069		3/32 x 1/2 Cotter Pin	1
9	8503	Mounting Frame (Includes Item # 8)	1	F079		A/A66D Aluminum Pop Rivet	11
10	5155-12	5/16 Ball Stud	2	F085		3/16 Rivet Backup Washer	9
11	5147	Spring Clip	4	F129		10-24 x 1/2 PTHMS	4
12	5155	Gas Spring Assembly / Catcher Door (Includes Items # 10, 11, 15 & F049)	2	F172		1/4-20 x 3/4 Carriage Bolt	2
13	5155-2	Gas Spring Cover	2	F188		1/4-20 Self Locking Nut	16
14	5524-1	Flanged Hinge Bearing	2	F195		1/4-20 x 3/4 PPHMS SS	7
15	5155-13	3/4 Ball Stud	2	F196		1/4-20 x 1 PPHMS SS	3
16	5523-6	Gas Spring Plate	2	F198		.625 x .250 x .040 Washer, SS	5
17	7533	Backing Plate, Handle	2	F230		1/4-20 x 1-1/4 PPHMS SS	1
18	7532	Handle, Catcher Lift	2	F242		1/4-20 x 7/8 PPHMS SS	23
19	5155-15	Box Support, Gas Spring	2	F252		10-24 x 3/4 PPHMS	1
20	8117	9.5 Wire Harness Channel	1	F255		5/16-18 x 1-1/2 Hex Bolt	1
21	5976	Grommet (3/8 x 11/16)	2	F329		.260 ID x 1.939 OD Washer	2
22	5522-2	Hinge Backup Plate, RH	1	F330		3/16 D x 21/32 L Rivet, SS	2
23	7508	Safety Latch Hinge	1	F351		Aluminum Pop Rivet	3
24	7584	Reinforcing Strap	2	* Service Part Only			
25	5281-5	Clevis Pin (1/4 x .080)	2	<b>NOTE:</b> Refer to <b>ELECTRICAL CONNECTORS</b> , Page 64 for identification of all Electrical Wiring Service Parts.			
26	8513-3	9.5 Mounting Frame Doubler	1				

# GHS 9.5 BUSHEL CATCHER ASSEMBLY

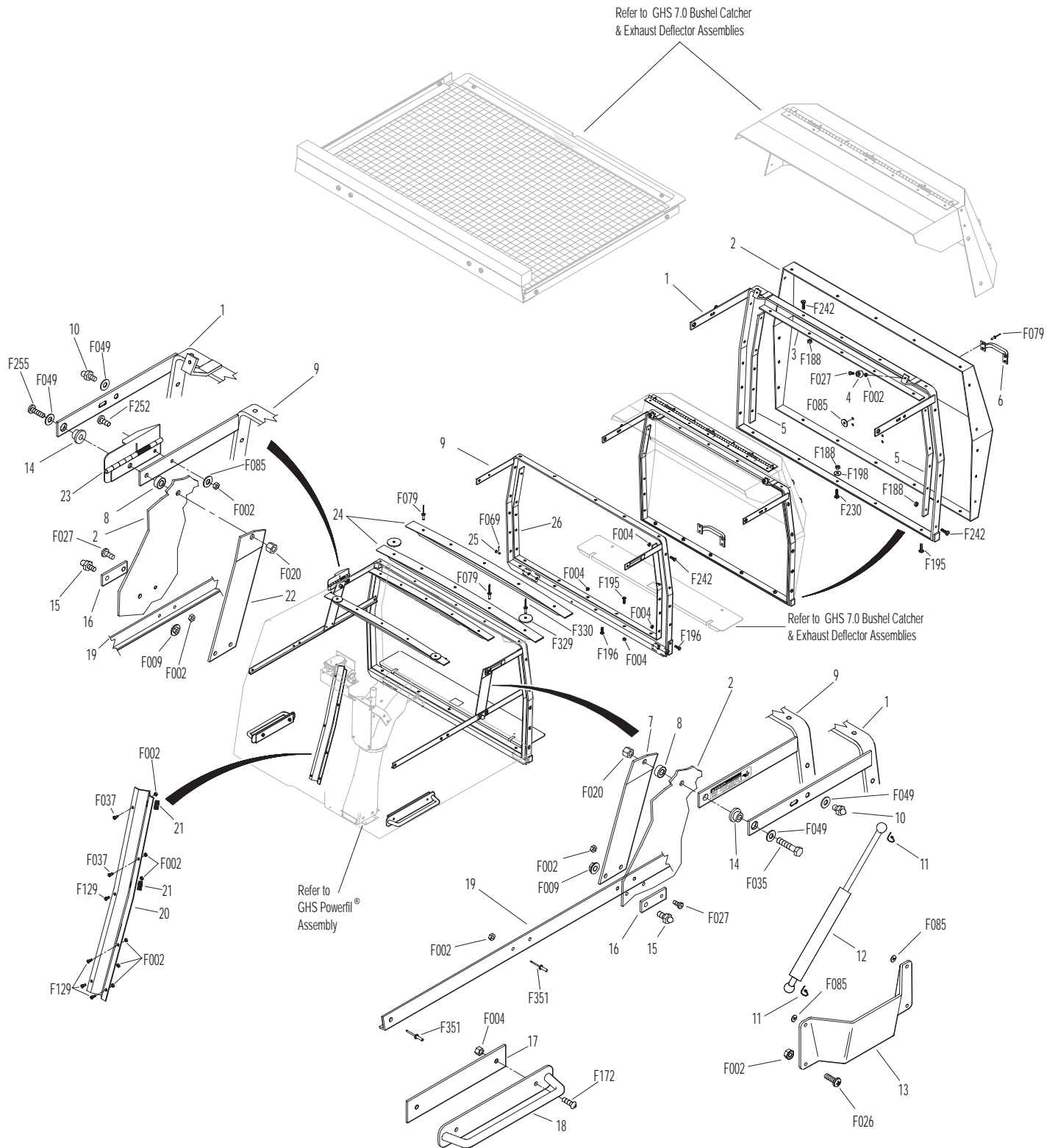

# INSTRUMENT PANEL ASSEMBLY (MT)

ITEM NO.	PART NO.	DESCRIPTION	NO. REQ'D	ITEM NO.	PART NO.	DESCRIPTION	NO. REQ'D
<b>Instrument Panel Assembly</b>				20	8536	Warning Horn	1
1	7307-2	Instrument Panel Cover (Optional)	**	21	8960-15	Ignition Switch (with Keys) (Includes Items # 23, 24 & F349)	1
	8306-4	Instrument Panel Assembly (Includes Items # 2-12, 14, 21, 22, 24-26, F228, F250, F251 & F349)	1	22	8996-2	Red Indicator Light Assembly (Includes Items # 25 & 26)	2
2	7307	Panel Frame	1	23	7854	Plastic Tip, Red	1
3	8823-2	Decal, Instrument Panel	1	24	8960-3	Key Set W/Umbrella	*
4	8820-13	Panel Faceplate	1	25	8996-4	Red Indicator Lens	2
5	7386	Panel Gasket	1	26	8996-3	Indicator Bulb (Replacement for P/N 8996-2)	*
6	6941	Relay Switch (30/40 Amp)	2	<b>Fasteners</b>			
7	7941-3	Boot, Circuit Breaker	1		F004	1/4-20 Keps Nut	6
8	7941-5	Circuit Breaker (7 Amp)	1		F228	#6 x 5/8 PPHSMS, SS	8
9	5995-2	Switch Boot	1		F238	J Clip, Instrument Panel C15520-6A	8
10	5995	Toggle Switch (Off-On)	1		F250	6-32 x 3/8 PPHMS	2
11	8997	Voltmeter Gauge	1		F251	6-32 Keps Nut	2
12	8990-1	Hourmeter (SenDec)	1		F349	Washer .835 ID 1.122 OD, SS	1
13	5975-1	Cable Tie (18# x 3-3/4")	2	* Service Part Only			
14	8945-3	Wire Harness, Instrument Panel	1	** May be ordered as an option. Contact your Walker dealer.			
15	7307-16	Lining 1/8, Panel Box	1	<b>NOTE:</b> Refer to <b>ELECTRICAL CONNECTORS</b> , Page 64 for identification of all Electrical Wiring Service Parts.			
16	7391	Panel Box Mount Plate	2				
17	7977-1	Grommet (1/8 x 1-1/16)	1				
18	7307-1	Shock Mount (1.0 x .25)	3				
19	8385	Panel Box W/Graphic	1				

# INSTRUMENT PANEL ASSEMBLY (MT)

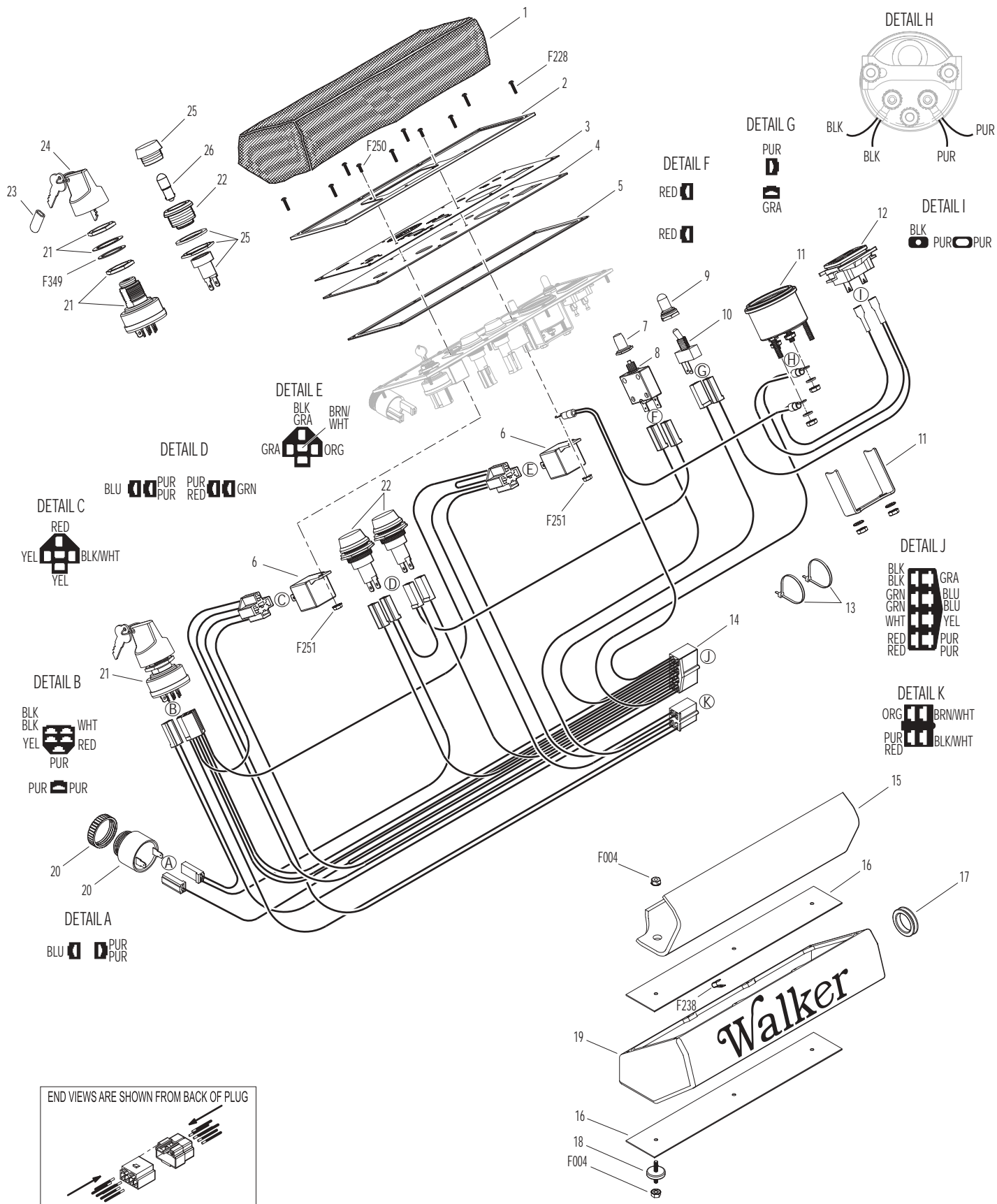

Effective Date 09-15-05

Use only genuine Walker® replacement parts.

# INSTRUMENT PANEL ASSEMBLY (MTL)

ITEM NO.	PART NO.	DESCRIPTION	NO. REQ'D	ITEM NO.	PART NO.	DESCRIPTION	NO. REQ'D
<b>Instrument Panel Assembly</b>				20	8960-3	Key Set W/Umbrella	*
1	7307-2	Instrument Panel Cover (Optional)	**	21	7854	Plastic Tip, Red	1
	8306-6	Instrument Panel Assembly (Includes Items # 2-5, 7-20, 28, F025, F228, F250, F251 & F349)	1	22	7307-1	Shock Mount (1.0 x .25)	3
2	7307	Panel Frame	1	23	7391	Panel Box Mount Plate	2
3	8823-4	Decal, Instrument Panel	1	24	8385	Panel Box W/Graphic	1
4	8820-2	Panel Faceplate	1	25	7977-1	Grommet (1/8 x 1-1/16)	1
5	7386	Panel Gasket	1	26	7307-16	Lining 1/8, Panel Box	1
6	8960-15	Ignition Switch (with Keys) (Includes Items # 20, 21 & F349)	1	27	8536	Warning Horn	1
7	8996-2	Red Indicator Light Assembly (Includes Items # 18 & 19)	2	28	6941	Relay Switch (30/40 Amp)	3
8	7941-3	Boot, Circuit Breaker	2	<b>Fasteners</b>			
9	7941-5	Circuit Breaker (7 Amp)	1	F002	10-24 Keps Nut		1
10	7941-2	Circuit Breaker (10 Amp)	1	F004	1/4-20 Keps Nut		6
11	8990-1	Hourmeter (SenDec)	1	F025	10-24 x 3/8 PPHMS		1
12	5995	Toggle Switch (Off-On)	1	F228	#6 x 5/8 PPH SMS, SS		8
13	5995-2	Switch Boot	1	F238	J Clip, Instrument Panel C15520-6A		8
14	7306-14	Water Temperature Gauge	1	F250	6-32 x 3/8 PPHMS		2
15	8997	Voltmeter Gauge	1	F251	6-32 Keps Nut		2
16	8945-4	Wire Harness, Instrument Panel	1	F349	Washer .835 ID, 1.122 OD, SS		1
17	5975-1	Cable Tie (18# x 3-3/4")	2	* Service Part Only			
18	8996-4	Red Indicator Lens	2	** May be ordered as an option. Contact your Walker dealer.			
19	8996-3	Indicator Bulb (Replacement for P/N 8996-2)	*	<b>NOTE:</b> Refer to <b>ELECTRICAL CONNECTORS</b> , Page 64 for identification of all Electrical Wiring Service Parts.			



# INSTRUMENT PANEL ASSEMBLY (MTL)

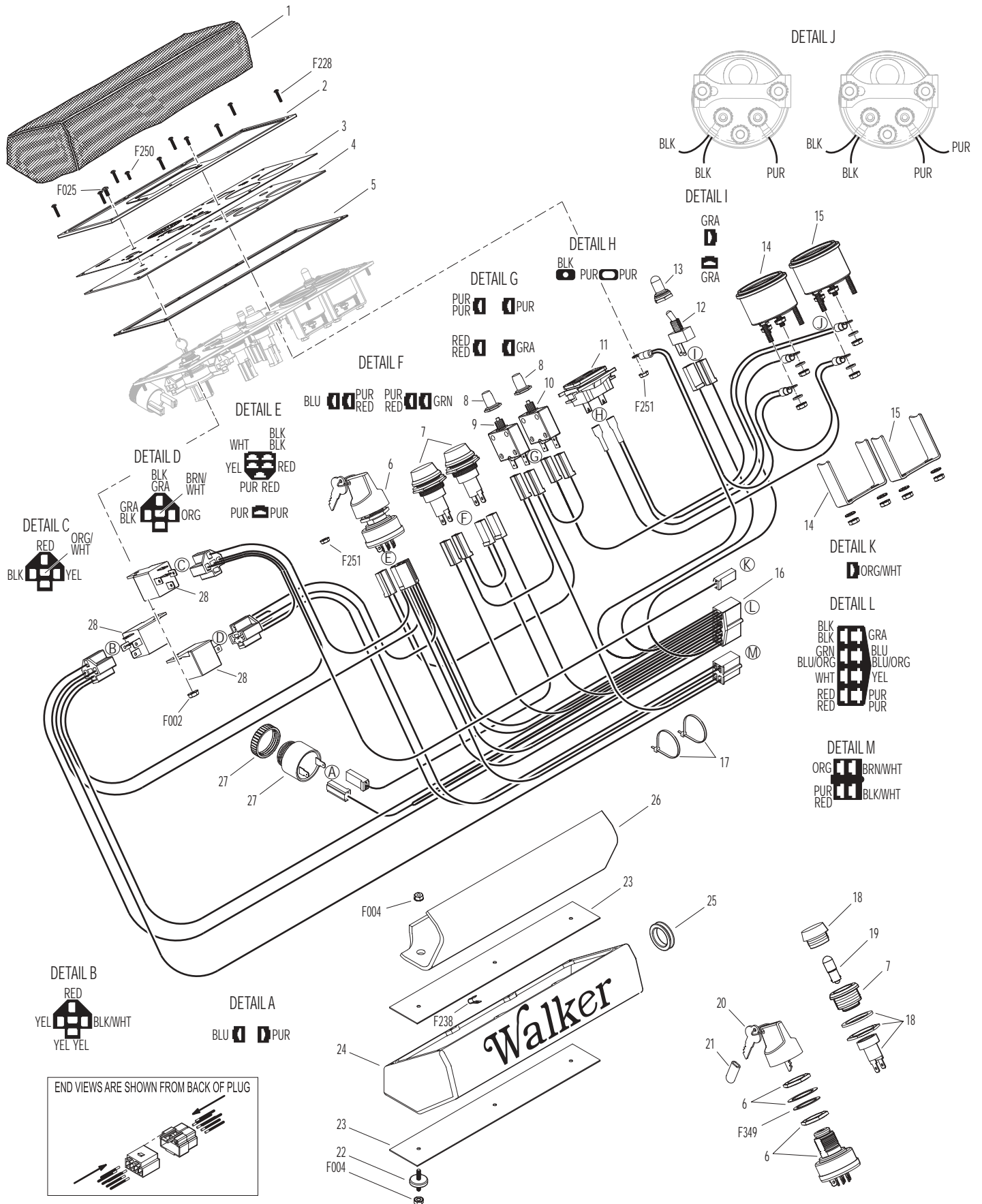

Effective Date 09-15-05

Use only genuine Walker® replacement parts.

# INSTRUMENT PANEL ASSEMBLY (MTEFI)

ITEM NO.	PART NO.	DESCRIPTION	NO. REQ'D	ITEM NO.	PART NO.	DESCRIPTION	NO. REQ'D
<b>Instrument Panel Assembly</b>				20	8996-6	Amber Indicator Lens	1
1	7307-2	Instrument Panel Cover (Optional)	**	21	8996-10	Amber Indicator Light Assembly (Includes Items # 16 & 20)	1
	8306-5	Instrument Panel Assembly (Includes Items # 2-12, 14-21, 27, 28, F228, F250, F251 & F349)	1	22	7307-1	Shock Mount (1.0 x .25)	3
2	7307	Panel Frame	1	23	7391	Panel Box Mount Plate	2
3	8823-3	Decal, Instrument Panel	1	24	8385	Panel Box W/Graphic	1
4	8820-16	Panel Faceplate	1	25	7977-1	Grommet (1/8 x 1-1/16)	1
5	7386	Panel Gasket	1	26	7307-16	Lining 1/8, Panel Box	1
6	8996-2	Red Indicator Light Assembly	2	27	8536	Warning Horn	1
7	8990-1	Hourmeter (SenDec)	1	28	8997	Voltmeter Gauge	1
8	5995-2	Switch Boot	1	<b>Fasteners</b>			
9	5995	Toggle Switch (Off-On)	1	F004	1/4-20 Keps Nut		6
10	6941	Relay Switch (30/40 Amp)	2	F228	#6 x 5/8 PPH SMS, SS		8
11	7941-3	Boot, Circuit Breaker	1	F238	J Clip, Instrument Panel C15520-6A		8
12	7941-5	Circuit Breaker (7 Amp)	1	F250	6-32 x 3/8 PPHMS		2
13	5975-1	Cable Tie (18# x 3-3/4")	2	F251	6-32 Keps Nut		2
14	8945-3	Wire Harness, Instrument Panel	1	F349	Washer .835 ID, 1.122 OD, SS		1
15	8996-4	Red Indicator Lens	2	* Service Part Only			
16	8996-3	Indicator Bulb (Replacement for P/N 8996-2)	*	** May be ordered as an option. Contact your Walker dealer.			
17	8960-3	Key Set W/Umbrella	*	<b>NOTE:</b> Refer to <b>ELECTRICAL CONNECTORS</b> , Page 64 for identification of all Electrical Wiring Service Parts.			
18	7854	Plastic Tip, Red	1				
19	8960-15	Ignition Switch (with Keys) (Includes Items # 17, 18 & F349)	1				

# INSTRUMENT PANEL ASSEMBLY (MTEFI)

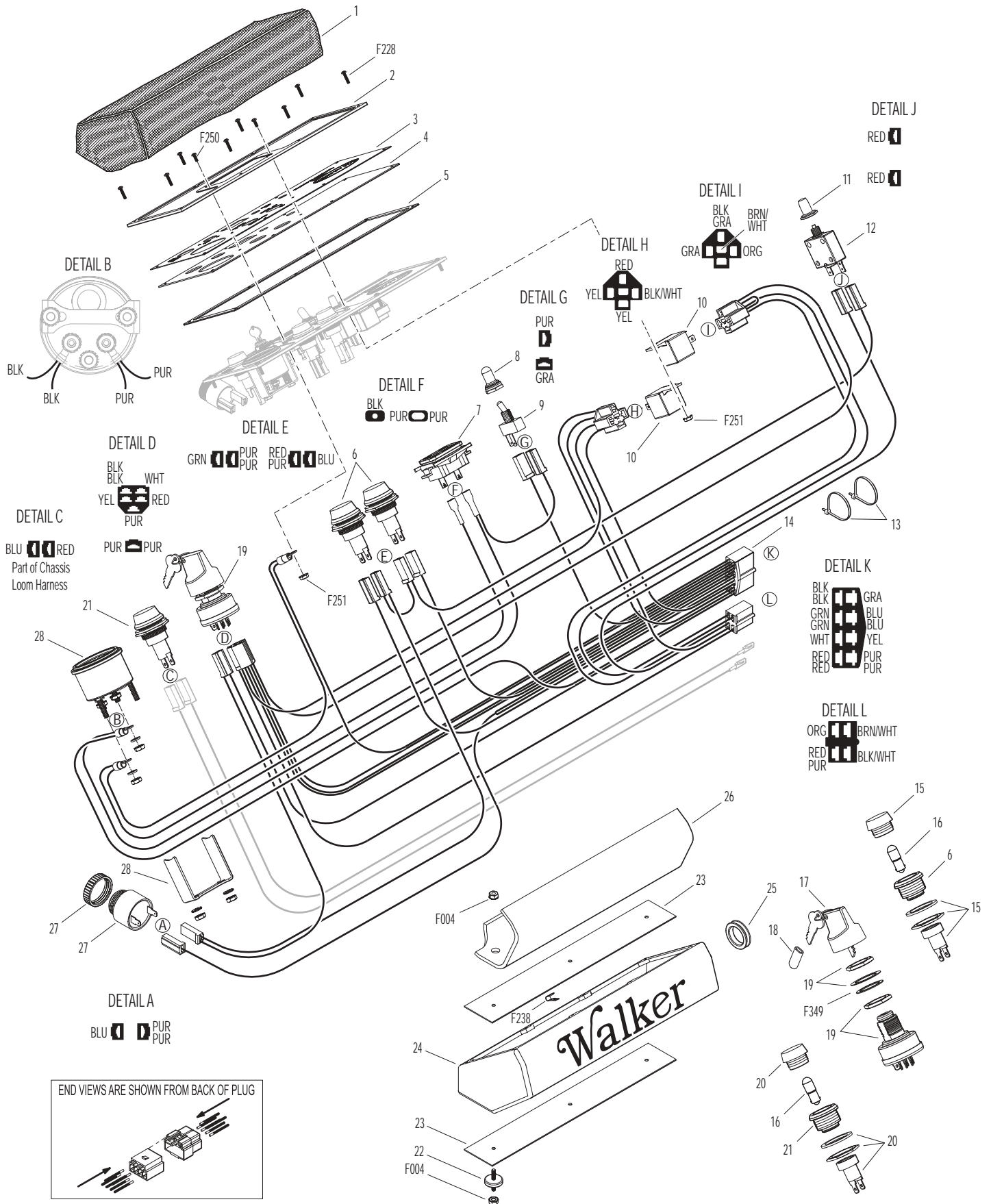

Effective Date 09-15-05

Use only genuine Walker® replacement parts.

## INSTRUMENT PANEL ASSEMBLY (MTLEFI)

ITEM NO.	PART NO.	DESCRIPTION	NO. REQ'D	ITEM NO.	PART NO.	DESCRIPTION	NO. REQ'D
<b>Instrument Panel Assembly</b>				21	8996-10	Amber Indicator Light Assembly (Includes Items # 19 & 20)	1
1	7307-2	Instrument Panel Cover (Optional)	**	22	8960-3	Key Set W/Umbrella	*
	8306-7	Instrument Panel Assembly (Includes Items # 2-16, 18-21, 29, 30, F025, F228, F250, F251 & F349)	1	23	7854	Plastic Tip, Red	1
2	7307	Panel Frame	1	24	7307-1	Shock Mount (1.0 x .25)	3
3	8823-5	Decal, Instrument Panel	1	25	7391	Panel Box Mount Plate	2
4	8820-3	Panel Faceplate	1	26	8385	Panel Box W/Graphic	1
5	7386	Panel Gasket	1	27	7977-1	Grommet (1/8 x 1-1/16)	1
6	8960-15	Ignition Switch (with Keys) (Includes Items # 22, 23 & F349)	1	28	7307-16	Lining 1/8, Panel Box	1
7	8996-2	Red Indicator Light Assembly (Includes Items # 18 & 19)	2	29	8536	Warning Horn	1
8	7941-3	Boot, Circuit Breaker	2	30	6941	Relay Switch (30/40 Amp)	3
9	7941-5	Circuit Breaker (7 Amp)	1	<b>Fasteners</b>			
10	7941-2	Circuit Breaker (10 Amp)	1	F002	10-24 Keps Nut		3
11	8990-1	Hourmeter (SenDec)	1	F004	1/4-20 Keps Nut		6
12	5995	Toggle Switch (Off-On)	1	F025	10-24 x 3/8 PPHMS		3
13	5995-2	Switch Boot	1	F228	#6 x 5/8 PPH SMS, SS		8
14	7306-14	Water Temperature Gauge	1	F238	J Clip, Instrument Panel C15520-6A		8
15	8997	Voltmeter Gauge	1	F250	6-32 x 3/8 PPHMS		2
16	8945-5	Wire Harness, Instrument Panel	1	F251	6-32 Keps Nut		2
17	5975-1	Cable Tie (18# x 3-3/4")	2	F349	Washer .835 ID, 1.122 OD, SS		1
18	8996-4	Red Indicator Lens	2	* Service Part Only			
19	8996-3	Indicator Bulb (Replacement for P/N 8996-2)	*	** May be ordered as an option. Contact your Walker dealer.			
20	8996-6	Amber Indicator Lens	1	<b>NOTE:</b> Refer to <b>ELECTRICAL CONNECTORS</b> , Page 64 for identification of all Electrical Wiring Service Parts.			

# INSTRUMENT PANEL ASSEMBLY (MTLEFI)

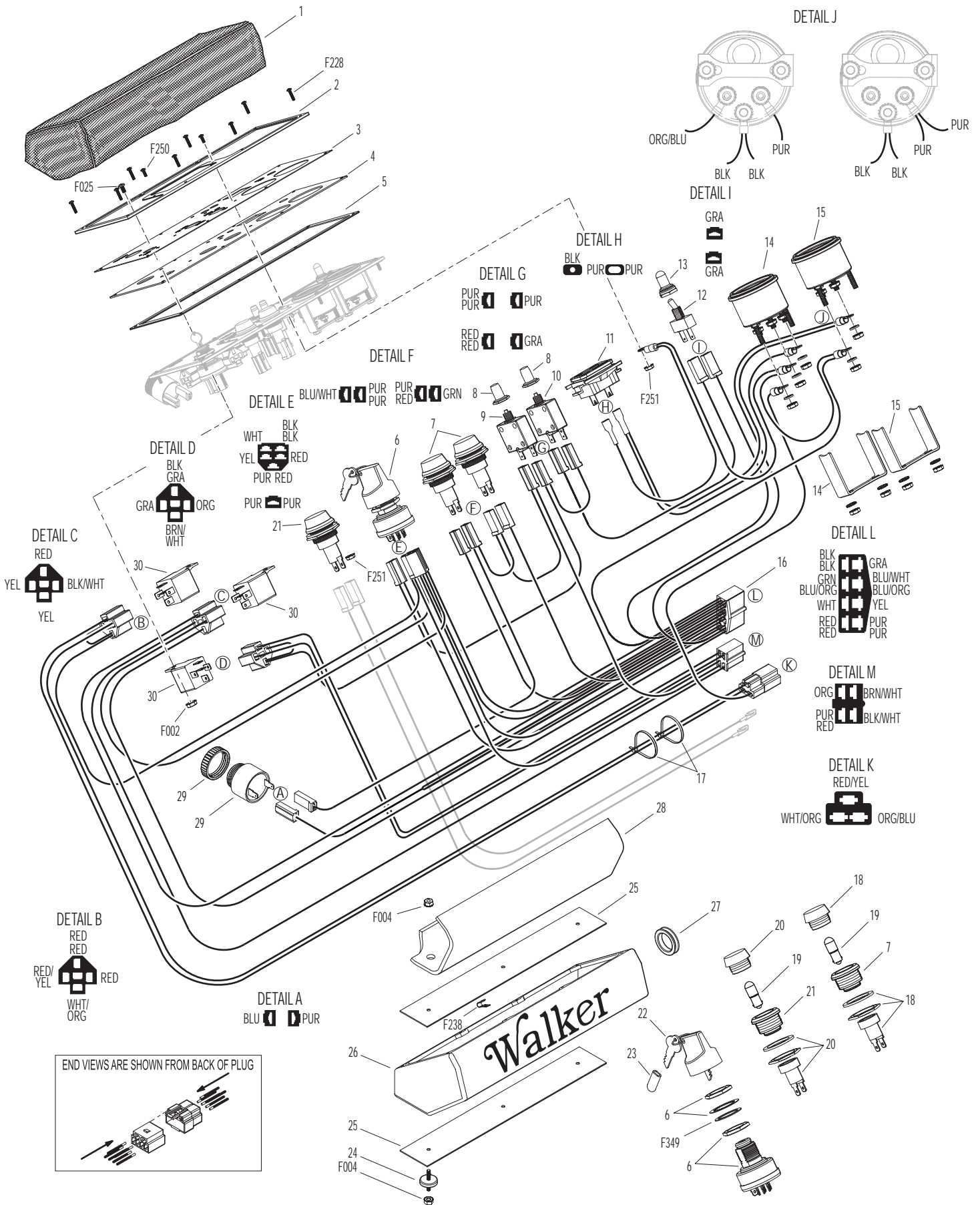

Effective Date 09-15-05

Use only genuine Walker® replacement parts.

# ELECTRICAL ASSEMBLY (MT)

ITEM NO.	PART NO.	DESCRIPTION	NO. REQ'D	ITEM NO.	PART NO.	DESCRIPTION	NO. REQ'D
<b>Harness Assembly</b>				<b>Fasteners</b>			
1	5975-3	Cable Tie (50# x 7")	6	F002		10-24 Keps Nut	10
2	5942-4	PTO Safety Switch (Normal Open)	1	F004		1/4-20 Keps Nut	4
3	5833	Cable Clamp (1/4)	1	F009		5/16-18 Whiz Locknut	1
4	8940-3	Wire Harness	1	F019		1/4-20 ESNA Wing Nut	2
5	5832	Cable Clamp (1/2)	5	F025		10-24 x 3/8 PPHMS	4
6	7944	7.0 Wire Harness	1*	F026		10-24 x 1/2 PPHMS	3
	8950	9.5 Wire Harness	1*	F031		1/4-20 x 5/8 Hex Bolt	2
7	7833-2	Cable Clamp (1 x 1/4)	2	F032		1/4-20 x 3/4 Hex Bolt	2
8	6941	Relay Switch (30/40 Amp)	1	F050		1/4 SAE Washer	4
9	7948-1	Time Delay Module	1	F061		1/4 Star Lock Washer	1
10	7948-5	Time Delay Harness	1	F078		A/A64D Aluminum Pop Rivet	2
11	8941	Circuit Breaker (30 Amp) Auto Reset/Sealed	1	F079		A/A66D Aluminum Pop Rivet	2
12	8943	Positive Battery Lead Wire (Red)	1	F085		3/16 Rivet Backup Washer	1
13	5942-5	Safety Switch (Normal Open)	1	F093		5/16-18 x 1 Hex Bolt	1
14	5975-1	Cable Tie (18# x 3-3/4")	3	F124		10-32 x 3/8 Taptite Machine Screw	2
15	5941-5	Safety Switch (Normal Open)	1	F129		10-24 x 1/2 PTHMS	1
16	7203-6	Riser Plate, Seat Switch	1	F284		M6 x 1.0 x 8 SCH Screw	1
17	5977-6	Grommet (1 x 1-1/4)	1				
<b>Battery Assembly</b>				* Used on GHS Models with 7.0 Bushel Catcher only. When Optional GHS 9.5 Bushel Catcher is purchased, this part is replaced by P/N 8950 (9.5 Catcher Wire Harness).			
18	6923	Negative Battery Cable	1	<b>NOTE:</b> Refer to <b>ELECTRICAL CONNECTORS</b> , Page 64 for identification of all Electrical Wiring Service Parts.			
19	5933	Battery Terminal Insul., Red (+)	1				
20	5844	Battery Hold-Down Bar	1				
21	5839	Hook Bolt	2				
22	6392	Battery Protector Plate	1				
23	7390-1	Battery Pan	1				
24	7910	Battery (12V/340CCA/Dry)	1				
25	5932	Battery Terminal Insul., Black (-)	1				
26	5975-5	Wire Clip, Self-Mount	1				

# ELECTRICAL ASSEMBLY (MT)

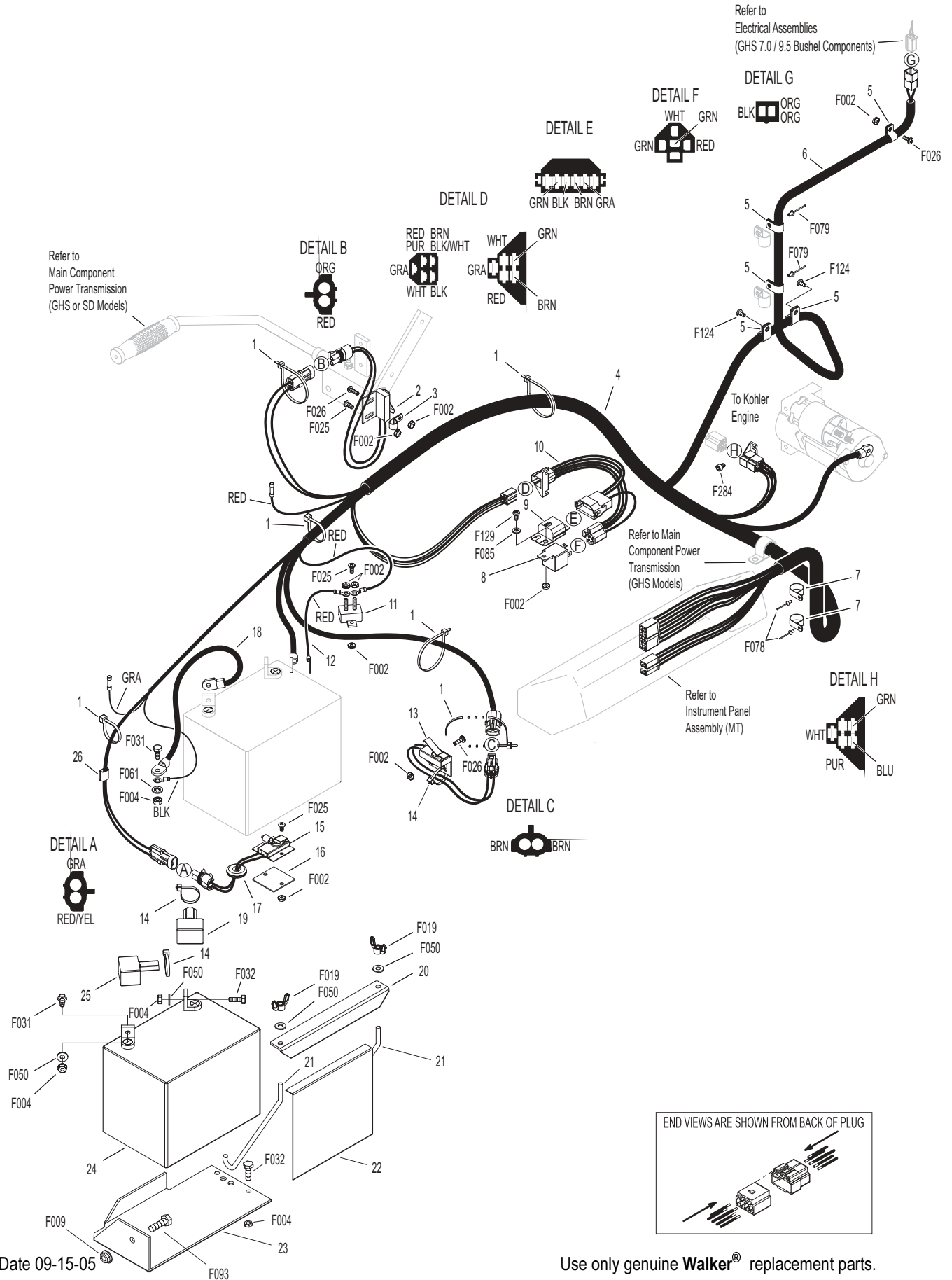

Effective Date 09-15-05

Use only genuine Walker® replacement parts.



# ELECTRICAL ASSEMBLY (MTL)

ITEM NO.	PART NO.	DESCRIPTION	NO. REQ'D	ITEM NO.	PART NO.	DESCRIPTION	NO. REQ'D
<b>Electrical Assembly</b>				<b>Fasteners</b>			
1	8940-4	Wiring Harness	1	F002		10-24 Keps Nut	7
2	5975-3	Cable Tie (50# x 7")	1	F004		1/4-20 Keps Nut	1
3	7428-1	Fan Control Module W/P Plug	1	F025		10-24 x 3/8 PPHMS	2
4	7958-3	Washer (.209 ID x .620 OD)	2	F027		10-24 x 5/8 PPHMS	2
5	8941	Circuit Breaker (30 Amp) Auto Reset/Sealed	1	F050		1/4 SAE Washer	1
6	6941	Relay Switch (30/40 Amp)	1	F061		1/4 Star Washer	1
7	5975-1	Cable Tie (18# x 3-3/4")	3	F090		1/4-20 x 2-1/2 Hex Bolt	1
8	7306-10	Switch (235 Deg., 1/4-18 NPT)	1	F116		1/4-20 x 1-1/4 Hex Bolt	1
9	7306-11	Switch (205 Deg., 3/8-18 NPT)	1	F182		1/4 x 5/8 x 1/8 Washer	1
10	5975-7	Cable Tie (50# x 11")	1	F188		1/4-20 Self-Locking Nut	1
11	7433	Resistor, Ceramic / .4 OHM	1	<b>NOTE:</b> Refer to <b>ELECTRICAL CONNECTORS</b> , Page 64 for identification of all Electrical Wiring Service Parts.			



# ELECTRICAL ASSEMBLY (MTL)

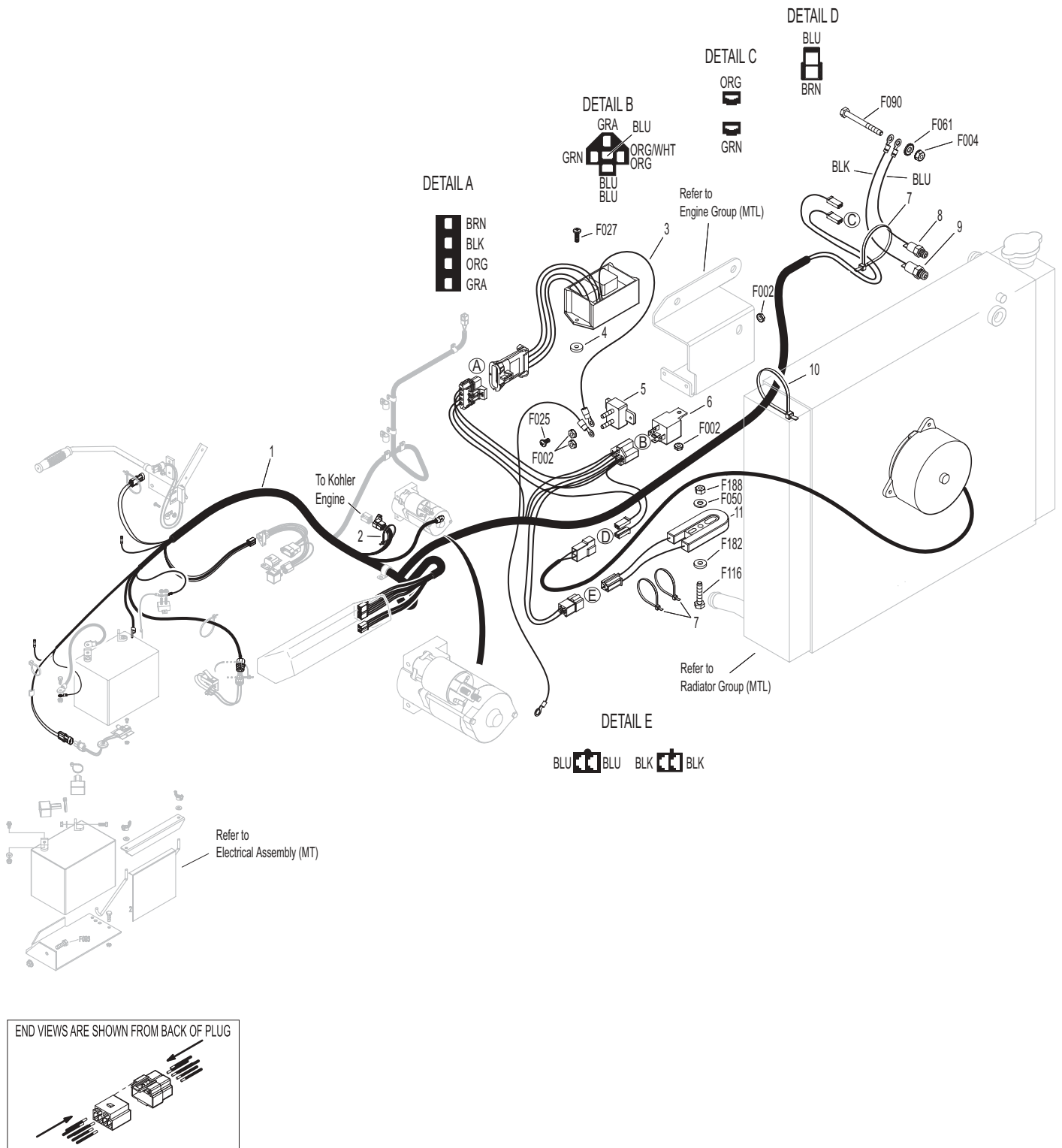

# ELECTRICAL ASSEMBLY (MTEFI)

ITEM NO.	PART NO.	DESCRIPTION	NO. REQ'D	ITEM NO.	PART NO.	DESCRIPTION	NO. REQ'D
<b>Electrical Assembly</b>				<b>Fasteners</b>			
1	8940-16	Wire Harness, Ext. Fuel Pump	1	F002		10-24 Keps Nut	2
2	5975-1	Cable Tie (18# x 3-3/4")	1	F063		3/8 Internal Star Lock Washer	1
3	NS	Fuse Holder (Kohler)	3	F103		10-24 x 2 PTHMS	1
4	6941-4	30 Amp Fuse	1	F106		3/8-16 x 5/8 Hex Bolt	1
5	NS	Relay (Kohler)	1	F284		M6 x 1.0 x 8 SHC Screw	1
6	6941-1	20 Amp Fuse	1	F361		10-24 x 2-1/2 Hex Bolt	1
7	6941-3	10 Amp Fuse	1				
8	NS	ECU Harness Clip	1				
9	NS	ECU (Kohler)	1				
10	5975-8	Cable Tie (50# x 17-1/2")	1				

**NOTE:** Refer to **ELECTRICAL CONNECTORS**, Page 64 for identification of all Electrical Wiring Service Parts.

# ELECTRICAL ASSEMBLY (MTEFI)

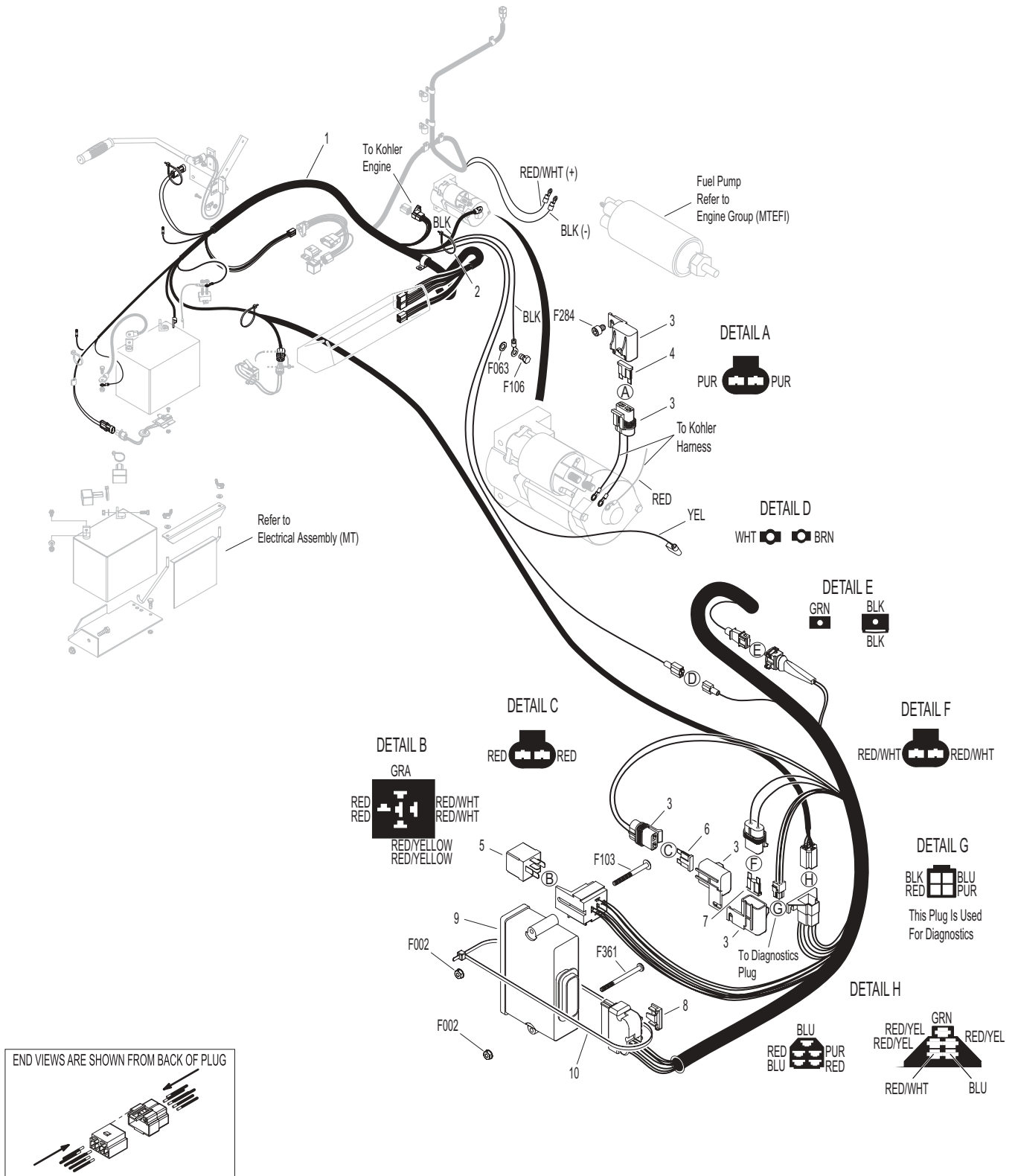

Effective Date 09-15-05

Use only genuine Walker® replacement parts.

## ELECTRICAL ASSEMBLY (MTLEFI)

ITEM NO.	PART NO.	DESCRIPTION	NO. REQ'D	ITEM NO.	PART NO.	DESCRIPTION	NO. REQ'D
<b>Electrical Assembly</b>				<b>Fasteners</b>			
1	8940-6	Wiring Harness	1	F002		10-24 Keps Nut	7
2	5975-1	Cable Tie (18# x 3-3/4")	4	F004		1/4-20 Keps Nut	1
3	7428-1	Fan Control Module W/P Plug	1	F025		10-24 x 3/8 PPHMS	3
4	7958-2	Resistor Mount Plate	1	F026		10-24 x 1/2 PPHMS	2
5	7958-3	Washer (.209 ID x .620 OD)	2	F027		10-24 x 5/8 PPHMS	2
6	7941	Circuit Breaker 40 Amp (Auto Reset/Sealed)	1	F050		1/4 SAE Washer	1
7	6941	Relay Switch (30/40 Amp)	1	F061		1/4 Star Washer	1
8	7427-12	Brass Pipe Plug (1/4 NPTF)	1	F063		3/8 Internal Star Lock Washer	1
9	7306-11	Switch (205 Deg., 3/8-18 NPT)	1	F090		1/4-20 x 2-1/2 Hex Bolt	1
10	5975-7	Cable Tie (50# x 11")	1	F102		10-24 x 1-1/2 PTHMS	2
11	7433	Resistor, Ceramic / .4 OHM	1	F103		10-24 x 2 PTHMS	1
12	NS	Fuse Holder (Kohler)	3	F106		3/8-16 x 5/8 Hex Bolt	1
13	6941-4	30 Amp Fuse	1	F116		1/4-20 x 1-1/4 Hex Bolt	1
14	NS	ECU Harness Clip	1	F182		1/4 x 5/8 x 1/8 Washer	1
15	NS	Relay (Kohler)	1	F188		1/4-20 Self-Locking Nut	1
16	6941-3	10 Amp Fuse	1	F195		1/4-20 x 3/4 PPHMS, SS	1
17	6941-1	20 Amp Fuse	1	F284		M6 x 1.0 x 8 SHC Screw	1
18	8940-7	ECU Mount Plate	1				
19	NS	ECU (Kohler)	1				

**NOTE:** Refer to **ELECTRICAL CONNECTORS**, Page 64 for identification of all Electrical Wiring Service Parts.

# ELECTRICAL ASSEMBLY (MTLEFI)

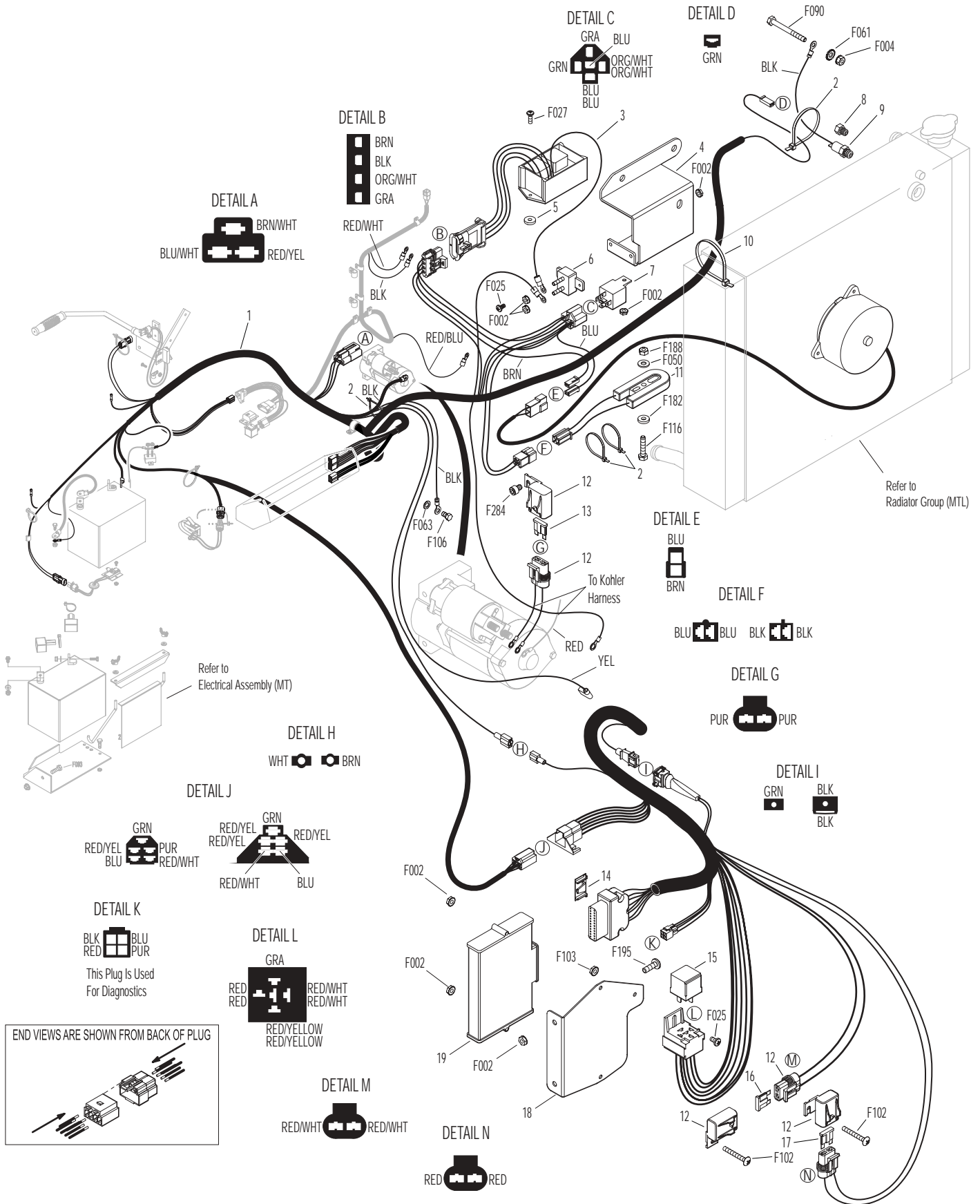

Effective Date 09-15-05

Use only genuine Walker® replacement parts.

# ELECTRICAL ASSEMBLIES (GHS 7.0 / 9.5 BUSHEL COMPONENTS)

ITEM NO.	PART NO.	DESCRIPTION	NO. REQ'D	ITEM NO.	PART NO.	DESCRIPTION	NO. REQ'D
<b>Horn &amp; Harness Channel Assemblies</b>				<b>Fasteners</b>			
1	5975-3	Cable Tie (50# x 7")	2	F002		10-24 Keps Nut	5
2	5536-2	Horn, Full Signal	*	F025		10-24 x 3/8 PPHMS	1
<b>Harness &amp; Grass-Pak® Switch Assemblies</b>				F037		10-24 x 5/8 PTH Screw	2
3	7835	Frame Clip (3/16)	6	F129		10-24 x 1/2 PTHMS	2
4	8950	9.5 Wire Harness	1	F144		4-40 x 1/4 PPHMS	1
	7944	7.0 Wire Harness	*	F145		4-40 Keps Nut	1
5	5833	Cable Clamp (1/4)	2	* Service Part Only			
6	5980-3	Wire, Grass-Pak® Switch	1	<b>NOTE:</b> Refer to <b>ELECTRICAL CONNECTORS</b> , Page 64 for identification of all Electrical Wiring Service Parts.			
7	5592-11	Liquid Tight Plug	1				
8	5592-10	Grass-Pak® Switch Module	1				
	5592-4	Grass-Pak® Switch Assembly (Includes Items # 6, 7 & 8)	*				
9	5594-5	Vane Assembly, Grass-Pak® Switch (Includes Items # F144 & F145)	1				
10	5977-2	Grommet, Cut (1/8 x 3/8)	1				



# ELECTRICAL CONNECTORS

ITEM NO.	PART NO.	DESCRIPTION	NO. REQ'D	ITEM NO.	PART NO.	DESCRIPTION	NO. REQ'D
<b>Electrical Wiring Service Parts</b>				29	7942-1	2-Way Locking Connector, Female	*
1	5996-1	16-14 GA Butt Connector	*	30	7942-2	2-Way Connector, Male	*
2	5996-11	12-10 GA Butt Connector	*	31	7942-3	2-Way Connector, Female	*
3	7942-14	16-14 GA Shrink Connector	*	32	7942-10	2-Way Locking Connector, Male	*
4	7942-13	12-10 GA Shrink Connector	*	33	5940-8	3-Way Connector, Male	*
5	5995-1	Wire Terminal Adapter	*	34	7942-9	3-Way Connector, Male	*
6	5996-4	16-14 GA Bullet Conn., Male	*	35	8944	3-Way Locking Connector, Male	*
7	5996-5	16-14 GA Bullet Conn., Female	*	36	8944-1	3-Way Locking Connector, Female	*
8	5940-4	16-14 GA Spg. Loaded Term., Female	*	37	7942-11	4-Way Connector, Male	*
9	5940-7	Wire Clip, Female	*	38	7942-12	4-Way Connector, Female	*
10	5996	1/4 x 16-14 GA QKS Term., Female	*	39	7942-5	5-Way Connector, Male	*
11	5996-2	3/16 x 22-18 GA QKS Term., Female	*	40	5940-2	5-Way Connector, Male	*
12	7996	16-14 GA QKS Term., Female	*	41	8942-1	5-Way Connector, Female	*
13	5940-5	16-14 GA Spg. Loaded Term., Male	*	42	7942-6	6-Way Connector, Male	*
14	5996-0	1/4 x 22-18 GA QKS Term., Male	*	43	7942-7	6-Way Connector, Male	*
15	5996-18	16-14 GA Ring Term. (#8) Nylon Insulated	*	44	7942-8	8-Way Connector, Male	*
16	7996-1	1/4 x 16-14 GA QKS Term., Male	*	45	8942-2	8-Way Connector, Female	*
17	5996-8	6 GA Ring Lug (5/16)	*	46	8942-3	5-Way Connector, Male	*
18	5996-9	22-18 GA Ring Term., #10	*	47	5940-9	3-Way Connector (M)	*
19	5996-10	16-14 GA Ring Term. (5/16)	*	48	7942-15	6-Way Connector (Female)	*
20	5996-12	12-10 GA Ring Term. (5/16)	*	49	7940-3	Packard Plug (Male)	*
21	5996-13	16-14 GA Ring Term., # 10	*	50	7940-4	Packard Plug (Female)	*
22	5996-15	12-10 GA Ring Term. (1/2)	*				
23	5996-16	6 GA Ring Terminal (1/4)	*				
24	5996-17	16-14 GA Ring Term. (1/4)	*				
25	5996-20	12-10 GA Ring Term. (1/4)	*				
26	5996-21	12-10 GA Ring Term., #10	*				
27	7942-4	Single Connector, Male	*				
28	8942	2-Way Connector, Male	*				

\* Service Part Only

**NOTE:** Not all Electrical Connectors are used with all assemblies.

**NOTE:** Refer to **ELECTRICAL ASSEMBLY**, Page 54 for locations of Wiring Harness and of all Electrical Wiring Service Parts.



# ELECTRICAL CONNECTORS

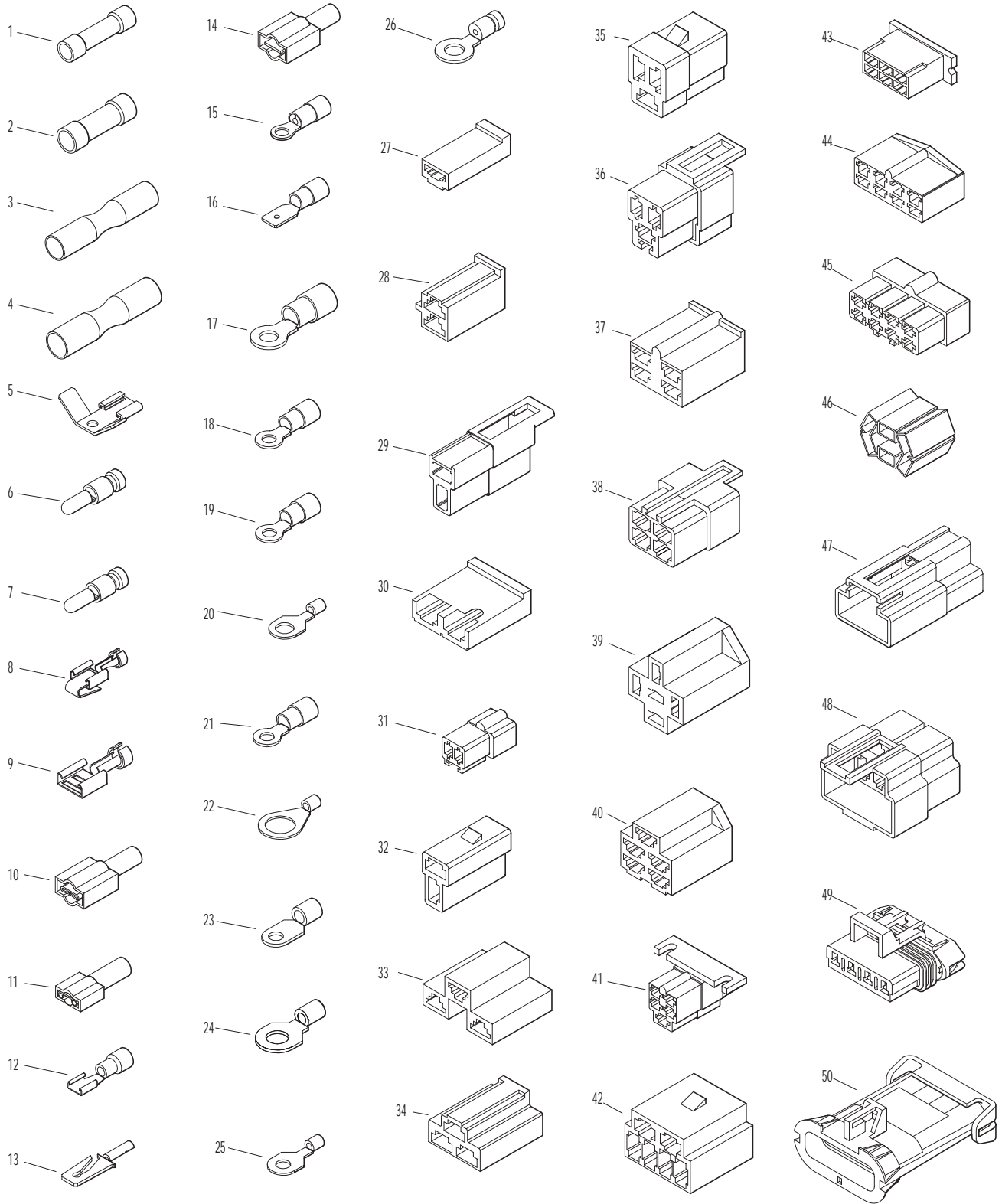

# POWER DECK LIFT KIT

ITEM NO.	PART NO.	DESCRIPTION	NO. REQ'D	ITEM NO.	PART NO.	DESCRIPTION	NO. REQ'D
<b>Kit 8655 Power Deck Lift Option / Kit</b> Includes Items # 1-30, fasteners listed and instructions. May be ordered as a dealer-installed option. Contact your Walker dealer.				<b>Fasteners</b>			
1	8628	Linear Actuator (Includes Items 29, 30 & F320)	1	F002		10-24 Keps Nut	1
2	8655-8	Clamp Bar	1	F004		1/4-20 Keps Nut	9
3	7503-10	Actuator Drive Bushing	1	F009		5/16-18 Whiz Locknut	6
4	8655-11	Bushing (5/8 x 5/16 x 1-1/16)	1	F025		10-24 x 3/8 PPHMS	1
5	8655-10	Bushing (5/8 x 5/16 x 1-1/16)	1	F029		1/4-20 x 1/2 Hex Bolt	8
6	8655-7	Arm, Deck Lift	1	F032		1/4-20 x 3/4 Hex Bolt	1
7	8655-9	Cable Pull	1	F050		1/4 SAE Washer	1
8	8655-12	Bushing (3/4 x 1/4 ID x 3/4)	1	F061		1/4 Star Lock Washer	1
9	5977-1	Grommet (1/8 x 3/8)	1	F068		1/8 x 1 Cotter Pin	1
10	8649	Wire Harness	1	F069		3/32 x 1/2 Cotter Pin	2
11	5975-5	Wire Clip, Self Mount	1	F093		5/16-18 x 1 Hex Bolt	2
12	6623	Toggle Switch	1	F134		AN960816L Washer	1
13	5996-21	12-10 GA Ring Terminal (# 10)	*	F179		1/4-20 x 1 Hex Bolt	1
14	8655-1	Hitch Pin/Cotterless (5/8)	2	F316		5/16-18 x 1-3/4 Hex Bolt	2
15	8655-6	Lift Chain	2	F320		1/8 x 3/4 Split Spring Pin	*
16	8655-5	Cable Mount	2				
17	5996-20	12-10 GA Ring Terminal (1/4)	*				
18	7942-10	2-Way Locking Connector (M)	*				
19	5940-4	16-14 GA Spring-Loaded Terminal (F)	*				
20	8655-3	Cable LH (48")	1				
21	8655-2	Cable RH (38.5")	1				
22	8654	Decal, Deck Lift	1				
23	6623-1	Switch Boot	1				
24	6832	Cable Clamp (9/16 x 1/4)	1				
25	5832	Cable Clamp (1/2)	1				
26	8655-22	Base, Deck Lift	1				
27	8655-4	Clevis Pin (5/16 x 3/4)	2				
28	5975-3	Cable Tie (#50 x 7")	3				
29	7942-1	2-Way Locking Connector (F)	*				
30	5940-5	16-14 GA Spring-Loaded Terminal (M)	*				

\* Service Part Only

**NOTE:** Power Deck Lift is not compatible with Comfort Seat or Suspension Seat.



# ARMREST KIT / TOUCH-UP PAINT / COMFORT SEAT KIT

ITEM NO.	PART NO.	DESCRIPTION	NO. REQ'D
----------	----------	-------------	-----------

**Kit 5885 Armrest Option / Kit**

Includes Items # 1-5, fasteners listed and instructions. May be ordered as a dealer-installed option. Contact your Walker dealer.

1	5886-1	Armrest, RH	1
2	5886-6	Cover Plate, RH	1
3	5887	Mounting Bracket	1
4	5886-5	Cover Plate, LH	1
5	5886-2	Armrest, LH	1
	5888	Armrest Hardware Kit (Includes Items # F305, F306, F307 & F308)	*

**Touch-Up Paint**

6	5866	Touch-Up Paint, Yellow (12 oz. Aerosol)	
7	5867	Touch-Up Paint, Grey (12 oz. Aerosol)	

**Kit 6103-5 Comfort Seat Kit (Cordura)**

Includes Items # 8, 13, fasteners listed and instructions. May be ordered as a dealer-installed option. Contact your Walker dealer.

8	6103-5	Comfort Seat	1
9	7203	Seat Spring Plate	**
10	7223	Compression Spring (1/2 x 1)	**
11	7846	Rubber Washer (3/8 x 1-1/4 x 1/8)	**
12	7204	Shoulder Bolt, Seat Mount	**
13	7203-6	Riser Plate, Seat Switch	***
14	7845	Rubber Bumper (1.375 x .63)	**
15	7440-5	Shock Mount (1-1/4 x 3/4)	**

ITEM NO.	PART NO.	DESCRIPTION	NO. REQ'D
----------	----------	-------------	-----------

**Kit 6103-17 Armrest Option / Kit**

Includes Items # 16, 17 and instructions. Item # 16 is the **Right** side armrest only. Item # 17 is the **Left** side armrest only. Sold only as a complete set and may be ordered together as a factory-installed option or as a kit for dealer installation. Contact your Walker dealer.

16	6103-42	Armrest, RH/Cordura	1
17	6103-41	Armrest, LH/Cordura	1

**Fasteners**

F009	5/16 - 18 Whiz Locknut	**
F026	10-24 x 1/2 PPHMS	2
F227	3/8-1-1/4 x 1/8 Plastic Washer	**
F305	1/4-20 x 3/8 SH Cap Screw	2
F306	3/8-16 x 3/4 Hex Bolt	4
F307	#10 x 5/8 PPHST Screw	2
F308	1-1/4 x 1-5/8 Wave Spring Washer	2

\* Service Part Only

\*\* Reuse existing parts from Seat Assembly. Refer to **BODY / CHASSIS ASSEMBLY (GHS MODELS) MT/MTEFI**, Page 4.

\*\*\* Only one Riser Plate is included with kit. One is reused from Seat Assembly. Refer to **BODY / CHASSIS ASSEMBLY (GHS MODELS) MT/MTEFI**, Page 4.

# ARMREST KIT / TOUCH-UP PAINT / COMFORT SEAT KIT

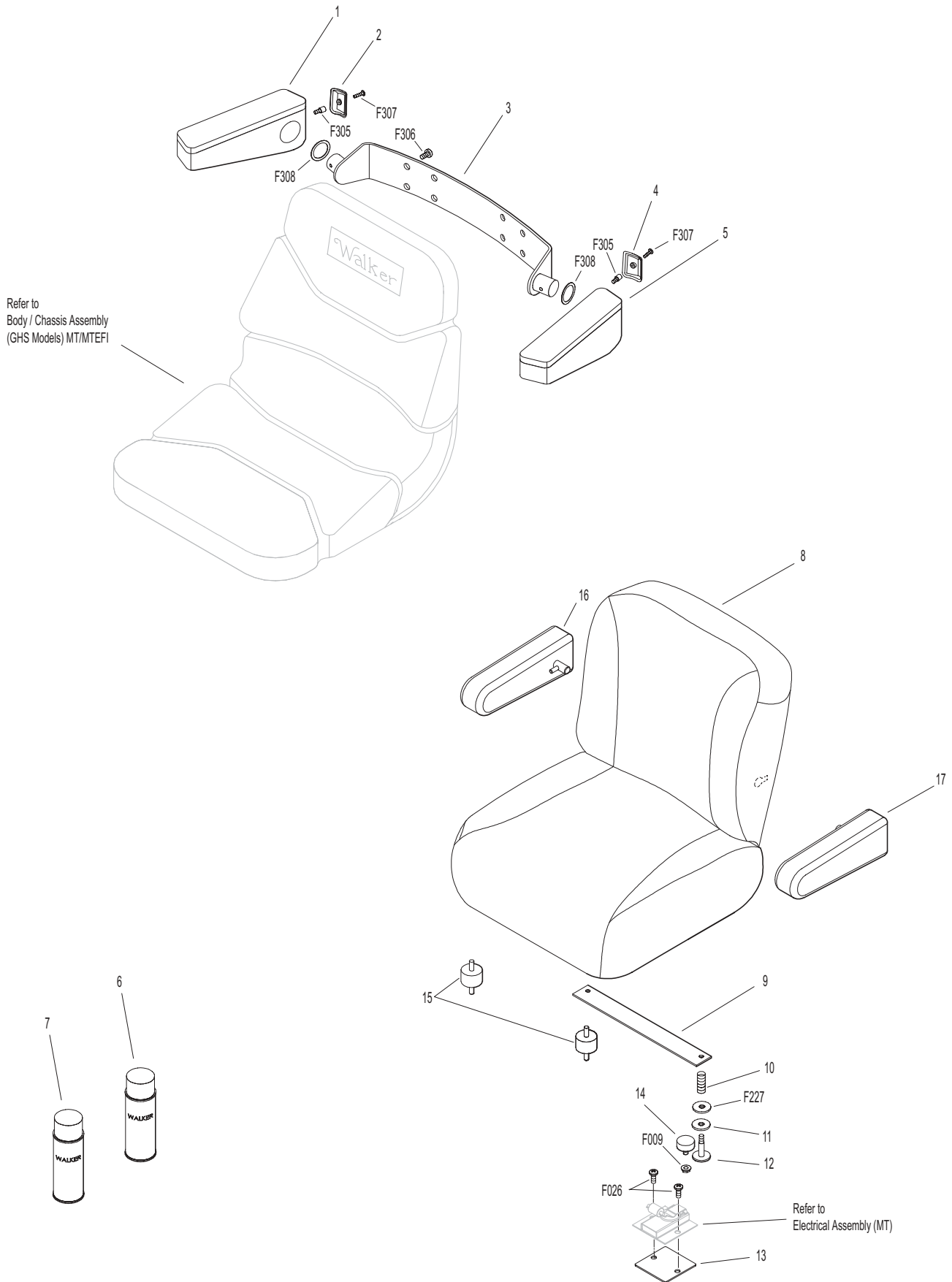

Effective Date 09-15-05

Use only genuine Walker® replacement parts.

# SUSPENSION SEAT KIT

ITEM NO.	PART NO.	DESCRIPTION	NO. REQ'D
----------	----------	-------------	-----------

## Kit 6103-9 Armrest Kit

Includes Items # 1-6 and instructions. May be ordered as a factory-installed option or as a kit for dealer installation. Contact your Walker dealer.

1	6103-92	Armrest, RH/SS	1
2	NS	5/8 Nut Cover	4
3	NS	7/16-20 x 13/4 HHCS	4
4	NS	3/8 SAE Washer	4
5	NS	Bushing, 3/4 x 3/4	4
6	6103-91	Armrest, LH/SS	1

## Kit 6103-25 Suspension Seat Option / Kit

Includes Items # 7-9, 11-13, 17, 20, fasteners listed (except as indicated; refer to **NOTE**) and instructions. May be ordered as a factory-installed option or as a kit for dealer installation. Contact your Walker dealer.

7	6103-11	Suspension Seat	1
8	5941-5	Safety Switch (Normal Open)	*
9	6103-33	Seat Mount Plate, LH	1
10	7223	Compression Spring (1/2 x 1)	2
11	5975-3	Cable Tie (50# x 7")	2
12	5975-1	Cable Tie (18# x 3-3/4")	1
13	6103-23	Wire Harness, Suspension Seat	1
14	7846	Rubber Washer (3/8 x 1-1/4 x 1/8)	2
15	7204	Shoulder Bolt, Seat Mount	2
16	5453-20	Steering Lever Handle (+1"), Adj.	2
17	5977-5	Grommet (5/8)	1
18	5841	Retainer Washer (3/8 x 1-1/4)	2
19	7845	Rubber Bumper (1.375 x 0.63)	2
20	7440-5	Shock Mount (1-1/4 x 3/4)	2
21	6103-34	Seat Mount Plate, RH	1

ITEM NO.	PART NO.	DESCRIPTION	NO. REQ'D
----------	----------	-------------	-----------

## Fasteners

F002	10-24 Keps Nut	4
F009	5/16-18 Whiz Locknut	4
F026	10-24 x 1/2 PPHMS	4
F168	5/16 Split Lock Washer	4
F227	3/8 x 1-1/4 x 1/8 Washer (Plastic)	2
F357	M8 x 16 Hex Bolt	2
F358	M8 x 25 Hex Bolt	2

\* Only one switch is included with kit. One is reused from Seat Assembly. Refer to **BODY / CHASSIS ASSEMBLY (GHS MODELS) MT/MTEFI**, Page 4.

**NOTE:** Reuse items # 8, 10, 14-16, 18, two (2) each of the F002, F009 and F026 fasteners, and item # F227 from Seat Assembly. Refer to **BODY / CHASSIS ASSEMBLY (GHS MODELS) MT/MTEFI**, Page 4.

# SUSPENSION SEAT KIT

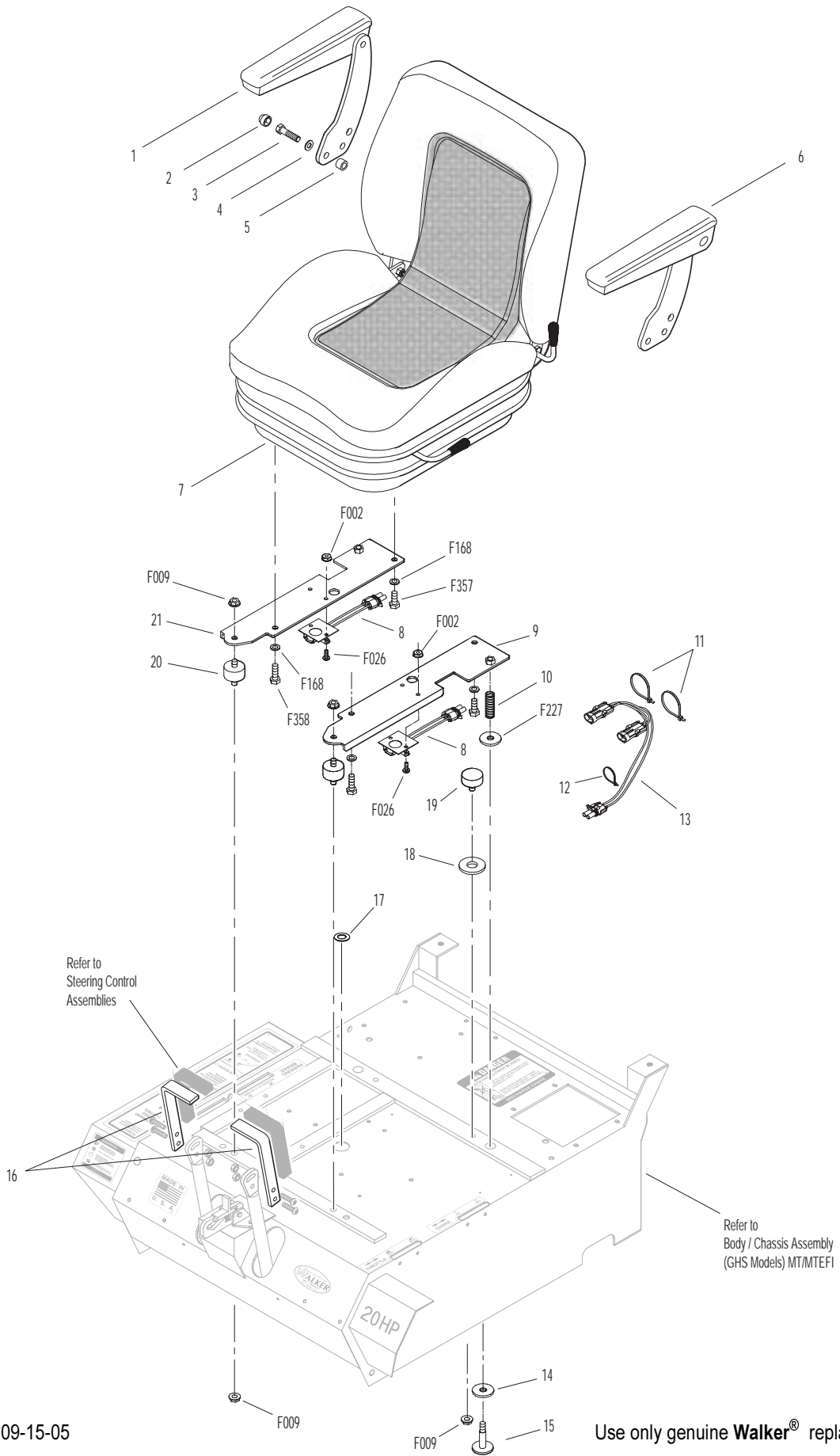

Effective Date 09-15-05

Use only genuine Walker® replacement parts.

## LIGHT KIT / COLD START KIT / SPEED UP KIT

ITEM NO.	PART NO.	DESCRIPTION	NO. REQ'D
----------	----------	-------------	-----------

**Kit 7989-1 Light Option / Kit**

Includes Items # 1-8, fasteners listed and instructions. May be ordered as a dealer-installed option. Contact your Walker dealer.

1	7989-2	Light Assembly (Halogen) (Includes Items # 2 & 4) (Includes Halogen Bulb)	2
	7989-6	Bulb Replacement (Halogen)	*
2	7989-3	Wire Harness Extension	2
3	7834-1	Half U-Wire Clip	4
4	5996-4	16-14 GA Bullet Cntr. (M)	3
5	5996-5	16-14 GA Bullet Cntr. (F)	2
6	7993	Mount Bracket, Lights	1
7	7995-3	Power Lead Wire Assembly (Includes Items # 4, 5, 8, 10 & 11)	1
8	5977-1	Grommet (1/8 x 3/8)	2
9	5975-5	Wire Clip, Self-Mount	3
10	5975-1	Cable Tie (18# x 3-3/4")	1
11	5996	1/4 x 16-14 GA QDF Terminal	1

**Kit 8638 Cold Start Option / Kit**

Includes Items # 12-14, fasteners F004, F029, and instructions.

12	5830	Grease Fitting	1
13	7406-1	Handle Grip, Red	1
14	8638-1	Idler Release (Includes Items # 12 & 13)	1

ITEM NO.	PART NO.	DESCRIPTION	NO. REQ'D
----------	----------	-------------	-----------

**Kit 8247 Speed-Up Option / Kit**

Includes Items # 15, 16 and instructions.

15	5224	Extension Spring (1 x 4)	1
16	7240-1	Jackshaft Drive Pulley (3-1/2/3V) (Includes Items # F067 & F171)	1

Both kits may be ordered as a dealer-installed option. Contact your Walker dealer.

**Fasteners**

F004	1/4-20 Keps Nut	2
F009	5/16-18 Whiz Locknut	2
F029	1/4-20 x 1/2 Hex Bolt	2
F052	5/16 Ext. Star Lock Washer	2
F091	5/16-18 x 5/8 Hex Bolt	2
F171	5/16-18 x 3/8 Set Screw	*

\* Service Part Only

**NOTE:** Upon installation of kit, Item # 8 replaces P/N 5989-4 (Dome Plug, 3/8) and Item # F091 replaces P/N 5989-3 (Dome Plug, 5/16). Dome Plugs are not shown here. Refer to **BODY / CHASSIS ASSEMBLY (GHS MODELS) MT/MTEFI**, Page 4.

**NOTE:** Refer to **ELECTRICAL CONNECTORS**, Page 64 for identification of all Electrical Wiring Service Parts.



# LIGHT KIT / COLD START KIT / SPEED UP KIT

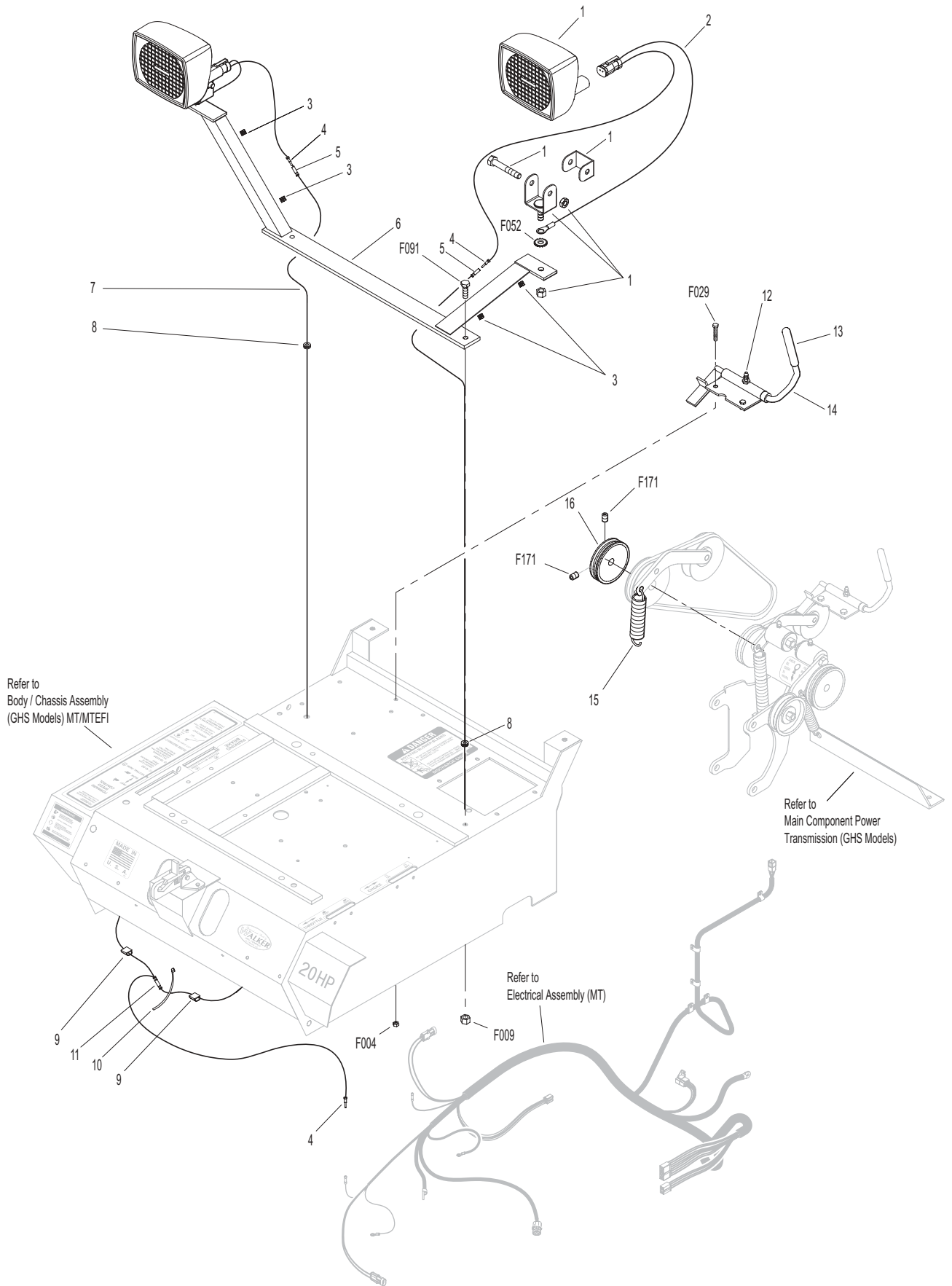

# BLOWER LOCKOUT KIT / CASE-HARDENED BLOWER

ITEM NO.	PART NO.	DESCRIPTION	NO. REQ'D
----------	----------	-------------	-----------

**Kit 6541 Blower Lockout Kit**

Includes Items # 1-7, fasteners and instructions. May be ordered as a kit for dealer installation. Contact your Walker dealer.

1	7854	Plastic Tip, Red	*
2	6541-2	Blower Lockout Rod (Includes Item #1)	1
3	6541-1	Blower Lockout Latch	1
4	5280	Clevis (1/4)	1
5	5281-5	Clevis Pin (1/4 x 0.80)	1
6	6541-3	Blower Lockout Pivot Arm	1
7	6541-4	Blower Lockout Belt Guide	1

ITEM NO.	PART NO.	DESCRIPTION	NO. REQ'D
----------	----------	-------------	-----------

**Kit 6542-15 Case Hardened Blower Option**

Includes Items # 8-13, fasteners and instructions. May be ordered as a kit for dealer installation. Contact your Walker dealer.

8	5268	Bearing W/Collar (3/4)	2
9	6543-15	Case Hardened Blower Housing	1
10	6545-15	Case Hardened Blower Wheel	1
11	6525-2	Faceplate (10" Blower)	1
12	6526	Intake Tube (6-1/2 x 2-1/2)	1
13	6542-50	Decal, "H" (5/8)	1

**Fasteners**

F003	1/4-28 Hex Nut	1
F004	1/4-20 Keps Nut	7
F032	1/4-20 x 3/4 Hex Bolt	1
F074	1/4-20 x 3/8 Set Screw	2
F091	5/16-18 x 5/8 Hex Bolt	1
F186	5/64 x 1/2 Cotter Pin	1
F325	1/4-20 x 3 Hex Bolt	1

\* Service Part Only

# BLOWER LOCKOUT KIT / CASE-HARDENED BLOWER

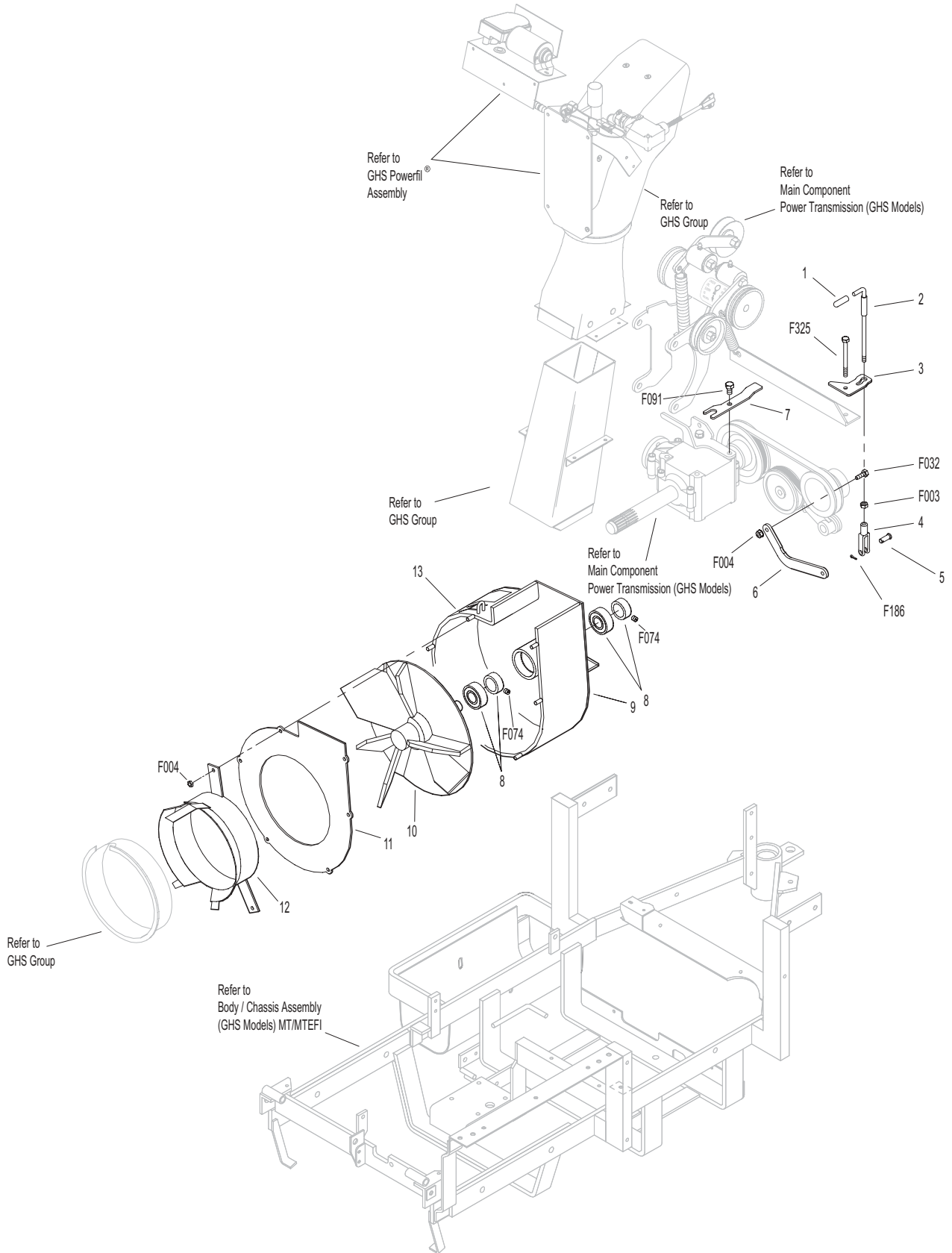

# POWER DUMP KIT (7.0 BUSHEL GHS MODELS ONLY)

ITEM NO.	PART NO.	DESCRIPTION	NO. REQ'D
<b>Kit 7620-13 Power Dump Option / Kit (7.0 Models Only)</b>			
Includes Items # 1-33, fasteners listed and instructions. May be ordered as a factory-installed option or as a kit for dealer installation. Contact your Walker dealer. Not to be used with optional Dump Bag Kits.			
1	5522-20	Hinge Backup Plate/RH/PD	1
2	7620-3	Door Pivot Bushing (9/16 x 1/2)	2
3	7612-2	Door Actuator Arm, RH	1
4	7612-1	Door Actuator Arm, LH	1
5	5522-10	Hinge Backup Plate/LH/PD	1
6	7610-5	Extension Spring (1/4 x 2-7/8)	1
7	7523-2	Clevis Pin (1/4 x 5/8)	2
8	7623	Power Dump Cable	2
9	5975-7	Cable Tie (50# x 11")	1
10	7621	Linear Actuator/7.0	1
11	5552	Ball Joint (1/4-28)	2
12	7628-1	Channel Angle, RH	1
13	7620-9	Roller Wheel	2
14	7629	Channel Angle, LH	1
15	5830	Grease Fitting	3
16	7626-0	Actuator Mount	1
17	7624-1	Roller Bearing Bolt	1
18	5832	Cable Clamp (1/2)	1
19	7627	Front Actuator Mount	1
20	7624	Sealed Needle Bearing	1
21	7630-3	Ram Pivot and Spacer	1
22	7625	Fork	1
23	5975-1	Cable Tie (18# x 3-3/4")	1
24	5975-3	Cable Tie (50# x 7")	5
25	7622	Wire Harness	1
26	6623	Toggle Switch	1
27	6623-1	Switch Boot	1
28	7633	Decal, Power Dump	1
29	8105-3	Rear Body Panel, LH (MT/EFI)	1
	8105-35	Rear Body Panel, LH (MTL)	1
30	8105-6	Rear Body Panel, RH (MT/MTL/EFI)	1
31	7620-12	Cable Rod Guide (7.0)	2
32	7620-6	Cable Guide	2
33	7613	Door Actuator	2

ITEM NO.	PART NO.	DESCRIPTION	NO. REQ'D
<b>Fasteners</b>			
	F002	10-24 Keps Nut	6
	F003	1/4-28 Hex Nut	4
	F004	1/4-20 Keps Nut	4
	F009	5/16-18 Whiz Locknut	4
	F012	3/8-16 Keps Nut	2
	F028	10-24 x 3/4 PPHMS	4
	F029	1/4-20 x 1/2 Hex Bolt	4
	F039	3/8-16 x 1-1/4 Hex Bolt	2
	F050	1/4 SAE Washer	2
	F068	1/8 x 1 Cotter Pin	2
	F069	3/32 x 1/2 Cotter Pin	4
	F079	A/A66D Aluminum Pop Rivet	1
	F085	3/16 Rivet Backup Washer	4
	F093	5/16-18 x 1 Hex Bolt	1
	F111	1/8 x 3/4 Cotter Pin	1
	F128	10-24 x 3/8 PTHMS	2
	F134	AN960816L Washer	4
	F266	1/2 x 2-3/4 Shoulder Bolt	1
	F267	1/2 x 1 x 1/16 Washer	4
	F269	10-32 x 5/8 PTHMS	4
	F270	10-32 Cap Nut	4
	F317	3/16 x 1 Split Spring Pin	2

**NOTE:** Two F009 Fasteners are reused from the Rear Gas Spring Assembly. Refer to **REAR BODY ASSEMBLY (GHS MODELS) MT/MTEFI**, Page 8.

**NOTE:** Refer to **ELECTRICAL CONNECTORS**, Page 64 for identification of all Electrical Wiring Service Parts.



# POWER DUMP KIT (9.5 BUSHEL GHS MODELS ONLY)

ITEM NO.	PART NO.	DESCRIPTION	NO. REQ'D	ITEM NO.	PART NO.	DESCRIPTION	NO. REQ'D	
<b>Kit 8620-1 Power Dump Option / Kit (9.5 Models Only)</b> Includes Items # 1-33, fasteners listed and instructions. May be ordered as a factory-installed option or as a kit for dealer installation. Contact your Walker dealer.				<b>Fasteners</b>				
1	5522-20	Hinge Backup Plate/RH/PD	1	F002		10-24 Keps Nut	6	
2	7620-3	Door Pivot Bushing (9/16 x 1/2)	2	F003		1/4-28 Hex Nut	4	
3	7612-2	Door Actuator Arm, RH	1	F004		1/4-20 Keps Nut	4	
4	7612-1	Door Actuator Arm, LH	1	F009		5/16-18 Whiz Locknut	3	
5	5522-10	Hinge Backup Plate/LH/PD	1	F012		3/8-16 Keps Nut	2	
6	7610-5	Extension Spring (1/4 x 2-7/8)	1	F028		10-24 x 3/4 PPHMS	2	
7	7523-2	Clevis Pin (1/4 x 5/8)	2	F029		1/4-20 x 1/2 Hex Bolt	4	
8	7623-2	Power Dump Cable	2	F039		3/8-16 x 1-1/4 Hex Bolt	2	
9	5975-7	Cable Tie (50# x 11")	1	F050		1/4 SAE Washer	1	
10	7721	Linear Actuator/9.5	1	F068		1/8 x 1 Cotter Pin	2	
11	5552	Ball Joint (1/4-28)	2	F069		3/32 x 1/2 Cotter Pin	4	
12	8620-5	Guard, 9.5 P.D. Motor	1	F079		A/A66D Aluminum Pop Rivet	1	
13	7628-1	Channel Angle, RH	1	F085		3/16 Rivet Backup Washer	4	
14	7620-9	Roller Wheel	2	F093		5/16-18 x 1 Hex Bolt	2	
15	7629	Channel Angle, LH	1	F111		1/8 x 3/4 Cotter Pin	1	
16	5830	Grease Fitting	3	F134		AN960816L Washer	4	
17	7636-1	Actuator Mount, 9.5	1	F266		1/2 x 2-3/4 Shoulder Bolt	1	
18	7624-1	Roller Bearing Bolt	1	F267		1/2 x 1 x 1/16 Washer	4	
19	5832	Cable Clamp (1/2)	1	F269		10-32 x 5/8 PTHMS	4	
20	7627	Front Actuator Mount	1	F270		10-32 Cap Nut	4	
21	7624	Sealed Needle Bearing	1	F317		3/16 x 1 Split Spring Pin	2	
22	7630-3	Ram Pivot and Spacer	1	F337		1/4 - 20 x 5/8 Self Tap Bolt	2	
23	7625	Fork	1					
24	5975-1	Cable Tie (18# x 3-3/4")	1					
25	5975-3	Cable Tie (50# x 7")	5					
26	7622	Wire Harness	1					
27	6623	Toggle Switch	1					
28	6623-1	Switch Boot	1					
29	7633	Decal, Power Dump	1					
30	8105-3	Rear Body Panel, LH (MT/EFI)	1					
	8105-35	Rear Body Panel, LH (MTL)	1					
31	8105-6	Rear Body Panel, RH (MT/MTL/EFI)	1					
32	7620-6	Cable Guide	2					
33	7613	Door Actuator	2					

**NOTE:** Two F009 Fasteners are reused from the Rear Gas Spring Assembly. Refer to **REAR BODY ASSEMBLY (GHS MODELS) MT/MTEFI**, Page 8.

**NOTE:** Refer to **ELECTRICAL CONNECTORS**, Page 64 for identification of all Electrical Wiring Service Parts.

# POWER DUMP KIT (9.5 BUSHEL GHS MODELS ONLY)

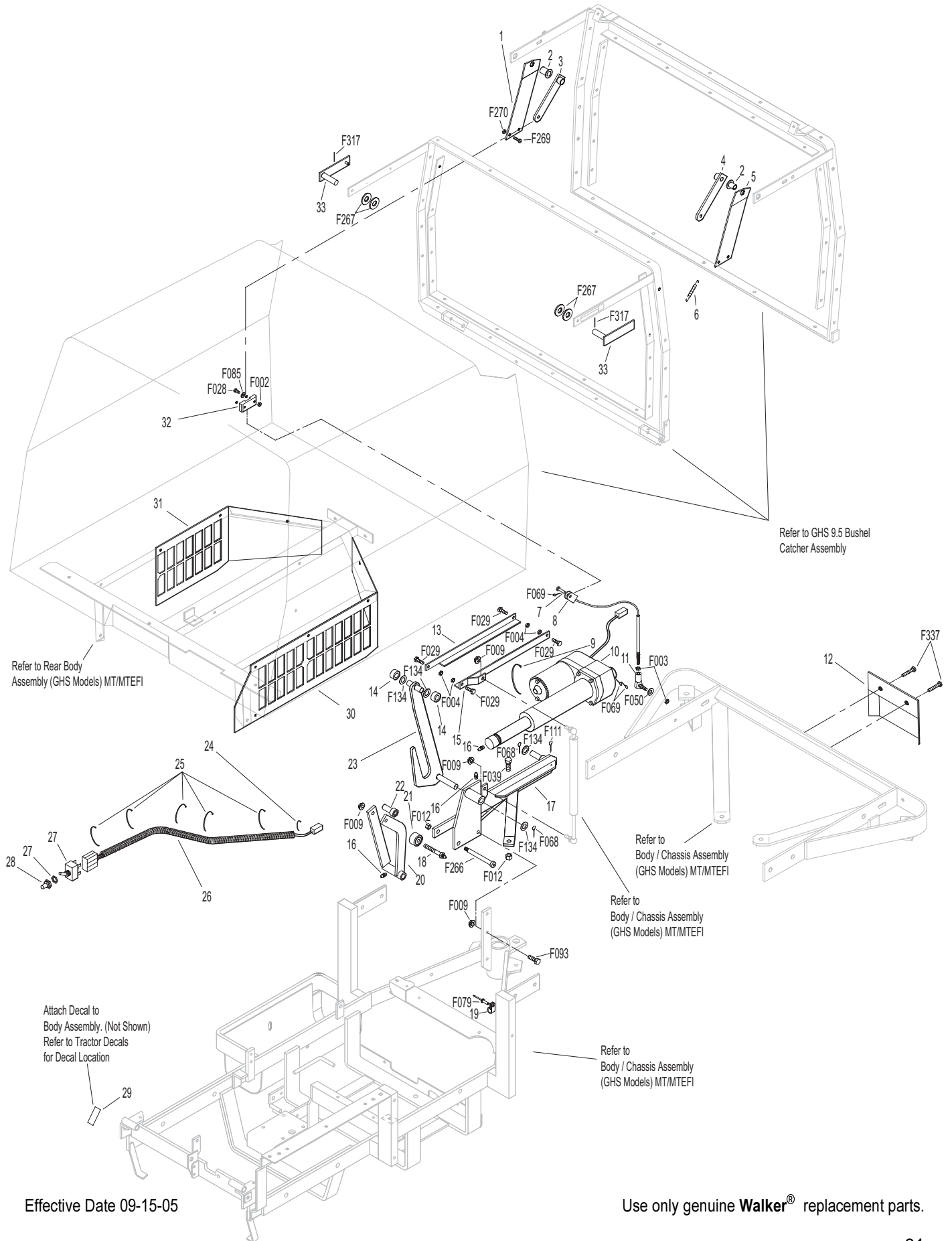

Effective Date 09-15-05

Use only genuine Walker® replacement parts.

# HI-DUMP KIT

ITEM NO.	PART NO.	DESCRIPTION	NO. REQ'D	ITEM NO.	PART NO.	DESCRIPTION	NO. REQ'D
<b>Hi-Dump Kit</b>				45	8404-3	Body Latch Hook/Hi-Dump	1
1	7613	Door Actuator/7.0/9.5	2	46	8400-2	Rear Pivot/RH (Includes Items # 20 & 28)	1
2	7612-2	Door Actuator Arm/RH	1	47	8402-7	Control Lift Rod	2
3	7612-1	Door Actuator Arm/LH	1	48	5214-9	Ball Joint (7/16-20LH) Hi Strength	4
4	7620-6	Cable Guide	2	<b>Fasteners</b>			
5	7523-2	Clevis Pin W/Hole (1/4 x 5/8)	2	F002	10-24 Keps Nut		8
6	7623-2	Power Dump Cable/9.5	2	F003	1/4-28 Hex Nut		2
7	5552	Ball Joint (1/4-28)	2	F004	1/4-20 Keps Nut		4
8	8402-3	Backup Plate	1	F009	5/16-18 Whiz Locknut		15
9	7628-1	Channel Angle/RH	1	F012	3/8-16 Keps Nut		8
10	8404-4	Channel Angle/Hi-Dump/LH	1	F013	3/8-16 Whiz Locknut		4
11	7146	13mm Ball Stud	2	F016	1/2-13 Self-Locking Nut		2
12	7145	Gas Spring Assembly (Includes Items # 11 & 13)	1	F025	10-24 x 3/8 PPHMS		1
13	7147	Spring Clip	2	F028	10-24 x 3/4 PPHMS		4
14	5841	Retainer Washer (3/8 x 1-1/4)	4	F034	5/16-18 x 3/4 Hex Bolt		5
15	8845	Rubber Bumper (30mm OD x 40mm) 5/16-18 Female	3	F035	5/16-18 x 1-1/4 Hex Bolt		2
16	8404-6	Clevis Pin (1/2 x 1-1/2)	1	F037	10-24 x 5/8 PTH Screw		2
17	8402-6	Catcher Pivot Plate, Hi-Dump	2	F038	3/8-16 x 1 Hex Bolt		3
18	7620-9	Roller Wheel	2	F039	3/8-16 x 1-1/4 Hex Bolt		4
19	8402-2	Catcher Pivot Arm (Includes Item # 20)	1	F040	3/8-16 x 1-1/2 Hex Bolt		4
20	5830	Grease Fitting	5	F048	1/2 SAE Washer		1
21	8404-5	Clevis Pin (1/2 x 1-1/4)	1	F049	5/16 SAE Washer		2
22	8402-4	Upper Cylinder Mount Arm	1	F050	1/4 SAE Washer		2
23	8402-1	Catcher Frame/Hi-Dump (Includes Item # 20)	1	F051	3/8 SAE Washer		2
24	7845	Rubber Bumper (1.375 x .63)	2	F068	1/8 x 1 Cotter Pin		1
25	8401-4	Upper Pivot Shaft	1	F069	3/32 x 1/2 Cotter Pin		2
26	8401-5	Pivot Arm (Includes Item # 27)	1	F085	3/16 Rivet Backup Washer		4
27	8401-9	Decal, Safety Lockout Arm	1	F106	3/8-16 x 5/8 Hex Bolt		2
28	5683	Pivot Bearing	2	F134	AN960816L Washer		2
29	8401-1	Torsion Spring (1-1/2)	1	F208	5/16-18 x 2-1/4 Hex Bolt		5
30	8401-6	Spring Bushing	1	F267	1/2 x 1 x 1/16 Washer		4
31	8401-3	Safety Lockout Arm	1	F385	1/4 x 1-1/4 Roll Pin		3
32	8401-2	Safety Lockout Spring	1	F395	1/4-20 x 2-1/4 FHA Screw SS		4
33	8400-3	Rear Pivot/LH (Includes Items # 20 & 28)	1	F396	10-24 x 1-1/4 Hex Bolt		2
34	5214-8	Ball Joint (7/16-20) Hi Strength	2	F398	1/4-20 x 2 Hex Bolt		2*
35	8400-8	Decal, Hi-Dump	1	F399	1/2-13 x 3-1/4 Hex Bolt		2
36	8404-7	Adapter Bracket / MTL	1*	F405	3/8-16x1-1/2 FHA Screw SS		1
37	8430	Body Chute, Hi-Dump	1	F408	7/16-20 Jam Nut		2
	8430-1	Body Chute, Hi-Dump, 10.5"	1**	F409	7/16-20 Hex Nut/Left Hand		2
38	8400-10	Auxiliary Power Terminal Plate (Includes Item # 39)	1	* Model MTL Only			
39	8400-7	Decal, Electrical Jumper Warning	1	** Item used when tractor is equipped with 10.5" GHS Blower.			
40	8400-5	Switch Mount	1				
41	8400-9	Decal, Hi-Dump Operation	1				
42	8400-4	Switch Cover (Includes Item # 41)	1				
43	8400-1	Bumper/Hi-Dump Mount (Includes Item # 35)	1				
44	7854	Plastic Tip/Red	1				

Use only genuine **Walker**<sup>®</sup> replacement parts.

Effective Date 09-15-05



# HI-DUMP KIT

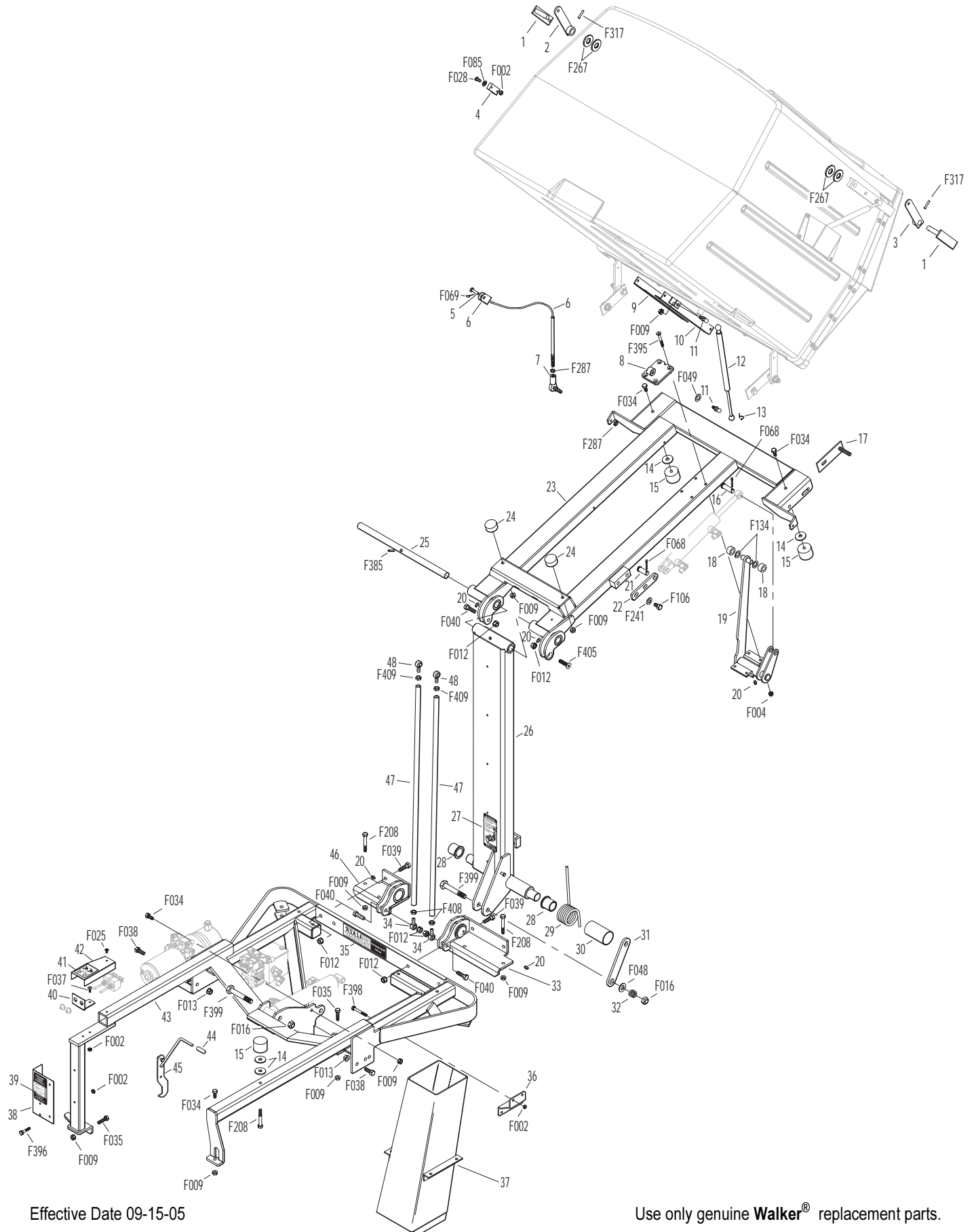

Effective Date 09-15-05

Use only genuine Walker® replacement parts.

# HI-DUMP KIT - HYDRAULIC

ITEM NO.	PART NO.	DESCRIPTION	NO. REQ'D	ITEM NO.	PART NO.	DESCRIPTION	NO. REQ'D
<b>Hi-Dump Kit</b>				<b>Component Replacement Part</b>			
1	5833	Cable Clamp (1/4)	3	29	8403-11	Counterbalance Valve	1
2	8440-1	Catcher Adapter Harness	1	30	8403-8	Directional Valve	2
3	8404	Dump Cylinder	1	31	8403-9	Coil W/Connectors	2
4	8403-7	90° Fitting	12	32	8403-10	Breather W/Riser	1
5	5975-3	Cable Tie (50# x 7")	5	33	8403-1	Reservoir/Power Unit	1
6	8403-6	Hydraulic Hose, Catcher Box Dump (73.5)	1	<b>Fasteners</b>			
7	8403-5	Hydraulic Hose, Catcher Box Dump (67.5)	1				
8	5835	Cable Clamp (3/4)	6	F002	10-24 Keps Nut		8
9	8403-3	Hydraulic Hose, Lift/Rear (11.5)	1	F004	1/4-20 Keps Nut		2
10	8404-1	Lift Cylinder	1	F025	10-24 x 3/8 PPHMS		13
11	8403-2	Hydraulic Hose, Lift/Front (16)	2	F027	10-24 x 5/8 PPHMS		5
12	5975-7	Cable Tie (50# x 11")	2	F106	3/8-16 x 5/8 Hex Bolt		2
13	8404-2	Hydraulic Valve Box	1	F232	10-32 Keps Nut		2
14	8403-4	Hydraulic Hose, Valve to Pump (17-1/2)	2	F397	1/4-20 x 3-1/4 Hex Bolt		2
15	5975-1	Cable Tie (18# x 3-3/4")	9				
16	8403	Hydraulic Power Unit	1				
17	8440-2	Switch Harness	1				
18	5832	Cable Clamp (1/2)	1				
19	8401-7	Junction Block 10-32	2				
20	7941	Circuit Breaker 40 Amp (Auto Reset/Sealed)	1				
21	8404-9	Plastic Cover/Black	1				
22	8404-8	Plastic Cover/Red	1				
23	6623-1	Switch Boot	2				
24	6623	Toggle Switch	2				
25	8440-3	Jumper Wire	1				
26	8440	Wire Harness/Hi-Dump	1				
27	6941-5	Relay Switch 60 Amp (NC)	2				
28	7833	Cable Clamp (7/8 x 1/4)	1				

Use only genuine **Walker**<sup>®</sup> replacement parts.

Effective Date 09-15-05

# HI-DUMP KIT - HYDRAULIC

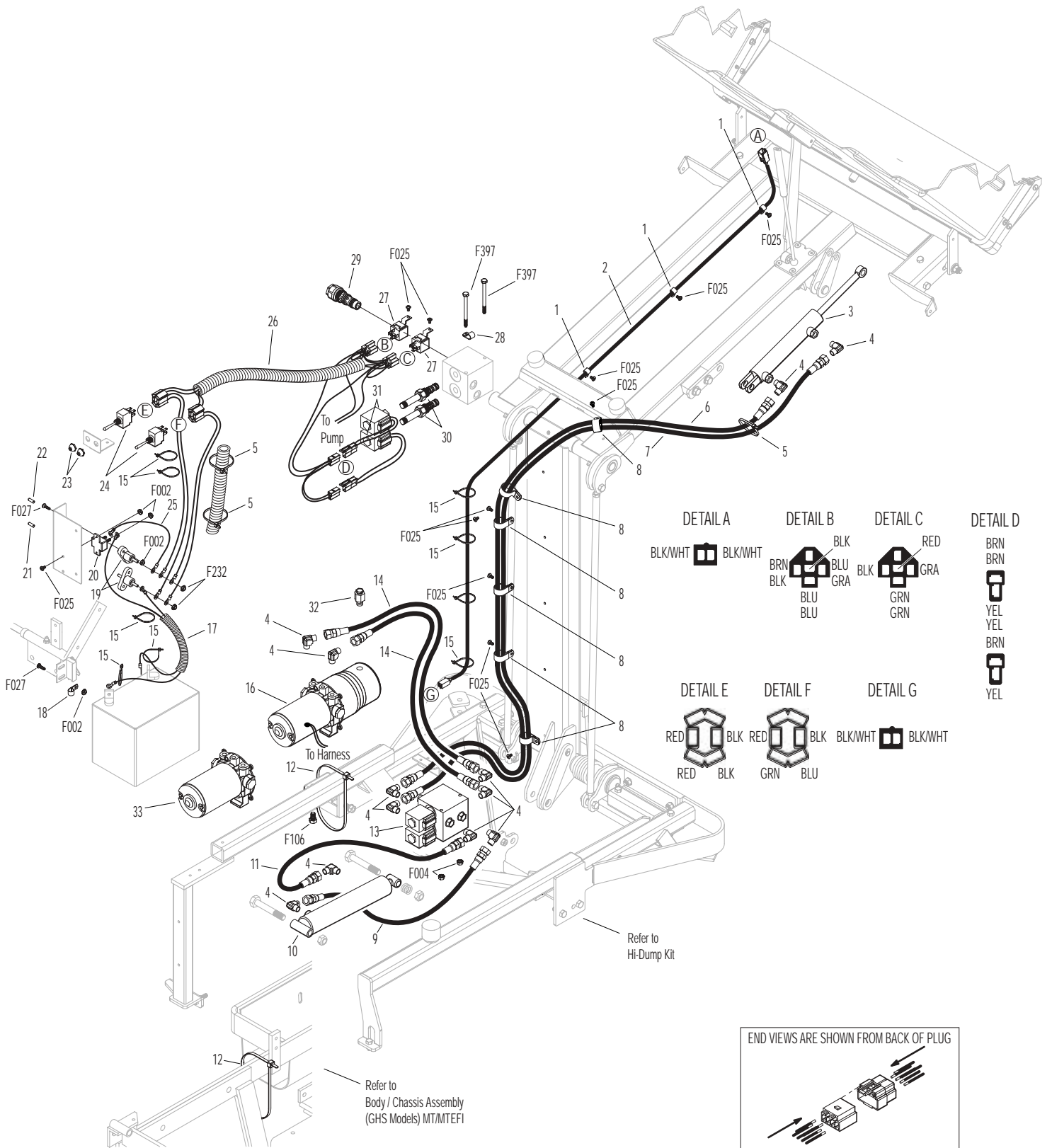

# NO CATCH DEFLECTOR KIT / TAIL WEIGHT KIT / SPREAD TAIL WHEEL AXLE KIT

ITEM NO.	PART NO.	DESCRIPTION	NO. REQ'D
----------	----------	-------------	-----------

**Kit 7500 (7.0 Bushel) No Catch Deflector Option / Kit**  
Includes Items # 1-5, fasteners and instructions.

**Kit 8500 (9.5 Bushel) No Catch Deflector Option / Kit**  
Includes Items # 1-5, fasteners and instructions.

No-Catch Deflector kits may be ordered as a dealer-installed option. Contact your Walker dealer.

1	7500	No-Catch Deflector Kit (7.0)	1
	8500	No-Catch Deflector Kit (9.5)	1
2	8500-5	Side Bracket	2
3	8787-2	Knob (1/4-20) Threaded Insert	1
4	8500-6	Spacer Lug	1
5	8500-8	Decal, No Catch Deflector	1

**Kit 7647 Tail Weight Option / Kit**  
Includes Items # 6, F012, F039 and instructions. May be ordered as a dealer-installed option. Contact your Walker dealer.

6	7647-9	Tail Weight Strap	2
7	7647-5	Tail Weight Plate, 10-lb	*

**Kit 7420-3 Spread Axle Kit/Less Wheels**  
Includes Items # 8-21, fasteners listed & instructions. May be ordered as a dealer-installed option. Contact your Walker dealer.

8	7420-6	Washer (2-1/2)	1
9	7420-5	Mount, Spread Axle	1
10	8769-8	Dust Cap, Deck Caster	2
11	8769-6	Bearing Cone (1" ID)	4
12	8769-5	Bearing Cup	4
13	7420-4	Fork Mount Tube (Includes Item # 12)	1
14	8769-7	Seal	2
15	7420-2	Tail Fork, Spread Axle	2
16	8039	Nut, Tail Wheel Axle	2
17	8038-1	Spacer, Tail Wheel Axle	2
18	7038	Tail Wheel Axle (3/4 x 5-9/16)	2
19	5683	Pivot Bearing	2
20	5830	Grease Fitting	3
21	7420-7	Pivot Shaft (1 x 5-1/4)	1

ITEM NO.	PART NO.	DESCRIPTION	NO. REQ'D
----------	----------	-------------	-----------

## Fasteners

F002	10-24 Keps Nut	4
F012	3/8-16 Keps Nut	6
F016	1/2-13 Self-Locking Nut	1
F030	1/4-20 x 1/2 PPH Bolt	1
F038	3/8-16 x 1 Hex Bolt	2
F039	3/8-16 x 1-1/4 Hex Bolt	6
F128	10-24 x 3/8 PTHMS	4
F140	7/16-14 x 1 Hex Bolt	4
F175	1/2 Split Lock Washer	2**
F205	5/16-18 x 1/4 Set Screw	2
F218	7/16 Split Lock Washer	4
F278	3/8 Split Lock Washer	2
F285	1/2-13 x 1-1/2 Hex Bolt	2**
F333	1/4-20 x 3/4 PTHMS	1
F344	3/4-16 Slotted Hex Nut	2
F347	3/4 SAE Washer	2
F348	1/8 x 1-1/2 Cotter Pin	2
F377	1/2-13 x 5 Hex Bolt	1

\* Optional

\*\* Use with optional 10-lb plate.

**NOTE:** If equipped, existing dual tail wheels and tires can be reused with kit 7420-3. Order Kit # 7420-20 for two wheels and tires if tractor is equipped with a single wide tail wheel.

# NO CATCH DEFLECTOR KIT / TAIL WEIGHT KIT / SPREAD TAIL WHEEL AXLE KIT

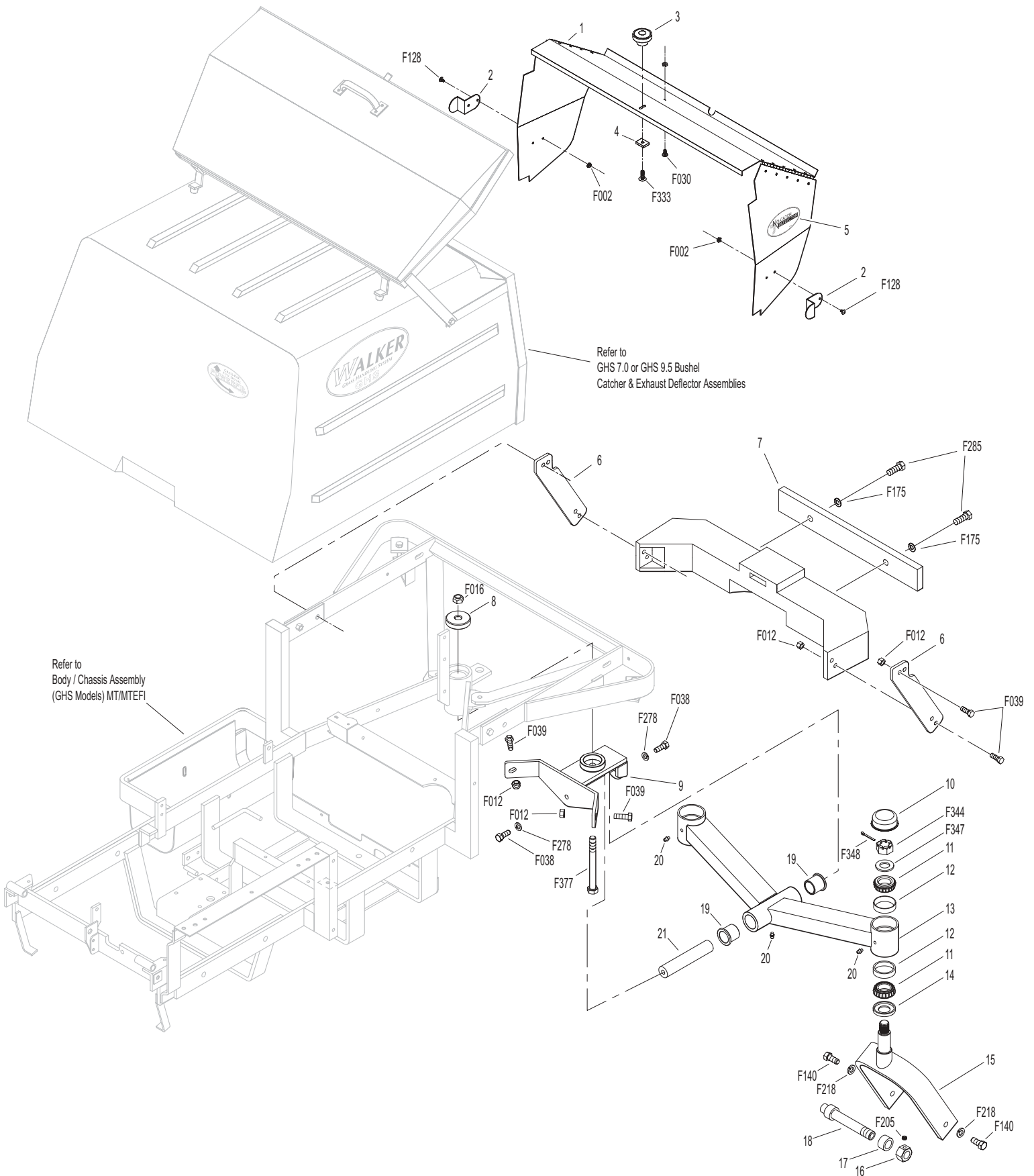

Effective Date 09-15-05

Use only genuine Walker® replacement parts.

# TAIL WHEEL LOCK KIT

ITEM NO.	PART NO.	DESCRIPTION	NO. REQ'D	ITEM NO.	PART NO.	DESCRIPTION	NO. REQ'D
<b>Kit 8540 Tail Wheel Lock Option / Kit</b> Includes Items # 1-28, fasteners listed & instructions. May be ordered as a dealer-installed option. Contact your Walker dealer.				<b>Fasteners</b>			
1	5995-2	Switch Boot	1	F002		10-24 Keps Nut	4
2	8547	Switch Mount	1	F003		1/4-28 Hex Nut	1
3	8555	Decal, Tail Lock Switch	1	F004		1/4-20 Keps Nut	3
4	5995	Toggle Switch (Off-On)	1	F012		3/8-16 Keps Nut	2
5	7942-4	Single Connector, Male	2*	F026		10-24 x 1/2 PPHMS	2
6	5940-4	16-14 GA Spg. Loaded Term., Female	5*	F029		1/4-20 x 1/2 Hex Bolt	2
7	5977-2	Grommet, Cut (1/8 x 3/8)	1	F038		3/8-16 x 1 Hex Bolt	2
8	5975-3	Cable Tie (50# x 7")	4	F050		1/4 SAE Washer	2
9	8550	Wire Harness	1	F134		AN960816L Washer	1
10	5975-1	Cable Tie (18# x 3-3/4")	3	F179		1/4-20 x 1 Hex Bolt	2
11	8553	Splice Tap (18-14 GA)	1	F190		#10 Internal Star Lock Washer	1
12	8543	Solenoid Mount	1	F198		.250 x .625 x .040 Washer, SS	1
13	5830-3	Grease Fitting (45 Degree)	1	F298		3/8-24 Jam Nut	1
14	8551	Ground Wire	1	F299		10-24 x 1 PPHMS	2
15	8546	Solenoid, Control Module	1	F300		1.015 x 1.500 x .031 Washer	1
16	5996	1/4 16-14 GA QKS Term., Female	5*	F350		1/4-20 LP Nylock	1
17	8552	Connector Plug & Wire Assy	1	* Service Part Only			
18	8544	Clevis, Wheel Lockout (9/16)	1	<b>NOTE:</b> Refer to <b>ELECTRICAL CONNECTORS</b> , Page 64 for identification of all Electrical Wiring Service Parts.			
19	5551-1	Pivot Bearing	2*				
	8545-1	Pivot Bearing Assembly (Includes Items # 19, 20, F179 & F350)					
20	8544-1	Bearing Spacer (1/4 ID x 9/16)	1*				
21	8542	Tail Wheel Fork, Locking	1				
22	8944	3-Way Locking Connector, Male	1*				
23	8944-1	3-Way Locking Connector, Female	1*				
24	5940-5	16-14 GA Spg. Loaded Term., Male	1*				
25	5996-13	16-14 GA Ring Term., #10	1*				
26	7929	Actuating Solenoid	1				
27	8549	Sleeve, Delrin	1				
28	8541	Plunger Rod	1				
	8554	Solenoid & Mount Assembly (Includes Items # 12-15, 17-20, 26-28, F002, F003, F004, F029, F050, F179, F190, F198, F298, F299 & F350)	*				

# TAIL WHEEL LOCK KIT

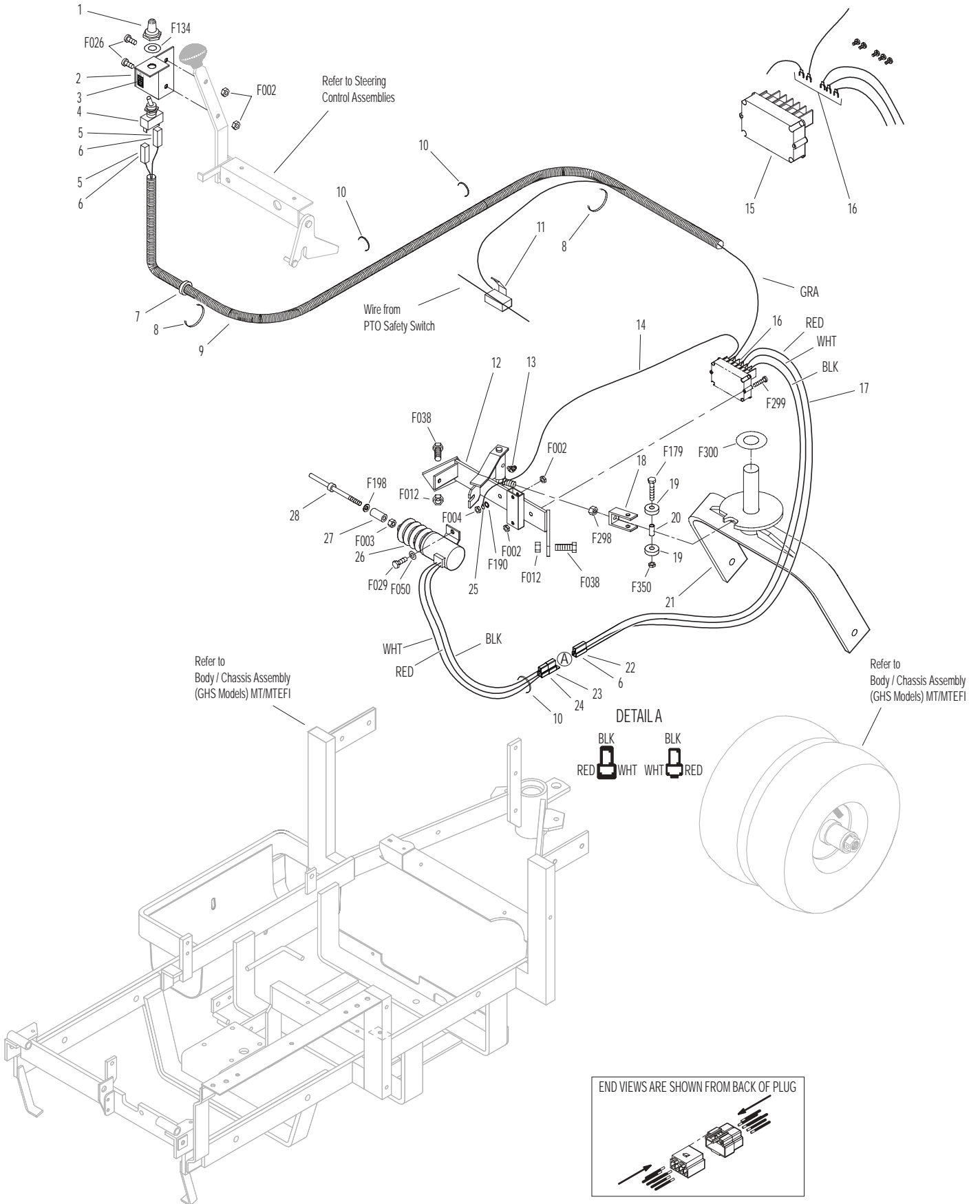

Effective Date 09-15-05

Use only genuine Walker® replacement parts.

# WIDE TAIL WHEEL / ALL-TERRAIN TIRE KIT & TIRE CHAIN SET

ITEM NO.	PART NO.	DESCRIPTION	NO. REQ'D
----------	----------	-------------	-----------

**Kit 8049 Wide Tail Wheel Option / Kit**  
Includes Items # 1, 3 and instructions. May be ordered as a dealer-installed option. Contact your Walker dealer.

1	8037-1	Seal, Outer (1-3/4 x 1-1/8)	2
2	8048	Wide Tail Wheel Axle	1
3	8045	Wide Tail Wheel & Tire (13 x 8.00-6)	1
	8045-1	Wide Tire (13 x 8.00-6)	*
	8047	Wheel & Hub (6 x 7)	*

**AT8072 All-Terrain Tire Option**

Includes Item # 4 and instructions. May be ordered as a dealer-installed option. Contact your Walker dealer.

4	8070-6	AT Wheel & Tire RH/LH (18 x 11-10)	2
	8070-7	All Terrain Tire Non-Dirc (18 x 11-10)	*
	8070-8	AT/LP Wheel (10 x 8.5)	*
	8075-2	AT/LP Tire Tube (18 x 11-10)	*
5	8070-31	Wheel Spacer Plate (1/2)	2

ITEM NO.	PART NO.	DESCRIPTION	NO. REQ'D
----------	----------	-------------	-----------

**Kit LP8075 Low Profile Tire Option / Kit**  
Includes Item # 6 and instructions. May be ordered as a factory-installed option, or as a kit for dealer installation. Contact your Walker dealer.

6	8075	LP Wheel & Tire (18 x 10.5-10)	2
	8075-1	LP Tire (18 x 10.5-10)	*
	8070-8	AT/LP Wheel (10 x 8.5)	*
	8075-2	AT/LP Tire Tube (18 x 11-10)	*

**Optional Tire Chain Set**

7	5675-3	Tire Chain Set (18 x 9.50-8)	1
---	--------	------------------------------	---

\* Service Part Only



# WIDE TAIL WHEEL / ALL-TERRAIN TIRE KIT & TIRE CHAIN SET

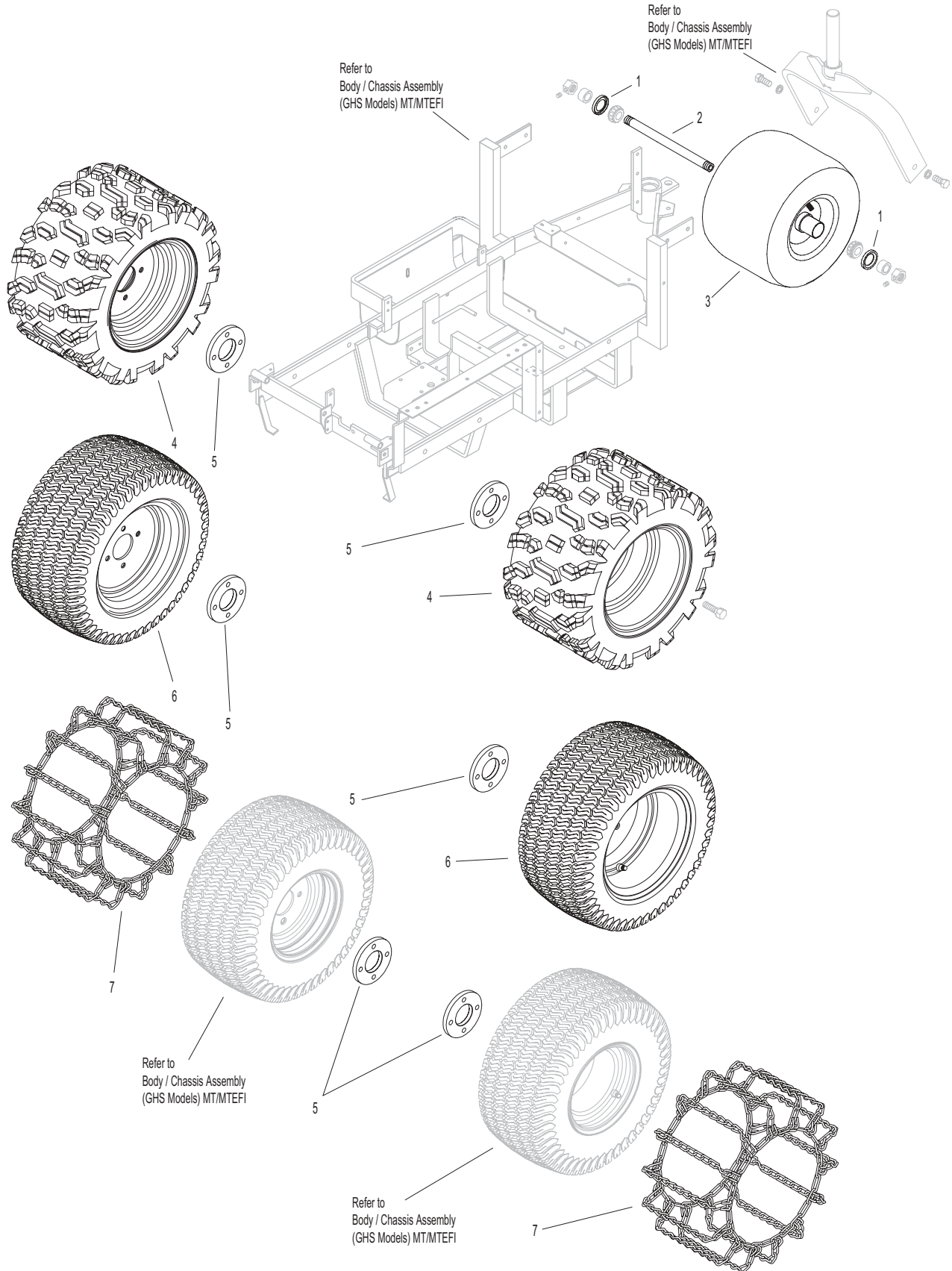

# LUBRICATION POINTS

ITEM NO.	LOCATION	LUBRICATION TYPE	NO. PLACES	ITEM NO.	LOCATION	LUBRICATION TYPE	NO. PLACES
<b>Lubrication Points</b>				25	Brake Actuator Rod and Brake Band Pivot Pins (Clevis)	Oil	3
1	Deck Caster Wheel Fork Pivot	Grease	2	26	Brake Actuator Pivot	Grease	1
2	Deck Caster Wheel Bearing	Grease	2	27	Catcher Hinge Point	Oil	2
3	Tee Gearbox, Deck	Oil*	1	28	Rear Wheel Bearings	Grease	2
4	Blade Drive Gearbox	Oil*	2	29	Engine Oil	Oil***	1
5	Universal Joint Shaft Assembly	Grease**	1	30	Choke Control Cable Ends (Models MT and MTL only)	Oil	2
6	Pivot Assembly, Tilt-Up Deck	Grease	4	31	Belt Tightener Pivot, Blower Drive (GHS Model Only)	Grease	1
7	Deck Support Arm Socket	Grease	2	32	Belt Tightener Pivot, Ground Drive	Grease	1
8	Body Hinge Point	Oil	2	33	PTO Gearbox Dipstick	Oil***	1
9	FSC Actuator Rod Pivot Pins	Oil	2	34	Hydrostatic Drive	Oil***	2
10	FSC Lever Pivot	Grease	1	35	Choke Control Pivot (Models MT, MTL and MTLEFI only)	Oil	1
11	FSC Lever Fork (Grease Slide Area)	Grease	1	36	Throttle Control Pivot	Oil	1
12	(FSC) Friction Body Pivot	Grease	1				
13	Steering Lever Pivot	Grease	4				
14	Deck Support Arm Pivot	Grease	2				
15	Deck-to-PTO Coupling (Grease Slide Area)	Grease	1				
16	Universal Joint Tube Assembly	Grease**	1				
17	Universal Joint Quick Connect Spline (Grease Slide Area)	Grease	1				
18	Parking Brake Lever	Grease	1				
19	Gear Axle	Oil***	2				
20	Belt Tightener Pivot, Jackshaft Drive	Grease	1				
21	Throttle Control Cable Ends	Oil	2				
22	Clutch Actuator Push Rod	Grease	2				
23	PTO Clutch Lever Pivot	Grease	1				
24	Belt Tightener Pivot, PTO Clutch	Grease	1				

\* Gearboxes are permanently lubricated and sealed requiring no scheduled lubrication. Oil level should be checked only when an oil leak is noted.

\*\* Grease every eight (8) hours.

\*\*\* Refer to MT **Owner's Manual** for procedure for checking and changing oil in Engine Crankcase, Hydrostatic Transmissions and Gear Axles.

**NOTE:** See Model MT **Owner's Manual** (P/N 8000-9) for proper lubrication intervals.

**NOTE:** DGHS42 Tilt-Up Deck is shown for reference. For other Deck Lubrication Points, Refer to Deck and Carrier Frame **Illustrated Parts Manual**.

# LUBRICATION POINTS

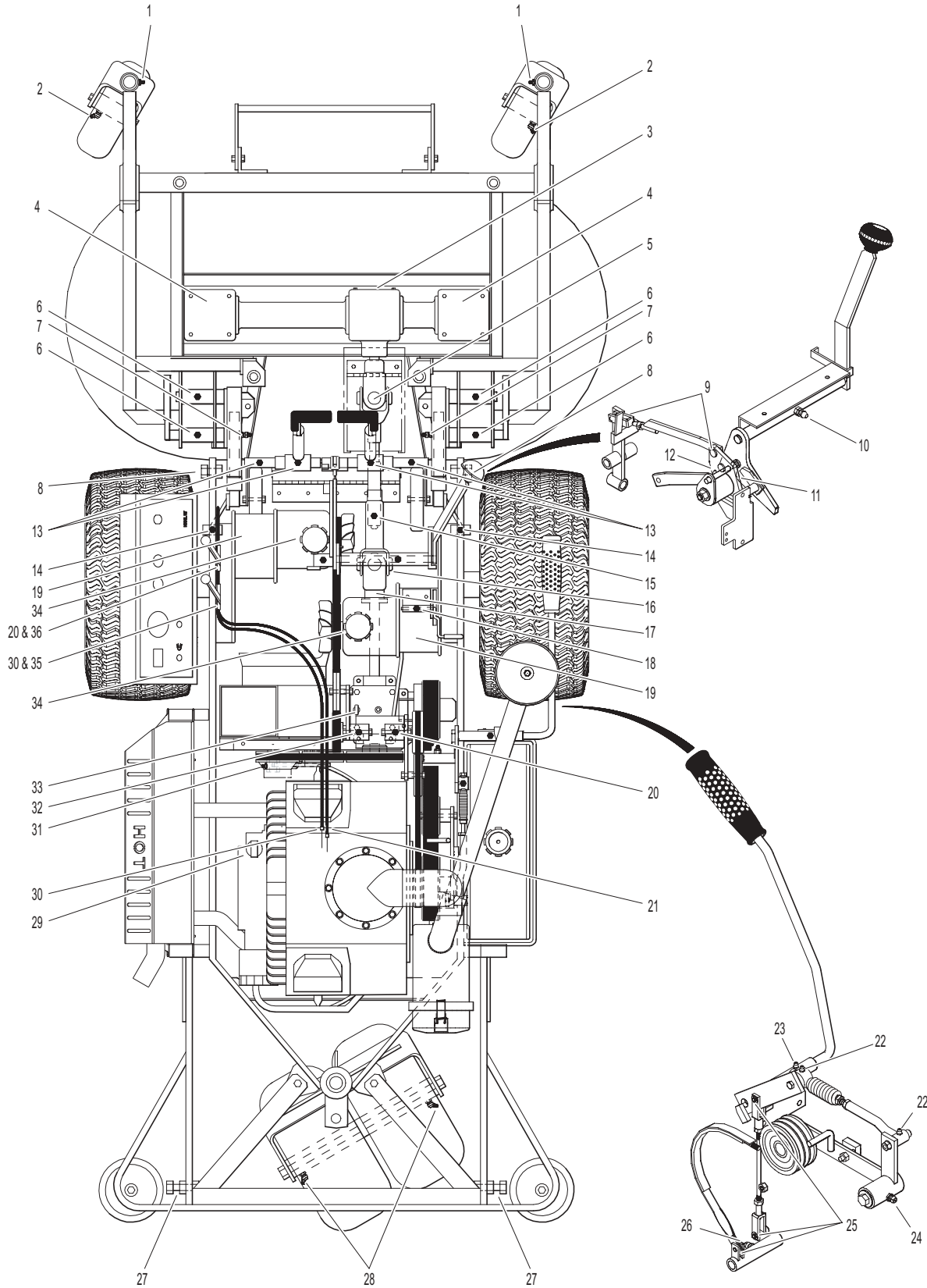

# WIRING SCHEMATIC (MT)

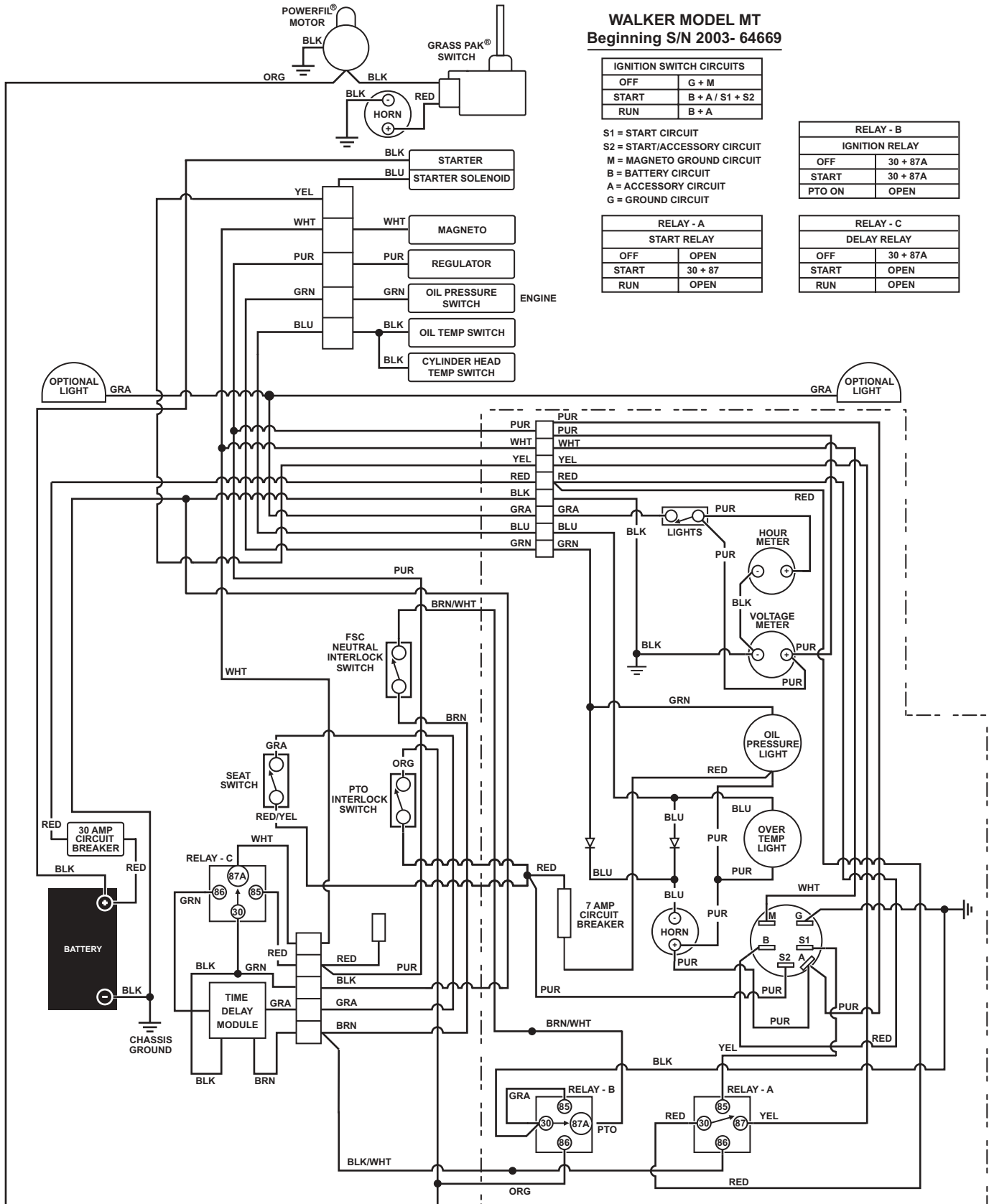

Use only genuine Walker® replacement parts.

Effective Date 09-15-05

# WIRING SCHEMATIC (MTL)

**WALKER MODEL MTL**  
Beginning S/N 2003-64669

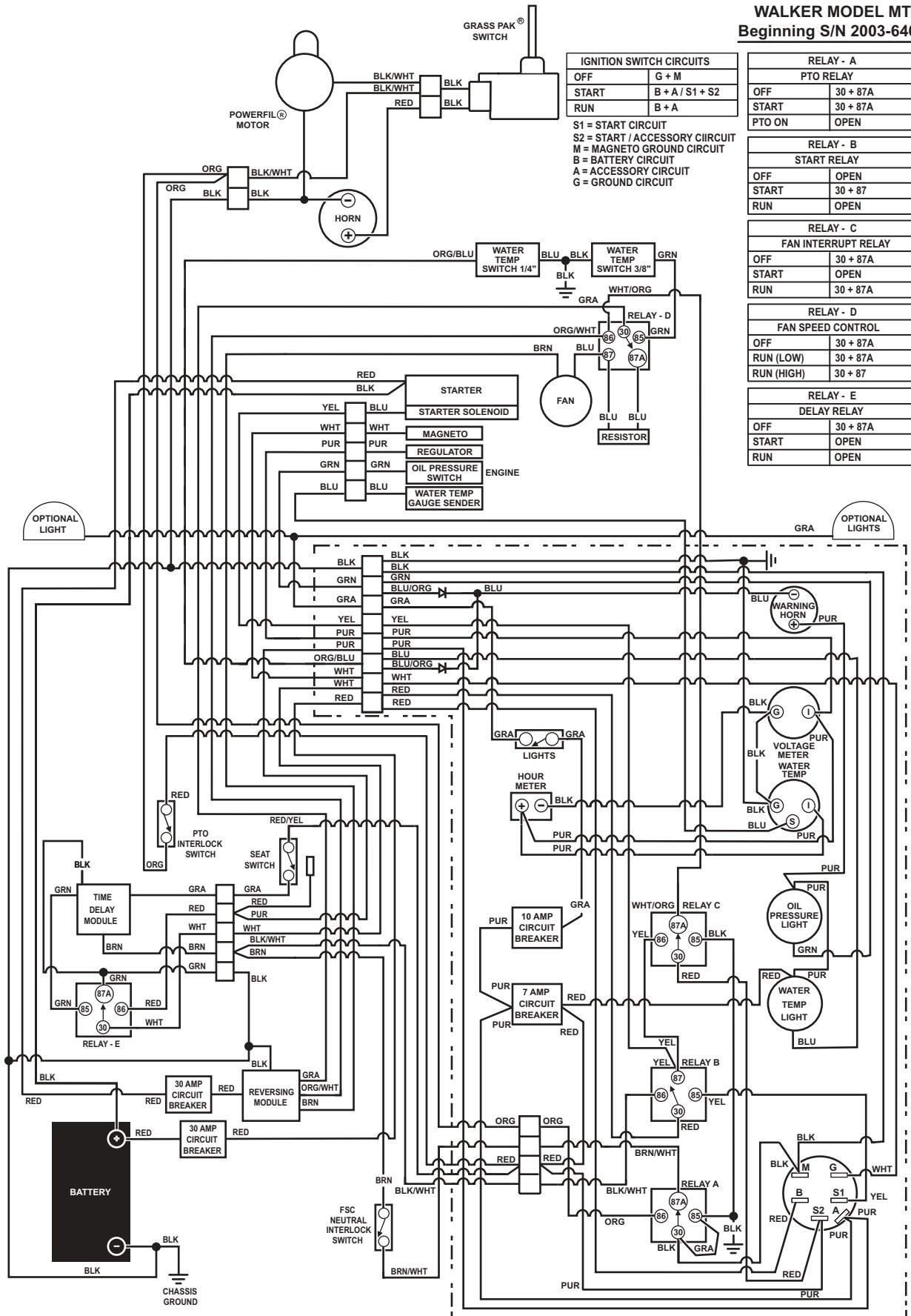

# WIRING SCHEMATIC (MTEFI)

## WALKER MODEL MT-EFI Beginning S/N 2003-64669

IGNITION SWITCH CIRCUITS	
OFF	G + M
START	B + A / S1 + S2
RUN	B + A

S1 = START CIRCUIT  
 S2 = START / ACCESSORY CIRCUIT  
 M = MAGNETO GROUND CIRCUIT  
 B = BATTERY CIRCUIT  
 A = ACCESSORY CIRCUIT  
 G = GROUND CIRCUIT  
 J1 = #1 FUEL INJECTOR  
 J2 = #2 FUEL INJECTOR  
 J3 = THROTTLE POSITION SENSOR  
 J4 = OIL TEMP SENSOR  
 J5 = OXYGEN SENSOR  
 J6 = REGULATOR / RECTIFIER  
 J8 = ENGINE GROUND  
 J10 = #1 IGNITION COIL  
 J11 = #2 IGNITION COIL  
 J12 = #1 IGNITION COIL  
 J13 = #2 IGNITION COIL  
 J14 = IGNITION COIL GROUND  
 J20 = SPEED PICK-UP SENSOR

RELAY - A IGNITION / FUEL RELAY	
OFF	OPEN
START	OPEN
PTO ON	30 + 87

RELAY - B DELAY RELAY	
OFF	30 + 87A
START	OPEN
RUN	OPEN

RELAY - C START / TIME DELAY RELAY	
OFF	30 + 87A
START	30 + 87A
RUN	OPEN

RELAY - D START / SOLENOID RELAY	
OFF	OPEN
RUN (LOW)	OPEN
RUN (HIGH)	30 + 87

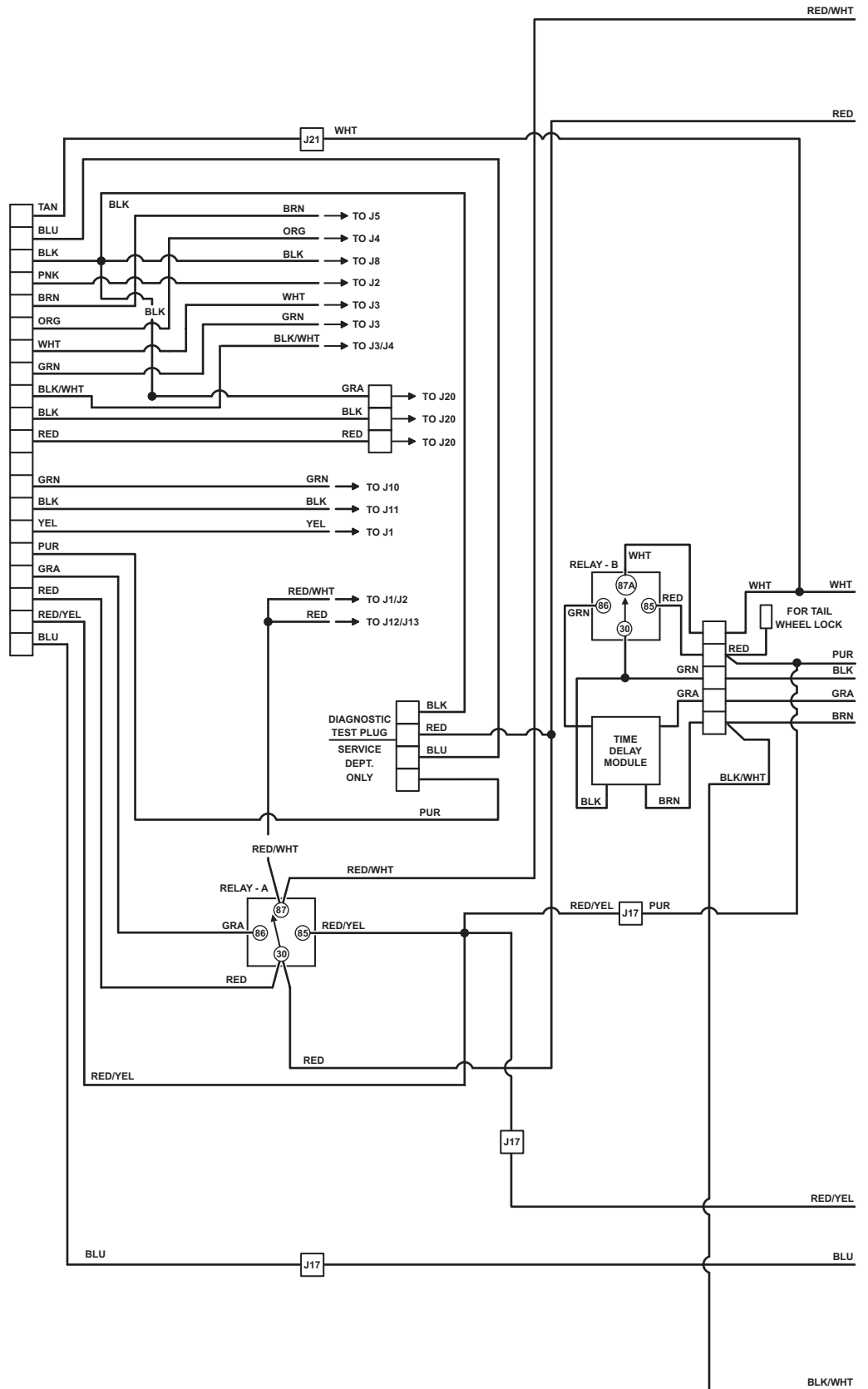

# WIRING SCHEMATIC (MTEFI)

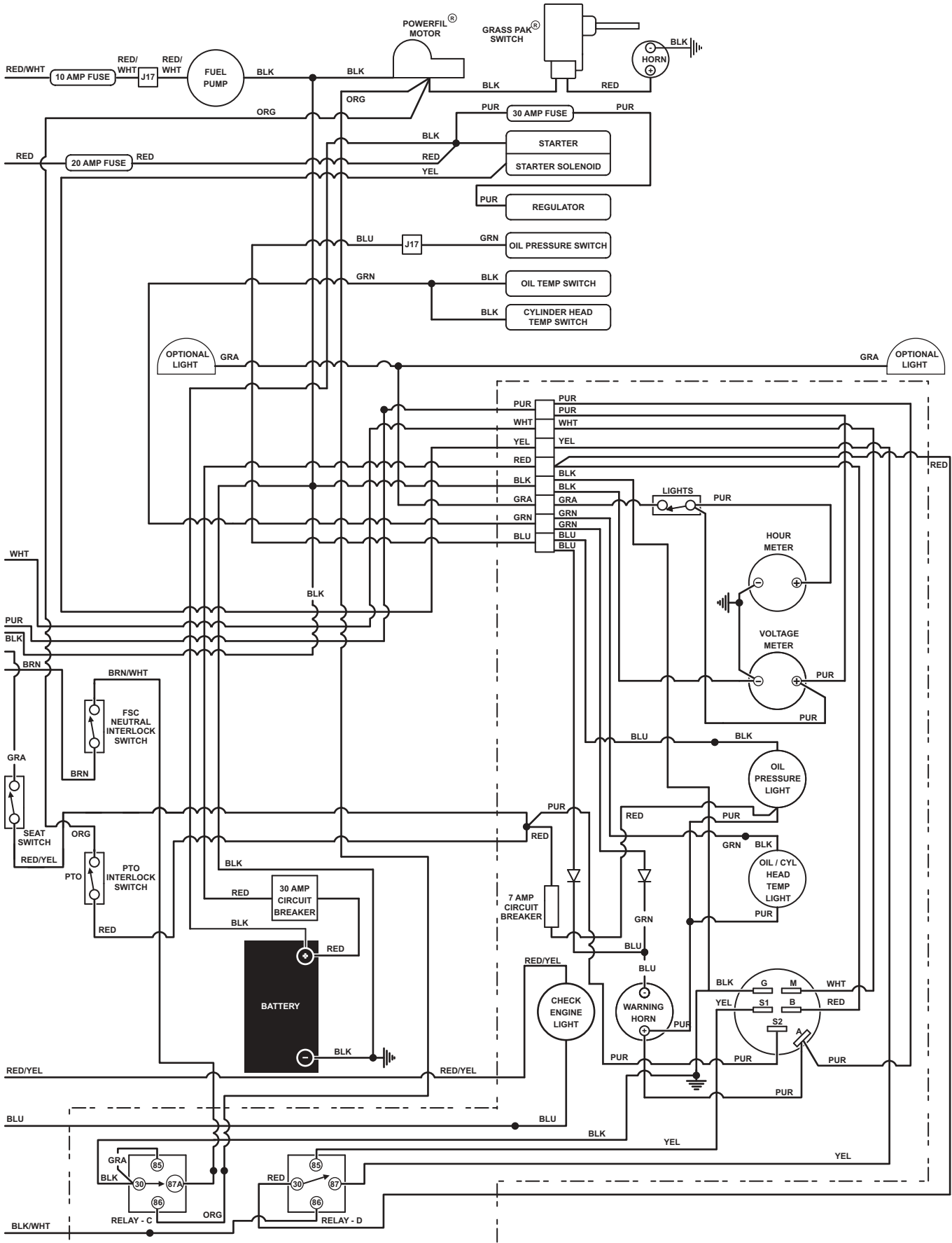

Effective Date 09-15-05

Use only genuine Walker® replacement parts.

# WIRING SCHEMATIC (MTLEFI)

## WALKER MODEL MTL-EFI Beginning S/N 2005-75988

- S1 = START CIRCUIT
- S2 = START / ACCESSORY CIRCUIT
- M = MAGNETO GROUND CIRCUIT
- B = BATTERY CIRCUIT
- A = ACCESSORY CIRCUIT
- G = GROUND CIRCUIT
- J1 = #1 FUEL INJECTOR
- J2 = #2 FUEL INJECTOR
- J3 = THROTTLE POSITION SENSOR
- J4 = OIL TEMP SENSOR
- J5 = OXYGEN SENSOR
- J6 = REGULATOR / RECTIFIER
- J8 = ENGINE GROUND
- J10 = #1 IGNITION COIL
- J11 = #2 IGNITION COIL
- J12 = #1 IGNITION COIL
- J13 = #2 IGNITION COIL
- J14 = IGNITION COIL GROUND
- J20 = SPEED PICK-UP SENSOR

RELAY - A	
PTO RELAY	
OFF	30 + 87A
START	30 + 87A
PTO ON	OPEN

RELAY - B	
START RELAY	
OFF	OPEN
START	30 + 87
RUN	OPEN

RELAY - C	
FAN INTERRUPT RELAY	
OFF	30 + 87A
START	OPEN
PTO ON	30 + 87A

RELAY - D	
FAN SPEED CONTROL	
OFF	30 + 87A
START	30 + 87A
PTO ON	30 + 87

RELAY - E	
DELAY RELAY	
OFF	30 + 87A
START	OPEN
PTO ON	OPEN

RELAY - F	
IGNITION / FUEL RELAY	
OFF	OPEN
START	OPEN
PTO ON	30 + 87

IGNITION SWITCH CIRCUITS	
OFF	G + M
START	B + A / S1 + S2
RUN	B + A

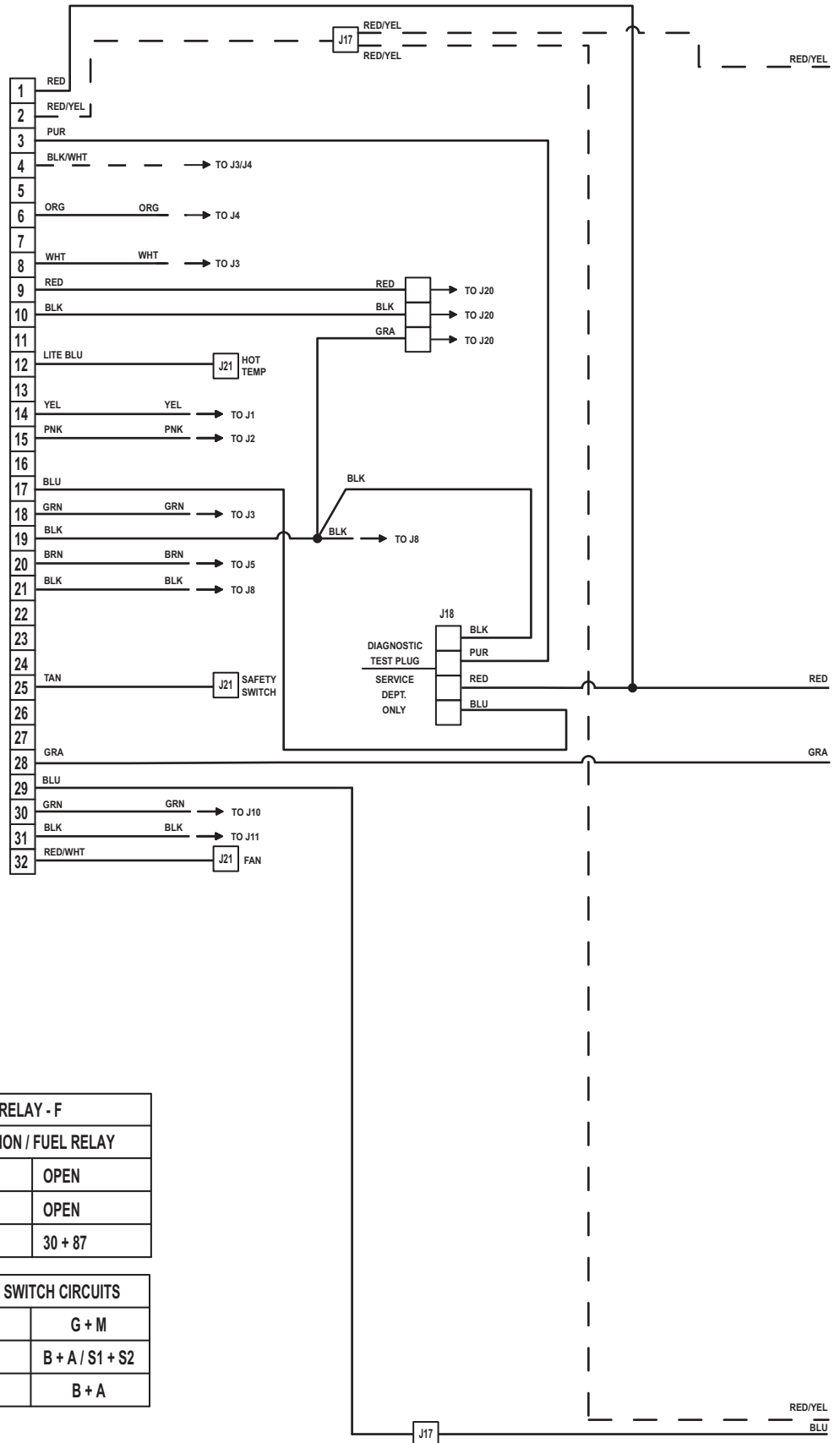

Use only genuine Walker® replacement parts.

Effective Date 09-15-05



# WIRING SCHEMATIC (MTLEFI)

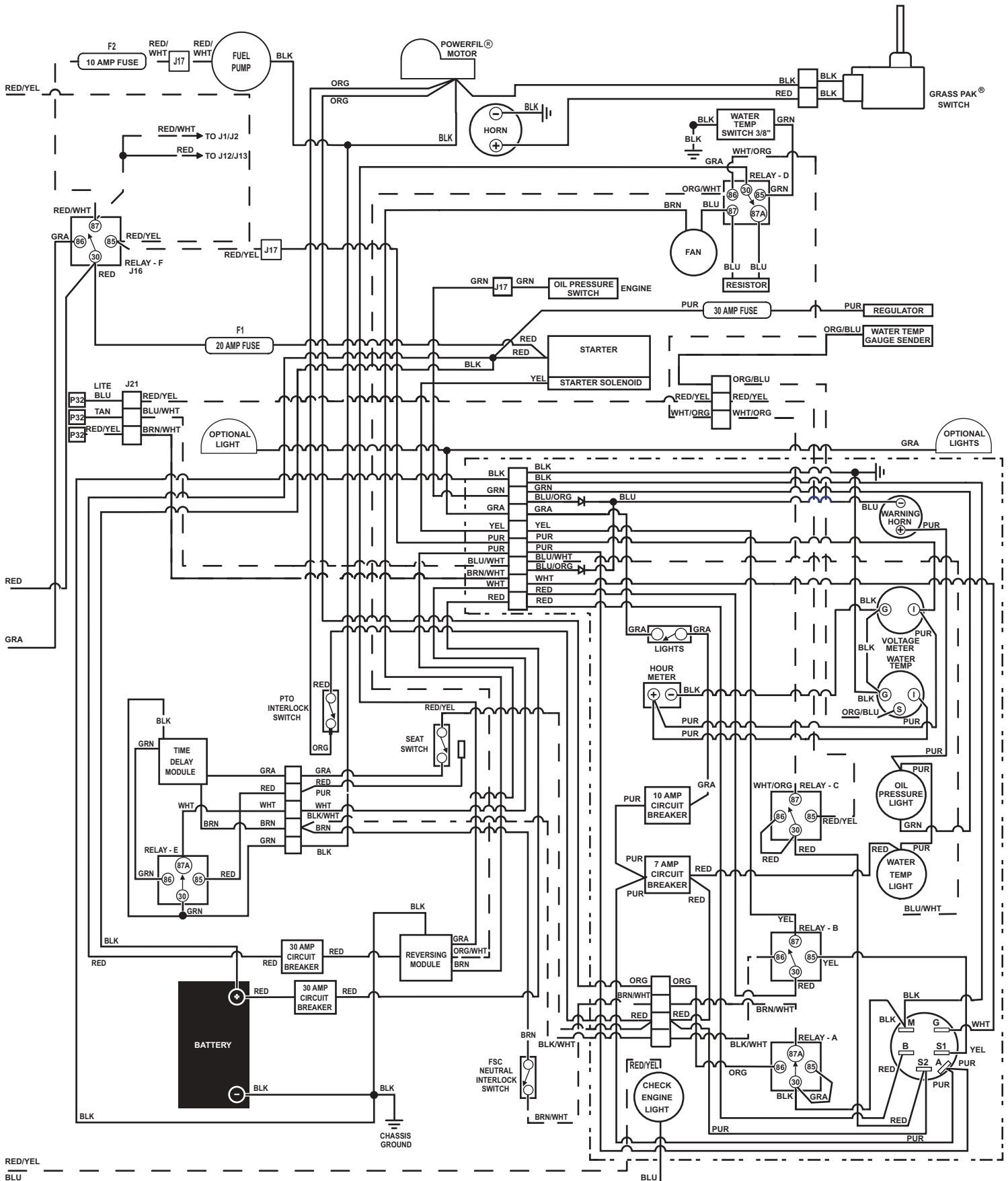

# WALKER HD8400 ELECTRICAL SCHEMATIC

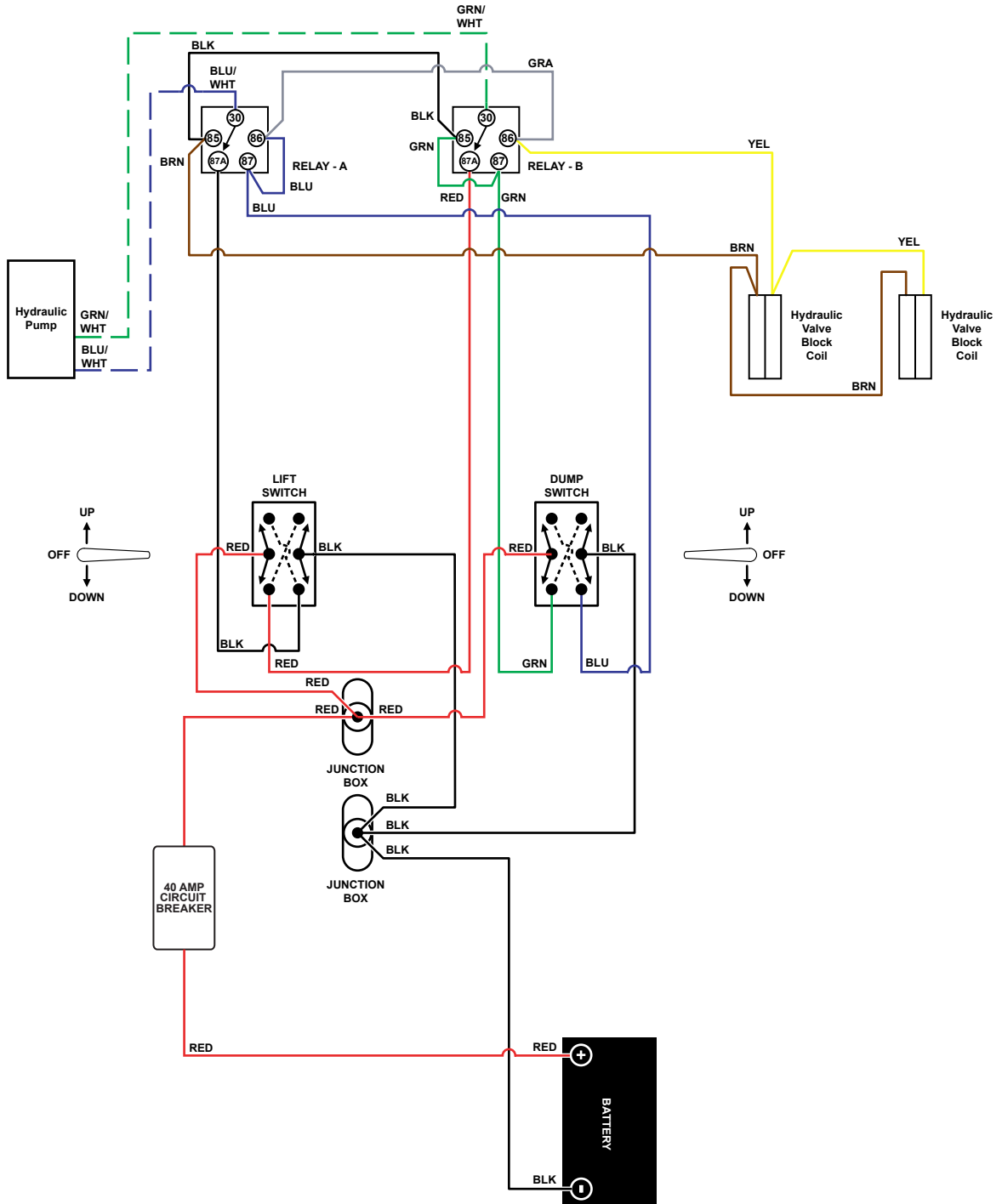

# OPERATOR'S NOTES

---

# LIMITED WARRANTY FOR WALKER COMMERCIAL RIDER MOWER

## 1. WHAT THIS WARRANTY COVERS, AND FOR HOW LONG:

Walker Manufacturing company will, at its option, repair or replace, without charge, any part covered by this warranty which is found to be defective in material and/or workmanship within one (1) year\* after date of sale to the original retail purchaser unless the product is used for rental purposes, in which case this warranty is limited to ninety (90) days. At Walker's request, customer will make the defective part available for inspection by Walker and/or return the defective part to Walker, transportation charges prepaid. All parts and components of the Walker Mower are covered by this warranty **except** the following components which are warranted separately by their respective manufacturers:

Kohler Engine  
Kubota Engine  
Kawasaki Engine  
Eaton Hydraulic Transmission  
Peerless Gearboxes  
Battery  
Tires

The available warranties covering these items are furnished with each mower. Walker does not assume any warranty obligation, liability or modification for these items, which are covered exclusively by the stated warranty of the respective manufacturers noted above.

\* An extended three (3) year warranty is offered on the Walker P/N 6200-9 Gear Axle Assembly.

## 2. WHAT THIS WARRANTY DOES NOT COVER:

- A. This warranty does not cover defects caused by depreciation or damage caused by normal wear, accidents, improper maintenance, improper use or abuse of the product, alterations, or failure to follow the instructions contained in the Owner's Manual for operation and maintenance.
- B. The customer shall pay any charges for making service calls and/or for transporting the mower to and from the place where the inspection and/or warranty work is performed.

## 3. HOW TO OBTAIN SERVICE UNDER THIS WARRANTY:

Warranty service can be arranged by contacting the dealer where you purchased the mower or by contacting Walker Manufacturing Company, 5925 East Harmony Road, Ft. Collins, CO 80528. Proof of the date of purchase may be required to verify warranty coverage.

## 4. WARRANTY LIMITATION:

- A. **THERE IS NO OTHER EXPRESS WARRANTY. ANY WARRANTY THAT MAY BE IMPLIED FROM THIS PURCHASE INCLUDING MERCHANTABILITY AND FITNESS FOR A PARTICULAR PURPOSE IS HEREBY LIMITED TO THE DURATION OF THIS WARRANTY AND TO THE EXTENT PERMITTED BY LAW ANY AND ALL IMPLIED WARRANTIES ARE EXCLUDED.** Some states do not allow limitations on how long an implied warranty lasts, so the above limitations may not apply to you.
- B. **WALKER WILL NOT BE LIABLE FOR ANY INCIDENTAL, CONSEQUENTIAL, OR SPECIAL DAMAGES AND/OR EXPENSES IN CONNECTION WITH THE PURCHASE OR USE OF THE MOWER.** Some states do not allow the exclusion or limitation of incidental or consequential damages, so the above limitation(s) or exclusion(s) may not apply to you.
- C. Only the warranty expressed in this limited warranty shall apply and no dealer, distributor, or individual is authorized to amend, modify, or extend this warranty in any way. Accordingly, additional statements such as dealer advertising or presentations, whether oral or written, do not constitute warranties by Walker, and should not be relied upon.
- D. This warranty gives you specific legal rights, and you may also have other rights which vary from state to state.

# WALKER MOWERS™

WALKER MFG. CO. • 5925 E. HARMONY ROAD, FORT COLLINS, CO 80528 • (970) 221-5614  
FORM NO. 091505      PRINTED IN USA      [www.walkermowers.com](http://www.walkermowers.com)      ©2005 WALKER MFG. CO