

# Walker Rider Lawnmowers

## ILLUSTRATED PARTS MANUAL

Model MC (18 HP)

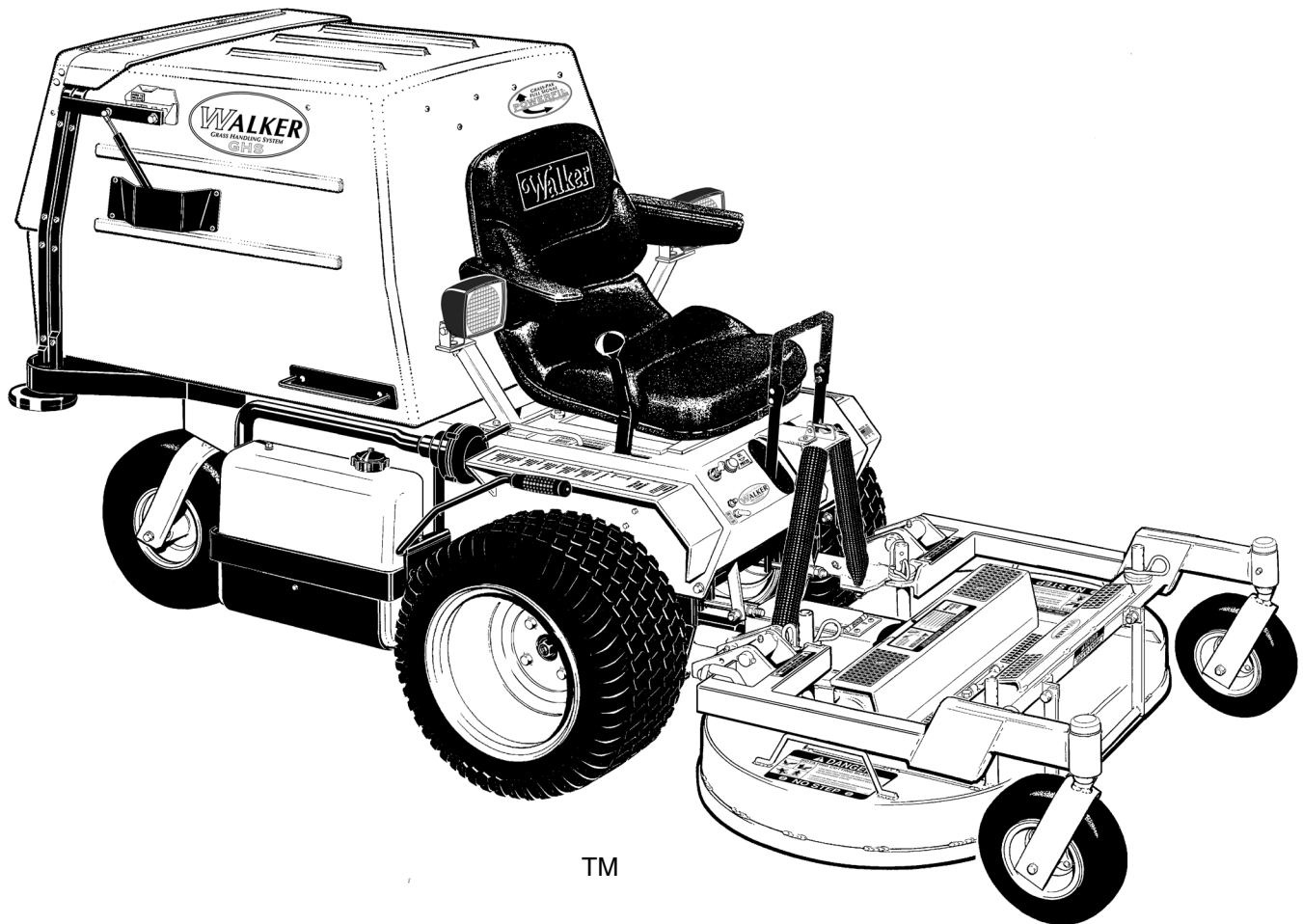

TM

CE

Effective Date:  
11-01-04

P/N 6000-10  
Price \$5.00

# KEY TO ABBREVIATIONS USED IN THIS MANUAL

<i>Abbreviation</i>	<i>What it Represents</i>
° (Dimension)	Degrees (Angle)
" (Dimension)	inches
(-)	Negative (Polarity)
(+)	Positive (Polarity)
AT	All-Terrain
CCW	Counter-clockwise
Conn.	Connector
CW	Clockwise
D	Diameter
DGHS	Deck, Grass Handling System (number refers to size in inches)
DML	Deck, Mulching (number refers to size in inches)
DSD	Deck, Side Discharge (number refers to size in inches)
DU	Garlock (Bearing)
ESNA (Fastener)	Nylon Insert Locknut
FSC	Forward Speed Control
GA	Gauge
gal.	gallon
GHS	Grass Handling System
GR (Fastener)	Grade
HP	Horse Power
HT	Heat-Treated
ID	Identification or Inside Diameter
L	Length
LH	Left Hand (orientated with operator on seat)
LP	Low Profile
mm (Dimension)	millimeters
MS (Fastener)	Machine Screw
NS (as part number)	Item is not sold by Walker Manufacturing
OD	Outside Diameter
oz.	ounce
PFH (Fastener)	Phillips Flat Head
P/N	Part Number
PPH (Fastener)	Phillips Pan Head
PTH (Fastener)	Phillips Truss Head
PTO	Power Take-Off
QKS	Quick Slide
qt.	quart
RH	Right Hand (orientated with operator on seat)
SAE (Fastener)	Society of Automotive Engineers
SBH (Fastener)	Socket Button Head (Bolt)
SD	Side Discharge
SFH (Fastener)	Slotted Flat Head
SHC (Fastener)	Socket Head Cap
SHL (Fastener)	Shoulder (Bolt)
SM (Fastener)	Sheet Metal (Screw)
S/N	Serial Number
Spg.	Spring
SQH (Fastener)	Square Head
SS (Fastener)	Stainless Steel
ST (Fastener)	Self-Tapping (Screw)
Term.	Terminal
V	Volts

**NOTE:** In some instances, combinations of abbreviations may be used (e.g. PPHMS - Phillips Pan Head Machine Screw).

Use only genuine **Walker**<sup>®</sup> replacement parts.

Effective Date 11-01-04

# ILLUSTRATED PARTS LIST

<i>Section of Mower Covered</i>	<i>Page</i>	<i>Section of Mower Covered</i>	<i>Page</i>
<hr/>		<hr/>	
<b>Decals</b>		<b>Electrical Components</b>	
Tractor Decals.....	2	Electrical Assemblies (Chassis Components) ....	32
<b>Body / Chassis Assemblies</b>		Electrical Assemblies (Body Components).....	34
Body / Chassis Assembly (GHS Models).....	4	Electrical Assemblies (GHS 6.7 Bushel Components).....	36
Body Assembly (GHS 9.5 Bushel Models) .....	6	(GHS 9.5 Bushel Components).....	38
Body Assembly (SD Models) .....	8	Electrical Connectors .....	40
<b>Tractor Components</b>		<b>Options and Kits</b>	
Main Component Power Transmission (GHS Models).....	10	Armrest Kit / Touch-Up Paint .....	42
(SD Models).....	12	Comfort Seat / Armrest Kit.....	44
Engine Group .....	14	Suspension Seat Kit .....	46
Hydrostatic Ground Drive Assemblies .....	16	Light Kit.....	48
Steering Control Assemblies.....	18	Blower Lockout Kit / Case-Hardened Blower.....	50
Throttle & Choke Control Assemblies .....	20	No Catch Deflector Kit (6.7 Bushel) .....	52
Parking Brake Assembly .....	22	No Catch Deflector Kit (9.5 Bushel) .....	54
GHS Group .....	24	All-Terrain Tire Kit & Tire Chain Sets.....	56
GHS Powerfil® Assembly .....	26	<b>Maintenance</b>	
GHS 6.7 Bushel Catcher & Exhaust Deflector Assemblies .....	28	Lubrication Points .....	58
GHS 9.5 Bushel Catcher & Exhaust Deflector Assemblies .....	30	Wiring Schematic.....	60
		<b>Warranty</b>	
		Limited Warranty.....	61

# TRACTOR DECALS

ITEM NO.	PART NO.	DESCRIPTION	LOCATION	NO. REQ'D. GHS	NO. REQ'D SD
<b>Walker Product and Operation Decals</b>					
1	7802	RH Fender	Body, RH near Seat	1	1
2	5856	Made in USA	Body, Spring Bracket	1	1
3	5803	Walker Manufacturing Logo	Body	1	1
4	5813-1	Powerfil®	6.7 / 9.5 Bushel Catcher, Front	1	0
5	5801	GHS	6.7 / 9.5 Bushel Catcher (one on each side)	2	0
6	5802-2	LH Fender	Body, LH near Seat	1	1
7	5800	Walker Mower (4 x 7-1/2)	Utility Bed (one on each side)	0	2
<b>Danger Decals Warning Decals Caution Decals</b>					
8	5805	Caution, Engine Exhaust	Body, LH Side	1	1
9	5806	Blade Clutch	Body, RH Side	1	1
10	5861	Danger, Raised Body	Body - Underside, Center	1	1
11	5804	Danger, Rotating Blower Blades	Body near Body Chute	1	0
12	6810	Danger, Engine Exhaust	Engine	1	1
13	5868	Danger, Pinch Point	6.7 / 9.5 Bushel Catcher Mounting Frame Assembly (one on each side)	2	0
<b>Maintenance Decals</b>					
14	5815	Body Lift	Rear Bumper	1	1
15	5855	Important, Engine Cooling	Engine	1	1
16	5810-2	Reservoir	Hydrostatic Drives (one on each)	2	2
17	5810-1	Axle Oil Level	Gear Axle Drive Assemblies (one on each)	2	2
18	5819	Blower Maintenance	Blower Housing	1	0
19	6875	PTO Alignment Arrow	Universal Joint Tube Assembly	1	1
20	7827	Oil Level	Jackshaft Support	1	1
21	5869	Removable Screen	6.7 / 9.5 Bushel Catcher Removable Screen	1	0
22	5874	Push to Release	6.7 / 9.5 Bushel Catcher Safety Latch	1	0
23	6807	Oil Pressure	Body	1	1
24	7809	Parking Brake	Body, RH below seat	1	1
<b>Option Decals (applied only to units with corresponding Options installed)</b>					
25	5877	Lights, On-Off	Body	1	1
	8500-8	No Catch Deflector	6.7 / 9.5 Bushel No Catch Deflector, LH Side (Refer to 6.7 or 9.5 Bushel No Catch Deflector Kit Listing)	1	0
	8500-9	No Catch Deflector, Off-On	Body, RH above fender (Refer to 6.7 Bushel No Catch Deflector Kit Listing)	1	0

**NOTE:** All parts requiring decals are shipped with decals applied.



# TRACTOR DECALS

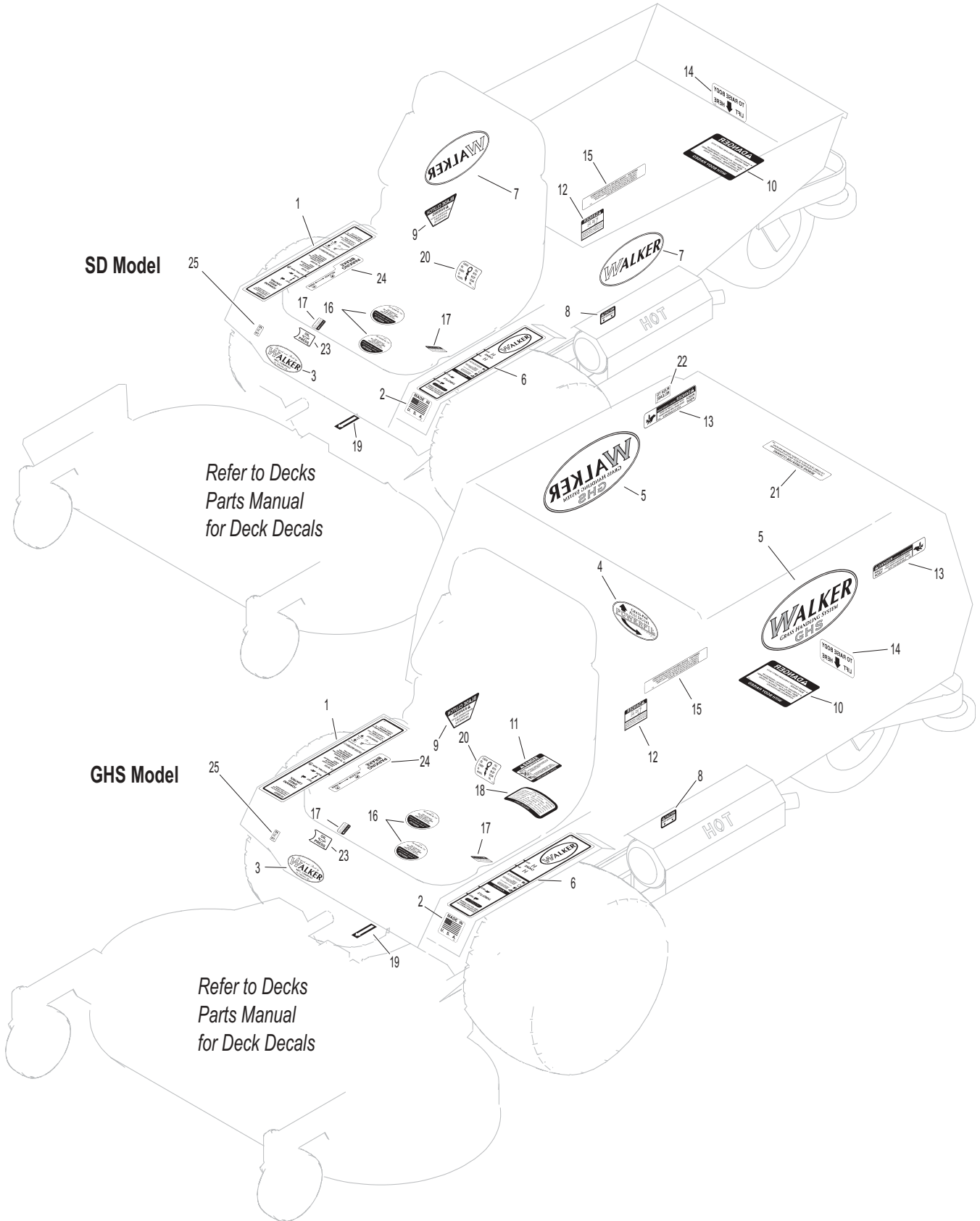

**SD Model**

*Refer to Decks  
Parts Manual  
for Deck Decals*

**GHS Model**

*Refer to Decks  
Parts Manual  
for Deck Decals*

# BODY / CHASSIS ASSEMBLY (GHS MODELS)

ITEM NO.	PART NO.	DESCRIPTION	NO. REQ'D	ITEM NO.	PART NO.	DESCRIPTION	NO. REQ'D
<b>Seat Assembly</b>				37	6389	Splash Guard	1
1	5103	Seat	1	38	5075	LP Wheel & Tire (18 x 8.50-10)	2
2	7203	Seat Spring Plate	1		5075-2	LP Tire (18 x 8.50-10)	**
3	7223	Compression Spring (1/2 x 1)	2		5075-4	LP Wheel (10 x 7)	**
4	7845	Rubber Bumper (1.375 OD x .63)	2		5033-2	Wheel & Tire (18 x 6.50-8)	***
5	7846	Washer (3/8 ID x 1-1/4 OD x 1/8)	2		5030-2	Standard Tire (18 x 6.50-8)	**
6	7204	Shoulder Bolt, Seat Mount	2		5031-2	Standard Wheel (8 x 5.5)	**
7	7440-5	Shock Mount (1-1/4 x 2)	2		5030-4	Tire Tube (18 x 8.50-8)	**
				39	6307-1	Chassis Frame	1
<b>Rear Bumper Assembly (GHS 6.7 Bushel Models Only)*</b>				<b>Fasteners</b>			
8	5566	Tilt Stop Strap	1		F002	10-24 Keps Nut	6
9	5516-8	Rear Bumper (6.7)	1		F004	1/4-20 Keps Nut	2
10	7516-5	Catcher Pivot Bushing	2		F009	5/16-18 Whiz Locknut	12
11	5162	Roller Wheel (5" Rubber)	2		F012	3/8-16 Keps Nut	2
12	6100-17	Bumper Riser Bar	2		F013	3/8-16 Whiz Locknut	2
13	7517-2	Catcher Pivot Plate	2		F014	3/8-16 ESNA Nut	4
<b>Body Assembly</b>					F016	1/2-13 Self-Locking Nut	1
14	6100-16	Welded Body	1		F020	5/16-18 ESNA Nut	1
15	5989-3	Dome Plug (5/16)	2		F026	10-24 x 1/2 PPHMS	5
16	5989-4	Dome Plug (3/8)	2		F027	10-24 x 5/8 PPHMS	1
17	7146	13mm Ball Stud	2		F029	1/4-20 x 1/2 Hex Bolt	4
18	5145	Gas Spring Assembly (Includes Items # 17 & 19)	1		F040	3/8-16 x 1-1/2 Hex Bolt	2
19	7147	Spring Clip	2		F042	3/8-16 x 2 1/4 Hex Bolt	2
20	5180	Edge Molding, Lever Opening	2		F048	1/2 SAE Washer	2
21	5989-5	Dome Plug (7/16)	1		F051	3/8 SAE Washer	2
22	NS	Body ID Plate	1		F059	3/8 Wave Spring Washer	2
<b>Tilt-Up Latch Assembly</b>					F085	3/16 Rivet Backup Washer	1
23	5847	Plastic Tip	1		F087	#10 x 7/8 Fender Washer	2
24	5744-20	Spring Arm, Tilt-Up Latch	1		F093	5/16-18 x 1 Hex Bolt	5
25	5744-10	Spring Pivot Bushing	1		F113	5/16-18 x 5/16 Set Screw	2
26	5744-15	Compression Spring (3/8 x 5/8)	1		F151	3/8-16 x 7/8 Hex Bolt	2
27	5744-13	Mount Angle / LH	1		F157	1/2-20 x 1-1/4 Wheel Lug Bolt	8
28	5744-12	Hook, Tilt-Up Latch	1		F206	#2 x 3/16 Drive Pin	2
29	5744-14	Mount Angle / RH	1		F227	3/8 x 1-1/4 x 1/8 Plastic Washer	2
<b>Chassis Assembly</b>					F241	.375 x .875 x .10 Washer	4
30	5845	Rubber Bumper (1.50 OD x 1.25)	2		F292	1/2-13 x 8-1/2 Hex Bolt GR 2	1
31	5267-1	Retainer Collar (1") (Includes Item # F113)	1		F341	Coil Roll Pin (7/64 x 9/16)	1
32	5270-1	Pivot Bearing	2		F342	5/16 Conical Washer	2
33	5420-2	Tail Wheel Fork	1				
34	5037-1	Bearing	2				
35	5035	Tail Wheel & Tire Assembly (13 x 6.50-6)	1				
	5035-1	Tail Wheel Tire (13 x 6.50-6)	**				
	5036	Tail Wheel & Hub (6 x 4.5)	**				
36	5038-1	Axle Spacer Tube (6-5/8)	1				

\* Rear Bumper Assembly for GHS 9.5 Bushel Models is not shown here. Refer to **BODY ASSEMBLY (GHS 9.5 BUSHEL MODELS)**, Page 6. Rear Bumper Assembly for SD Models is not shown here. Refer to **BODY ASSEMBLY (SD MODELS)**, Page 8.

\*\* Service Part Only

\*\*\* May be ordered as a factory-installed option or for dealer installation. Narrow Drive Tires are used when installing a 36" Deck. Contact your Walker dealer.



## BODY ASSEMBLY (GHS 9.5 BUSHEL MODELS)

ITEM NO.	PART NO.	DESCRIPTION	NO. REQ'D	ITEM NO.	PART NO.	DESCRIPTION	NO. REQ'D
<b>Body Assembly (GHS 9.5 Bushel Models Only)*</b>				<b>Fasteners</b>			
1	5566	Tilt Stop Strap	2	F002		10-24 Keps Nut	4
2	5516-9	Rear Bumper, GHS/9.5/C18	1	F009		5/16-18 Whiz Locknut	5
3	7516-5	Catcher Pivot Bushing	2	F012		3/8-16 Keps Nut	2
4	5162	Roller Wheel (5" Rubber)	2	F013		3/8-16 Whiz Locknut	2
5	7517-2	Catcher Pivot Plate	2	F014		3/8-16 ESNA Nut	2
6	6100-17	Bumper Riser Bar	2	F026		10-24 x 1/2 PPHMS	2
7	5845	Rubber Bumper (1.50 OD x 1.25)	1	F027		10-24 x 5/8 PPHMS	2
8	5516-10	Bumper Mount	1	F042		3/8-16 x 2-1/4 Hex Bolt	2
				F059		3/8 Wave Spring Washer	2
				F085		3/16 Rivet Backup Washer	2
				F087		#10 x 7/8 Fender Washer	4
				F093		5/16-18 x 1 Hex Bolt	4
				F151		3/8-16 x 7/8 Hex Bolt	2
				F213		3/4-10 Jam Nut	2
				F241		.375 x .875 x .10 Washer	4

\* Rear Bumper Assembly for GHS 6.7 Bushel Models is not shown here. Refer to **BODY / CHASSIS ASSEMBLY (GHS MODELS)**, Page 4. Rear Bumper Assembly for SD Models is not shown here. Refer to **BODY ASSEMBLY (SD MODELS)**, Page 8.

**NOTE:** Refer to **BODY / CHASSIS ASSEMBLY (GHS MODELS)**, Page 4 for all common parts used on both GHS and SD models.

# BODY ASSEMBLY (GHS 9.5 BUSHEL MODELS)

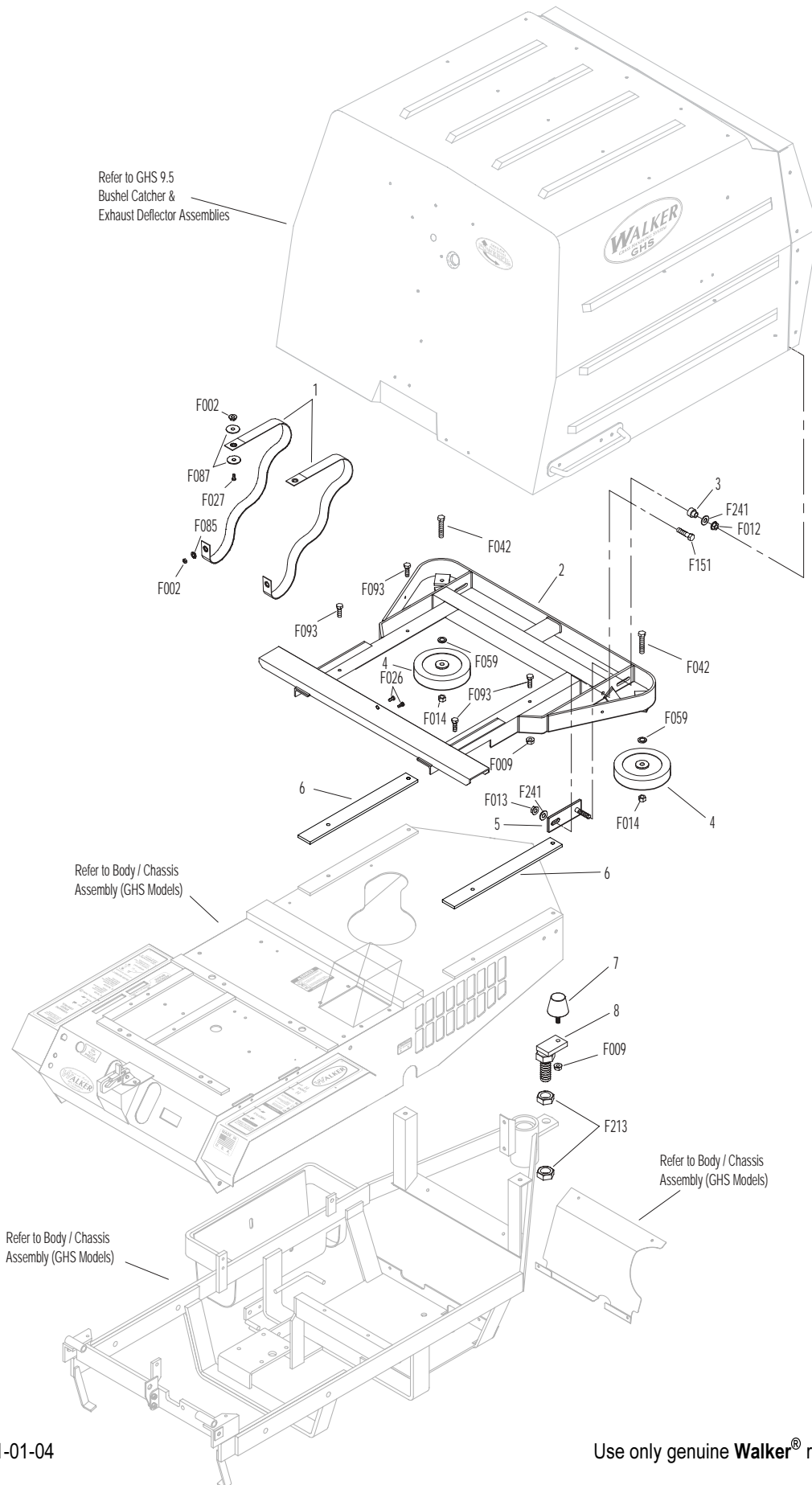

Effective Date 11-01-04

Use only genuine Walker® replacement parts.

# BODY ASSEMBLY (SD MODELS)

ITEM NO.	PART NO.	DESCRIPTION	NO. REQ'D	ITEM NO.	PART NO.	DESCRIPTION	NO. REQ'D
<b>Utility Bed Assembly</b>				<b>Fasteners</b>			
1	8650-10	Bed Liner (21.5 x 27.5)	1	F002		10-24 Keps Nut	4
2	5656	Utility Bed (Includes Items # 1 & 3)	1	F005		1/4-20 ESNA Nut	2
3	5845	Rubber Bumper (1.50 OD x 1.25)	2	F009		5/16-18 Whiz Locknut	10
4	5652-3	Utility Bed Mount / LH	1	F014		3/8-16 ESNA Nut	2
5	5651-2	Utility Bed Mount / RH	1	F020		5/16-18 ESNA Nut	2
<b>Rear Bumper Assembly (SD Models Only)*</b>				F033		1/4-20 x 1 PTH Bolt	2
6	7153-3	Cover Plate	1	F034		5/16-18 x 3/4 Hex Bolt	8
7	5112	Rear Bumper	1	F050		1/4 SAE Washer	2
8	5161	Bumper Pad	2	F059		3/8 Wave Spring Washer	2
9	5162	Roller Wheel (5" Rubber)	2	F084		5/16 Wave Spring Washer	2
				F091		5/16-18 x 5/8 Hex Bolt	2
				F128		10-24 x 3/8 PTHMS	4

\* Rear Bumper Assembly for GHS Models is not shown here. Refer to **BODY / CHASSIS ASSEMBLY (GHS MODELS)**, Page 4, or **BODY ASSEMBLY (GHS 9.5 BUSHEL MODELS)**, Page 6.

**NOTE:** Refer to **BODY / CHASSIS ASSEMBLY (GHS MODELS)**, Page 4 for all common parts used on both GHS and SD models.

# BODY ASSEMBLY (SD MODELS)

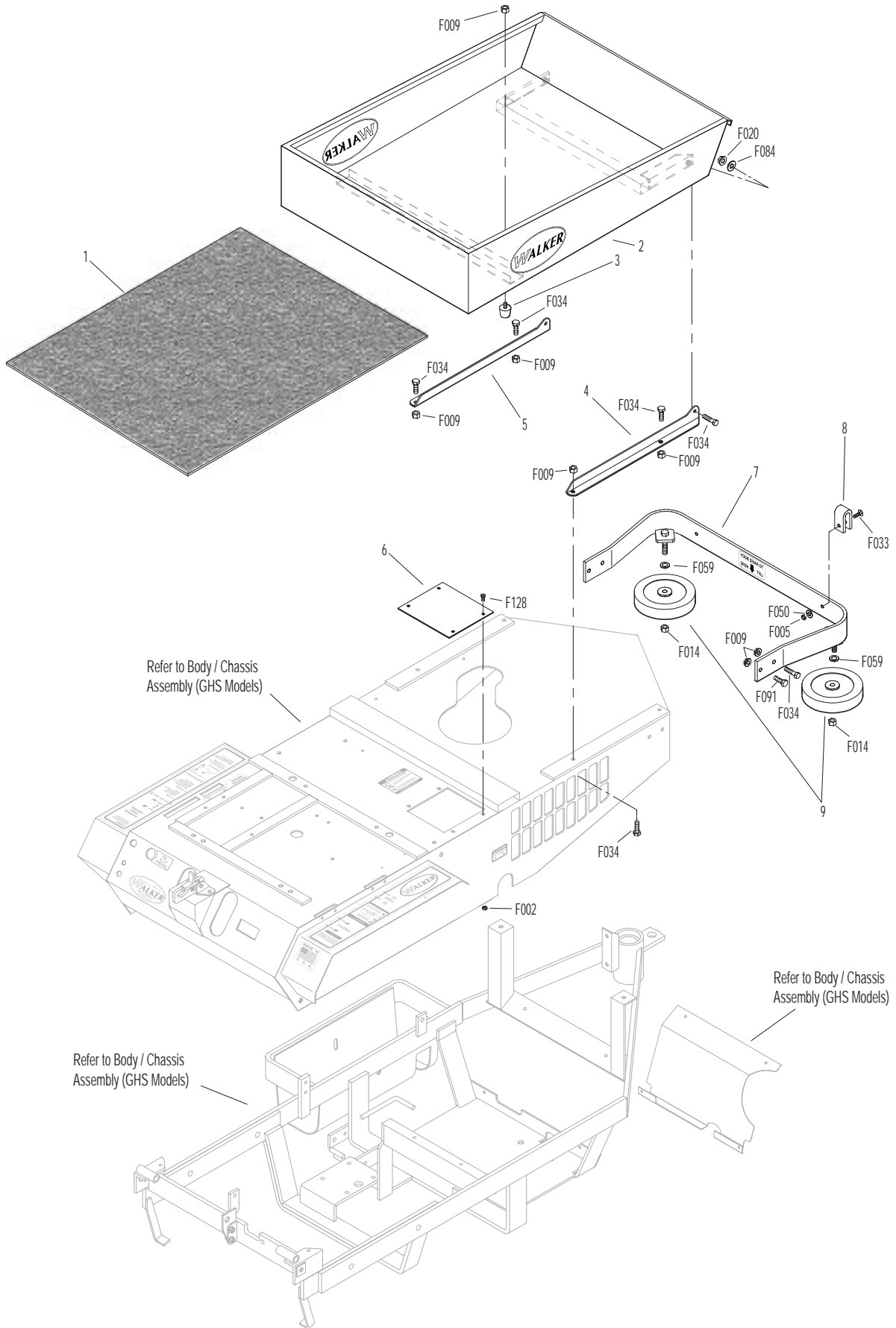

# MAIN COMPONENT POWER TRANSMISSION (GHS MODELS)

ITEM NO.	PART NO.	DESCRIPTION	NO. REQ'D	ITEM NO.	PART NO.	DESCRIPTION	NO. REQ'D
<b>Clutch Lever Assembly</b>				43	5268	Bearing with Collar (3/4)	2
1	6358-1	Clutch Lever (Includes Items # 2 & 3)	1	44	7833	Cable Clamp (7/8 x 1/4)	1
2	5830	Grease Fitting	7	45	7241-2	Transmission Drive Pulley (3-1/4 MV) (Includes Items # F067 & F171)	1
3	7860	Handle Grip	1	46	8539	Starter Relay Mount	1
4	7303-10	Clutch Actuator Bolt (3/8)	1	47	8349	Transmission Belt Tightener Arm	1
5	7380-5	Knuckle Joint (3/8 ID)	1	48	8393	Jackshaft Support	1
6	7226-10	Compression Spring (3/4 x 2-1/2)	1	49	8273	Jackshaft (3/4 x 7-1/2)	1
7	8130-5	Pushrod, Clutch Actuator	1	50	7240-3	Jackshaft Drive Pulley (4.15/3V) (Includes Items # F067 & F171)	1
8	8130-10	Clutch Actuator Rod Assembly (Includes Items # 2, 4-7, F054, F336 & F353)	1	<b>Fasteners</b>			
9	7201-3	DU Bearing	6		F002	10-24 Keps Nut	1
10	7201-5	Inner Race (2-1/4)	1		F003	1/4-28 Hex Nut	2
11	8368	PTO Belt Tightener	1		F004	1/4-20 Keps Nut	3
12	5841	Retainer Washer (3/8 x 1-1/4)	4		F005	1/4-20 ESNA Nut	1
13	8243-1	Clutch Idler Pulley	1		F009	5/16-18 Whiz Locknut	3
	8243	Clutch Idler Pulley Assembly (Includes Items # 14, 15 & F070)	*		F012	3/8-16 Keps Nut	8
14	5265	Bearing (3/4)	1		F025	10-24 x 3/8 PPHMS	1
15	8243-3	Hub, Idler Pulley	1		F029	1/4-20 x 1/2 Hex Bolt	1
16	8375	PTO Belt Tightener Stop	1		F034	5/16-18 x 3/4 Hex Bolt	2
17	7377	Plastic Washer (1 x .438 x .025)	2		F040	3/8-16 x 1-1/2 Hex Bolt	1
18	7378	Pivot Bearing (7/16 x 9/16)	1		F041	3/8-16 x 1-3/4 Hex Bolt	2
19	5281-5	Clevis Pin (1/4 x 0.80)	2		F042	3/8-16 x 2-1/4 Hex Bolt	3
20	5280	Clevis (1/4)	2		F043	3/8-16 x 3 Hex Bolt	1
21	8305	Brake Actuator Rod	1		F047	3/8-16 x 4-1/2 Hex Bolt	1
22	8370	Bearing, Brake Actuator	1		F054	AN960616 Washer	4
23	8250	Brake Spring (1/2 x 2-1/2)	1		F061	1/4 Internal Star Lock Washer	1
24	8369	Brake Actuator (Includes Items # 2 & 22)	1		F067	3/16 x 3/16 x 1 Key	2
<b>PTO Drive Shaft Assembly</b>					F069	3/32 x 1/2 Cotter Pin	2
25	7050-1	Dipstick, Gearbox	1		F070	1-3/4 Internal Snap Ring	1
26	8371-1	Mount Bracket, Brake Band	1		F116	1/4-20 x 1-1/4 Hex Bolt	1
27	8377	Brake Band Guide	1		F121	5/16-18 x 3/8 x 1 SHL Bolt	1
28	8050-11	PTO Gearbox / Flange Pulley	1		F131	5/16-18 x 1/2 Hex Bolt	2
29	5245	Idler Pulley (3")	2		F132	1/4-20 x 2-3/4 Hex Bolt	1
30	7248	Ground Drive Belt, Micro-V	1		F168	5/16 Split Lock Washer	12
31	7275-16	Universal Joint Tube Assembly (Spline)	1		F171	5/16-18 x 3/8 Set Screw	4
32	7523-2	Clevis Pin (1/4 x 5/8)	1		F178	1/4 x 1 Fender Washer	1
33	8304	Brake Band (14-1/2)	1		F182	5/8 x 1/4 x 1/8 Washer	2
34	6251-1	Drive Belt (3VX385)	1		F186	5/64 x 1/2 Cotter Pin	1
35	7236-1	PTO Drive Pulley (4-V213V) (Includes Items # F168 & F226)	1		F226	5/16-18 x 7/8 Hex Bolt	12
36	8237-2	Engine Pulley (4/3.8/3V) Bolt On (Includes Items # F168 & F226)	1		F241	.375 x .875 x .10 Washer	1
37	8230	Engine PTO Belt	1		F261	AN960616L Washer	1
<b>Jackshaft Assembly</b>					F325	1/4-20 x 3 Hex Bolt	1
38	7245-1	Idler Pulley (3/8 Groove)	1		F336	3/8-16 Jam Nut	1
39	6325-2	Spacer Bushing (5/16)	2		F353	3/8-16 ESNA LP Nut	1
40	8349-2	Idler Arm	1	* Service Part Only			
41	7201-4	Inner Race (1-1/2)	2				
42	5221	Extension Spring (3/4 x 4)	2				

Use only genuine **Walker**<sup>®</sup> replacement parts.

Effective Date 11-01-04



# MAIN COMPONENT POWER TRANSMISSION (GHS MODELS)

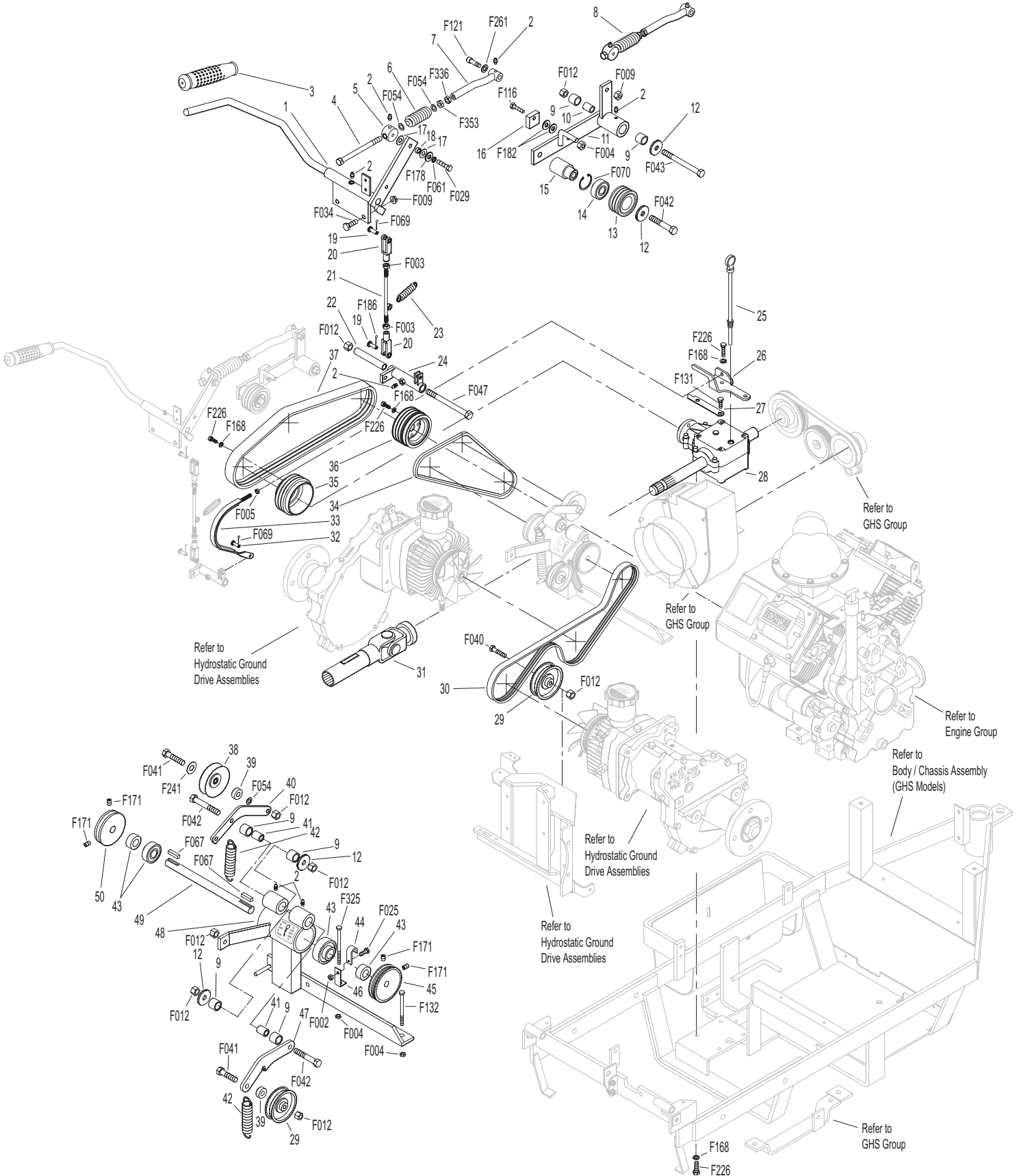

Effective Date 11-01-04

Use only genuine **Walker®** replacement parts.

# MAIN COMPONENT POWER TRANSMISSION (SD MODELS)

ITEM NO.	PART NO.	DESCRIPTION	NO. REQ'D	ITEM NO.	PART NO.	DESCRIPTION	NO. REQ'D	
<b>Clutch Lever Assembly</b>				43	7241-2	Transmission Drive Pulley (3-1/4 MV) (Includes Items # F067 & F171)	1	
1	6358-1	Clutch Lever (Includes Items # 2 & 3)	1	44	7833	Cable Clamp (7/8 x 1/4)	1	
2	5830	Grease Fitting	7	45	8539	Starter Relay Mount	1	
3	7860	Handle Grip	1	46	5268	Bearing with Collar (3/4)	2	
4	7303-10	Clutch Actuator Bolt (3/8)	1	47	8349	Transmission Belt Tightener Arm	1	
5	7380-5	Knuckle Joint (3/8 ID)	1	48	8393	Jackshaft Support	1	
6	7226-10	Compression Spring (3/4 x 2-1/2)	1	49	8273	Jackshaft (3/4 x 7-1/2)	1	
7	8130-5	Pushrod, Clutch Actuator	1	50	7240-3	Jackshaft Drive Pulley (4.15/3V) (Includes Items # F067 & F171)	1	
8	8130-10	Clutch Actuator Rod Assembly (Includes Items # 2, 4-7, F054, F336 & F353)	1	<b>Fasteners</b>				
9	7201-3	DU Bearing	6		F002	10-24 Keps Nut	1	
10	7201-5	Inner Race (2-1/4)	1		F003	1/4-28 Hex Nut	2	
11	8368	PTO Belt Tightener	1		F004	1/4-20 Keps Nut	3	
12	5841	Retainer Washer (3/8 x 1-1/4)	4		F005	1/4-20 ESNA Nut	1	
13	8243-1	Clutch Idler Pulley	1		F009	5/16-18 Whiz Locknut	3	
	8243	Clutch Idler Pulley Assembly (Includes Items # 14, 15 & F070)	*		F012	3/8-16 Keps Nut	8	
14	5265	Bearing (3/4)	1		F025	10-24 x 3/8 PPHMS	1	
15	8243-3	Hub, Idler Pulley	1		F029	1/4-20 x 1/2 Hex Bolt	1	
16	8375	PTO Belt Tightener Stop	1		F034	5/16-18 x 3/4 Hex Bolt	2	
17	7377	Plastic Washer (1 x .438 x .025)	2		F040	3/8-16 x 1-1/2 Hex Bolt	1	
18	7378	Pivot Bearing (7/16 x 9/16)	1		F041	3/8-16 x 1-3/4 Hex Bolt	2	
19	5281-5	Clevis Pin (1/4 x 0.80)	2		F042	3/8-16 x 2-1/4 Hex Bolt	3	
20	5280	Clevis (1/4)	2		F043	3/8-16 x 3 Hex Bolt	1	
21	8305	Brake Actuator Rod	1		F047	3/8-16 x 4-1/2 Hex Bolt	1	
22	8370	Bearing, Brake Actuator	1		F054	AN960616 Washer	4	
23	8250	Brake Spring (1/2 x 2-1/2)	1		F061	1/4 Internal Star Lock Washer	1	
24	8369	Brake Actuator (Includes Items # 2 & 22)	1		F067	3/16 x 3/16 x 1 Key	2	
<b>PTO Drive Shaft Assembly</b>						F069	3/32 x 1/2 Cotter Pin	2
25	7050-1	Dipstick, Gearbox	1		F070	1-3/4 Internal Snap Ring	1	
26	8371-1	Mount Bracket, Brake Band	1		F090	1/4-20 x 2-1/2 Hex Bolt	1	
27	8377	Brake Band Guide	1		F116	1/4-20 x 1-1/4 Hex Bolt	1	
28	8050-11	PTO Gearbox / Flange Pulley	1		F121	5/16-18 x 3/8 x 1 SHL Bolt	1	
29	5245	Idler Pulley (3")	2		F131	5/16-18 x 1/2 Hex Bolt	2	
30	7248	Ground Drive Belt, Micro-V	1		F132	1/4-20 x 2-3/4 Hex Bolt	1	
31	7275-16	Universal Joint Tube Assembly (Spline)	1		F168	5/16 Split Lock Washer	12	
32	7523-2	Clevis Pin (1/4 x 5/8)	1		F171	5/16-18 x 3/8 Set Screw	4	
33	8304	Brake Band (14-1/2)	1		F178	1/4 x 1 Fender Washer	1	
34	6251-1	Drive Belt (3VX385)	1		F182	5/8 x 1/4 x 1/8 Washer	2	
35	7236-1	PTO Drive Pulley (4-V213V) (Includes Items # F168 & F226)	1		F186	5/64 x 1/2 Cotter Pin	1	
36	8237-2	Engine Pulley (4/3.8/3V) Bolt On (Includes Items # F168 & F226)	1		F226	5/16-18 x 7/8 Hex Bolt	12	
37	8230	Engine PTO Belt	1		F241	.375 x .875 x .10 Washer	1	
<b>Jackshaft Assembly</b>						F261	AN960616L Washer	1
38	7245-1	Idler Pulley (3/8 Groove)	1		F336	3/8-16 Jam Nut	1	
39	6325-2	Spacer Bushing (5/16)	2		F353	3/8-16 ESNA LP Nut	1	
40	8349-2	Idler Arm	1	* Service Part Only				
41	7201-4	Inner Race (1-1/2)	2					
42	5221	Extension Spring (3/4 x 4)	2					

Use only genuine **Walker**<sup>®</sup> replacement parts.

Effective Date 11-01-04

# MAIN COMPONENT POWER TRANSMISSION (SD MODELS)

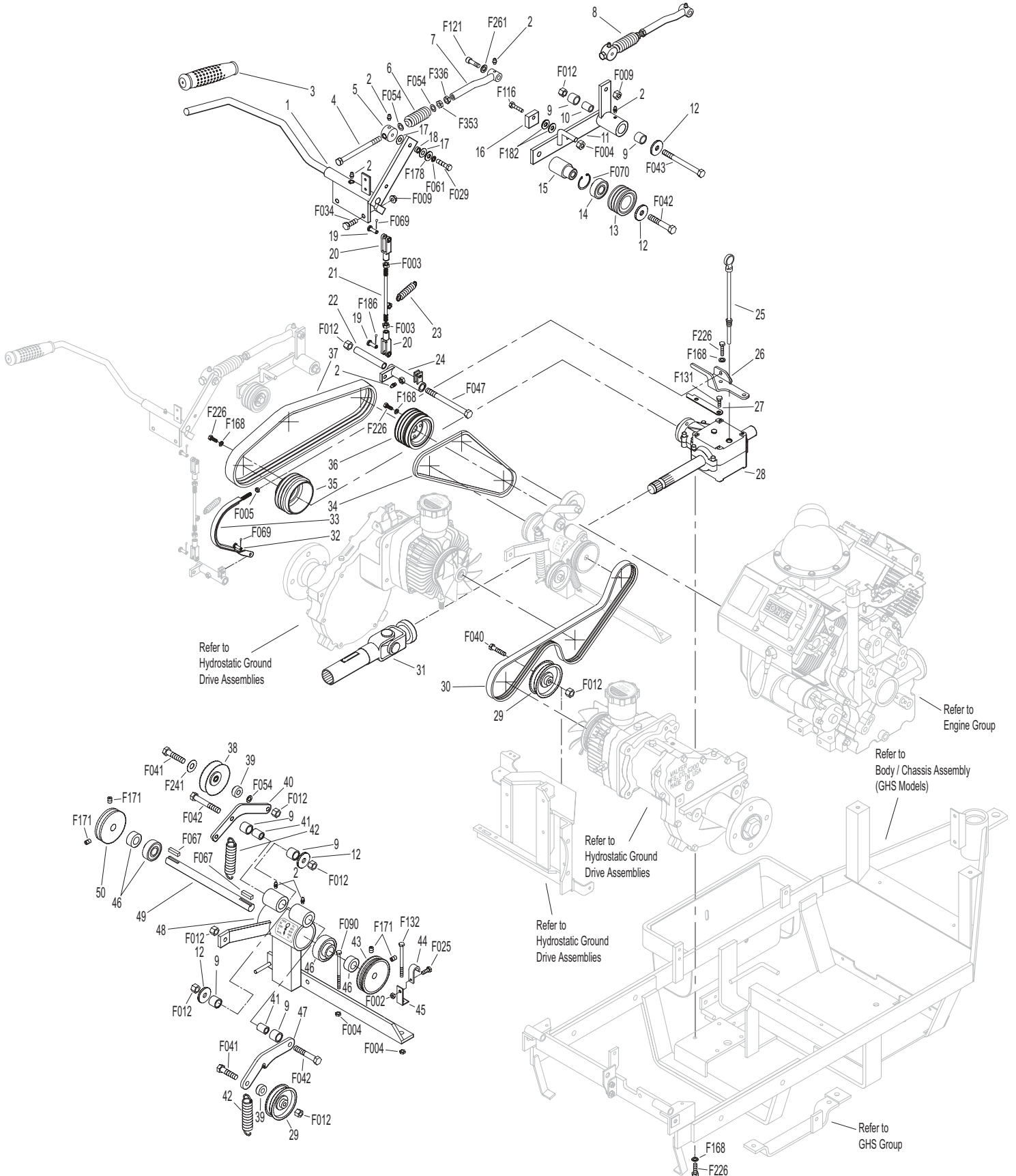

Effective Date 11-01-04

Use only genuine **Walker**® replacement parts.



# ENGINE GROUP

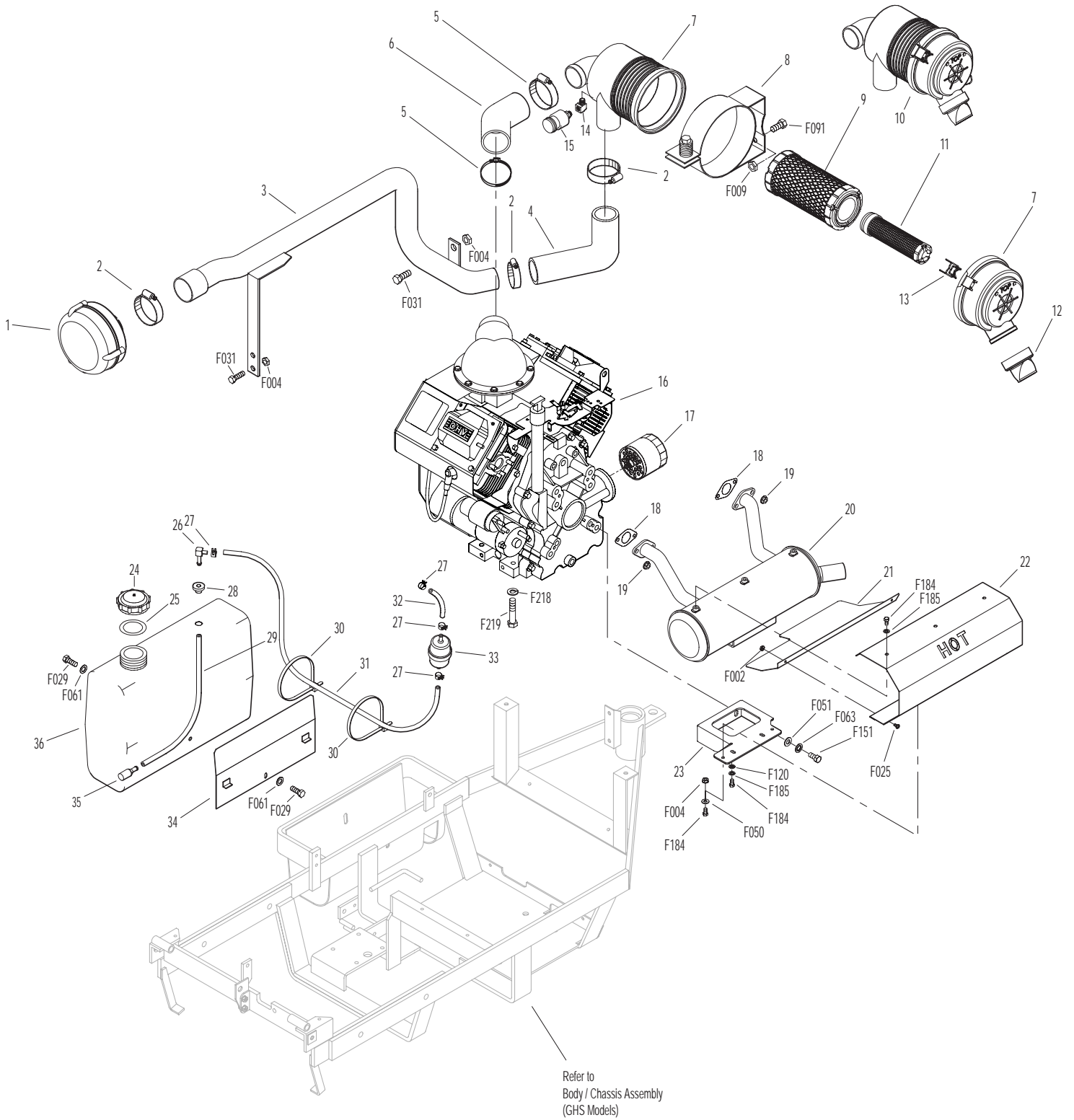

# HYDROSTATIC GROUND DRIVE ASSEMBLIES

ITEM NO.	PART NO.	DESCRIPTION	NO. REQ'D	ITEM NO.	PART NO.	DESCRIPTION	NO. REQ'D
<b>Transmission Lockout Assembly</b>				<b>Transmission Repair Parts</b>			
1	5028-3	Transmission Lockout Assembly with Mount* (Includes Items # 2-5, F023, F027 & F081)		26	5025-5	Input Shaft	*
2	5847	Plastic Tip	2	27	5025-8	Bearing, Input Shaft	*
3	5057	Lockout Cam (Includes Item # F081)	2	28	5025-7	Snap Ring	*
4	5028-5	Lockout Lever	2	29	5025-2	Seal, Input Shaft	*
5	5027-5	Lockout Mount	2	30	5022	Reservoir to Casting Gasket	*
<b>Ground Drive Assemblies</b>				31	5024	Reservoir Cap and Gasket	*
6	6209-1	Bridge Assembly	1	32	5023	Transmission Reservoir Kit	*
7	6243-2	Hydro Fan, CCW	1	33	5023-1	Rubber Bladder	*
8	5026	Hydrostatic Drive, CW (700-041)	1	34	5025-6	O-Ring & Plug	*
9	6206-1	Air Vent Valve	*	35	5025-3	Seal, Control Shaft	*
10	6200-9	Gear Axle Drive Assembly (Includes Item # 9 & 11)	2	<b>Fasteners</b>			
11	6207-12	Pipe Plug (1/4 NPTF)	4	F012	3/8-16 Keps Nut		1
12	5126	Cable Retainer (Uses existing bolt on Gear Axle Drive Assembly)	1	F023	10-24 ESNA Nut		2
13	6233-1	Pinion Gear	2	F027	10-24 x 5/8 PPHMS		2
14	6234	Spacer, Pinion Gear	2	F036	1/4-20 x 1/2 SBH Screw		2
15	6201	O-Ring Seal	2	F038	3/8-16 x 1 Hex Bolt		4
16	7244	Hydro Pulley (3-7/8 MV) (Includes Items # F064 & F359)	2	F040	3/8-16 x 1-1/2 Hex Bolt		4
17	6243-1	Hydro Fan, CW	1	F043	3/8-16 x 3 Hex Bolt		7
18	5025	Hydrostatic Drive, CCW (700-042)	1	F053	7/16 Internal Star Lock Washer		4
<b>Deck Support Arm Assemblies</b>				F063	3/8 Internal Star Lock Washer		16
19	6430-10	Outboard Mount, LH	1	F064	1/8 x 1/2 Woodruff Key (#3)		4
20	6430-2	Deck Support Arm, LH (Includes Item # 24)	1	F081	A/A45D Aluminum Pop Rivet		2
21	5775-2	Hitch Pin (# 6)	2	F160	External Snap Ring (.669 Shaft)		2
22	6430-1	Deck Support Arm, RH (Includes Item # 24)	1	F178	1/4 x 1 Fender Washer		2
23	6430-9	Outboard Mount, RH	1	F194	7/16 x 1-1/4 x 1/8 Washer		2
24	5830	Grease Fitting	2	F200	7/16-20 x 3 Grade 8 Bolt		2
25	6840-1	Support Arm Bushing (2-1/16)	2	F244	7/16-20 x 3/4 Hex Bolt		2
				F262	3/8-16 x 4 Hex Bolt (Spec) All Thread		1
				F359	5/16-18 x 5/16 Set Screw (Unbrako Knurl Point)		4
				* Service Part Only			

Use only genuine **Walker**<sup>®</sup> replacement parts.

Effective Date 11-01-04



# STEERING CONTROL ASSEMBLIES

ITEM NO.	PART NO.	DESCRIPTION	NO. REQ'D	ITEM NO.	PART NO.	DESCRIPTION	NO. REQ'D
<b>Transmission Spring Assemblies</b>				33	5281-5	Clevis Pin (1/4 x 0.80)	1
1	6199	Transmission Spring Assembly (RH) (Includes Items # 2-8, F003, F287, F320 & F352)	*	34	5470-1	Speed Control Stop	1
2	5552	Ball Joint (1/4-28)	2	35	5450-3	Steering Lever Assembly, RH (Includes Items # 16, 21, 36, F188, F198 & F345)	1
3	5192-1	Spring Plunger (5/32)	2		5450-5	Steering Lever Arm, RH / Adj.	*
4	5194	Plunger Sleeve	2	36	5453-10	Steering Lever Handle / Adj. (Includes Items # 21 & F345)	2
5	5193	Washer (3/4 x 1 x .085)	2	37	5862	FSC Knob	1
6	6191	Spring Slide (4-3/4)	1	38	7170	FSC Lever Assembly (Includes Item # 16)	1
7	5195	Compression Spring (1 x 5-1/8)	2	39	5213-1	Control Rod, RH (15")	1
8	6196	Spring Slide Cap	1	<b>Fasteners</b>			
9	5197	J-Bolt	1		F003	1/4-28 Hex Nut	3
10	5191	Spring Slide (3-5/8)	1		F004	1/4-20 Keps Nut	8
11	5199	Transmission Spring Assembly (LH) (Includes Items # 2-5, 7, 9, 10, F003, F146, F287 & F352)	*		F007	5/16-18 Jam Nut	1
<b>Steering Lever &amp; FSC Assemblies</b>					F008	5/16-24 Keps Nut	2
12	5214-2	Ball Joint (5/16-24) Nylon Lined	2		F009	5/16-18 Whiz Locknut	1
13	5173	FSC Actuator Rod	1		F010	5/16-24 ESNA Nut	2
14	5172	Bearing, Nylon (.255 x .379 x .250)	1		F012	3/8-16 Keps Nut	2
15	5142-2	FSC Actuator Cam	1		F024	5/16-24 Jam Nut	2
16	5830	Grease Fitting	6		F029	1/4-20 x 1/2 Hex Bolt	2
17	6212	Transmission Control Arm, RH	1		F032	1/4-20 x 3/4 Hex Bolt	4
18	5141	FSC Friction Washer (1-1/2 x 3/8 x 1/16)	2		F034	5/16-18 x 3/4 Hex Bolt	1
19	5140-15	FSC Friction Body (Includes Item # 16)	1		F050	1/4 SAE Washer	3
20	5142-7	FSC Key W/Stop	1		F051	3/8 SAE Washer	2
	5140-13	FSC Control Assembly (Includes Items # 16, 18-20, F192 & F193)	*		F064	1/8 x 1/2 Woodruff Key (#3)	2
21	5850-2	Handle Grip, Foam (5-1/2)	2		F068	1/8 x 1 Cotter Pin	1
22	5212-2	Transmission Control Arm, LH	1		F069	3/32 x 1/2 Cotter Pin	1
23	5213-2	Control Rod, LH (6")	1		F093	5/16-18 x 1 Hex Bolt	1
24	5223	Extension Spring (1/4 x 5-1/2)	2		F134	AN960816L Washer	3
25	5450	D-Clip	2		F146	1/4-20 Jam Nut	1
26	5463	Steering Lever Actuator	2		F182	1/4 x 5/8 x 1/8 Washer	3
27	5214-1	Bearing (.320 x .438 x .250)	2		F183	.312 x .700 x .074 Washer	2
28	5391-3	Steering Lever Support	1		F186	5/64 x 1/2 Cotter Pin	1
29	5217	Pivot Pin, Steering Lever	1		F188	1/4-20 Self-Locking Nut	4
30	5451-3	Steering Lever Assembly, LH / Adj. (Includes Items # 16, 21, 36, F188, F198 & F345)	1		F192	3/8-24 Self-Locking Nut	1
	5451-5	Steering Lever Arm, LH / Adj.	*		F193	3/8 Belleville Spring Washer	3
31	5219	Extension Spring (3/4 x 6-3/4)	1		F198	.250 x .625 x .040 Washer, SS	2
32	5280	Clevis (1/4)	1		F287	1/4-28 Keps Nut	2
					F345	1/4-20 x .770 Knurled Bolt	4
					F320	1/8 x 3/4 Split Spring Pin	1
					F352	5/32 x 1 Hvy Duty Roll Pin	2
				*	Service Part Only		

Use only genuine **Walker**<sup>®</sup> replacement parts.

Effective Date 11-01-04



# STEERING CONTROL ASSEMBLIES

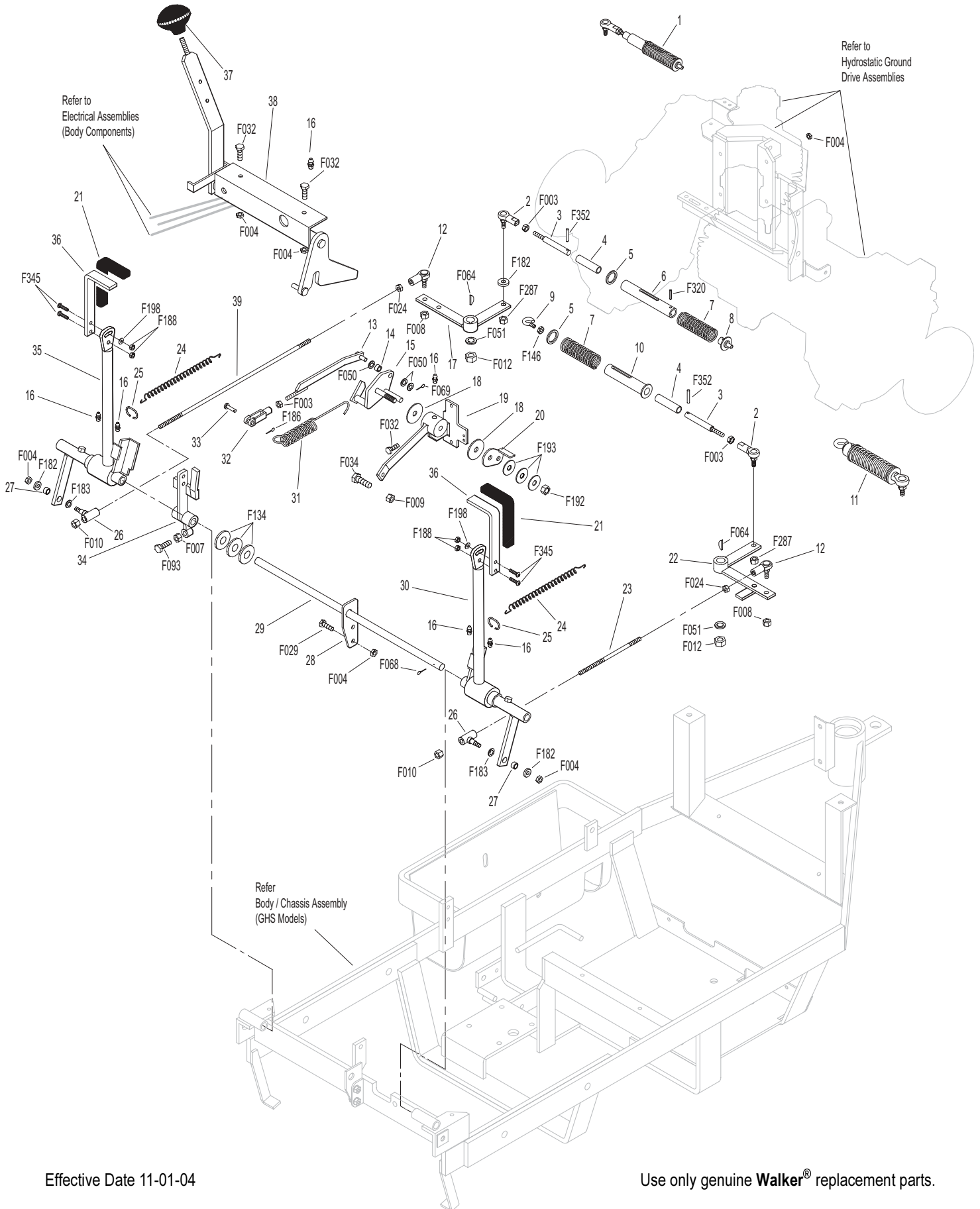

Effective Date 11-01-04

Use only genuine Walker® replacement parts.

# THROTTLE & CHOKE CONTROL ASSEMBLIES

ITEM NO.	PART NO.	DESCRIPTION	NO. REQ'D	ITEM NO.	PART NO.	DESCRIPTION	NO. REQ'D
<b>Throttle &amp; Choke Control Assemblies</b>				<b>Fasteners</b>			
1	8121-1	Throttle Cable	1	F004		1/4-20 Keps Nut	4
2	8122-1	Choke Cable	1	F005		1/4-20 ESNA Nut	2
3	5172	Bearing, Nylon (.255 x .379 x .250)	2	F029		1/4-20 x 1/2 Hex Bolt	2
4	5108-7	Control Lock Tab	2	F050		1/4 SAE Washer	2
5	5108-10	Friction Washer (.125)	2	F164		10-24 x 1/4 x 3/8 SHL Bolt	2
6	5108-1	Control Lever, Throttle & Choke	2	F201		1/4 Belleville Spring Washer	4
7	5108-5	Throttle Control Knob, Red	1				
8	5108-11	Friction Washer (.062)	2	*		Service Part Only	
9	5108-8	Control Bracket	2				
10	7108	Control Assembly (Includes Items # 4-6, 8, 9 & F201)	2				
	8121	Throttle Control and Cable Assembly (Includes Item # 7)	*				
	8122	Choke Control and Cable Assembly (Includes Item # 11)	*				
11	5108-6	Choke Control Knob, Black	1				
12	8123	Insulation Sleeve (3/8 x 6)	1				
13	5975-3	Cable Tie (50# x 7")	1				
14	5975-1	Cable Tie (18# x 3-3/4")	1				

# THROTTLE & CHOKE CONTROL ASSEMBLIES

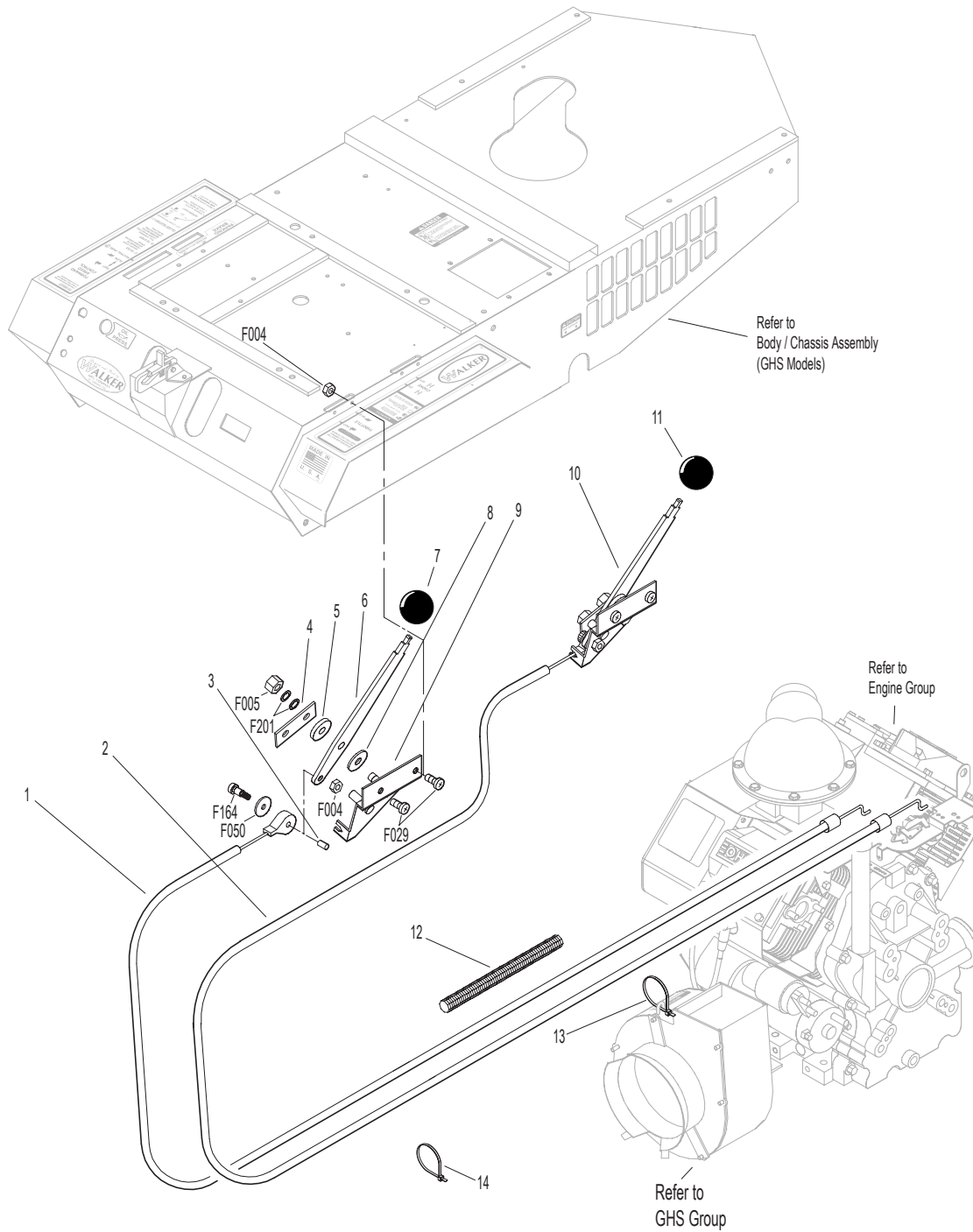

# PARKING BRAKE ASSEMBLY

ITEM NO.	PART NO.	DESCRIPTION	NO. REQ'D	ITEM NO.	PART NO.	DESCRIPTION	NO. REQ'D
<b>Parking Brake Assembly</b>				<b>Fasteners</b>			
1	7406-1	Handle Grip, Red	1	F002		10-24 Keps Nut	2
2	7406-8	Parking Brake Lever (4-1/4)	1	F003		1/4-28 Hex Nut	1
3	7406-2	Lever Mount	1	F004		1/4-20 Keps Nut	4
4	5830	Grease Fitting	1	F025		10-24 x 3/8 PPHMS	2
5	7407	Clevis Pin (3/16 x 1/2)	2	F029		1/4-20 x 1/2 Hex Bolt	3
6	7404	Brake Actuator Arm	2	F032		1/4-20 x 3/4 Hex Bolt	1
7	7405	Pin, Transmission Lock	2	F054		AN960616 Washer	2
8	7402	Clevis	2	F072		1/4 "E" Retainer Ring	2
9	7408	Compression Spring (1/2 x 3/4)	2	F086		#10 SAE Washer	4
10	7415	Rubber Dust Shield (5/8 x 3/8 x 1/32)	2	F109		1/8 x 5/8 Roll Pin	2
11	5567-3	O-Ring Seal (1/4 x 3/8)	4	F111		1/8 x 3/4 Cotter Pin	1
12	7403	Plunger Bushing, Gear Axle	2	F112		5/8 x 1-1/4 x .03 Washer	2
13	7404-1	Brake Actuator Mount	2	F127		1/16 x 1/2 Cotter Pin	4
14	7412	Clevis Pin (3/16 x 5/8)	2	F261		AN960616L Washer	5
15	5833	Cable Clamp (1/4)	2	F287		1/4-28 Keps Nut	1
16	7410	Brake Control Cable, LH (27")	1				
17	7409	Brake Control Cable, RH (21")	1				
18	7401-3	Cable Mount Bracket	1				
19	7401-1	Cable Pull Rod	1				
20	5552	Ball Joint (1/4-28)	1				

# PARKING BRAKE ASSEMBLY

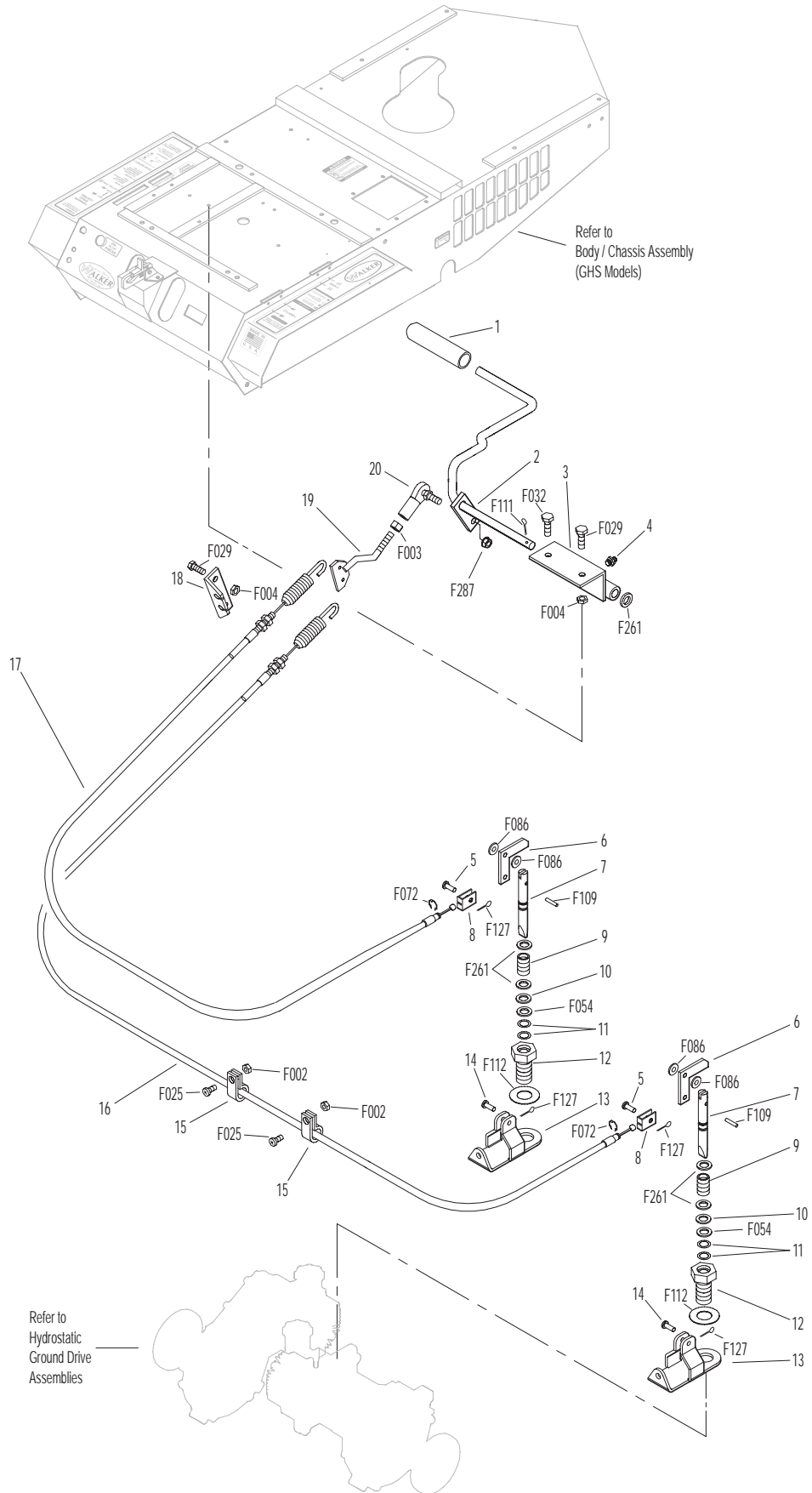

# GHS GROUP

ITEM NO.	PART NO.	DESCRIPTION	NO. REQ'D
----------	----------	-------------	-----------

### Delivery Chute Assembly

When Optional 9.5 Bushel Catcher Assembly is purchased, Item # 6 is replaced by P/N 8511-1 (Delivery Chute Assembly, 9.5).

1	5515-2	Elbow Delivery Spout	1
2	5592-13	Backing Plate, Grass-Pak® Switch	1
3	5592-12	Mount Plate, Grass-Pak® Switch	1
4	5578	Rear Clip, Chute Mount	1
5	5577	Side Clip, Chute Mount	2
6	5511-3	Delivery Chute, with Clips, 6.7 (Includes Items # 4, 5, 7, F079, F085 & F362)	1
	8511-1	Delivery Chute, with Clips, 9.5 (Includes Items # 4, 5, 7, F079, F085 & F362)	*
7	5578-10	Front Clip, Chute Mount	1
8	6530-4	Body Chute (10")	1

### Blower Belt Tightener Assembly

9	7238-1	Blower Drive Pulley (Mirco-V) (Includes Items # F075, F114 & F231)	1
10	7234-1	Blower Belt (Micro-V)	1
11	7239-1	Blower Pulley (Mirco-V) (Includes Items # F067, F075 & F114)	1
12	7364-2	Torsion Spring	1
13	7201-3	DU Bearing	2
14	5830-3	Grease Fitting (45 Deg.)	1
15	7364-1	Blower Belt Tightener Arm	1
16	7201-4	Inner Race (1-1/2)	1
17	5841	Retainer Washer (3/8 x 1-1/4)	1
18	5245	Idler Pulley (3")	1

### Blower Assembly

19	5268	Bearing W/Collar (3/4)	2
20	6543	Housing (10" Blower)	1
	6542	Blower Assembly (10") (Includes Items # 19, 22, 23 & F004)	*
21	6545	Blower Wheel (10")	1
22	6525-2	Faceplate (10" Blower)	1
23	6526	Intake Tube (6-1/2 x 2-1/2)	1
24	5595-2	Intake Cover/GHS	**
25	7528	Skid Bar (10" Blower)	1

ITEM NO.	PART NO.	DESCRIPTION	NO. REQ'D
----------	----------	-------------	-----------

### Fasteners

F002	10-24 Keps Nut	8
F004	1/4-20 Keps Nut	6
F009	5/16-18 Whiz Locknut	1
F012	3/8-16 Keps Nut	3
F025	10-24 x 3/8 PPHMS	2
F026	10-24 x 1/4 PPHMS	2
F034	5/16-18 x 3/4 Hex Bolt	1
F038	3/8-16 x 1 Hex Bolt	1
F040	3/8-16 x 1-1/2 Hex Bolt	1
F042	3/8-16 x 2-1/4 Hex Bolt	1
F054	AN960616 Washer	1
F067	3/16 x 3/16 x 1 Key	1
F074	1/4-20 x 3/8 Set Screw	2
F075	5/16-18 x 1/2 SQH Set Screw	2
F079	A/A66D Aluminum Pop Rivet	12
F085	3/16 Rivet Backup Washer	12
F102	10-24 x 1-1/2 PTHMS	2
F114	5/16-18 x 5/8 SQH Set Screw	2
F128	10-24 x 3/8 PTHMS	4
F217	7/16-14 Hex Nut	1
F218	7/16 Split Lock Washer	1
F219	7/16-14 x 1-1/4 Hex Bolt	1
F231	1/4 x 3/4 Woodruff Key (# 806)	1
F362	A/A62D Alum. Pop Rivet (3/16D x 13/32L)	2

\* Service Part Only

\*\* Plugs Blower when GHS is not in use. Furnished only with Mulching Decks, SD Decks used on a GHS Tractor, Rotary Broom Attachment and Snowblower Attachment. Use of this part may be replaced by installing Blower Lockout Kit (P/N 6541). See Page 50.



# GHS POWERFIL® ASSEMBLY

ITEM NO.	PART NO.	DESCRIPTION	NO. REQ'D	ITEM NO.	PART NO.	DESCRIPTION	NO. REQ'D
<b>GHS Powerfil® Assembly</b>				<b>Fasteners</b>			
1	5557	Motor Mount, Powerfil®	1	F002		10-24 Keps Nut	8
2	5551-3	Bearing Cap, Powerfil®	1	F003		1/4-28 Hex Nut	4
3	5551-1	Pivot Bearing (#S3PP)	2	F025		10-24 x 3/8 PPHMS	1
4	5552	Ball Joint (1/4-28)	2	F054		AN960616 Washer	1
5	5518-2	Pivot, Delivery Spout	1	F061		1/4 Internal Star Lock Washer	1
6	5517-2	Pivot Mount	1	F085		3/16 Rivet Backup Washer	1
7	5558-1	Powerfil® Pushrod	1	F101		10-24 x 1-1/4 SHC Screw	1
8	5553-3	Bushing, Powerfil® Actuator	4	F109		1/8 x 5/8 Roll Pin	1
9	5558-2	Powerfil® Actuator Rod	1	F129		10-24 x 1/2 PTHMS	7
	5549	Actuator Rod Assembly (Includes Items # 4, 7-10 & F003)	*	F261		AN960616L Washer	1
10	5553-1	Compression Spring (1/2 x 2)	2	F287		1/4-28 Keps Nut	1
11	5554	Actuator Arm	1	* Service Part Only			
12	5519-3	Motor Mount Nut (5/8-24)	*				
13	5519-2	Motor Mount Washer	*				
14	5519	Actuator Motor (12/24V) (Includes Items # 12 & 13)	1				
15	5977	Grommet (1/2 x 7/8 x 1/16)	1				



# GHS POWERFIL® ASSEMBLY

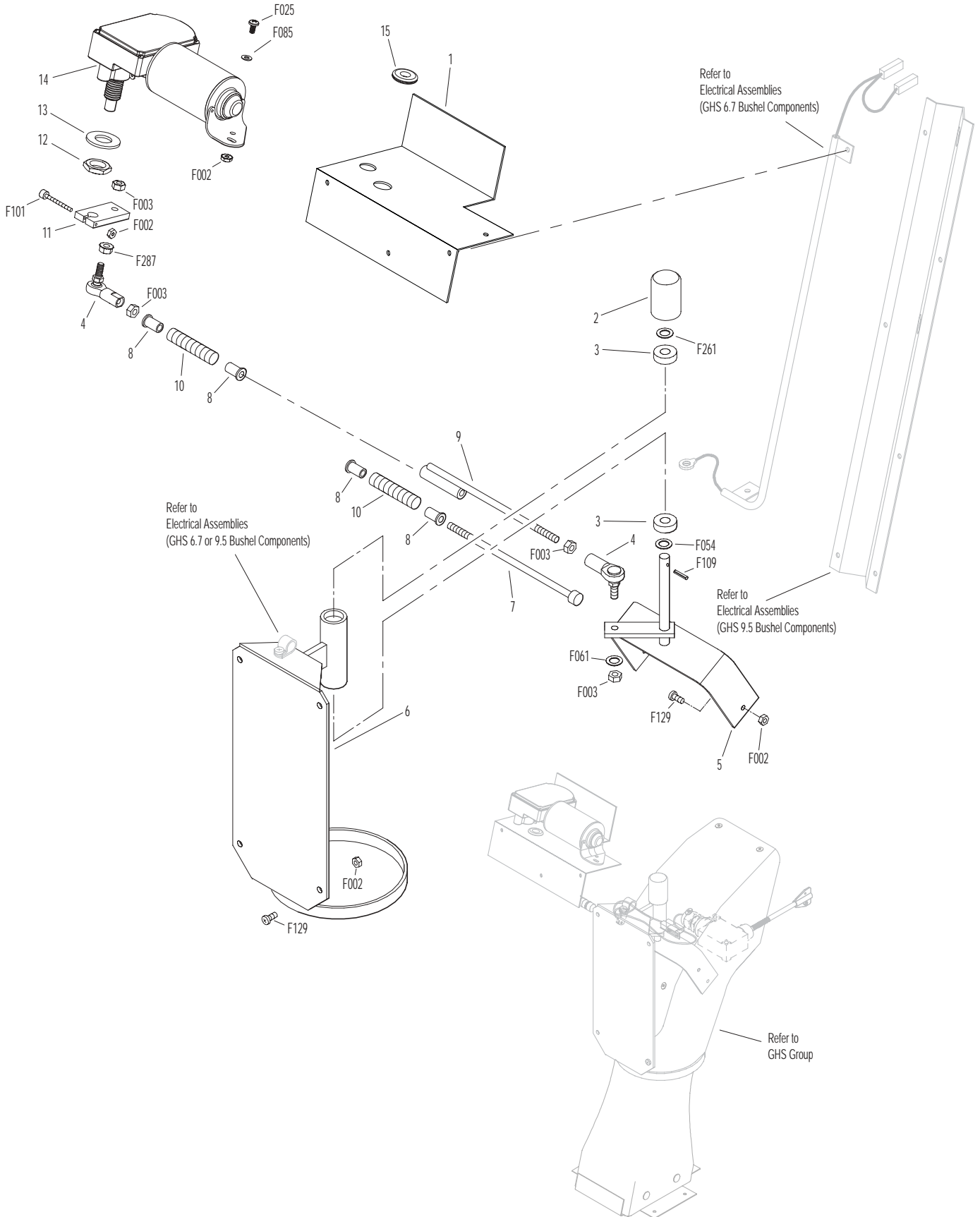

# GHS 6.7 BUSHEL CATCHER & EXHAUST DEFLECTOR ASSEMBLIES

ITEM NO.	PART NO.	DESCRIPTION	NO. REQ'D	ITEM NO.	PART NO.	DESCRIPTION	NO. REQ'D
<b>Upper Baffle Screen Assembly (Removable)</b>				27	7532	Handle, Catcher Lift	2
					7534	Catcher Handle Kit (Includes Items # 27, 28, F004 & F172)	**
1	7509-3	Channel Bottom	2	28	7533	Backing Plate, Handle	2
2	7505	Mustache Spring	2	29	5155-15	Box Support, Gas Spring	2
3	6507	Screen Seal (24")	1	30	6508	Safety Latch	1
4	6856-1	Edge Molding (21-3/4)	1	31	5522-2	Hinge Backup Plate, RH	1
5	7509-2	Channel Top	2	32	5584	Reinforcing Strap	2
6	6512-2	Removable Screen (3/16 Hole) (Includes Items # 4, 7, F025 & F190)	1*	<b>5598 Optional Dump Bag (Not Shown)</b>			
7	7506	Knob (10-24) Threaded Insert	2	May be ordered as an option. Contact your Walker dealer.			
8	6509-4	C-Channel (6.7)	1				
<b>Exhaust Deflector Assembly</b>				<b>Fasteners</b>			
	5504	Exhaust Deflector Kit, 6.7	**	F002		10-24 Keps Nut	23
9	5504-3	Hinge (22")	1	F004		1/4-20 Keps Nut	16
10	5504-1	Exhaust Deflector (2 Piece / 6.7)	1	F009		5/16-18 Whiz Locknut	2
11	5504-8	Deflector Mount Doubler	2	F020		5/16-18 ESNA Nut	2
<b>GHS 6.7 Bushel Catcher Assembly</b>				F025		10-24 x 3/8 PPHMS	4
12	5583	Handle	1	F026		10-24 x 1/2 PPHMS	8
13	5588	Rubber Bumper (.75 x .50)	2	F027		10-24 x 5/8 PPHMS	4
14	5130	Side Strap, Door (6.7)	2	F035		5/16-18 x 1-1/4 Hex Bolt	1
15	5514-10	6.7 Door Frame, Gas Spring	1	F037		10-24 x 5/8 PTH Screw	4
16	5510-1	6.7 Bushel Catcher, with Door	1	F049		5/16 SAE Washer	5
	5502-1	6.7 Catcher, W/O Powerfil®, (Includes Door & Deflector)	***	F079		A/A66D Aluminum Pop Rivet	11
	5502-2	6.7 Catcher w/Powerfil®, (Includes Door & Deflector)	***	F085		3/16 Rivet Backup Washer	21
17	5503	6.7 Mounting Frame	1	F129		10-24 x 1/2 PTHMS	10
18	5513-1	6.7 Mounting Frame Doubler	1	F172		1/4-20 x 3/4 Carriage Bolt	4
19	5522-1	Hinge Backup Plate, LH	1	F188		1/4-20 Self Locking Nut	17
20	5155-12	5/16 Ball Stud	2	F190		#10 Internal Star Lock Washer	2
21	5147	Spring Clip	4	F195		1/4-20 x 3/4 PPHMS SS	8
22	5155-2	Gas Spring Cover	2	F196		1/4-20 x 1 PPHMS SS	2
23	5155	Gas Spring Assembly/Catcher Door (Includes Items # 20, 21, 25 & F049)	2	F198		.625 x .250 x .040 Washer, SS	9
24	5524-1	Flanged Hinge Bearing	2	F203		1/4-20 x 5/8 PPHMS SS	4
25	5155-13	3/4 Ball Stud	2	F230		1/4-20 x 1-1/4 PPHMS SS	1
26	5523-6	Gas Spring Plate	2	F242		1/4-20 x 7/8 PPHMS SS	14
				F252		10-24 x 3/4 PPHMS	1
				F255		5/16-18 x 1-1/2 Hex Bolt	1
				F329		.260 ID x 1.939 OD Washer	2
				F330		3/16 D x 21/32 L Rivet, SS	2
				F351		Aluminum Pop Rivet	6

\* This screen can be replaced by P/N 6512-3 Removable Screen (3/4" holes) for improved air flow performance in wet conditions.

\*\* This kit is sold as a complete assembly, including mounting hardware.

\*\*\* Service Part Only



# GHS 9.5 BUSHEL CATCHER & EXHAUST DEFLECTOR ASSEMBLIES

ITEM NO.	PART NO.	DESCRIPTION	NO. REQ'D	ITEM NO.	PART NO.	DESCRIPTION	NO. REQ'D
<b>Upper Baffle Screen Assembly (Removable)</b>				31	5155-15	Box Support, Gas Spring	2
1	7509-3	Channel Bottom	2	32	7508	Safety Latch (7.0 / 9.5)	1
2	7505	Mustache Spring	2	33	5522-2	Hinge Backup Plate, RH	1
3	7507	Screen Seal (27-1/2)	1	34	7584	Reinforcing Strap	2
4	7856-1	Edge Molding (26")	1	35	8515-10	Catcher Reinforcing Plate	2
5	7509-2	Channel Top	2	<b>5598 Optional Dump Bag (Not Shown)</b>			
6	7512-2	Removable Screen (3/16 Hole) (Includes Items # 4, 7, F025 & F190)	1****	May be ordered as an option. Contact your Walker dealer.			
7	7506	Knob (10-24) Threaded Insert	2	<b>Fasteners</b>			
8	7509-4	C-Channel (7.0 / 9.5)	1	F002	10-24 Keps Nut		15
<b>Exhaust Deflector Assembly</b>				F004	1/4-20 Keps Nut		21
	7504	Exhaust Deflector Kit, 7.0 / 9.5	*	F009	5/16-18 Whiz Locknut		2
9	7504-3	Hinge (27")	1	F020	5/16-18 ESNA Nut		2
10	7504-1	Exhaust Deflector (Two Piece)	1	F025	10-24 x 3/8 PPHMS		4
11	7504-8	Deflector Mount Doubler	2	F026	10-24 x 1/2 PPHMS		8
<b>GHS 9.5 Bushel Catcher Assembly**</b>				F027	10-24 x 5/8 PPHMS		4
12	5583	Handle	1	F035	5/16-18 x 1-1/4 Hex Bolt		1
13	8516	Side Strap, Door / 9.5	2	F037	10-24 x 5/8 PTH Screw		2
14	5588	Rubber Bumper (.75 x .50)	2	F049	5/16 SAE Washer		4
15	7514-1	Backup Plate	1	F079	A/A66D Aluminum Pop Rivet		33
16	8514-11	9.5 Door Frame	1	F085	3/16 Rivet Backup Washer		24
17	8510-1	9.5 Bushel Catcher Box (Includes Door)	1	F129	10-24 x 1/2 PTHMS		14
	8502-1	9.5 Catcher W/O Powerfil® (Includes Door & Deflector)	***	F172	1/4-20 x 3/4 Carriage Bolt		4
	8502-2	9.5 Catcher (Includes Powerfil®, Door & Deflector)	***	F188	1/4-20 Self Locking Nut		20
18	8513-3	9.5 Mount Frame Doubler	1	F190	#10 Internal Star Lock Washer		2
19	8503-2	9.5 Mounting Frame (Includes Item # 21)	1	F195	1/4-20 x 3/4 PPHMS SS		8
20	5522-1	Hinge Backup Plate, LH	1	F196	1/4-20 x 1 PPHMS SS		3
21	7503-9	Pivot Bushing (5/16 x 5/8)	2	F198	.625 x .250 x .040 Washer, SS		5
22	5155-12	5/16 Ball Stud	2	F230	1/4-20 x 1-1/4 PPHMS SS		1
23	5147	Spring Clip	4	F242	1/4-20 x 7/8 PPHMS SS		23
24	5155-2	Gas Spring Cover	2	F252	10-24 x 3/4 PPHMS		1
25	5155	Gas Spring Assembly/Catcher Door (Includes Items # 22, 23, 27 & F049)	2	F255	5/16-18 x 1-1/2 Hex Bolt		1
26	5524-1	Flanged Hinge Bearing	2	F329	.260 ID x 1.939 OD Washer		2
27	5155-13	3/4 Ball Stud	2	F330	3/16 D x 21/32 L Rivet, SS		2
28	5523-6	Gas Spring Plate	2	F351	Aluminum Pop Rivet		6
29	7533	Backing Plate, Handle	2	F390	1/4-20 x 7/8 Carriage Bolt		2
30	7532	Handle, Catcher Lift	2	* This kit is sold as a complete assembly, including mounting hardware.			
	7534	Catcher Handle Kit (Includes Items # 29, 30, F004 & F172)	*	** May be ordered as a factory-installed option. Contact your Walker dealer.			
				*** Service Part Only			
				**** This screen can be replaced by P/N 7512-3 Removable Screen (3/4" holes) for improved air flow performance in wet conditions.			

Use only genuine Walker® replacement parts.

Effective Date 11-01-04



# ELECTRICAL ASSEMBLIES (CHASSIS COMPONENTS)

ITEM NO.	PART NO.	DESCRIPTION	NO. REQ'D	ITEM NO.	PART NO.	DESCRIPTION	NO. REQ'D
<b>Battery Assembly</b>				<b>Fasteners</b>			
1	5932	Battery Terminal Insul., Black (-)	1	F002		10-24 Keps Nut	9
2	5975-1	Cable Tie (18# x 3-3/4")	2	F004		1/4-20 Keps Nut	5
3	5933	Battery Terminal Insul., Red (+)	1	F009		5/16-18 Whiz Locknut	1
4	5910	Battery (12V/U1-SP30/Dry)	1	F019		1/4-20 ESNA Wing Nut	2
5	5844	Battery Hold-Down Bar	1	F025		10-24 x 3/8 PPHMS	1
6	6392	Battery Protector Plate	1	F026		10-24 x 1/2 PPHMS	3
7	5839	Hook Bolt	2	F027		10-24 x 5/8 PPHMS	2
8	6390	Battery Pan	1	F031		1/4-20 x 5/8 Hex Bolt	2
9	6923	Battery Cable (-)	1	F032		1/4-20 x 3/4 Hex Bolt	3
10	8943	Battery Lead Wire (+)	1	F050		1/4 SAE Washer	6
				F093		5/16-18 x 1 Hex Bolt	1
				F129		10-24 x 1/2 PTHMS	1
<b>Harness Assembly</b>				<b>NOTE:</b> Refer to <b>ELECTRICAL CONNECTORS</b> , Page 40 for identification of all Electrical Wiring Service Parts.			
11	8941	Circuit Breaker (30 Amp) Auto Reset / Sealed	1				
12	7948-1	Time Delay Module	1				
13	6941	Relay Switch (30/40 Amp)	1				
14	7948-3	Time Delay Harness	1				
15	5975-3	Cable Tie (50# x 7")	6				
16	5942-5	Safety Switch (NO)	2				
17	5833	Cable Clamp (1/4)	1				
18	6940-4	Wire Harness	1				



# ELECTRICAL ASSEMBLIES (BODY COMPONENTS)

ITEM NO.	PART NO.	DESCRIPTION	NO. REQ'D	ITEM NO.	PART NO.	DESCRIPTION	NO. REQ'D
<b>Electrical Assemblies (Body Components)</b>				<b>Fasteners</b>			
1	8960-2	Ignition Key (1 Set)	1		F002	10-24 Keps Nut	4
2	8960-15	Ignition Switch (with Keys) (Includes Items # 1, 20 & F349)	1		F025	10-24 x 3/8 PPHMS	3
3	5940-3	Ignition Switch Cover	1		F026	10-24 x 1/2 PPHMS	1
4	5975-3	Cable Tie (50# x 7")	3		F349	Washer .835 ID 1.122 OD, SS	1
5	5983	Power Lead Wire	1	* Service Part Only			
6	5975-5	Wire Clip, Self-Mount	1	<b>NOTE:</b> Refer to <b>ELECTRICAL CONNECTORS</b> , Page 40 for identification of all Electrical Wiring Service Parts.			
7	5941-5	Safety Switch (NO)	1				
8	7203-6	Riser Plate	1				
9	5977-6	Grommet (1 x 1-1/4)	1				
10	6940-10	Jumper Wire	1				
11	8996-4	Red Indicator Lens (Includes Item # 12)	1				
12	8996-3	Indicator Bulb (Replacement for P/N 8996)	*				
13	8996-2	Red Indicator Light Assembly (Includes Items # 11 & 12)	1				
14	5991-1	Hourmeter Power Lead Wire	1				
15	8990-1	Hourmeter (SenDec)	1				
16	5991-2	Hourmeter Ground Wire	1				
17	6941	Relay Switch (30/40 Amp)	2				
18	7941-5	Circuit Breaker (7 Amp) (Includes Item # 19)	1				
19	7941-3	Boot, Circuit Breaker	1				
20	7854	Plastic Tip / Red	1				



# ELECTRICAL ASSEMBLIES (BODY COMPONENTS)

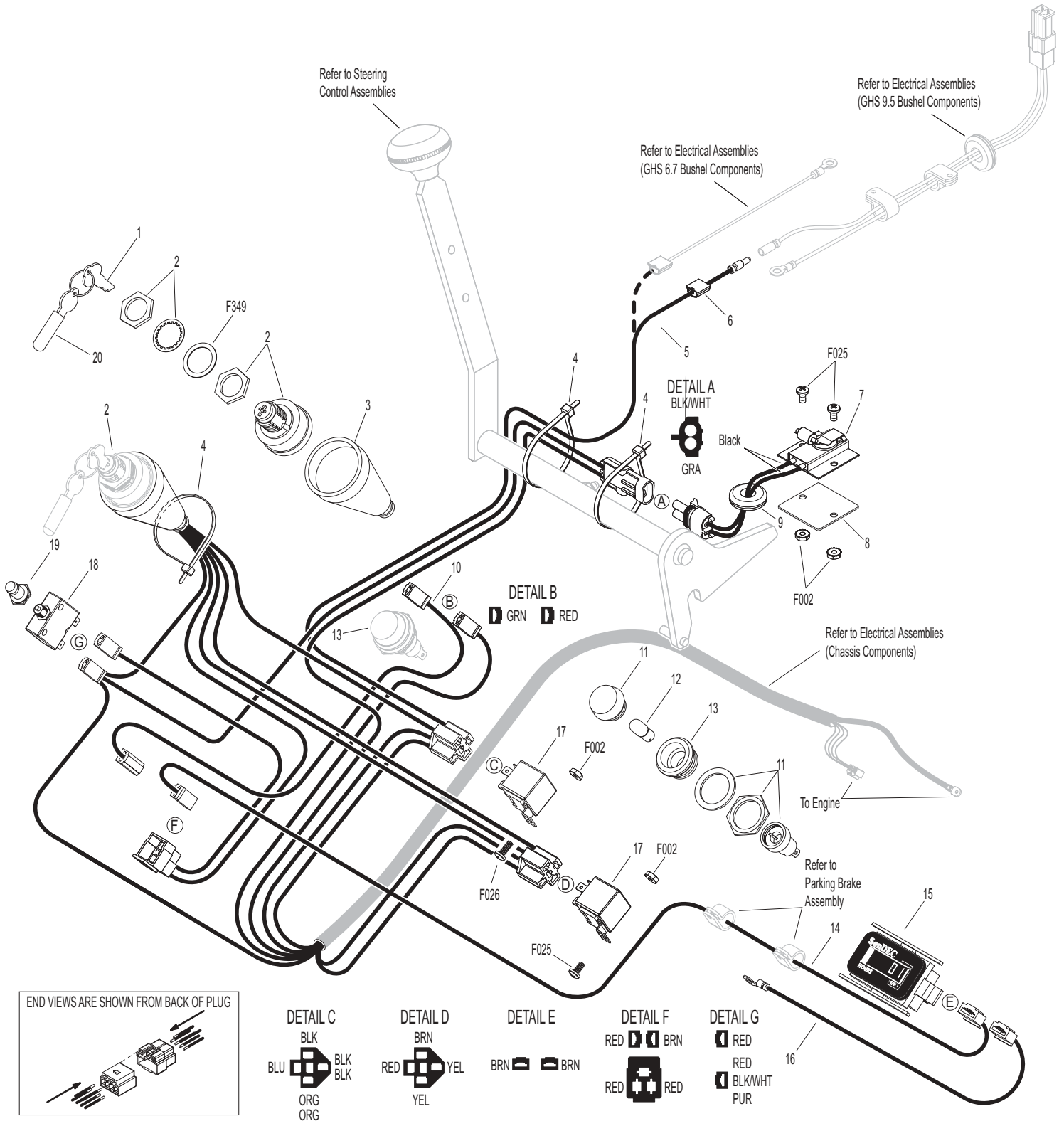

Effective Date 11-01-04

Use only genuine **Walker®** replacement parts.

# ELECTRICAL ASSEMBLIES (GHS 6.7 BUSHEL COMPONENTS)

ITEM NO.	PART NO.	DESCRIPTION	NO. REQ'D	ITEM NO.	PART NO.	DESCRIPTION	NO. REQ'D
<b>Horn &amp; Powerfil® Wiring Assemblies</b>				<b>Fasteners</b>			
1	5599	Pigtail Wire Set, Horn	1	F002		10-24 Keps Nut	11
2	5857	Wire Clamp (1/8 J-Clip)	1	F025		10-24 x 3/8 PPHMS	1
3	5975-3	Cable Tie (50# x 7")	2	F037		10-24 x 5/8 PTH Screw	1
4	5536-2	Horn, Full Signal	*	F085		3/16 Rivet Backup Washer	1
5	5984	Electric Contact Spring	2	F086		#10 SAE Washer	1
6	5982-2	Insulator Bushing	1	F129		10-24 x 1/2 PTHMS	3
7	5982-1	Insulator Washer (2")	1	F144		4-40 x 1/4 PPHMS	1
8	5985-2	Power Lead Wire (6.7)	1	F145		4-40 Keps Nut	1
9	5988-1	Conduit Assembly, Powerfil®	1	F147		10-24 x 1/2 PPHMS SS	3
	5988-4	Powerfil® Tube & Wire Assembly (Includes Item # 8)	*	F148		10-24 x 3/8 PPHMS SS	3
<b>Grass-Pak® Switch Assembly</b>				* Service Part Only			
10	5833	Cable Clamp (1/4)	2	<b>NOTE:</b> Refer to <b>ELECTRICAL CONNECTORS</b> , Page 40 for identification of all Electrical Wiring Service Parts.			
11	5980-3	Wire, Grass-Pak® Switch	1				
12	5592-11	Liquid Tight Plug	1				
13	5592-10	Grass-Pak® Switch Module	1				
	5592-4	Grass-Pak® Switch Assembly (Includes Items # 3 & 10-14)	*				
14	5594-5	Vane Assembly, Grass-Pak® Switch (Includes Items # F144 & F145)	1				

# ELECTRICAL ASSEMBLIES (GHS 6.7 BUSHEL COMPONENTS)

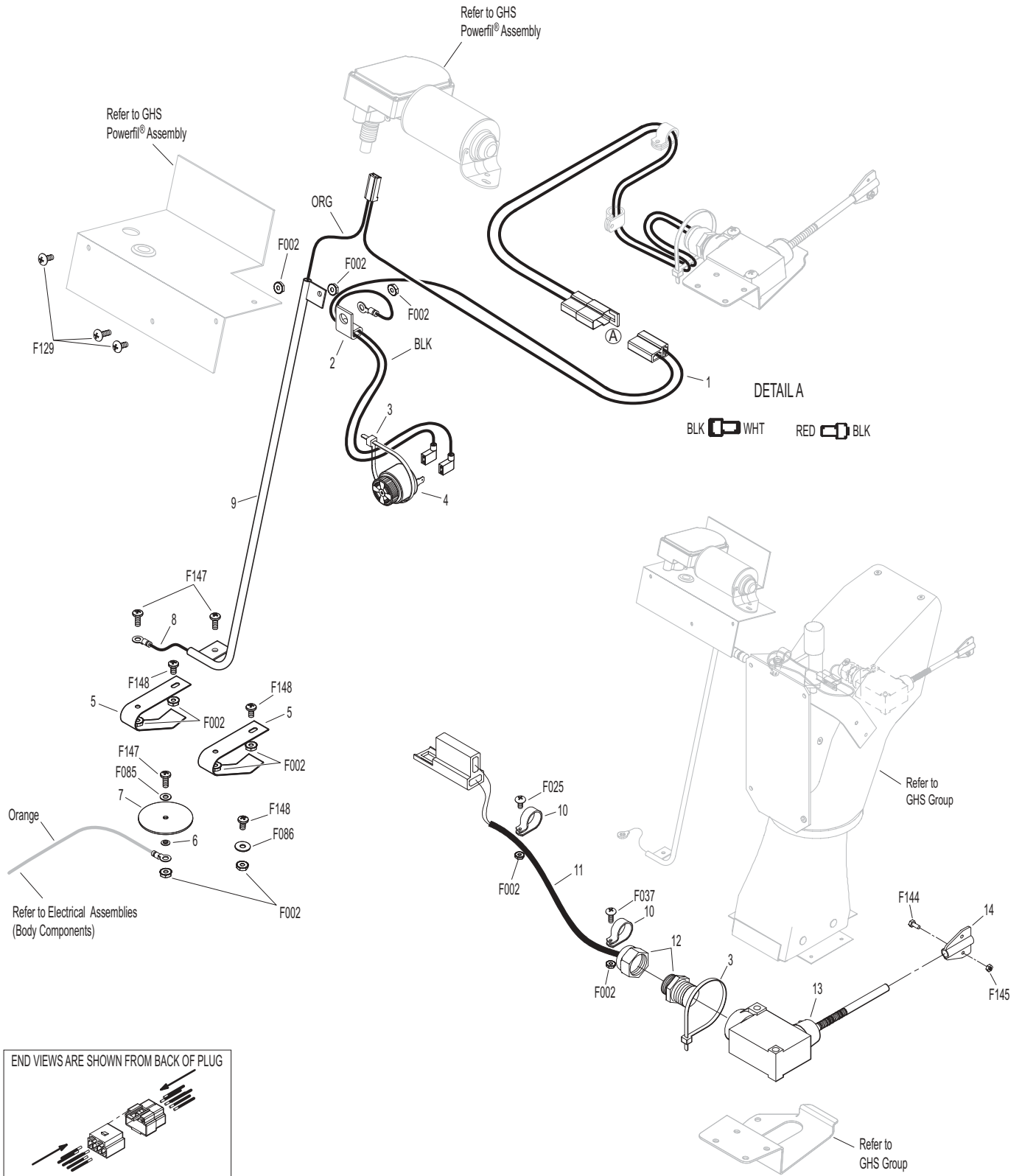

Effective Date 11-01-04

Use only genuine **Walker®** replacement parts.

# ELECTRICAL ASSEMBLIES (GHS 9.5 BUSHEL COMPONENTS)

ITEM NO.	PART NO.	DESCRIPTION	NO. REQ'D	ITEM NO.	PART NO.	DESCRIPTION	NO. REQ'D
<b>Horn &amp; Harness Channel Assemblies</b>				<b>Fasteners</b>			
1	5976	Grommet (3/8 x 11/16)	2	F002		10-24 Keps Nut	10
2	5975-3	Cable Tie (50# x 7")	2	F025		10-24 x 3/8 PPHMS	1
3	5536-2	Horn, Full Signal	*	F037		10-24 x 5/8 PTH Screw	3
4	8117	9.5 Wire Harness Channel	1	F079		A/A66D Aluminum Pop Rivet	4
<b>Harness &amp; Grass-Pak® Switch Assemblies</b>				F085		3/16 Rivet Backup Washer	4
5	5833	Cable Clamp (1/4)	4	F129		10-24 x 1/2 PTHMS	6
6	5977-2	Grommet, Cut (1/8 x 3/8)	2	F144		4-40 x 1/4 PPHMS	1
7	8950-1	Extension Wire	1	F145		4-40 Keps Nut	1
8	7835	Frame Clip (3/16)	2	* Service Part Only			
9	7834	Nylon Clamp (1/4)	4	<b>NOTE:</b> Refer to <b>ELECTRICAL CONNECTORS</b> , Page 40 for identification of all Electrical Wiring Service Parts.			
10	8950	9.5 Wire Harness	1				
11	5980-3	Wire, Grass-Pak® Switch	1				
12	5592-11	Liquid Tight Plug	1				
13	5592-10	Grass-Pak® Switch Module	1				
	5592-4	Grass-Pak® Switch Assembly (Includes Items # 2, 5 & 11-14)	*				
14	5594-5	Vane Assembly, Grass-Pak® Switch (Includes Items # F144 & F145)	1				

# ELECTRICAL ASSEMBLIES (GHS 9.5 BUSHEL COMPONENTS)

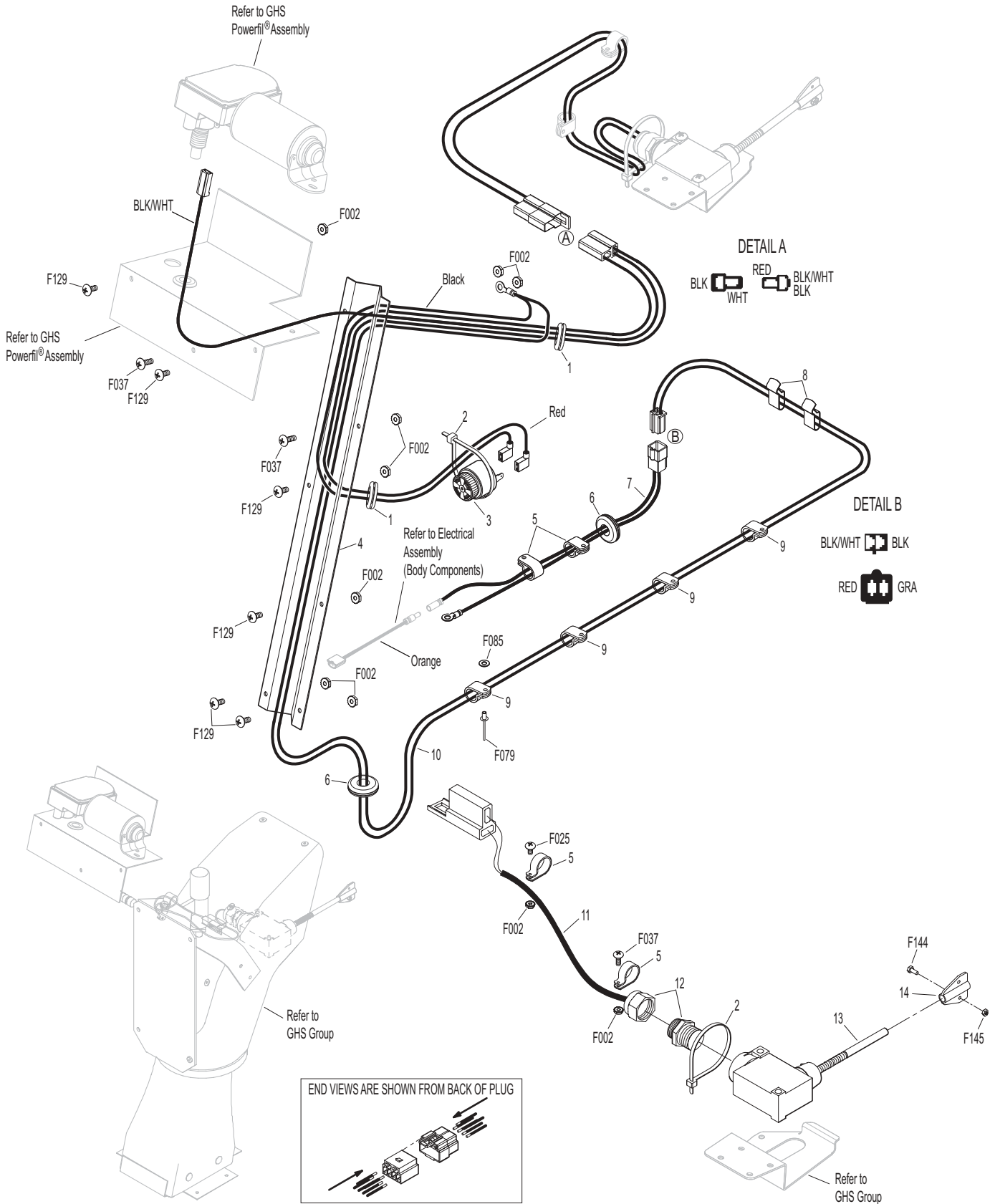

# ELECTRICAL CONNECTORS

ITEM NO.	PART NO.	DESCRIPTION	NO. REQ'D	ITEM NO.	PART NO.	DESCRIPTION	NO. REQ'D
<b>Electrical Wiring Service Parts</b>				29	7942-1	2-Way Locking Connector, Female	*
1	5996-1	16-14 GA Butt Connector	*	30	7942-2	2-Way Connector, Male	*
2	5996-11	12-10 GA Butt Connector	*	31	7942-3	2-Way Connector, Female	*
3	7942-14	16-14 GA Shrink Connector	*	32	7942-10	2-Way Locking Connector, Male	*
4	7942-13	12-10 GA Shrink Connector	*	33	5940-8	3-Way Connector, Male	*
5	5995-1	Wire Terminal Adapter	*	34	7942-9	3-Way Connector, Male	*
6	5996-4	16-14 GA Bullet Conn., Male	*	35	8944	3-Way Locking Connector, Male	*
7	5996-5	16-14 GA Bullet Conn., Female	*	36	8944-1	3-Way Locking Connector, Female	*
8	5940-4	16-14 GA Spg. Loaded Term., Female	*	37	7942-11	4-Way Connector, Male	*
9	5940-7	Wire Clip, Female	*	38	7942-12	4-Way Connector, Female	*
10	5996	1/4 x 16-14 GA QKS Term., Female	*	39	7942-5	5-Way Connector, Male	*
11	5996-2	3/16 x 22-18 GA QKS Term., Female	*	40	5940-2	5-Way Connector, Male	*
12	7996	3/16 x 16-14 GA QKS Term., Female	*	41	8942-1	5-Way Connector, Female	*
13	5940-5	16-14 GA Spg. Loaded Term., Male	*	42	7942-6	6-Way Connector, Male	*
14	5996-0	1/4 x 22-18 GA QKS Term., Male	*	43	7942-7	6-Way Connector, Male	*
15	5996-18	16-14 GA Ring Term. (#8) Nylon Insulated	*	44	7942-8	8-Way Connector, Male	*
16	7996-1	1/4 x 16-14 GA QKS Term., Male	*	45	8942-2	8-Way Connector, Female	*
17	5996-8	6 GA Ring Lug (5/16)	*	46	8942-3	5-Way Connector, Male	*
18	5996-9	22-18 GA Ring Term., #10	*	47	5940-9	3-Way Connector (M)	*
19	5996-10	16-14 GA Ring Term. (5/16)	*	48	7942-15	6-Way Connector (Female)	*
20	5996-12	12-10 GA Ring Term. (5/16)	*	49	7940-3	Packard Plug (Male)	*
21	5996-13	16-14 GA Ring Term., # 10	*	50	7940-4	Packard Plug (Female)	*
22	5996-15	12-10 GA Ring Term. (1/2)	*	* Service Part Only			
23	5996-16	6 GA Ring Terminal (1/4)	*	<b>NOTE:</b> Not all Electrical Connectors are used with all assemblies.			
24	5996-17	16-14 GA Ring Term. (1/4)	*	<b>NOTE:</b> Refer to <b>ELECTRICAL ASSEMBLIES</b> , Pages 32-39 for locations of Wiring Harness, Electrical Components and of all Electrical Wiring Service Parts.			
25	5996-20	12-10 GA Ring Term. (1/4)	*				
26	5996-21	12-10 GA Ring Term., #10	*				
27	7942-4	Single Connector, Male	*				
28	8942	2-Way Connector, Male	*				

# ELECTRICAL CONNECTORS

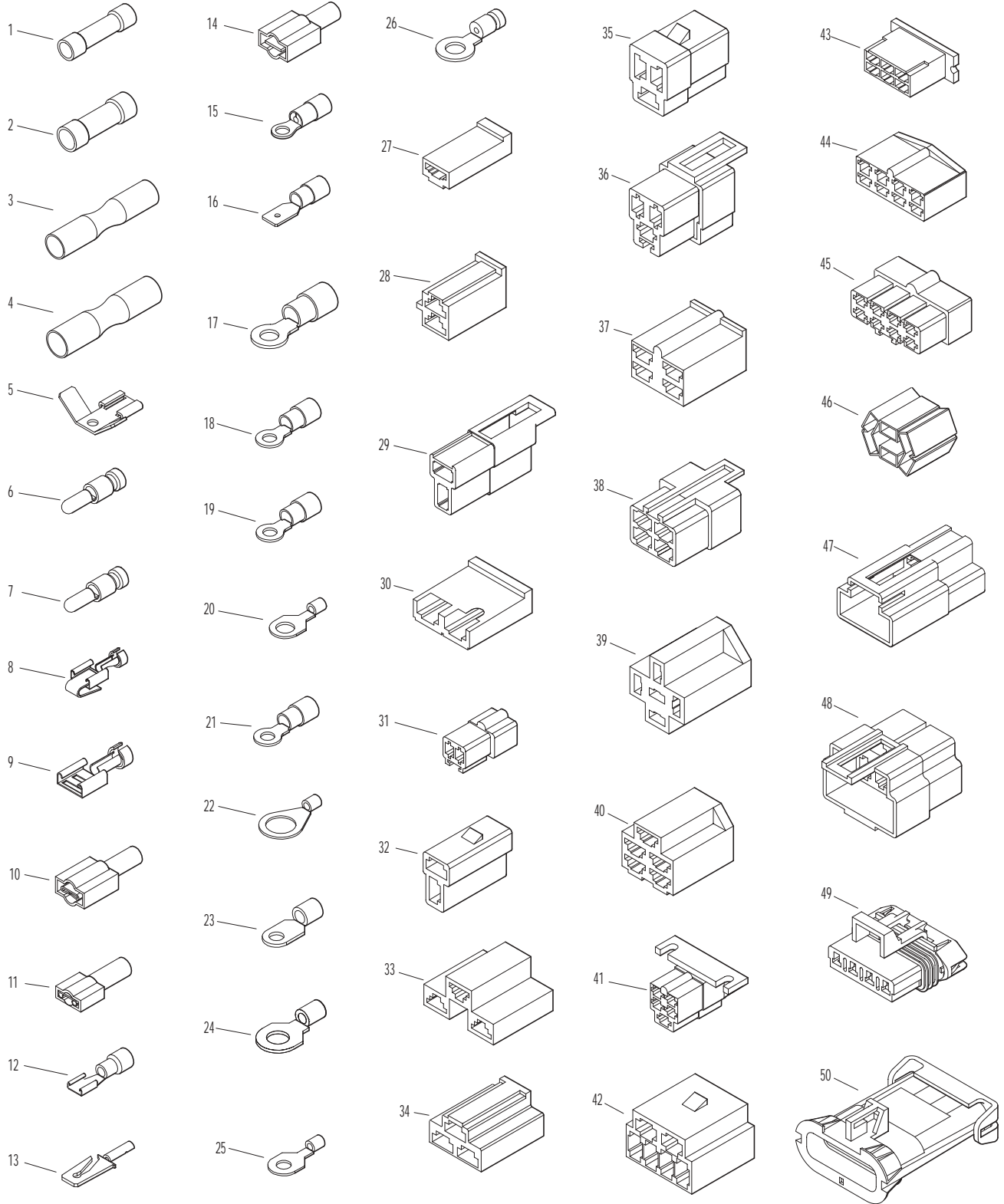

# ARMREST KIT / TOUCH-UP PAINT

ITEM NO.	PART NO.	DESCRIPTION	NO. REQ'D
----------	----------	-------------	-----------

**Kit 5885 Armrest Option / Kit**

Includes Items # 1-5, fasteners listed and instructions. May be ordered as a dealer-installed option. Contact your Walker dealer.

1	5886-1	Armrest, RH	1
2	5886-6	Cover Plate, RH	1
3	5887	Mounting Bracket	1
4	5886-5	Cover Plate, LH	1
5	5886-2	Armrest, LH	1
	5888	Armrest Hardware Kit (Includes Items # F305, F306, F307 & F308)	*

ITEM NO.	PART NO.	DESCRIPTION	NO. REQ'D
----------	----------	-------------	-----------

**Touch-Up Paint**

6	5866	Touch-Up Paint, Yellow (12 oz. Aerosol)	
7	5867	Touch-Up Paint, Grey (12 oz. Aerosol)	

**Fasteners**

	F305	1/4-20 x 3/8 SH Cap Screw	2
	F306	3/8-16 x 3/4 Hex Bolt	4
	F307	#10 x 5/8 PPHST Screw	2
	F308	1-1/4 x 1-5/8 Wave Spring Washer	2

\* Service Part Only





## COMFORT SEAT / ARMREST KIT

ITEM NO.	PART NO.	DESCRIPTION	NO. REQ'D
----------	----------	-------------	-----------

**Kit 6103-5 Comfort Seat Kit (Cordura)**

Includes Items # 1, 6, fasteners listed (except as indicated; refer to **NOTE**) and instructions. May be ordered as a factory-installed option or as a kit for dealer installation. Contact your Walker dealer.

1	6103-5	Comfort Seat	1
2	7203	Seat Spring Plate	1
3	7223	Compression Spring (1/2 x 1)	2
4	7846	Rubber Washer (3/8 x 1-1/4 x 1/8)	2
5	7204	Shoulder Bolt, Seat Mount	2
6	7203-6	Riser Plate, Seat Switch	*
7	7845	Rubber Bumper (1.375 x .63)	2
8	7440-5	Shock Mount (1-1/4 x 2)	2

ITEM NO.	PART NO.	DESCRIPTION	NO. REQ'D
----------	----------	-------------	-----------

**Kit 6103-17 Armrest Option / Kit**

Includes Items # 9, 10 and instructions. Item # 9 is the **Right** side armrest only. Item # 10 is the **Left** side armrest only. Sold only as a complete set and may be ordered together as a kit for dealer installation. Contact your Walker dealer.

9	6103-42	Armrest, RH / Cordura	1
10	6103-41	Armrest, LH / Cordura	1

**Fasteners**

F009	5/16-18 Whiz Locknut	2
F026	10-24 x 1/2 PPHMS	2
F227	3/8 x 1-1/4 x 1/8 Plastic Washer	2

\* Only one Riser Plate is included with kit. One is reused from Seat Switch. Refer to **ELECTRICAL ASSEMBLIES (BODY COMPONENTS)**, Page 34.

**NOTE:** Reuse Items # 3-8, F009 and F227 from Seat Assembly. Refer to **BODY / CHASSIS ASSEMBLY (GHS MODELS)**, Page 4.

# COMFORT SEAT / ARMREST KIT

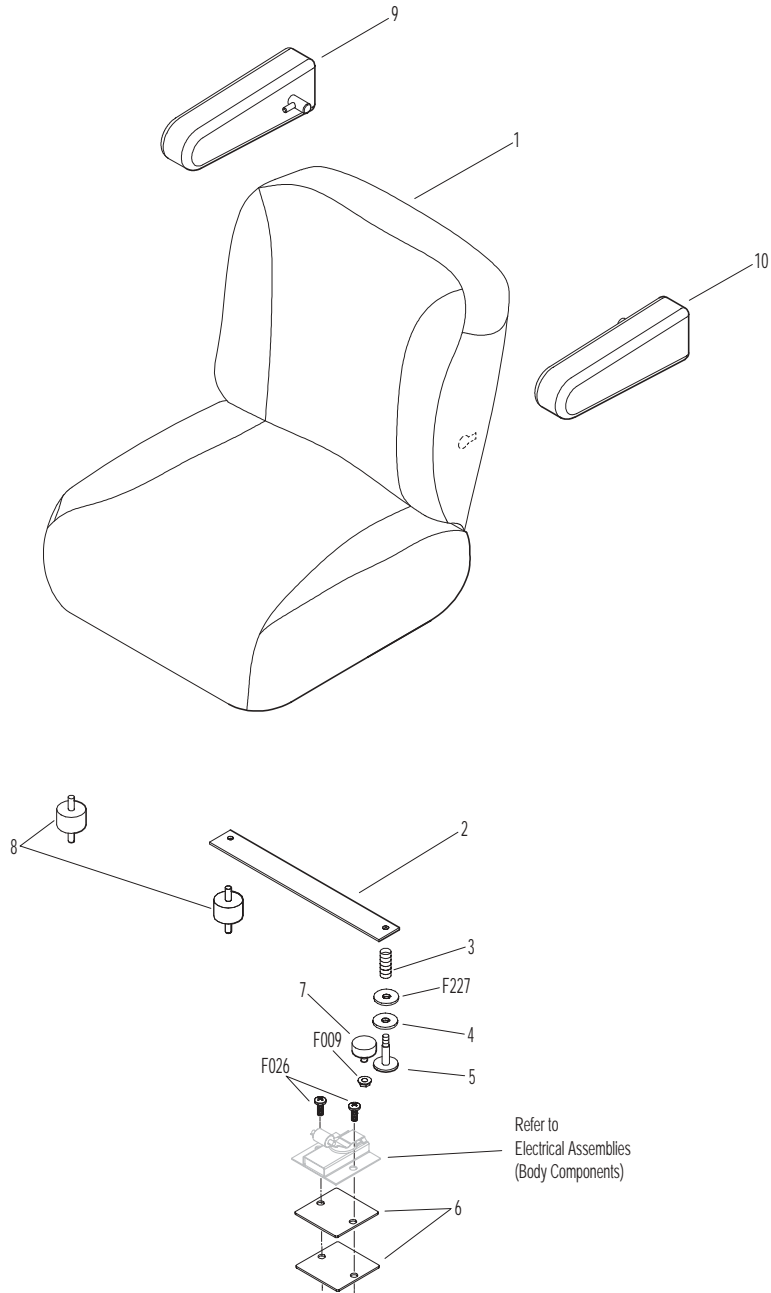

# SUSPENSION SEAT KIT

ITEM NO.	PART NO.	DESCRIPTION	NO. REQ'D
----------	----------	-------------	-----------

**Kit 6103-9 Armrest Kit**

Includes Items # 1-6 and instructions. May be ordered as a kit for dealer installation. Contact your Walker dealer.

1	6103-92	Armrest / RH, SS	1
2	NS	5/8 Nut Cover	4
3	NS	7/16-20 x 13/4 HHCS	4
4	NS	3/8 SAE Washer	4
5	NS	Bushing, 3/4 x 3/4	4
6	6103-91	Armrest / LH, SS	1

**Kit 6103-25 Suspension Seat Option / Kit**

Includes Items # 7-9, 11-13, 18, 21, fasteners listed (except as indicated; refer to **NOTE**) and instructions. May be ordered as a factory-installed option or as a kit for dealer installation. Contact your Walker dealer.

7	6103-11	Suspension Seat	1
8	5941-5	Safety Switch (NO)	*
9	6103-33	Seat Mount Plate / LH, SS	1
10	7223	Compression Spring (1/2 x 1)	2
11	5975-3	Cable Tie (50# x 7")	2
12	5975-1	Cable Tie (18# x 3-3/4")	1
13	6103-23	Wire Harness, SS	1
14	7846	Rubber Washer (3/8 x 1-1/4 x 1/8)	2
15	7204	Shoulder Bolt, Seat Mount	2
16	5453-20	Steering Lever Handle +1" Adj. / SS	2
17	5977-6	Grommet (1 x 1-1/4)	2
18	5841	Retainer Washer (3/8 x 1-1/4)	2
19	7845	Rubber Bumper (1.375 x 0.63)	2
20	7440-5	Shock Mount (1-1/4 x 2)	2
21	6103-34	Seat Mount Plate / RH, SS	1

ITEM NO.	PART NO.	DESCRIPTION	NO. REQ'D
----------	----------	-------------	-----------

**Fasteners**

F002	10-24 Keps Nut	4
F009	5/16-18 Whiz Locknut	6
F026	10-24 x 1/2 PPHMS	4
F168	5/16 Split Lock Washer	4
F227	3/8 x 1-1/4 x 1/8 Washer (Plastic)	2
F357	M8 x 16 Hex Bolt	2
F358	M8 x 25 Hex Bolt	2

\* Only one Safety Switch is included with kit. One is reused from Electrical Assembly. Refer to **ELECTRICAL ASSEMBLIES (BODY COMPONENTS)**, Page 34.

**NOTE:** Reuse Items # 10, 14, 15, 17, 19, two (2) each of Items # F002, F009 and F026, and Item # F227 from Seat Assembly. Refer to **BODY / CHASSIS ASSEMBLY (GHS MODELS)**, Page 4.

# SUSPENSION SEAT KIT

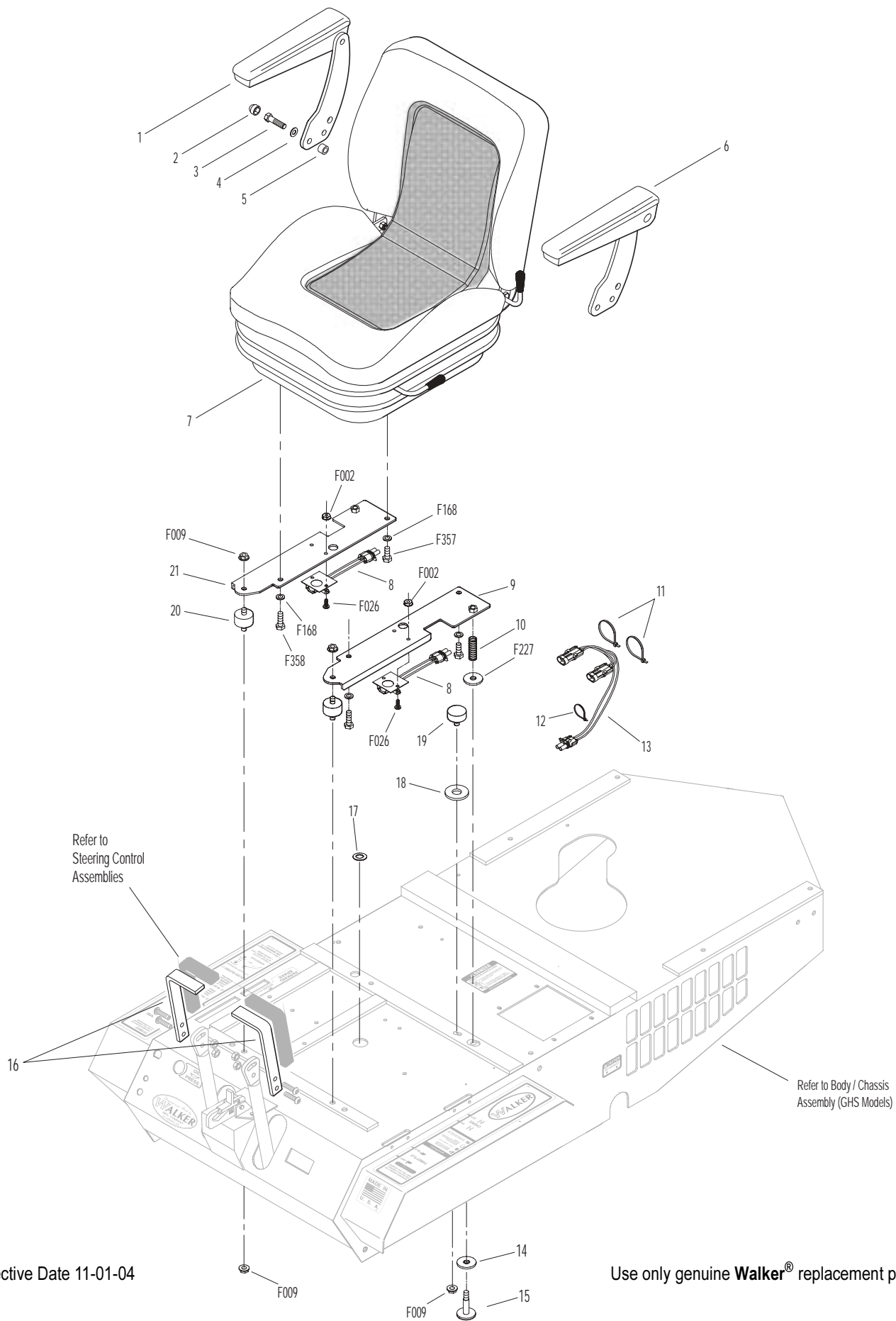

Effective Date 11-01-04

Use only genuine Walker® replacement parts.

# LIGHT KIT

ITEM NO.	PART NO.	DESCRIPTION	NO. REQ'D	ITEM NO.	PART NO.	DESCRIPTION	NO. REQ'D
<b>Kit 5989 Light Option / Kit</b> Includes Items # 1-15, fasteners listed and instructions. May be ordered as a kit for dealer installation. Contact your Walker dealer.				<b>Fasteners</b>			
1	7989-2	Light Assembly (Halogen) (Includes Bulb)	2	F009		5/16-18 Whiz Locknut	2
	7989-6	Bulb Replacement (Halogen)	*	F052		5/16 Ext. Star Lock Washer	2
2	7989-3	Wire Harness Extension	2	F091		5/16-18 x 5/8 Hex Bolt	2
3	7834-1	Half U-Wire Clip	4	* Service Part Only			
4	5996-4	16-14 GA Bullet Cntr. (M)	2	<b>NOTE:</b> Upon installation of kit, Item # 8 replaces P/N 5989-4 (Dome Plug, 3/8), and Item # F091 replaces P/N 5989-3 (Dome Plug, 5/16). Dome Plugs are not shown here. Refer to <b>BODY / CHASSIS ASSEMBLY (GHS MODELS)</b> , Page 4.			
5	5996-5	16-14 GA Bullet Cntr. (F)	2	<b>NOTE:</b> Refer to <b>ELECTRICAL CONNECTORS</b> , Page 40 for identification of all Electrical Wiring Service Parts.			
6	7992	Mount Bracket, Lights	1				
7	7995-4	Power Lead Wire Assembly (Includes Items # 5, 10, 13 & 14)	1				
8	5977-1	Grommet (1/8 x 3/8)	2				
9	5975-5	Wire Clip, Self-Mount	3				
10	5975-1	Cable Tie (18# x 3-3/4")	1				
11	5995	Toggle Switch (Off-On)	1				
12	5995-2	Switch Boot	1				
13	5996-1	16-14 GA Butt Connector	*				
14	5996	1/4 x 16-14 GA QDF Terminal	*				
15	6940-10	Jumper Wire	1				

# LIGHT KIT

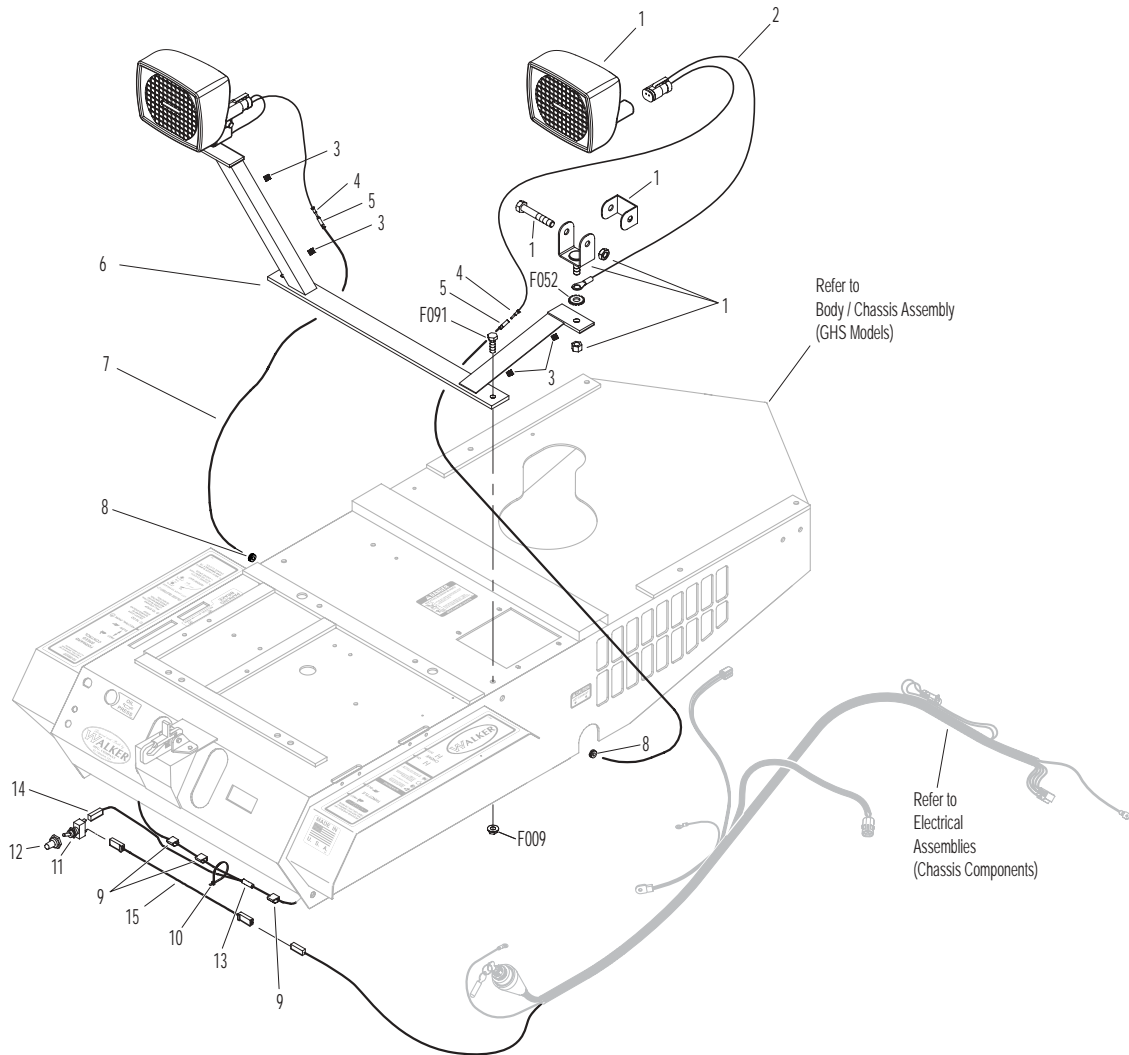

# BLOWER LOCKOUT KIT / CASE-HARDENED BLOWER

ITEM NO.	PART NO.	DESCRIPTION	NO. REQ'D
----------	----------	-------------	-----------

**Kit 6541 Blower Lockout Kit**

Includes Items # 1-7, fasteners listed and instructions. May be ordered as a kit for dealer installation. Contact your Walker dealer.

1	7854	Plastic Tip, Red	*
2	6541-2	Blower Lockout Rod (Includes Item #1)	1
3	6541-1	Blower Lockout Latch	1
4	5280	Clevis (1/4)	1
5	5281-5	Clevis Pin (1/4 x 0.80)	1
6	6541-3	Blower Lockout Pivot Arm	1
7	6541-4	Blower Lockout Belt Guide	1

ITEM NO.	PART NO.	DESCRIPTION	NO. REQ'D
----------	----------	-------------	-----------

**Kit 6542-15 Case Hardened Blower Option**

Includes Items # 8-13, fasteners listed and instructions. May be ordered as a kit for dealer installation. Contact your Walker dealer.

8	5268	Bearing W/Collar (3/4)	2
9	6543-15	Case Hardened Blower Housing	1
10	6545-15	Case Hardened Blower Wheel	1
11	6525-2	Faceplate (10" Blower)	1
12	6526	Intake Tube (6-1/2 x 2-1/2)	1
13	6542-50	Decal, "H" (5/8)	1

**Fasteners**

F003	1/4-28 Hex Nut	1
F004	1/4-20 Keps Nut	7
F032	1/4-20 x 3/4 Hex Bolt	1
F074	1/4-20 x 3/8 Set Screw	2
F091	5/16-18 x 5/8 Hex Bolt	1
F186	5/64 x 1/2 Cotter Pin	1
F325	1/4-20 x 3 Hex Bolt	1

\* Service Part Only



# BLOWER LOCKOUT KIT / CASE-HARDENED BLOWER

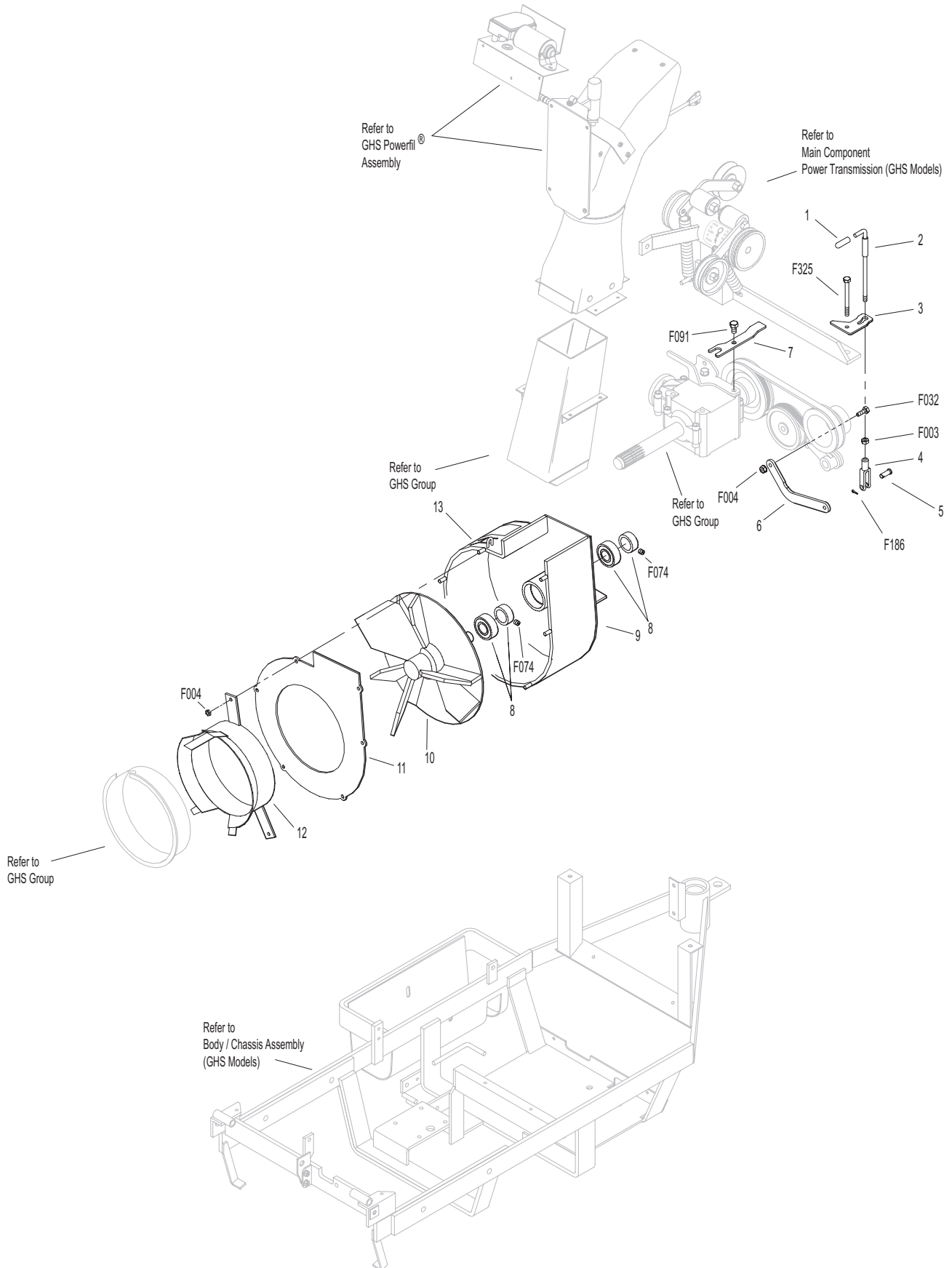

## NO CATCH DEFLECTOR KIT (6.7 BUSHEL)

ITEM NO.	PART NO.	DESCRIPTION	NO. REQ'D	ITEM NO.	PART NO.	DESCRIPTION	NO. REQ'D
<b>Kit 5500 No Catch Deflector Option / Kit (6.7 Bushel)</b> Includes Items # 1-10, fasteners listed and instructions. May be ordered as a kit for dealer installation. Contact your Walker dealer.				<b>Fasteners</b>			
1	8500-5	Side Bracket	2	F002		10-24 Keps Nut	4
2	8787-2	Knob (1/4-20) Threaded Insert	1	F030		1/4-20 x 1/2 PPH Bolt	1
3	5500	No Catch Deflector Kit, 6.7 (Includes Items # 4 & F340)	1	F128		10-24 x 3/8 PTHMS	4
4	5726-10	Hinge (2 x 8)	2	F146		1/4-20 Jam Nut	1
5	8500-8	Decal, No Catch Deflector	1	F333		1/4-20 x 3/4 PTHMS	1
6	8500-6	Spacer Lug	1	F340		Rivet, Aluminum	20
7	5500-8	Wire Assembly, No Catch Deflector (6.7)	1	<b>NOTE:</b> Refer to <b>ELECTRICAL CONNECTORS</b> , Page 40 for identification of all Electrical Wiring Service Parts.			
8	5995	Toggle Switch (Off - On)	1				
9	8500-9	Decal, Off - On	1				
10	5995-2	Switch Boot	1				

# NO CATCH DEFLECTOR KIT (6.7 BUSHEL)

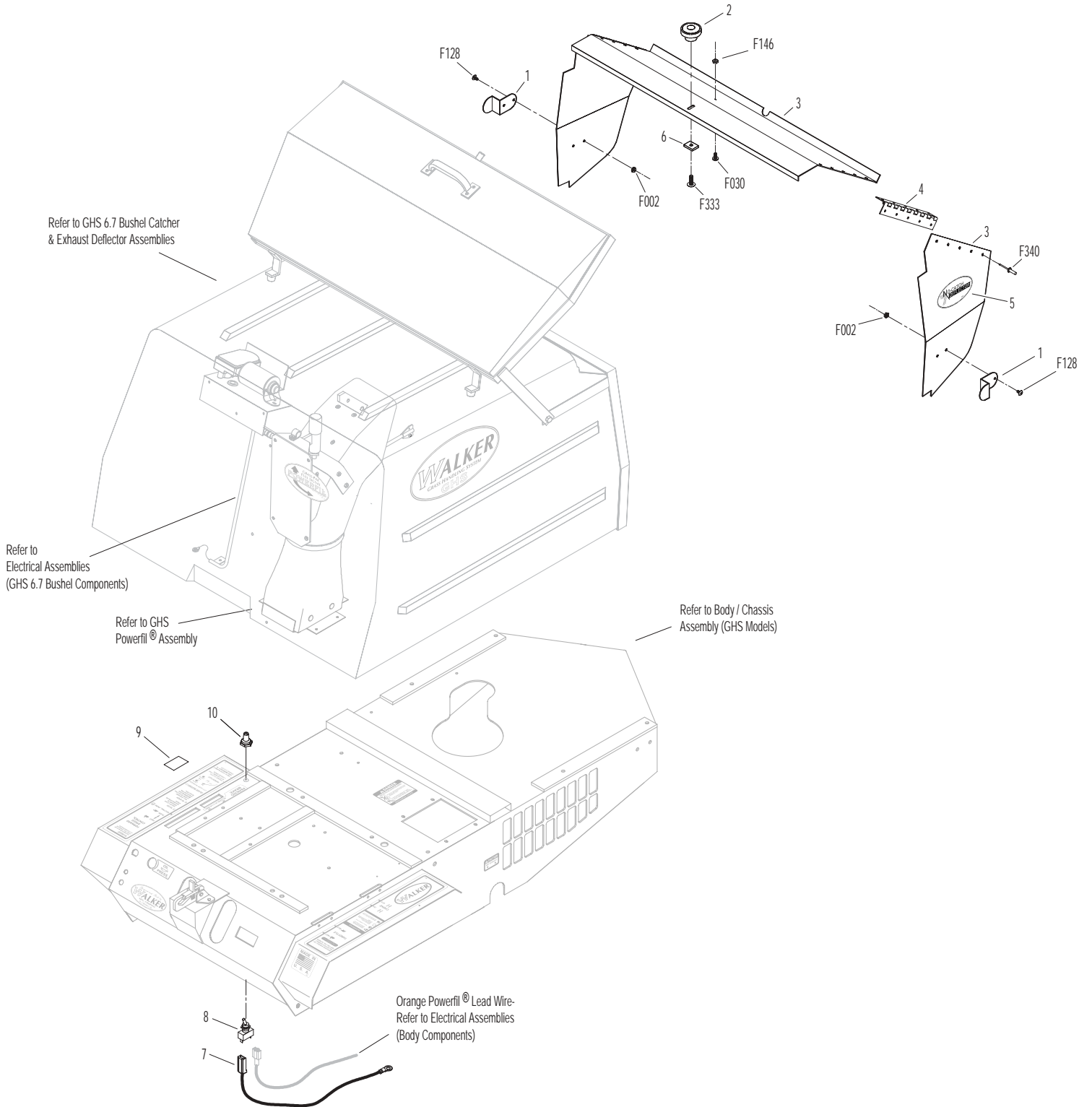

## NO CATCH DEFLECTOR KIT (9.5 BUSHEL)

ITEM NO.	PART NO.	DESCRIPTION	NO. REQ'D	ITEM NO.	PART NO.	DESCRIPTION	NO. REQ'D
<b>Kit 8500 No Catch Deflector Option / Kit (9.5 Bushel)</b> Includes Items # 1-6, fasteners listed and instructions. May be ordered as a kit for dealer installation. Contact your Walker dealer.				<b>Fasteners</b>			
1	8500-5	Side Bracket	2	F002		10-24 Keps Nut	4
2	8500	No-Catch Deflector Kit, 9.5 (Includes Items # 4 & F340)	1	F030		1/4-20 x 1/2 PPH Bolt	1
3	8787-2	Knob (1/4-20) Threaded Insert	1	F128		10-24 x 3/8 PTHMS	4
4	7726-10	Hinge (2 x 11)	2	F146		1/4-20 Jam Nut	1
5	8500-8	Decal, No Catch Deflector	1	F333		1/4-20 x 3/4 PTHMS	1
6	8500-6	Spacer Lug	1	F340		Rivet, Aluminum	24

# NO CATCH DEFLECTOR KIT (9.5 BUSHEL)

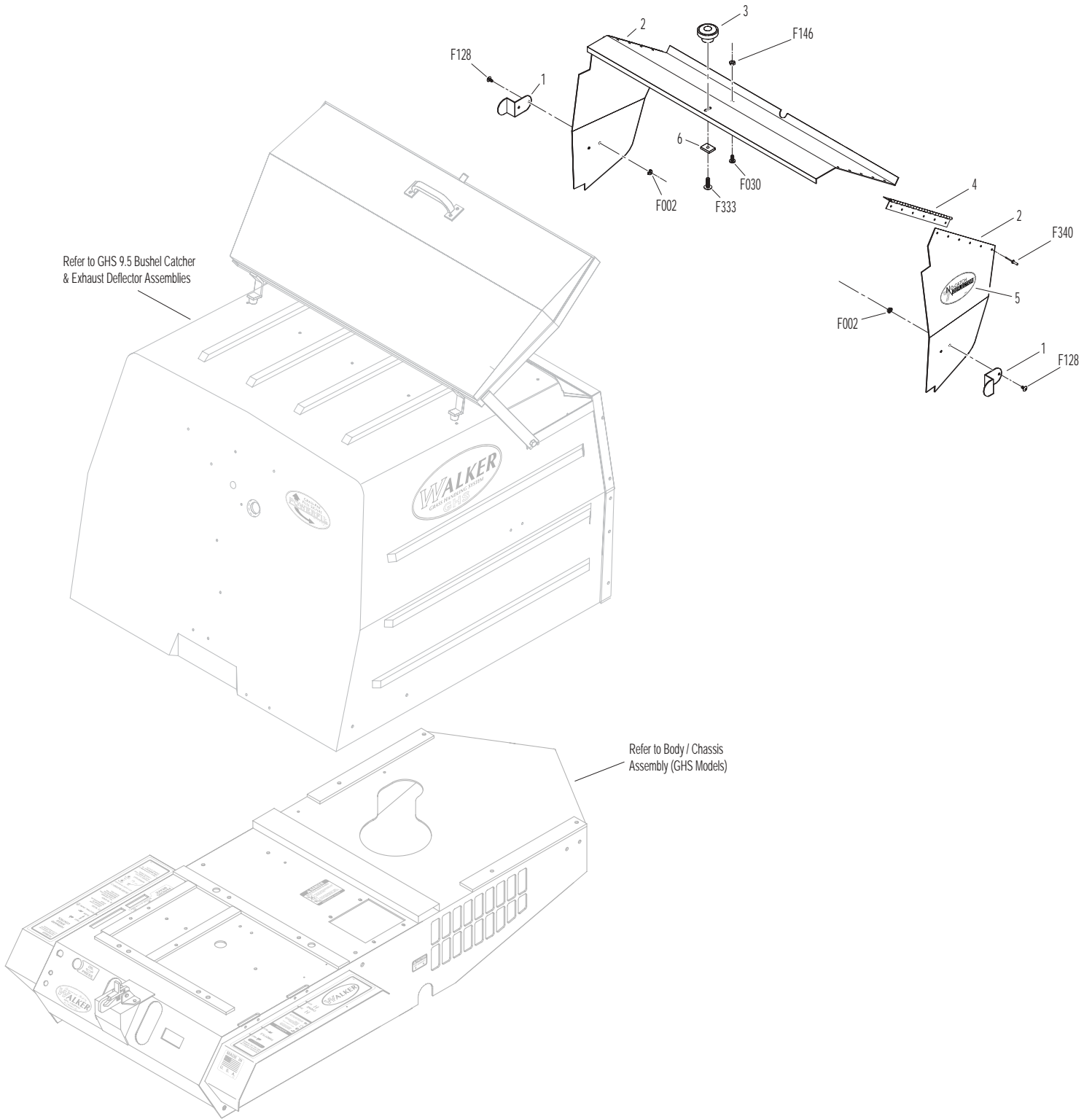

# ALL-TERRAIN TIRE KIT & TIRE CHAIN SETS

ITEM NO.	PART NO.	DESCRIPTION	NO. REQ'D
----------	----------	-------------	-----------

**Kit 8072 All-Terrain Tire Option / Kit**

Includes Items # 1-3 and instructions. May be ordered as a kit for dealer installation. Contact your Walker dealer.

1	8070	All-Terrain Wheel & Tire, RH (18 x 11.00-10)	1
	8070-1	AT Tire (18 x 11.00-10)	*
	8070-2	AT/LP Wheel (10 x 8.5)	*
2	8070-31	Wheel Spacer Plate (1/2)	2
3	8071	All-Terrain Wheel & Tire, LH (18 x 11.00-10)	1

ITEM NO.	PART NO.	DESCRIPTION	NO. REQ'D
----------	----------	-------------	-----------

**Optional Tire Chain Sets**

Includes Items # 2 and 4. Tire Chain Sets are not for use on All-Terrain Tires. Use only with tires listed at Item # 4. Refer also to **BODY / CHASSIS ASSEMBLY (GHS MODELS)**, Page 4.

4	5675-2	Tire Chain Set (18 x 8.50-8) (Includes Item # 2) (For use with Wide Wheel & Tire Assy)	1
	5675	Tire Chain Set (18 x 6.50-8) (Includes Item # 2) (For use with Optional Narrow Drive Tires)	1

**Fasteners**

F157	1/2-20 x 1-1/4 Wheel Lug Bolt	8
------	-------------------------------	---

\* Service Part Only

**NOTE:** Reuse Item # F157 from Wheel & Tire Assembly. Refer to **BODY / CHASSIS ASSEMBLY (GHS MODELS)**, Page 4.

# ALL-TERRAIN TIRE KIT & TIRE CHAIN SETS

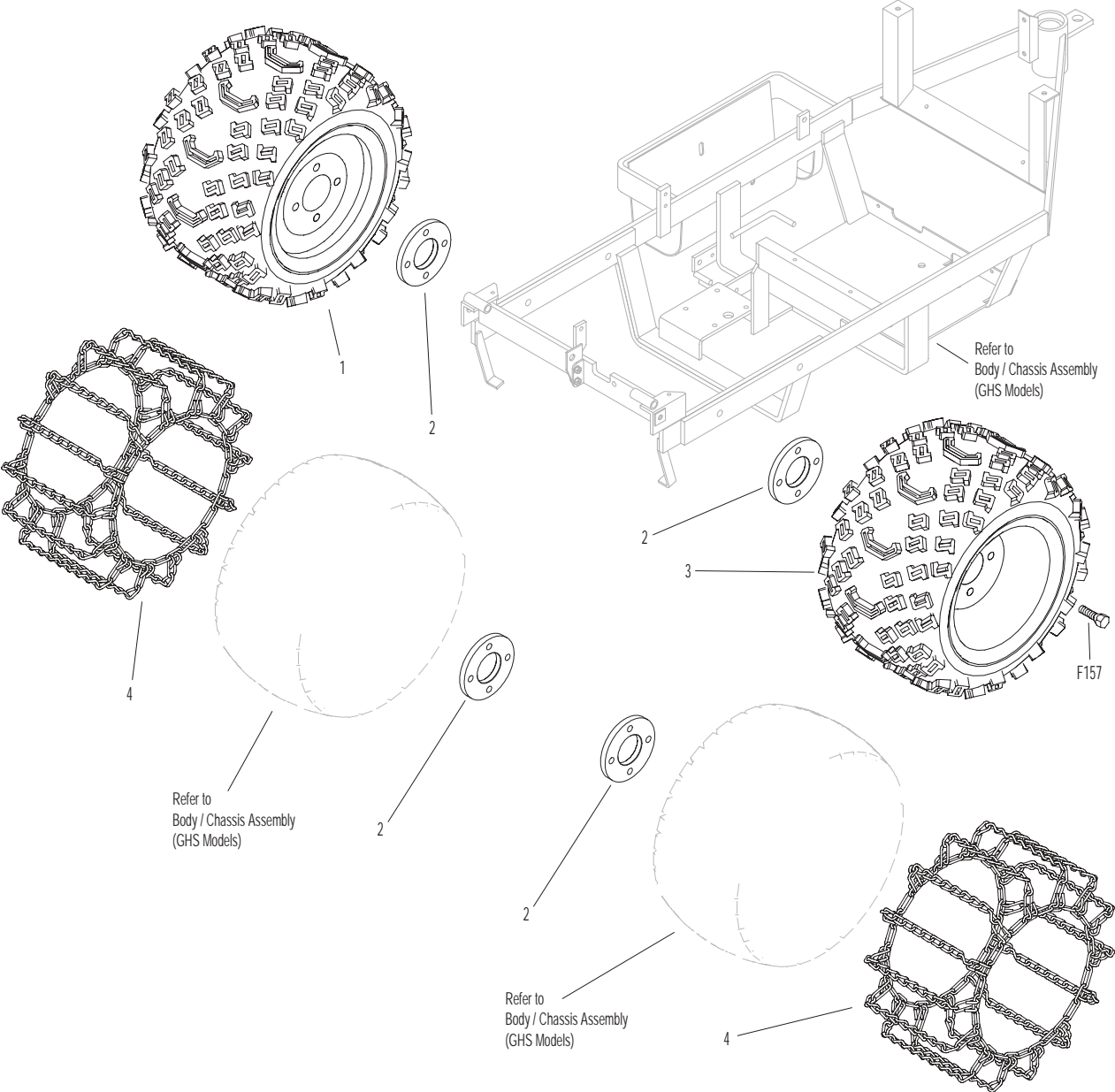





# LUBRICATION POINTS

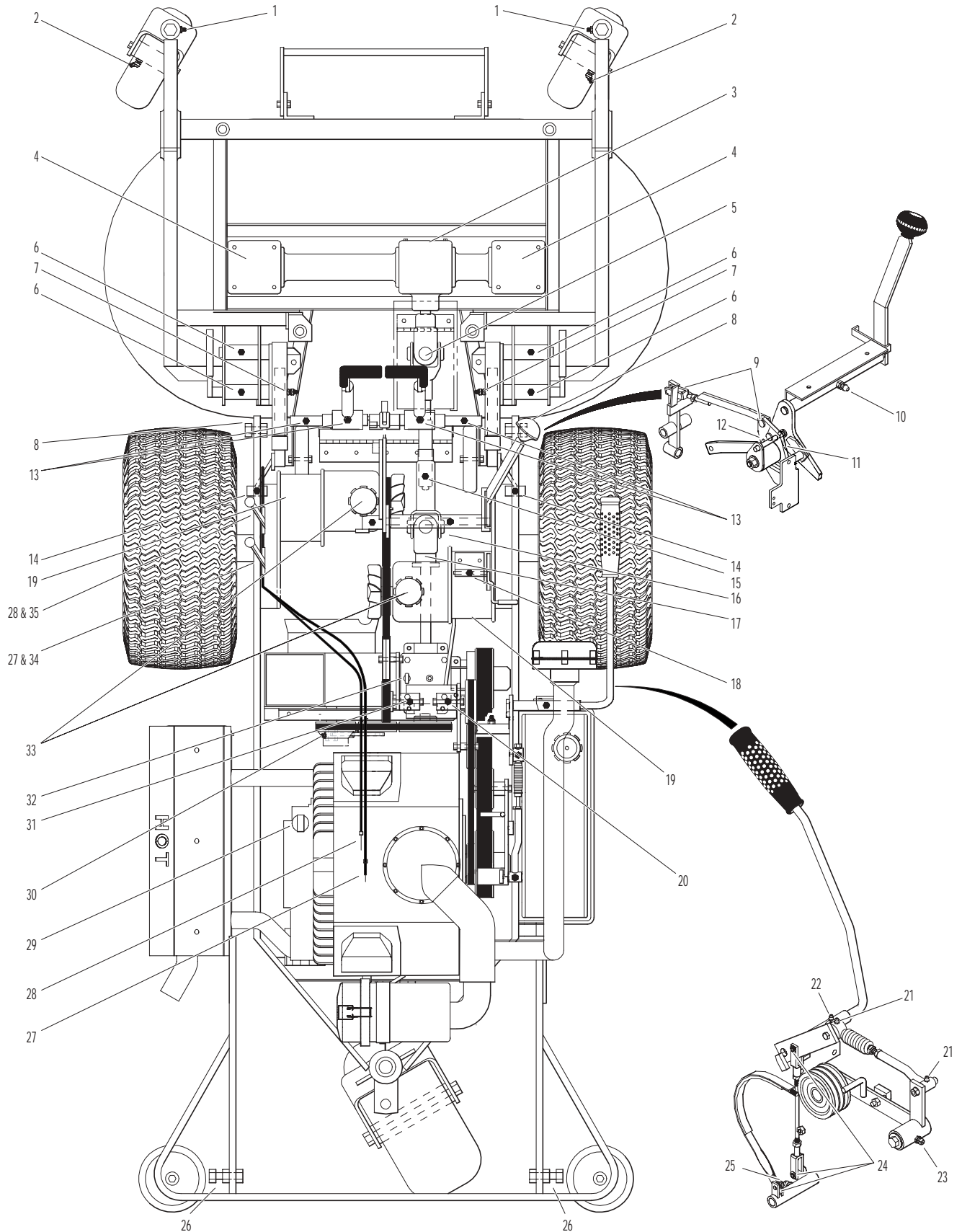

Effective Date 11-01-04

Use only genuine Walker® replacement parts.

# WIRING SCHEMATIC

## WALKER MODEL MC Beginning S/N 2001-49399

IGNITION SWITCH CIRCUITS	
OFF	G + M
START	B + A / S1 + S2
RUN	B + A

S1 = START CIRCUIT  
 S2 = START/ACCESSORY CIRCUIT  
 M = MAGNETO GROUND CIRCUIT  
 B = BATTERY CIRCUIT  
 A = ACCESSORY CIRCUIT  
 G = GROUND CIRCUIT

RELAY - A IGNITION RELAY	
OFF	30 + 87A
START	30 + 87A
PTO ON	OPEN

RELAY - B START RELAY	
OFF	OPEN
START	OPEN
PTO ON	30 + 87

RELAY - C DELAY RELAY	
OFF	30 + 87A
START	OPEN
RUN	OPEN

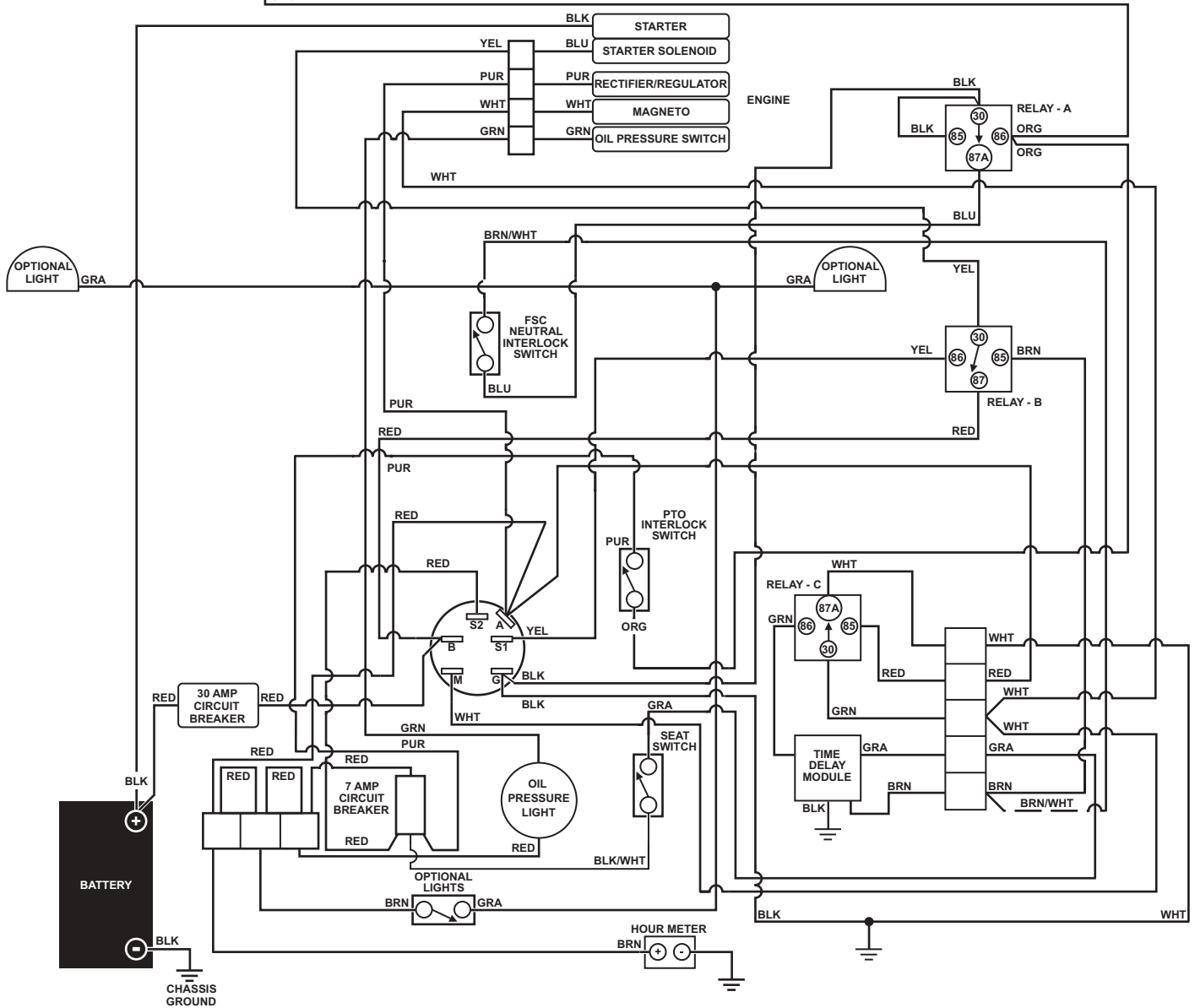
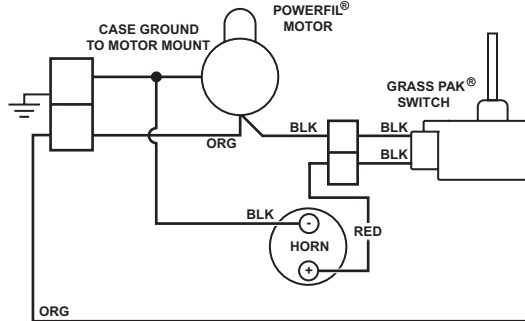

# **LIMITED WARRANTY FOR WALKER COMMERCIAL RIDER MOWER**

## **1. WHAT THIS WARRANTY COVERS, AND FOR HOW LONG:**

Walker Manufacturing company will, at its option, repair or replace, without charge, any part covered by this warranty which is found to be defective in material and/or workmanship within one (1) year\* after date of sale to the original retail purchaser unless the product is used for rental purposes, in which case this warranty is limited to ninety (90) days. At Walker's request, customer will make the defective part available for inspection by Walker and/or return the defective part to Walker, transportation charges prepaid. All parts and components of the Walker Mower are covered by this warranty **except** the following components which are warranted separately by their respective manufacturers:

Kohler Engine  
Kubota Engine  
Kawasaki Engine  
Eaton Hydraulic Transmission  
Peerless Gearboxes  
Battery  
Tires

The available warranties covering these items are furnished with each mower. Walker does not assume any warranty obligation, liability or modification for these items, which are covered exclusively by the stated warranty of the respective manufacturers noted above.

\* An extended three (3) year warranty is offered on the Walker P/N 6200-9 Gear Axle Assembly.

## **2. WHAT THIS WARRANTY DOES NOT COVER:**

- A. This warranty does not cover defects caused by depreciation or damage caused by normal wear, accidents, improper maintenance, improper use or abuse of the product, alterations, or failure to follow the instructions contained in the Owner's Manual for operation and maintenance.
- B. The customer shall pay any charges for making service calls and/or for transporting the mower to and from the place where the inspection and/or warranty work is performed.

## **3. HOW TO OBTAIN SERVICE UNDER THIS WARRANTY:**

Warranty service can be arranged by contacting the dealer where you purchased the mower or by contacting Walker Manufacturing Company, 5925 East Harmony Road, Ft. Collins, CO 80528. Proof of the date of purchase may be required to verify warranty coverage.

## **4. WARRANTY LIMITATION:**

- A. **THERE IS NO OTHER EXPRESS WARRANTY. ANY WARRANTY THAT MAY BE IMPLIED FROM THIS PURCHASE INCLUDING MERCHANTABILITY AND FITNESS FOR A PARTICULAR PURPOSE IS HEREBY LIMITED TO THE DURATION OF THIS WARRANTY AND TO THE EXTENT PERMITTED BY LAW ANY AND ALL IMPLIED WARRANTIES ARE EXCLUDED.** Some states do not allow limitations on how long an implied warranty lasts, so the above limitations may not apply to you.
- B. **WALKER WILL NOT BE LIABLE FOR ANY INCIDENTAL, CONSEQUENTIAL, OR SPECIAL DAMAGES AND/OR EXPENSES IN CONNECTION WITH THE PURCHASE OR USE OF THE MOWER.** Some states do not allow the exclusion or limitation of incidental or consequential damages, so the above limitation(s) or exclusion(s) may not apply to you.
- C. Only the warranty expressed in this limited warranty shall apply and no dealer, distributor, or individual is authorized to amend, modify, or extend this warranty in any way. Accordingly, additional statements such as dealer advertising or presentations, whether oral or written, do not constitute warranties by Walker, and should not be relied upon.
- D. This warranty gives you specific legal rights, and you may also have other rights which vary from state to state.

# WALKER MOWERS™

WALKER MFG. CO. • 5925 E. HARMONY ROAD, FORT COLLINS, CO 80528 • (970) 221-5614  
FORM NO. 110104      PRINTED IN USA      [www.walkermowers.com](http://www.walkermowers.com)      ©2004 WALKER MFG. CO