

# Walker Rider Lawnmowers

## ILLUSTRATED PARTS MANUAL

Model MC (18 HP)  
(Covers Serial Numbers 03-61061 and on)

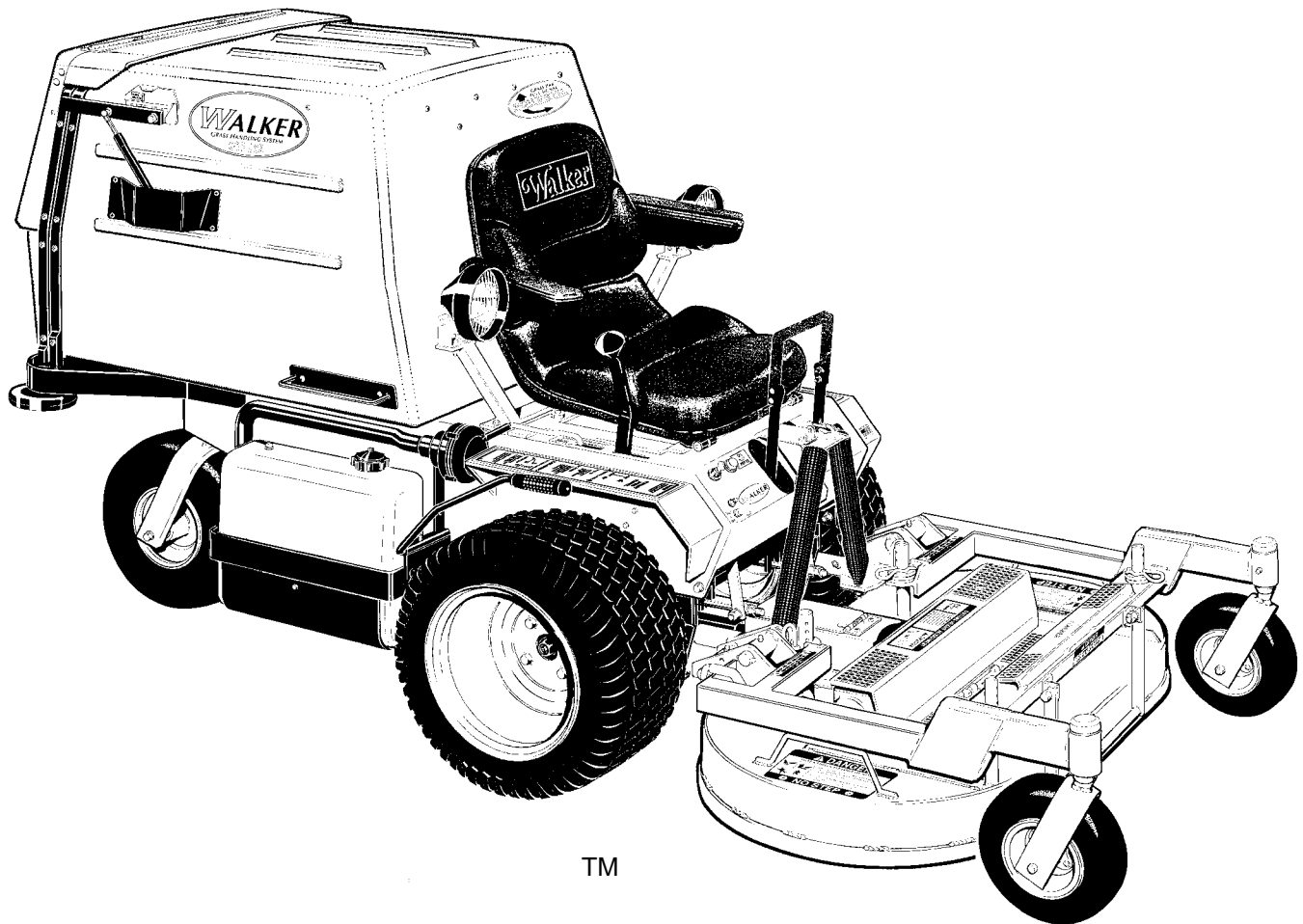

TM

CE

Effective Date:  
11-01-03

P/N 6000-9  
Price \$5.00

# KEY TO ABBREVIATIONS USED IN THIS MANUAL

<i>Abbreviation</i>	<i>What it Represents</i>
° (Dimension)	Degrees (Angle)
" (Dimension)	inches
(-)	Negative (Polarity)
(+)	Positive (Polarity)
AT	All-Terrain
CCW	Counter-clockwise
Conn.	Connector
CW	Clockwise
D	Diameter
DGHS	Deck, Grass Handling System (number refers to size in inches)
DML	Deck, Mulching (number refers to size in inches)
DSD	Deck, Side Discharge (number refers to size in inches)
DU	Garlock (Bearing)
ESNA (Fastener)	Nylon Insert Locknut
FSC	Forward Speed Control
GA	Gauge
gal.	gallon
GHS	Grass Handling System
GR (Fastener)	Grade
HP	Horse Power
HT	Heat-Treated
ID	Identification or Inside Diameter
L	Length
LH	Left Hand (orientated with operator on seat)
LP	Low Profile
mm (Dimension)	millimeters
MS (Fastener)	Machine Screw
NS (as part number)	Item is not sold by Walker Manufacturing
OD	Outside Diameter
oz.	ounce
PFH (Fastener)	Phillips Flat Head
P/N	Part Number
PPH (Fastener)	Phillips Pan Head
PTH (Fastener)	Phillips Truss Head
PTO	Power Take-Off
QKS	Quick Slide
qt.	quart
RH	Right Hand (orientated with operator on seat)
SAE (Fastener)	Society of Automotive Engineers
SBH (Fastener)	Socket Button Head (Bolt)
SD	Side Discharge
SFH (Fastener)	Slotted Flat Head
SHC (Fastener)	Socket Head Cap
SHL (Fastener)	Shoulder (Bolt)
SM (Fastener)	Sheet Metal (Screw)
S/N	Serial Number
Spg.	Spring
SQH (Fastener)	Square Head
SS (Fastener)	Stainless Steel
ST (Fastener)	Self-Tapping (Screw)
Term.	Terminal
V	Volts

**NOTE:** In some instances, combinations of abbreviations may be used (e.g. PPHMS - Phillips Pan Head Machine Screw).

Use only genuine **Walker**<sup>®</sup> replacement parts.

Effective Date 11-01-03

# ILLUSTRATED PARTS LIST

<i>Section of Mower Covered</i>	<i>Page</i>	<i>Section of Mower Covered</i>	<i>Page</i>
<hr/>		<hr/>	
<b>Decals</b>		<b>Electrical Components</b>	
Tractor Decals.....	2	Electrical Assemblies (Chassis Components) ....	32
<b>Body / Chassis Assemblies</b>		Electrical Assemblies (Body Components) .....	34
Body / Chassis Assembly (GHS Models).....	4	Electrical Assemblies (GHS 6.7 Bushel Components).....	36
Body Assembly (GHS 9.5 Bushel Models) .....	6	(GHS 9.5 Bushel Components).....	38
Body Assembly (SD Models) .....	8	Electrical Connectors .....	40
<b>Tractor Components</b>		<b>Options and Kits</b>	
Main Component Power Transmission (GHS Models) .....	10	Armrest Kit / Touch-Up Paint .....	42
(SD Models).....	12	Comfort Seat / Armrest Kit.....	44
Engine Group .....	14	Suspension Seat Kit .....	46
Hydrostatic Ground Drive Assemblies .....	16	Light Kit.....	48
Steering Control Assemblies.....	18	Blower Lockout Kit / Case-Hardened Blower.....	50
Throttle & Choke Control Assemblies .....	20	No Catch Deflector Kit (6.7 Bushel) .....	52
Parking Brake Assembly .....	22	No Catch Deflector Kit (9.5 Bushel) .....	54
GHS Group .....	24	All-Terrain Tire Kit & Tire Chain Sets.....	56
GHS Powerfil® Assembly .....	26	<b>Maintenance</b>	
GHS 6.7 Bushel Catcher & Exhaust Deflector Assemblies .....	28	Lubrication Points .....	58
GHS 9.5 Bushel Catcher & Exhaust Deflector Assemblies .....	30	Wiring Schematic.....	60
		<b>Warranty</b>	
		Limited Warranty.....	61

# TRACTOR DECALS

ITEM NO.	PART NO.	DESCRIPTION	LOCATION	NO. REQ'D. GHS	NO. REQ'D SD
<b>Walker Product and Operation Decals</b>					
1	7802	RH Fender	Body, RH near Seat	1	1
2	5856	Made in USA	Body, Spring Bracket	1	1
3	5803	Walker Manufacturing Logo	Body	1	1
4	5813-1	Powerfil®	6.7 / 9.5 Bushel Catcher, Front	1	0
5	5801	GHS	6.7 / 9.5 Bushel Catcher (one on each side)	2	0
6	5802-2	LH Fender	Body, LH near Seat	1	1
7	5800	Walker Mower (4 x 7-1/2)	Utility Bed (one on each side)	0	2
<b>Danger Decals Warning Decals Caution Decals</b>					
8	5805	Caution, Engine Exhaust	Body, LH Side	1	1
9	5861	Danger, Raised Body	Body - Underside, Center	1	1
10	5804	Danger, Rotating Blower Blades	Body near Body Chute	1	0
11	6810	Danger, Engine Exhaust	Engine	1	1
12	5868	Danger, Pinch Point	6.7 / 9.5 Bushel Catcher Mounting Frame Assembly (one on each side)	2	0
<b>Maintenance Decals</b>					
13	5815	Body Lift	Rear Bumper	1	1
14	5855	Important, Engine Cooling	Engine	1	1
15	5810-2	Reservoir	Hydrostatic Drives (one on each)	2	2
16	5810-1	Axle Oil Level	Gear Axle Drive Assemblies (one on each)	2	2
17	5819	Blower Maintenance	Blower Housing	1	0
18	6875	PTO Alignment Arrow	Universal Joint Tube Assembly	1	1
19	7827	Oil Level	Jackshaft Support	1	1
20	5869	Removable Screen	6.7 / 9.5 Bushel Catcher Removable Screen	1	0
21	5874	Push to Release	6.7 / 9.5 Bushel Catcher Safety Latch	1	0
22	6807	Oil Pressure	Body	1	1
23	7809	Parking Brake	Body, RH below seat	1	1
<b>Option Decals (applied only to units with corresponding Options installed)</b>					
24	5877	Lights, On-Off	Body	1	1
	8500-8	No Catch Deflector	6.7 / 9.5 Bushel No Catch Deflector, LH Side (Refer to 6.7 or 9.5 Bushel No Catch Deflector Kit Listing)	1	0
	8500-9	No Catch Deflector, Off-On	Body, RH above fender (Refer to 6.7 Bushel No Catch Deflector Kit Listing)	1	0

**NOTE:** All parts requiring decals are shipped with decals applied.

# TRACTOR DECALS

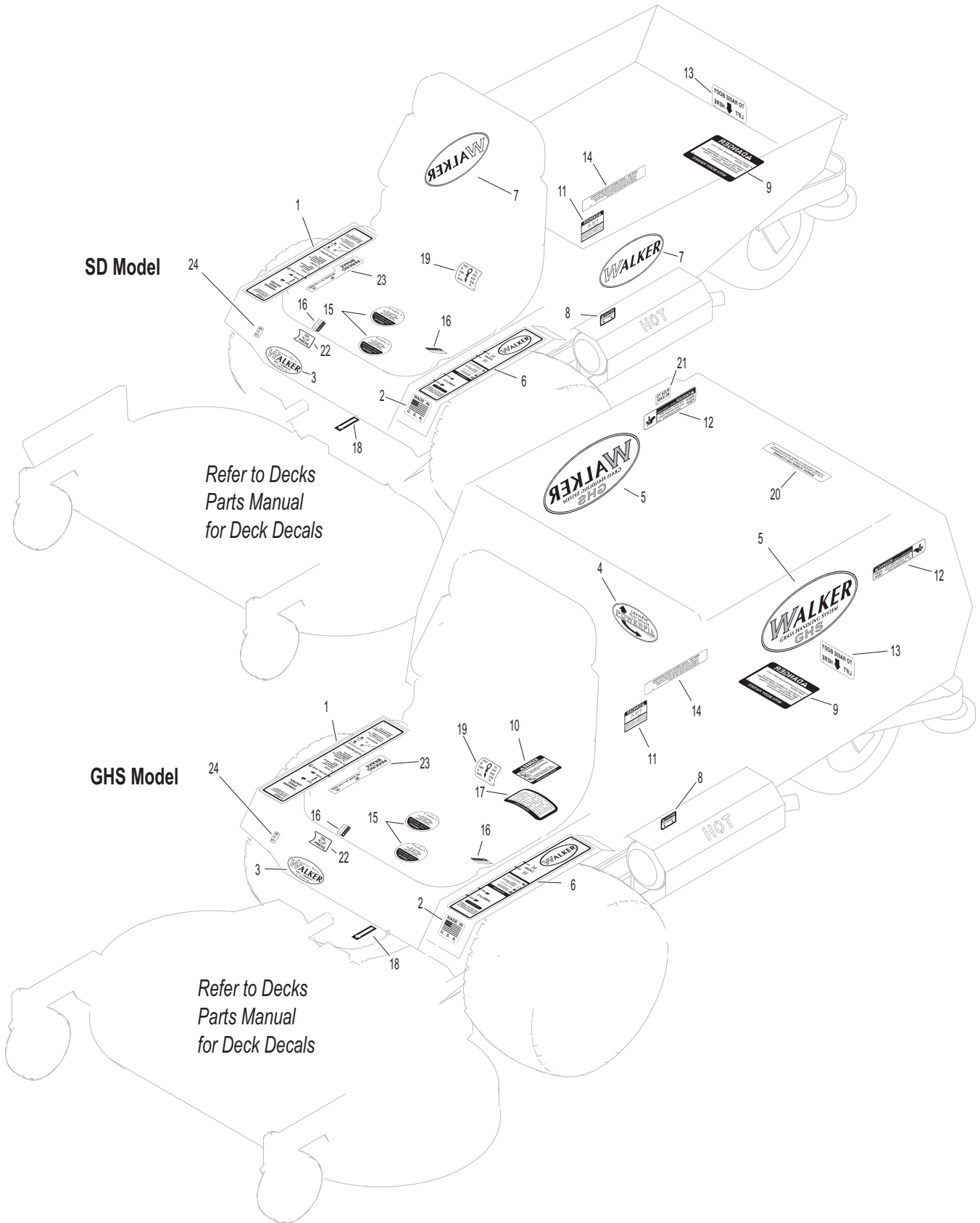

# BODY / CHASSIS ASSEMBLY (GHS MODELS)

ITEM NO.	PART NO.	DESCRIPTION	NO. REQ'D	ITEM NO.	PART NO.	DESCRIPTION	NO. REQ'D
<b>Seat Assembly</b>				37	6389	Splash Guard	1
1	5103	Seat	1	38	5075	LP Wheel & Tire Assembly (18 x 8.50-10)	2
2	7203	Seat Spring Plate	1		5075-2	LP Tire (18 x 8.50-10)	**
3	7223	Compression Spring (1/2 x 1)	2		5075-4	LP Wheel Only (10 x 7)	**
4	7845	Rubber Bumper (1.375 OD x .63)	2		5033-2	Wheel & Tire Assembly (18 x 6.50-8)	***
5	7846	Rubber Washer (3/8 ID x 1-1/4 OD x 1/8)	2		5030-2	Tire Only (18 x 6.50-8)	**
6	7204	Shoulder Bolt, Seat Mount	2		5031-2	Wheel Only (8 x 5.5)	**
7	7440-5	Shock Mount (1.25 x .75)	2		5030-4	Tire Tube (18 x 8.50-8)	**
<b>Rear Bumper Assembly (GHS 6.7 Bushel Models Only)*</b>				39	6307-1	Chassis Frame	1
8	5566	Tilt Stop Strap	1	<b>Fasteners</b>			
9	5516-8	Rear Bumper (6.7)	1	F002	10-24 Keps Nut		6
10	7516-5	Catcher Pivot Bushing	2	F004	1/4-20 Keps Nut		2
11	5162	Roller Wheel (5")	2	F009	5/16-18 Whiz Locknut		12
12	6100-17	Bumper Riser Bar	2	F012	3/8-16 Keps Nut		2
13	7517-2	Catcher Pivot Plate	2	F013	3/8-16 Whiz Locknut		2
<b>Body Assembly</b>				F014	3/8-16 ESNA Nut		4
14	6100-16	Welded Body	1	F016	1/2-13 Self-Locking Nut		1
15	5989-3	Dome Plug (5/16)	2	F020	5/16-18 ESNA Nut		1
16	5989-4	Dome Plug (3/8)	2	F026	10-24 x 1/2 PPHMS		5
17	7146	13mm Ball Stud	2	F027	10-24 x 5/8 PPHMS		1
18	5145	Gas Spring Assembly (Includes Items # 17 & 19)	1	F029	1/4-20 x 1/2 Hex Bolt		4
19	7147	Spring Clip	2	F040	3/8-16 x 1-1/2 Hex Bolt		2
20	5180	Edge Molding, Lever Opening	2	F042	3/8-16 x 2 1/4 Hex Bolt		2
21	5989-5	Dome Plug (7/16)	1	F048	1/2 SAE Washer		2
22	NS	Body ID Plate	1	F051	3/8 SAE Washer		2
<b>Tilt-Up Latch Assembly</b>				F059	3/8 Wave Spring Washer		2
23	5847	Plastic Tip	1	F085	3/16 Rivet Backup Washer		1
24	5744-20	Spring Arm, Tilt-Up Latch	1	F087	#10 x 7/8 Fender Washer		2
25	5744-10	Spring Pivot Bushing	1	F093	5/16-18 x 1 Hex Bolt		5
26	5744-15	Compression Spring (3/8 x 5/8)	1	F113	5/16-18 x 5/16 Set Screw		2
27	5744-13	Mount Angle / LH	1	F151	3/8-16 x 7/8 Hex Bolt		2
28	5744-12	Hook, Tilt-Up Latch	1	F157	1/2-20 x 1-1/4 Wheel Lug Bolt		8
29	5744-14	Mount Angle / RH	1	F206	#2 x 3/16 Drive Pin		2
<b>Chassis Assembly</b>				F227	3/8 x 1-1/4 x 1/8 Plastic Washer		2
30	5845	Rubber Bumper (1.50 OD x 1.25)	2	F241	.375 x .875 x .10 Washer		4
31	5267-1	Retainer Collar (1") (Includes Item # F113)	1	F292	1/2-13 x 8-1/2 Hex Bolt GR 2		1
32	5270-1	Pivot Bearing	2	F341	Coil Roll Pin (7/64 x 9/16)		1
33	5420-2	Tail Wheel Fork	1	F342	5/16 Conical Washer		2
34	5037-1	Bearing	2	* Rear Bumper Assembly for GHS 9.5 Bushel Models is not shown here. Refer to <b>BODY ASSEMBLY (GHS 9.5 BUSHEL MODELS)</b> , Page 6. Rear Bumper Assembly for SD Models is not shown here. Refer to <b>BODY ASSEMBLY (SD MODELS)</b> , Page 8.			
35	5035	Tail Wheel & Tire Assembly (13 x 6.50-6)	1	** Service Part Only			
	5035-1	Tail Wheel Tire (13 x 6.50-6)	**	*** May be ordered as a factory-installed option or for dealer installation. Narrow Drive Tires are used when installing a 36" Deck. Contact your Walker dealer.			
	5036	Tail Wheel & Hub (6 x 4.5)	**				
36	5038-1	Axle Spacer Tube (6-5/8)	1				

Use only genuine **Walker**<sup>®</sup> replacement parts.

Effective Date 11-01-03

# BODY / CHASSIS ASSEMBLY (GHS MODELS)

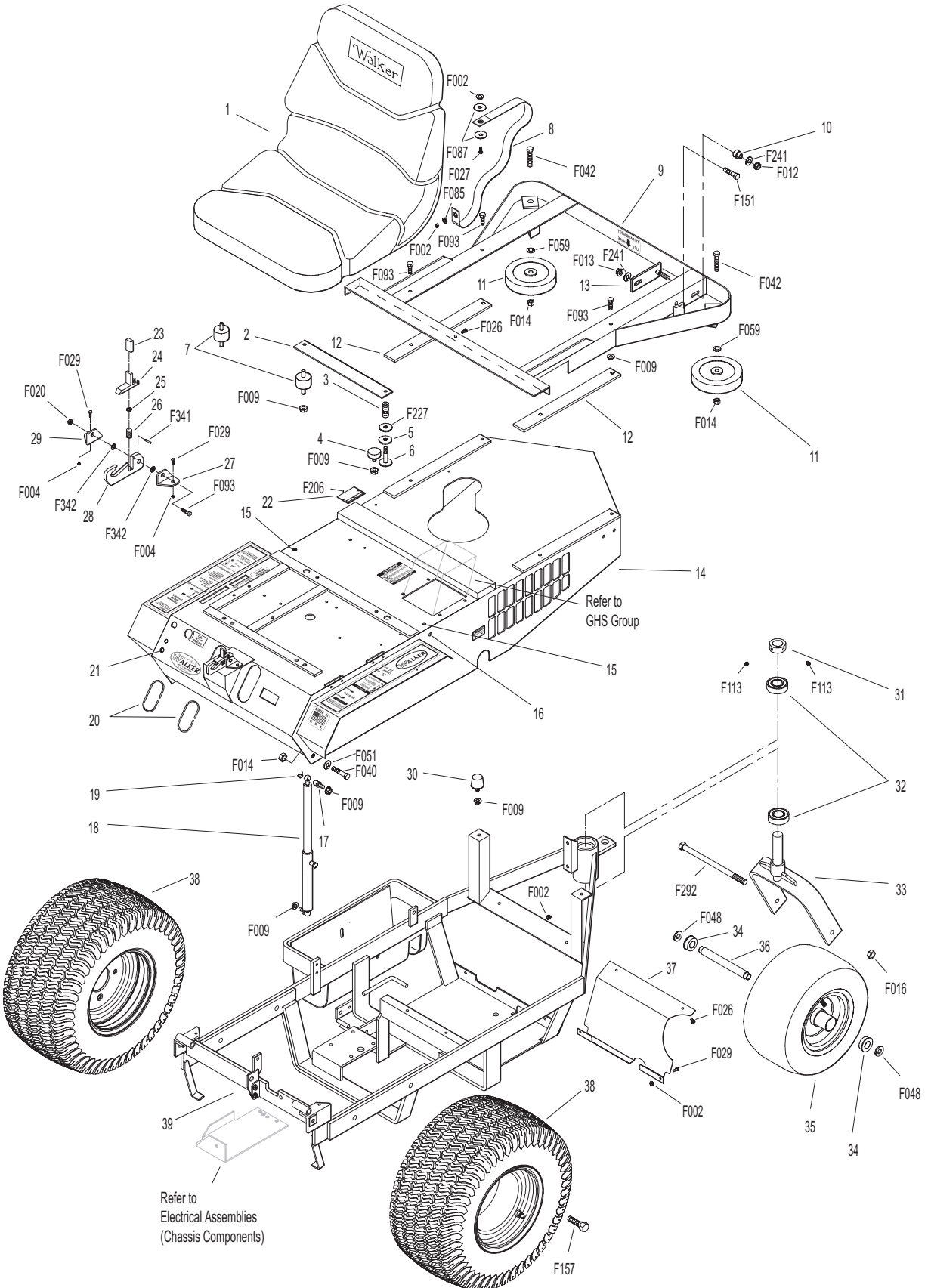

## BODY ASSEMBLY (GHS 9.5 BUSHEL MODELS)

ITEM NO.	PART NO.	DESCRIPTION	NO. REQ'D	ITEM NO.	PART NO.	DESCRIPTION	NO. REQ'D
<b>Body Assembly (GHS 9.5 Bushel Models Only)*</b>				<b>Fasteners</b>			
1	5566	Tilt Stop Strap	2	F002		10-24 Keps Nut	4
2	5516-9	Rear Bumper, GHS/9.5/C18	1	F009		5/16-18 Whiz Locknut	5
3	7516-5	Catcher Pivot Bushing	2	F012		3/8-16 Keps Nut	2
4	5162	Roller Wheel (5")	2	F013		3/8-16 Whiz Locknut	2
5	7517-2	Catcher Pivot Plate	2	F014		3/8-16 ESNA Nut	2
6	6100-17	Bumper Riser Bar	2	F026		10-24 x 1/2 PPHMS	2
7	5845	Rubber Bumper (1.50 OD x 1.25)	1	F027		10-24 x 5/8 PPHMS	2
8	5516-10	Bumper Mount	1	F042		3/8-16 x 2-1/4 Hex Bolt	2
				F059		3/8 Wave Spring Washer	2
				F085		3/16 Rivet Backup Washer	2
				F087		#10 x 7/8 Fender Washer	4
				F093		5/16-18 x 1 Hex Bolt	4
				F151		3/8-16 x 7/8 Hex Bolt	2
				F213		3/4-10 Jam Nut	2
				F241		.375 x .875 x .10 Washer	4

\* Rear Bumper Assembly for GHS 6.7 Bushel Models is not shown here. Refer to **BODY / CHASSIS ASSEMBLY (GHS MODELS)**, Page 4. Rear Bumper Assembly for SD Models is not shown here. Refer to **BODY ASSEMBLY (SD MODELS)**, Page 8.

**NOTE:** Refer to **BODY / CHASSIS ASSEMBLY (GHS MODELS)**, Page 4 for all common parts used on both GHS and SD models.



# BODY ASSEMBLY (GHS 9.5 BUSHEL MODELS)

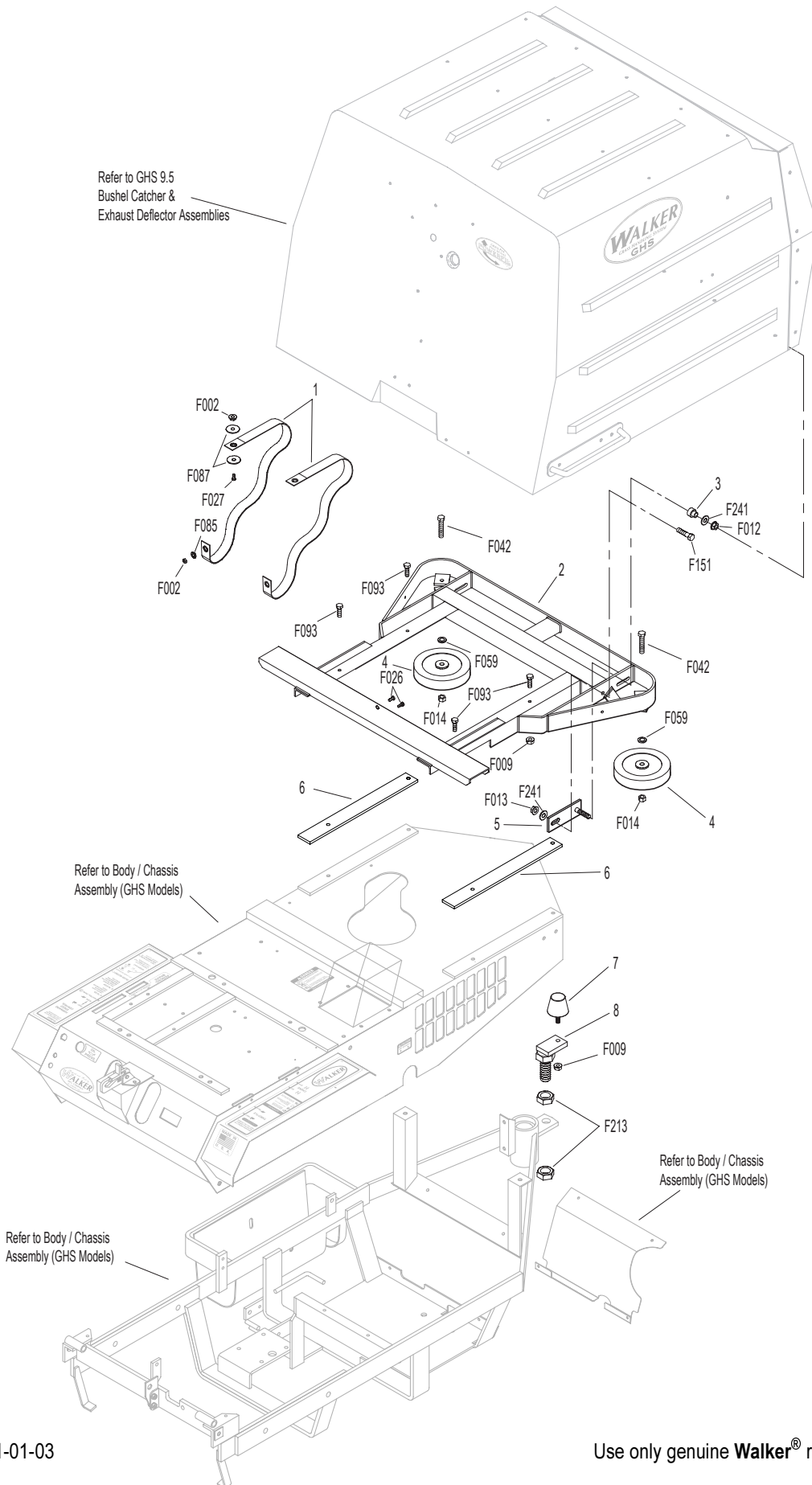

Effective Date 11-01-03

Use only genuine **Walker**® replacement parts.

# BODY ASSEMBLY (SD MODELS)

ITEM NO.	PART NO.	DESCRIPTION	NO. REQ'D	ITEM NO.	PART NO.	DESCRIPTION	NO. REQ'D
<b>Utility Bed Assembly</b>				<b>Fasteners</b>			
1	8650-10	Bed Liner (21.5 x 27.5)	1	F002		10-24 Keps Nut	4
2	5656	Utility Bed (Includes Items # 1 & 3)	1	F005		1/4-20 ESNA Nut	2
3	5845	Rubber Bumper (1.50 OD x 1.25)	2	F009		5/16-18 Whiz Locknut	10
4	5652-3	Utility Bed Mount / LH	1	F014		3/8-16 ESNA Nut	2
5	5651-2	Utility Bed Mount / RH	1	F020		5/16-18 ESNA Nut	2
<b>Rear Bumper Assembly (SD Models Only)*</b>				F033		1/4-20 x 1 PTH Bolt	2
6	7153-3	Cover Plate	1	F034		5/16-18 x 3/4 Hex Bolt	8
7	5112	Rear Bumper	1	F050		1/4 SAE Washer	2
8	5161	Bumper Pad	2	F059		3/8 Wave Spring Washer	2
9	5162	Roller Wheel (5")	2	F084		5/16 Wave Spring Washer	2
				F091		5/16-18 x 5/8 Hex Bolt	2
				F128		10-24 x 3/8 PTHMS	4

\* Rear Bumper Assembly for GHS Models is not shown here. Refer to **BODY / CHASSIS ASSEMBLY (GHS MODELS)**, Page 4, or **BODY ASSEMBLY (GHS 9.5 BUSHEL MODELS)**, Page 6.

**NOTE:** Refer to **BODY / CHASSIS ASSEMBLY (GHS MODELS)**, Page 4 for all common parts used on both GHS and SD models.

# BODY ASSEMBLY (SD MODELS)

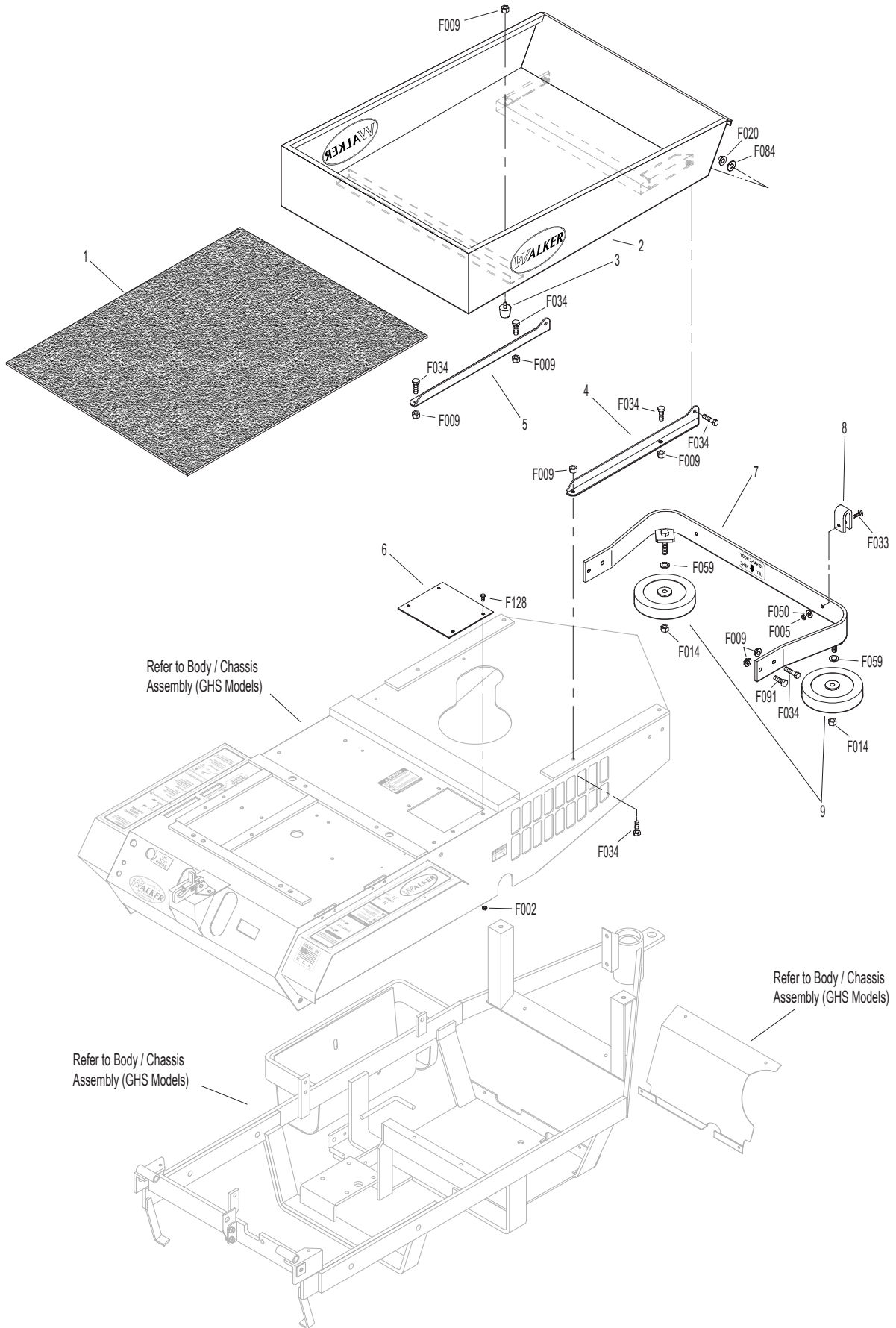

# MAIN COMPONENT POWER TRANSMISSION (GHS MODELS)

ITEM NO.	PART NO.	DESCRIPTION	NO. REQ'D	ITEM NO.	PART NO.	DESCRIPTION	NO. REQ'D
<b>Clutch Lever Assembly</b>				43	5268	Bearing with Collar (3/4)	2
1	6358-1	Clutch Lever (Includes Items # 2 & 3)	1	44	7833	Cable Clamp (7/8 x 1/4)	1
2	5830	Grease Fitting	7	45	7241-2	Transmission Drive Pulley, Micro-V (Includes Item # F171)	1
3	7860	Handle Grip	1	46	8539	Starter Relay Mount	1
4	7303-10	Clutch Actuator Bolt (3/8)	1	47	8349	Transmission Belt Tightener Arm	1
5	7380-5	Knuckle Joint, 3/8 ID	1	48	8393	Jackshaft Support	1
6	7226-10	Compression Spring (3/4 x 2-1/2)	1	49	8273	Jackshaft (3/4 x 7-1/2)	1
7	8130-5	Pushrod, Clutch Actuator	1	50	7240-1	Jackshaft Drive Pulley (3-1/2 / 3V) (Includes Item # F171)	1
8	8130-10	Clutch Actuator Rod Assembly (Includes Items # 2, 4-7, F054, F336 & F353)	1	<b>Fasteners</b>			
9	7201-3	DU Bearing	6		F002	10-24 Keps Nut	1
10	7201-5	Inner Race (2-1/4)	1		F003	1/4-28 Hex Nut	2
11	8368	PTO Belt Tightener	1		F004	1/4-20 Keps Nut	3
12	5841	Retainer Washer	4		F005	1/4-20 ESNA Nut	1
13	8243-1	Clutch Idler Pulley	1		F009	5/16-18 Whiz Locknut	3
	8243	Clutch Idler Pulley Assembly (Includes Items # 14, 15 & F070)	*		F012	3/8-16 Keps Nut	8
14	5265	Bearing (3/4)	1		F021	11/16 x 1 x .015 Shim Washer, Steel	2
15	8243-3	Hub, Idler Pulley	1		F025	10-24 x 3/8 PPHMS	1
16	8375	PTO Belt Tightener Stop	1		F029	1/4-20 x 1/2 Hex Bolt	1
17	7377	Plastic Washer (7/16 x 1 x .025)	2		F034	5/16-18 x 3/4 Hex Bolt	2
18	7378	Pivot Bearing (7/16 x 9/16)	1		F040	3/8-16 x 1-1/2 Hex Bolt	1
19	5281-5	Clevis Pin (1/4 x 0.80)	2		F041	3/8-16 x 1-3/4 Hex Bolt	2
20	5280	Clevis (1/4)	2		F042	3/8-16 x 2-1/4 Hex Bolt	3
21	8305	Brake Actuator Rod	1		F043	3/8-16 x 3 Hex Bolt	1
22	8370	Bearing, Brake Actuator	1		F047	3/8-16 x 4-1/2 Hex Bolt	1
23	8250	Brake Spring (1/2 x 2-1/2)	1		F054	AN960616 Washer	4
24	8369	Brake Actuator (Includes Items # 2 & 22)	1		F061	1/4 Internal Star Lock Washer	1
<b>PTO Drive Shaft Assembly</b>					F067	3/16 x 3/16 x 1 Key	2
25	7050-1	Dipstick, Gearbox	1		F069	3/32 x 1/2 Cotter Pin	2
26	8371-1	Mount Bracket, Brake Band	1		F070	1-3/4 Internal Snap Ring	1
27	8377	Brake Band Guide	1		F116	1/4-20 x 1-1/4 Hex Bolt	1
28	8050-11	PTO Gearbox / Flange Pulley	1		F121	5/16-18 x 3/8 x 1 SHL Bolt	1
29	5245	Idler Pulley (3")	2		F131	5/16-18 x 1/2 Hex Bolt	2
30	7248	Ground Drive Belt, Micro-V	1		F132	1/4-20 x 2-3/4 Hex Bolt	1
31	7275-16	Universal Joint Tube Assembly (Spline)	1		F168	5/16 Split Lock Washer	12
32	7523-2	Clevis Pin (1/4 x 5/8)	1		F171	5/16-18 x 3/8 Set Screw	4
33	8304	Brake Band (14-1/2)	1		F178	1/4 x 1 Fender Washer	1
34	6251-1	Drive Belt (3VX385)	1		F182	5/8 x 1/4 x 1/8 Washer	2
35	7236-1	PTO Drive Pulley (4-V213V) (Includes Items # F168 & F226)	1		F186	5/64 x 1/2 Cotter Pin	1
36	8237-2	Engine Pulley (4/3-8/3V) (Includes Item # F168 & F226)	1		F226	5/16-18 x 7/8 Hex Bolt	12
37	8230	Engine PTO Belt	1		F241	.375 x .875 x .10 Washer	1
<b>Jackshaft Assembly</b>					F325	1/4-20 x 3 Hex Bolt	1
38	7245-1	Idler Pulley (3/8 Groove)	1		F336	3/8-16 Jam Nut	1
39	6325-2	Spacer Bushing (5/16)	2		F353	3/8-16 ESNA LP Nut	1
40	8349-2	Idler Arm	1				
41	7201-4	Inner Race (1-1/2)	2				
42	5221	Extension Spring (3/4 x 4)	2				
				*	Service Part Only		

Use only genuine **Walker**<sup>®</sup> replacement parts.

Effective Date 11-01-03

# MAIN COMPONENT POWER TRANSMISSION (GHS MODELS)

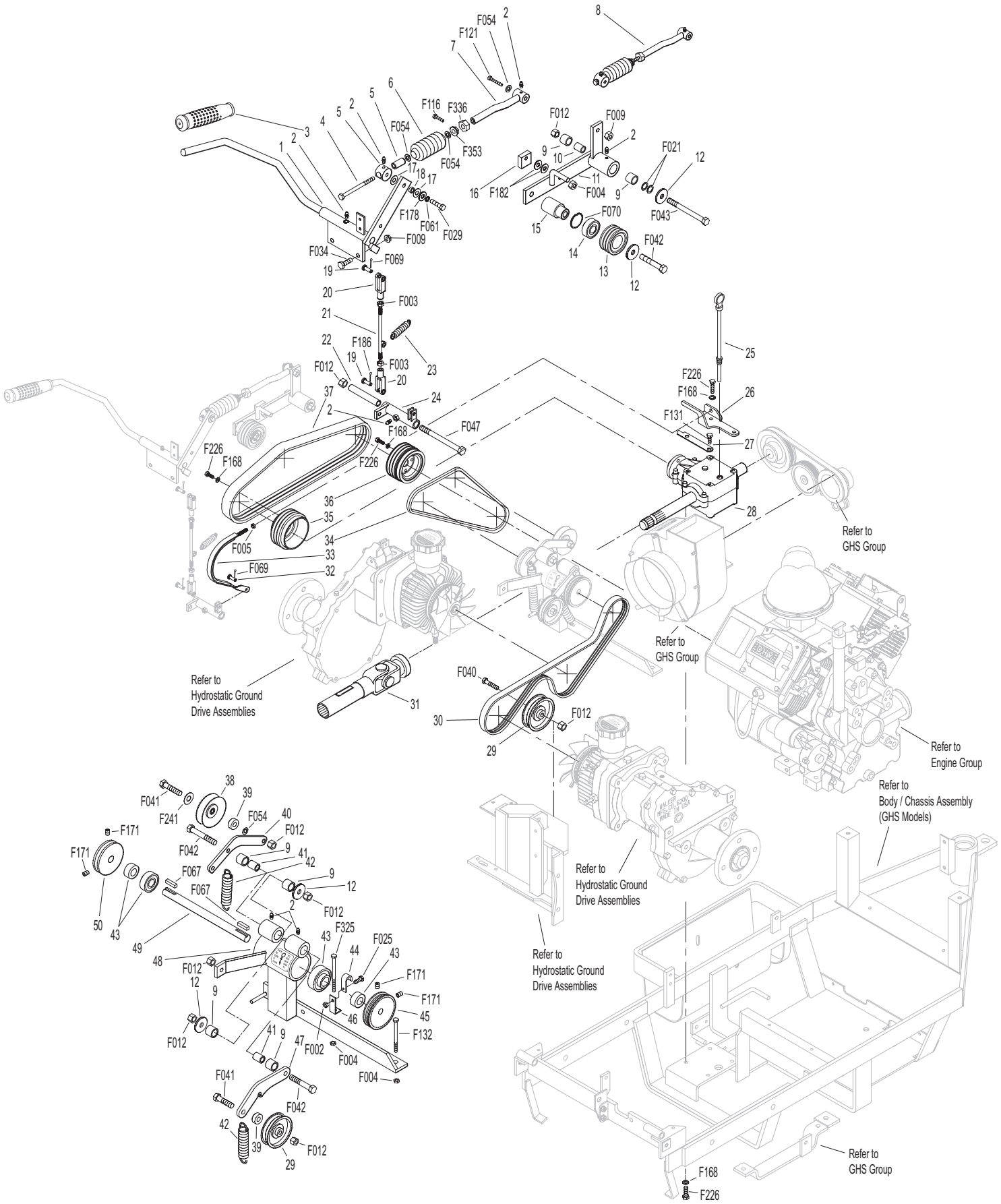

Effective Date 11-01-03

Use only genuine Walker® replacement parts.

# MAIN COMPONENT POWER TRANSMISSION (SD MODELS)

ITEM NO.	PART NO.	DESCRIPTION	NO. REQ'D	ITEM NO.	PART NO.	DESCRIPTION	NO. REQ'D
<b>Clutch Lever Assembly</b>				43	7241-2	Transmission Drive Pulley, Micro-V (Includes Item # F171)	1
1	6358-1	Clutch Lever (Includes Items # 2 & 3)	1	44	7833	Cable Clamp (7/8 x 1/4)	1
2	5830	Grease Fitting	7	45	8539	Starter Relay Mount	1
3	7860	Handle Grip	1	46	5268	Bearing with Collar (3/4)	2
4	7303-10	Clutch Actuator Bolt (3/8)	1	47	8349	Transmission Belt Tightener Arm	1
5	7380-5	Knuckle Joint, 3/8 ID	1	48	8393	Jackshaft Support	1
6	7226-10	Compression Spring (3/4 x 2-1/2)	1	49	8273	Jackshaft (3/4 x 7-1/2)	1
7	8130-5	Pushrod, Clutch Actuator	1	50	7240-1	Jackshaft Drive Pulley (3-1/2 / 3V) (Includes Item # F171)	1
8	8130-10	Clutch Actuator Rod Assembly (Includes Items # 2, 4-7, F054, F336 & F353)	1	<b>Fasteners</b>			
9	7201-3	DU Bearing	6	F002	10-24 Keps Nut		1
10	7201-5	Inner Race (2-1/4)	1	F003	1/4-28 Hex Nut		2
11	8368	PTO Belt Tightener	1	F004	1/4-20 Keps Nut		3
12	5841	Retainer Washer	4	F005	1/4-20 ESNA Nut		1
13	8243-1	Clutch Idler Pulley	1	F009	5/16-18 Whiz Locknut		3
	8243	Clutch Idler Pulley Assembly (Includes Items # 14, 15 & F070)	*	F012	3/8-16 Keps Nut		8
14	5265	Bearing (3/4)	1	F021	11/16 x 1 x .015 Shim Washer, Steel		2
15	8243-3	Hub, Idler Pulley	1	F025	10-24 x 3/8 PPHMS		1
16	8375	PTO Belt Tightener Stop	1	F029	1/4-20 x 1/2 Hex Bolt		1
17	7377	Plastic Washer (3/16 x 1 x .025)	2	F034	5/16-18 x 3/4 Hex Bolt		2
18	7378	Pivot Bearing (7/16 x 9/16)	1	F040	3/8-16 x 1-1/2 Hex Bolt		1
19	5281-5	Clevis Pin (1/4 x 0.80)	2	F041	3/8-16 x 1-3/4 Hex Bolt		2
20	5280	Clevis (1/4)	2	F042	3/8-16 x 2-1/4 Hex Bolt		3
21	8305	Brake Actuator Rod	1	F043	3/8-16 x 3 Hex Bolt		1
22	8370	Bearing, Brake Actuator	1	F047	3/8-16 x 4-1/2 Hex Bolt		1
23	8250	Brake Spring (1/2 x 2-1/2)	1	F054	AN960616 Washer		4
24	8369	Brake Actuator (Includes Items # 2 & 22)	1	F061	1/4 Internal Star Lock Washer		1
<b>PTO Drive Shaft Assembly</b>				F067	3/16 x 3/16 x 1 Key		2
25	7050-1	Dipstick, Gearbox	1	F069	3/32 x 1/2 Cotter Pin		2
26	8371-1	Mount Bracket, Brake Band	1	F070	1-3/4 Internal Snap Ring		1
27	8377	Brake Band Guide	1	F090	1/4-20 x 2-1/2 Hex Bolt		1
28	8050-11	PTO Gearbox / Flange Pulley	1	F116	1/4-20 x 1-1/4 Hex Bolt		1
29	5245	Idler Pulley (3")	2	F121	5/16-18 x 3/8 x 1 SHL Bolt		1
30	7248	Ground Drive Belt, Micro-V	1	F131	5/16-18 x 1/2 Hex Bolt		2
31	7275-16	Universal Joint Tube Assembly (Spline)	1	F132	1/4-20 x 2-3/4 Hex Bolt		1
32	7523-2	Clevis Pin (1/4 x 5/8)	1	F168	5/16 Split Lock Washer		12
33	8304	Brake Band (14-1/2)	1	F171	5/16-18 x 3/8 Set Screw		4
34	6251-1	Drive Belt (3VX385)	1	F178	1/4 x 1 Fender Washer		1
35	7236-1	PTO Drive Pulley (4-V213V) (Includes Items # F168 & F226)	1	F182	5/8 x 1/4 x 1/8 Washer		2
36	8237-2	Engine Pulley (4/3-8/3V) (Includes Item # F168 & F226)	1	F186	5/64 x 1/2 Cotter Pin		1
37	8230	Engine PTO Belt	1	F226	5/16-18 x 7/8 Hex Bolt		12
<b>Jackshaft Assembly</b>				F241	.375 x .875 x .10 Washer		1
38	7245-1	Idler Pulley (3/8 Groove)	1	F336	3/8-16 Jam Nut		1
39	6325-2	Spacer Bushing (5/16)	2	F353	3/8-16 ESNA LP Nut		1
40	8349-2	Idler Arm	1	* Service Part Only			
41	7201-4	Inner Race (1-1/2)	2				
42	5221	Extension Spring (3/4 x 4)	2				

Use only genuine Walker® replacement parts.

Effective Date 11-01-03

# MAIN COMPONENT POWER TRANSMISSION (SD MODELS)

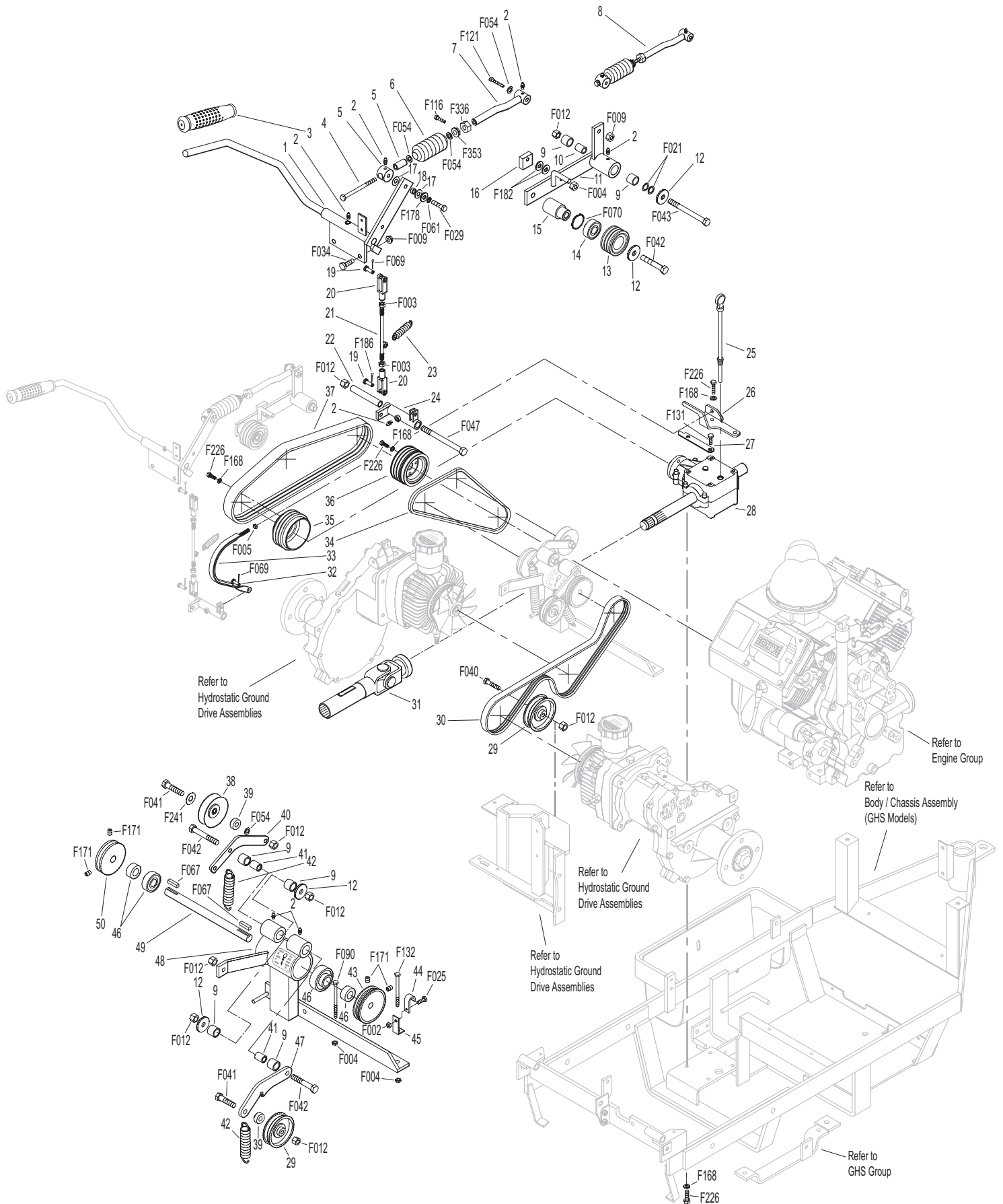

Effective Date 11-01-03

Use only genuine Walker® replacement parts.

# ENGINE GROUP

ITEM NO.	PART NO.	DESCRIPTION	NO. REQ'D	ITEM NO.	PART NO.	DESCRIPTION	NO. REQ'D
<b>Precleaner Assembly</b>				<b>Engine &amp; Exhaust Assemblies</b>			
1	7026-2	Remote Precleaner (Includes Item # 2)	1	24	5082	Fuel Tank Cap (Includes Item # 25)	*
2	7840	Hose Clamp (1-5/16 to 2-1/4)	3	25	5082-2	Fuel Cap Seal	*
3	6028-1	Precleaner Tube	1	26	5083-2	Tank Tube Elbow	1
4	7027	Elbow, Precleaner	1	27	5879-3	Hose Clamp (1/2)	5
5	6029	Hose Clamp (2-1/2)	2	28	5083-1	Bushing, Rubber	*
6	6087-1	Air Intake Hose, MC 18HP	1	29	5086	Fuel Line (In Tank P/U)	1
7	5088-11	Air Cleaner Cap	1	30	5975-3	Cable Tie (50# x 7")	2
8	5088-1	Air Cleaner Band	1	31	8015-3	Fuel Line, Tank (1/4 x 24-1/2)	1
9	5090-1	Air Cleaner Cartridge	1	32	NS	Fuel Line, Engine (Kohler)	*
10	6090-10	Air Cleaner Assembly (Includes Items # 7, 9, 11-14 & 15)	*	33	5020	Fuel Filter	1
11	5090-3	Safety Filter	1	34	8023	Fuel Tank Support	1
12	5090-2	Vacuator Valve	1	35	5020-1	Fuel Filter, In Tank	1
13	5088-5	Air Cleaner Draw Latch	1	36	6046-2	Fuel Tank, 3.0 gal., Gas (Includes Items # 24, 25 & 28)	1
14	5091-9	Elbow, Brass 90° (1/8 x 1/8 NPT)	1				
15	5091-11	Air Flow Indicator & Nipple	1				
<b>Fuel Tank Assembly</b>				<b>Fasteners</b>			
16	NS	18 HP Engine (Kohler CH18S, Spec. # 62623)	1	F002		10-24 Keps Nut	2
17	NS	Oil Filter (Kohler 2805001)	1	F004		1/4-20 Keps Nut	5
18	NS	Gasket (Kohler 2404102)	2	F009		5/16-18 Whiz Locknut	2
19	NS	Nut (Kohler M-0841080)	4	F025		10-24 x 3/8 PPHMS	2
20	6013-3	Muffler	1	F029		1/4-20 x 1/2 Hex Bolt	2
21	6013-4	Muffler Heat Shield	1	F031		1/4-20 x 5/8 Hex Bolt	3
22	6013-6	Muffler Heat Deflector	1	F050		1/4 SAE Washer	2
23	6013-5	Muffler Brace / 18HP	1	F051		3/8 SAE Washer	2
				F061		1/4 Internal Star Lock Washer	2
				F063		3/8 Internal Star Lock Washer	2
				F091		5/16-18 x 5/8 Hex Bolt	2
				F120		AN960416 Washer	2
				F151		3/8-16 x 7/8 Hex Bolt	2
				F184		1/4-20 x 1/2 Hex Bolt SS	7
				F185		1/4 Internal Star Lock SS	5
				F218		7/16 Split Lock Washer	4
				F219		7/16-14 x 1-1/4 Hex Bolt	4

\* Service Part Only

**NOTE:** Refer to Kohler Engine Decal (NS) for Engine Identification Numbers.



# ENGINE GROUP

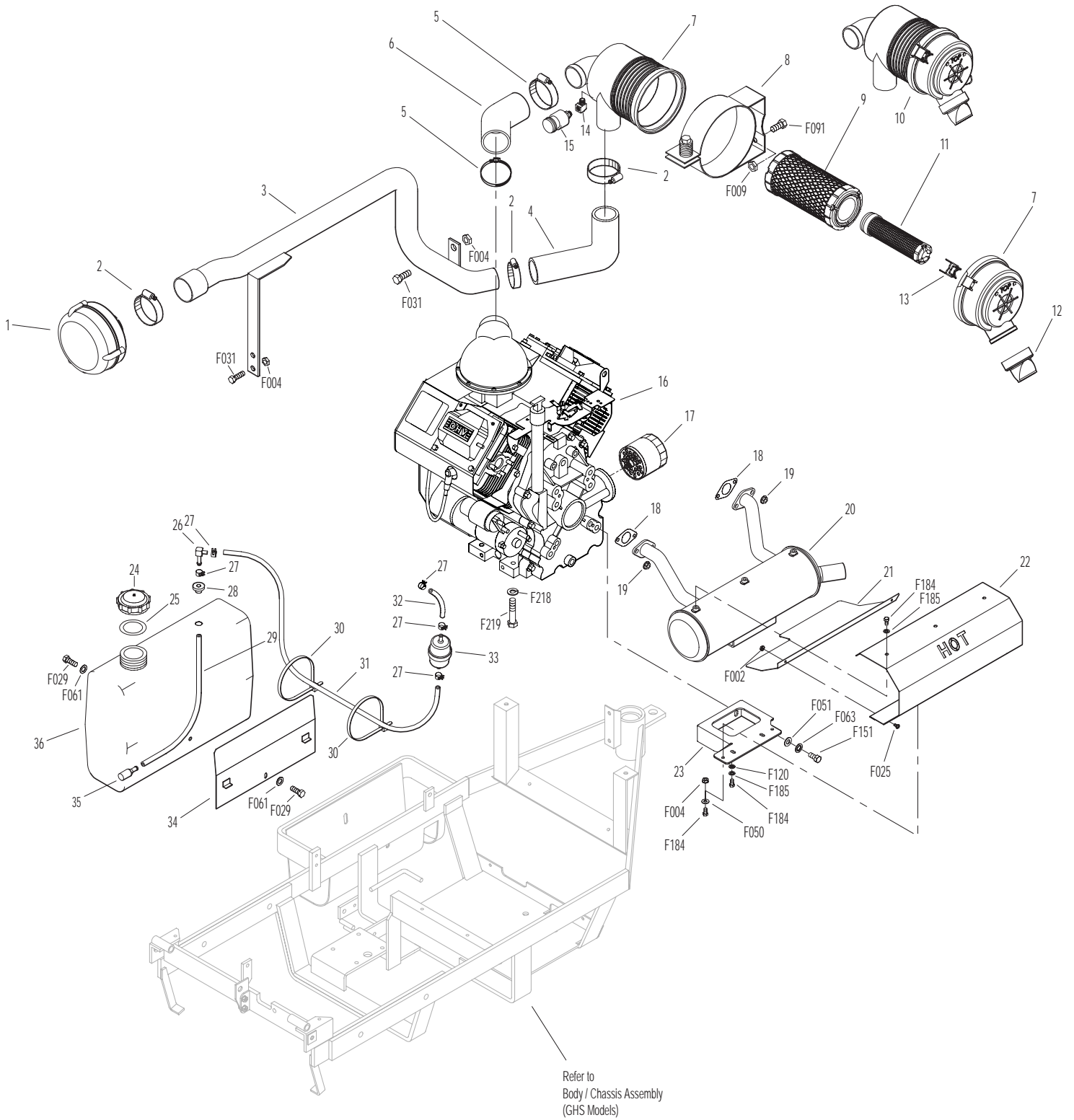

# HYDROSTATIC GROUND DRIVE ASSEMBLIES

ITEM NO.	PART NO.	DESCRIPTION	NO. REQ'D	ITEM NO.	PART NO.	DESCRIPTION	NO. REQ'D
<b>Transmission Lockout Assembly</b>				<b>Transmission Repair Parts</b>			
1	5028-3	Transmission Lockout Assembly with Mount* (Includes Items # 2-5, F023 & F027)		25	5025-5	Input Shaft	*
2	5847	Plastic Tip	2	26	5025-8	Bearing, Input Shaft	*
3	5057	Lockout Cam (Includes Item # F081)	2	27	5025-7	Snap Ring	*
4	5028-5	Lockout Lever	2	28	5025-2	Seal, Input Shaft	*
5	5027-5	Lockout Mount	2	29	5022	Reservoir to Casting Gasket	*
<b>Ground Drive Assemblies</b>				30	5024	Reservoir Cap and Gasket	*
6	6209-1	Bridge Assembly	1	31	5023	Transmission Reservoir Kit	*
7	6243-2	Hydro Fan, CCW	1	32	5023-1	Rubber Bladder	*
8	5026	Hydrostatic Drive, CW (700-041)	1	33	5025-6	O-Ring & Plug Assembly	*
9	6206-1	Air Vent Valve	*	34	5025-3	Seal, Control Shaft	*
10	6200-9	Gear Axle Drive Assembly (Includes Item # 9)	2	<b>Fasteners</b>			
11	5126	Cable Retainer (Uses existing bolt Gear Axle Drive Assembly)	1	F012	3/8-16 Keps Nut		1
12	6233-1	Pinion Gear	2	F023	10-24 ESNA Nut		2
13	6234	Spacer, Pinion Gear	2	F027	10-24 x 5/8 PPHMS		2
14	6201	O-Ring Seal	2	F036	1/4-20 x 1/2 SBH Screw		2
15	7244	Hydro Pulley (3-7/8 MV)	2	F038	3/8-16 x 1 Hex Bolt		4
16	6243-1	Hydro Fan, CW	1	F040	3/8-16 x 1-1/2 Hex Bolt		4
17	5025	Hydrostatic Drive, CCW (700-042)	1	F043	3/8-16 x 3 Hex Bolt		7
<b>Deck Support Arm Assemblies</b>				F053	7/16 Internal Star Lock Washer		4
18	6430-10	Outboard Mount, LH	1	F063	3/8 Internal Star Lock Washer		16
19	6430-2	Deck Support Arm, LH (Includes Item # 23)	1	F064	1/8 x 1/2 Woodruff Key (#3)		4
20	5775-2	Hitch Pin (# 6)	2	F081	A/A45D Aluminum Pop Rivet		2
21	6430-1	Deck Support Arm, RH (Includes Item # 23)	1	F160	External Snap Ring (.669 Shaft)		2
22	6430-9	Outboard Mount, RH	1	F178	1/4 x 1 Fender Washer		2
23	5830	Grease Fitting	2	F194	7/16 x 1-1/4 x 1/8 Washer		2
24	6840-1	Support Arm Bushing (2-1/16)	2	F200	7/16-20 x 3 Grade 8 Bolt		2
				F244	7/16-20 x 3/4 Hex Bolt		2
				F262	3/8-16 x 4 Hex Bolt (Spec) All Thread		1
				F359	5/16-18 x 5/16 Set Screw (Unbrako Knurl Point)		4
				* Service Part Only			

# HYDROSTATIC GROUND DRIVE ASSEMBLIES

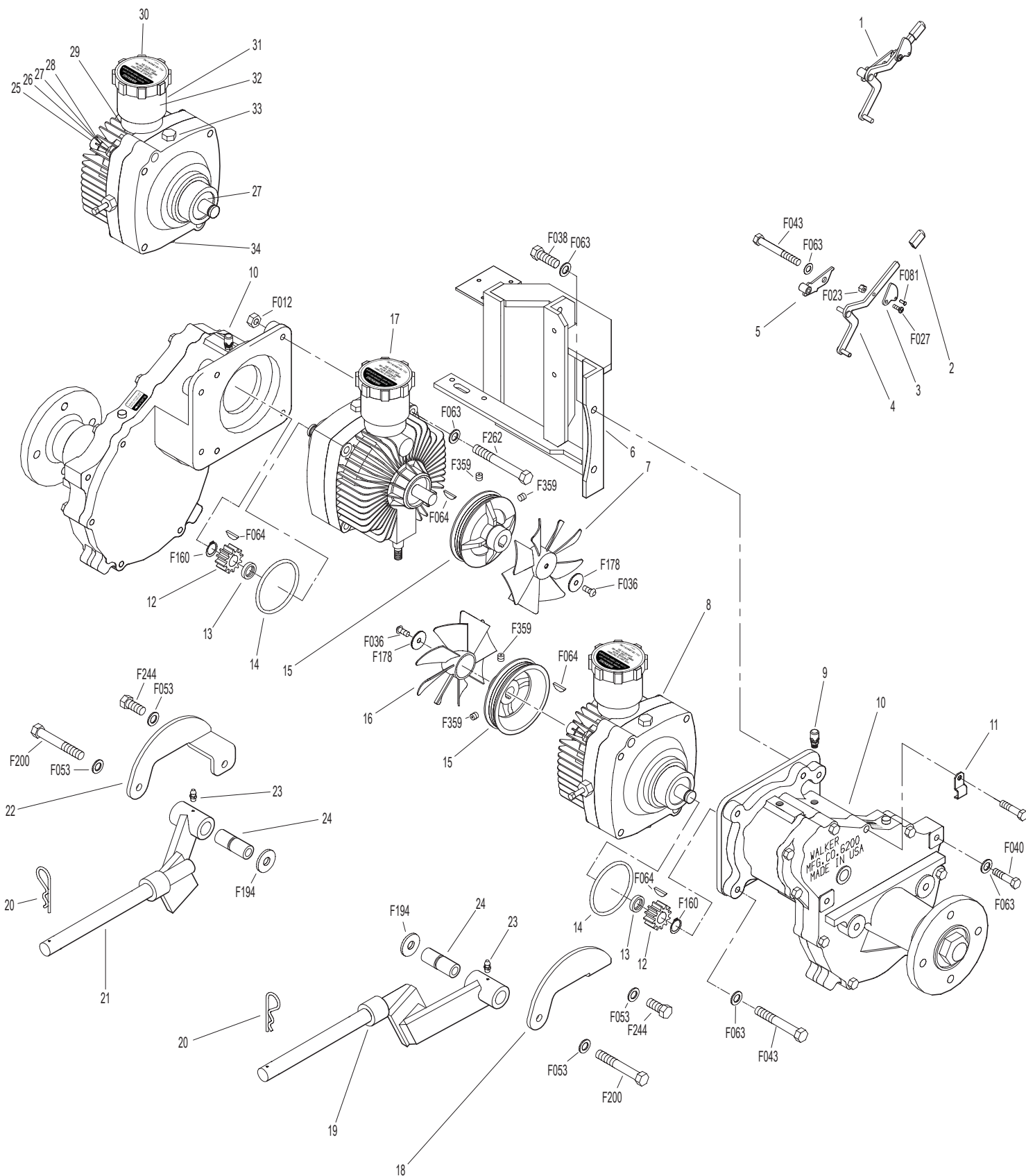

# STEERING CONTROL ASSEMBLIES

ITEM NO.	PART NO.	DESCRIPTION	NO. REQ'D	ITEM NO.	PART NO.	DESCRIPTION	NO. REQ'D
<b>Transmission Spring Assemblies</b>				33	5281-5	Clevis Pin (1/4 x 0.80)	1
1	6199	Transmission Spring Assembly (RH) (Includes Items # 2-8, F003, F287 & F352)	*	34	5470-1	Speed Control Stop	1
2	5552	Ball Joint (1/4-28)	2	35	5450-3	Steering Lever Assembly, RH (Includes Items # 16, 21, 36, F188, F198 & F345)	1
3	5192-1	Spring Plunger (5/32)	2		5450-5	Adjustable Steering Lever Arm, RH	*
4	5194	Plunger Sleeve	2	36	5453-10	Adjustable Steering Lever Handle (Includes Items # 21 & F345)	2
5	6191	Spring Slide (4-3/4)	1	37	5862	FSC Knob	1
6	5195	Compression Spring (1 x 5-1/8)	2	38	7170	FSC Lever Assembly (Includes Item # 16)	1
7	5193	Washer (3/4 x 1 x .085)	2	39	5213-1	Control Rod, RH (15")	1
8	6196	Spring Slide Cap	1	<b>Fasteners</b>			
9	5197	J-Bolt	1	F003	1/4-28 Hex Nut	3	
10	5191	Spring Slide (3-5/8)	1	F004	1/4-20 Keps Nut	8	
11	5199	Transmission Spring Assembly (LH) (Includes Items # 2-4, 6, 7, 9, 10, F003, F146, F287 & F352)	*	F007	5/16-18 Jam Nut	1	
<b>Steering Lever &amp; FSC Assemblies</b>				F008	5/16-24 Keps Nut	2	
12	5214-2	Ball Joint (5/16-24), Nylon Lined	2	F009	5/16-18 Whiz Locknut	1	
13	5173	FSC Actuator Rod	1	F010	5/16-24 ESNA Nut	2	
14	5172	Bearing, Nylon (.255 ID x .379 OD x .250)	1	F012	3/8-16 Keps Nut	2	
15	5142-2	FSC Actuator Cam	1	F024	5/16-24 Jam Nut	2	
16	5830	Grease Fitting	6	F029	1/4-20 x 1/2 Hex Bolt	2	
17	6212	Transmission Control Arm, RH	1	F032	1/4-20 x 3/4 Hex Bolt	4	
18	5141	FSC Friction Washer	2	F034	5/16-18 x 3/4 Hex Bolt	1	
19	5140-15	FSC Friction Body (Includes Item # 16)	1	F050	1/4 SAE Washer	3	
20	5142-7	FSC Key	1	F051	3/8 SAE Washer	2	
	5140-13	FSC Control Assembly (Includes Items # 16, 18-20, F192 & F193)	*	F064	1/8 x 1/2 Woodruff Key (#3)	2	
21	5850-2	Handle Grip, Foam (5-1/2)	2	F068	1/8 x 1 Cotter Pin	1	
22	5212-2	Transmission Control Arm, LH	1	F069	3/32 x 1/2 Cotter Pin	1	
23	5213-2	Control Rod, LH (6")	1	F093	5/16-18 x 1 Hex Bolt	1	
24	5223	Extension Spring (1/4 x 5-1/2)	2	F134	AN960816L Washer	3	
25	5450	D-Clip	2	F146	1/4-20 Jam Nut	1	
26	5463	Steering Lever Actuator	2	F182	1/4 x 5/8 x 1/8 Washer	3	
27	5214-1	Bearing (.320 x .438 x .250)	2	F183	.312 x .700 x .074 Washer	2	
28	5391-3	Steering Lever Support	1	F186	5/64 x 1/2 Cotter Pin	1	
29	5217	Pivot Pin, Steering Lever	1	F188	1/4-20 Self-Locking Nut	4	
30	5451-3	Steering Lever Assembly, LH (Includes Items # 16, 21, 36, F188, F198 & F345)	1	F192	3/8-24 Self-Locking Nut	1	
	5451-5	Adjustable Steering Lever Arm, LH	*	F193	3/8 Belleville Spring Washer	3	
31	5219	FSC Extension Spring (3/4 x 6-3/4)	1	F198	.250 x .625 x .040 Washer, SS	2	
32	5280	Clevis (1/4)	1	F287	1/4-28 Keps Nut	2	
				F345	1/4-20 x .770 Knurled Bolt	4	
				F352	5/32 x 1 Hvy Duty Roll Pin	3	
				* Service Part Only			

Use only genuine **Walker**<sup>®</sup> replacement parts.

Effective Date 11-01-03

# STEERING CONTROL ASSEMBLIES

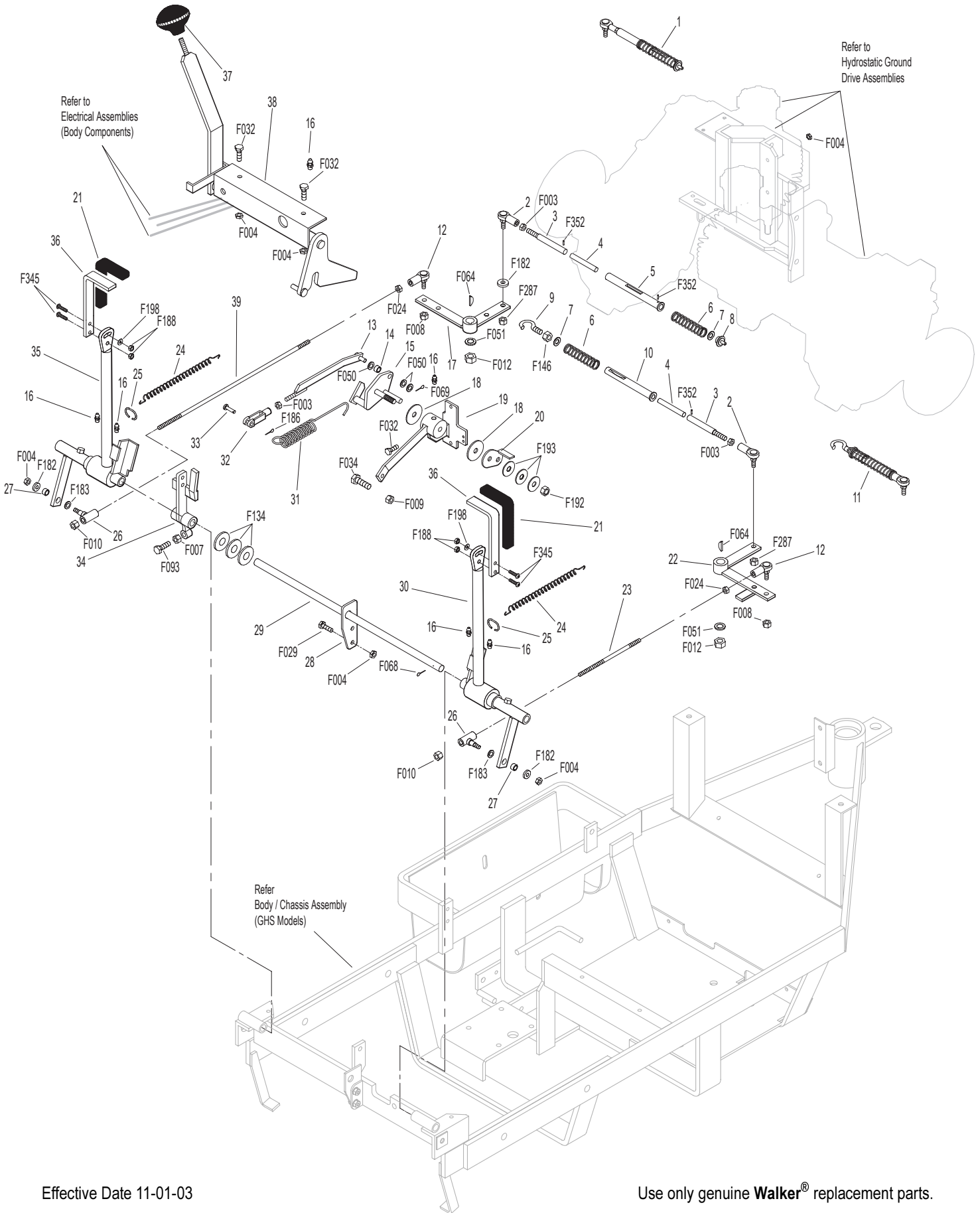

Effective Date 11-01-03

Use only genuine Walker® replacement parts.

# THROTTLE & CHOKE CONTROL ASSEMBLIES

ITEM NO.	PART NO.	DESCRIPTION	NO. REQ'D	ITEM NO.	PART NO.	DESCRIPTION	NO. REQ'D
<b>Throttle &amp; Choke Control Assemblies</b>				11	5108-6	Choke Control Knob, Black	1
1	8121-1	Throttle Cable	1	12	8123	Insulation Sleeve (3/8 x 6)	1
2	8122-1	Choke Cable	1	13	5975-3	Cable Tie (50# x 7")	1
3	5172	Nylon Bearing (.255 ID x .379 OD x .250)	2	14	5975-1	Cable Tie (18# x 3-3/4")	1
4	5108-7	Control Lock Tab	2	<b>Fasteners</b>			
5	5108-10	Friction Washer (.125)	2		F002	10-24 Keps Nut	6
6	5108-1	Control Lever, Throttle & Choke	2		F005	1/4-20 ESNA Nut	2
7	5108-5	Throttle Control Knob, Red	1		F025	10-24 x 3/8 PPHMS	4
8	5108-11	Friction Washer (.062)	2		F050	1/4 SAE Washer	2
9	5108-8	Control Bracket	2		F164	10-24-1/4 x 3/8 SHL Bolt	2
10	7108	Control Assembly, Throttle and Choke	2		F201	1/4 Belleville Spring Washer	4
	8121	Complete Throttle Control and Cable Assembly (Includes Item # 7)	*	* Service Part Only			
	8122	Complete Choke Control and Cable Assembly (Includes Item # 11)	*				

# THROTTLE & CHOKE CONTROL ASSEMBLIES

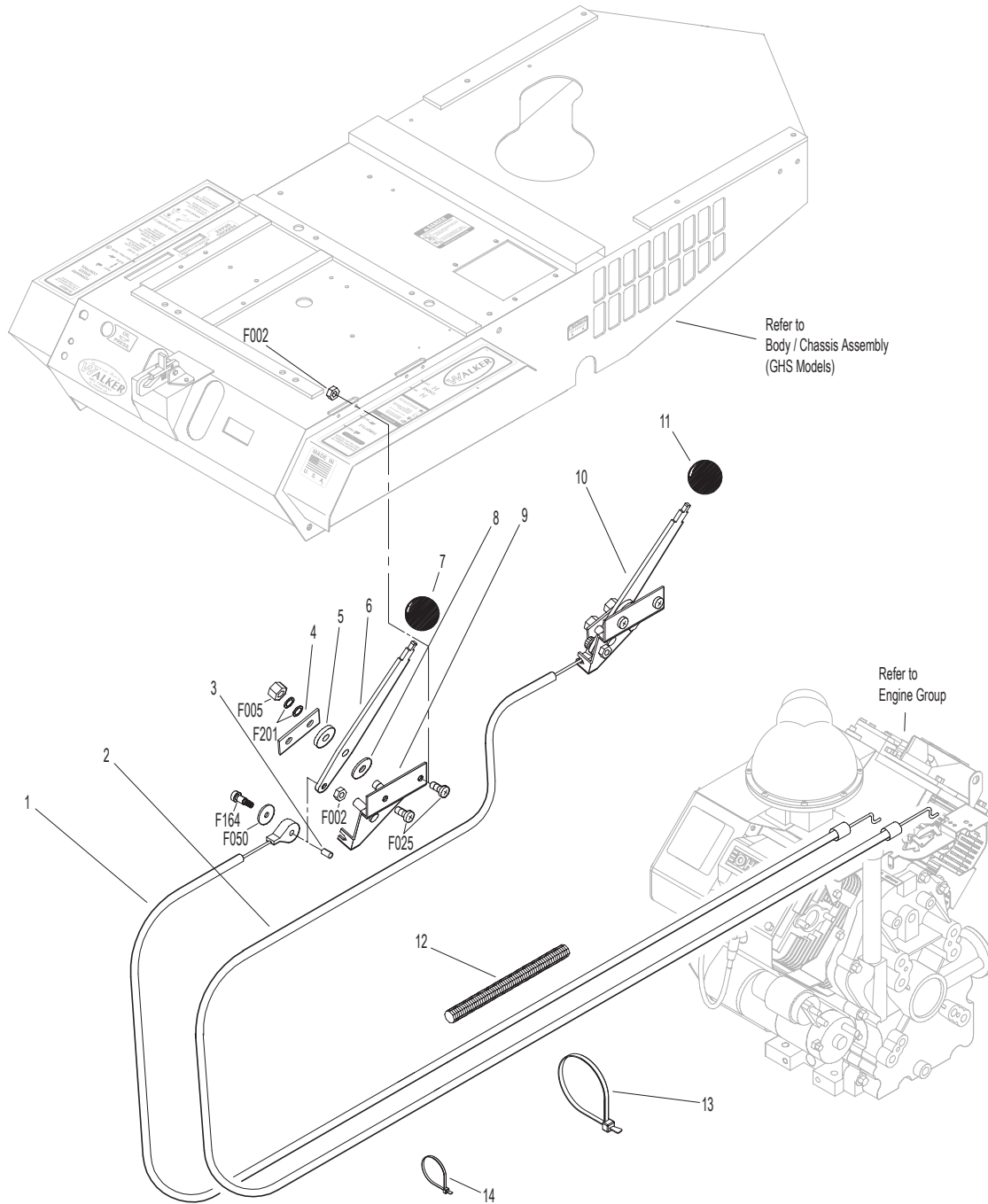

# PARKING BRAKE ASSEMBLY

ITEM NO.	PART NO.	DESCRIPTION	NO. REQ'D	ITEM NO.	PART NO.	DESCRIPTION	NO. REQ'D
<b>Parking Brake Assembly</b>				<b>Fasteners</b>			
1	7406-1	Handle Grip, Red	1	F002		10-24 Keps Nut	2
2	7406-8	Parking Brake Lever (4-1/4)	1	F003		1/4-28 Hex Nut	1
3	7406-2	Lever Mount	1	F004		1/4-20 Keps Nut	4
4	5830	Grease Fitting	1	F025		10-24 x 3/8 PPHMS	2
5	7407	Clevis Pin (3/16 x 1/2)	2	F029		1/4-20 x 1/2 Hex Bolt	3
6	7404	Brake Actuator Arm	2	F032		1/4-20 x 3/4 Hex Bolt	1
7	7405	Pin, Transmission Lock	2	F054		AN960616 Washer	1
8	7402	Clevis	2	F072		1/4 "E" Retainer Ring	2
9	7408	Compression Spring (1/2 x 3/4)	2	F086		#10 SAE Washer	4
10	7415	Rubber Dust Shield (5/8 x 3/8 x 1/32)	2	F109		1/8 x 5/8 Roll Pin	2
11	5567-3	O-Ring Seal (1/4 x 3/8)	4	F111		1/8 x 3/4 Cotter Pin	1
12	7403	Plunger Bushing, Gear Axle	2	F112		5/8 x 1-1/4 x .03 Washer	2
13	7404-1	Brake Actuator Mount	2	F127		1/16 x 1/2 Cotter Pin	4
14	7412	Clevis Pin (3/16 x 5/8)	2	F261		AN960616L Washer	6
15	5833	Cable Clamp (1/4)	2	F287		1/4-28 Keps Nut	1
16	7410	Brake Control Cable, LH (27")	1				
17	7409	Brake Control Cable, RH (21")	1				
18	7401-3	Cable Mount Bracket	1				
19	7401-1	Cable Pull Rod	1				
20	5552	Ball Joint (1/4-28)	1				



# PARKING BRAKE ASSEMBLY

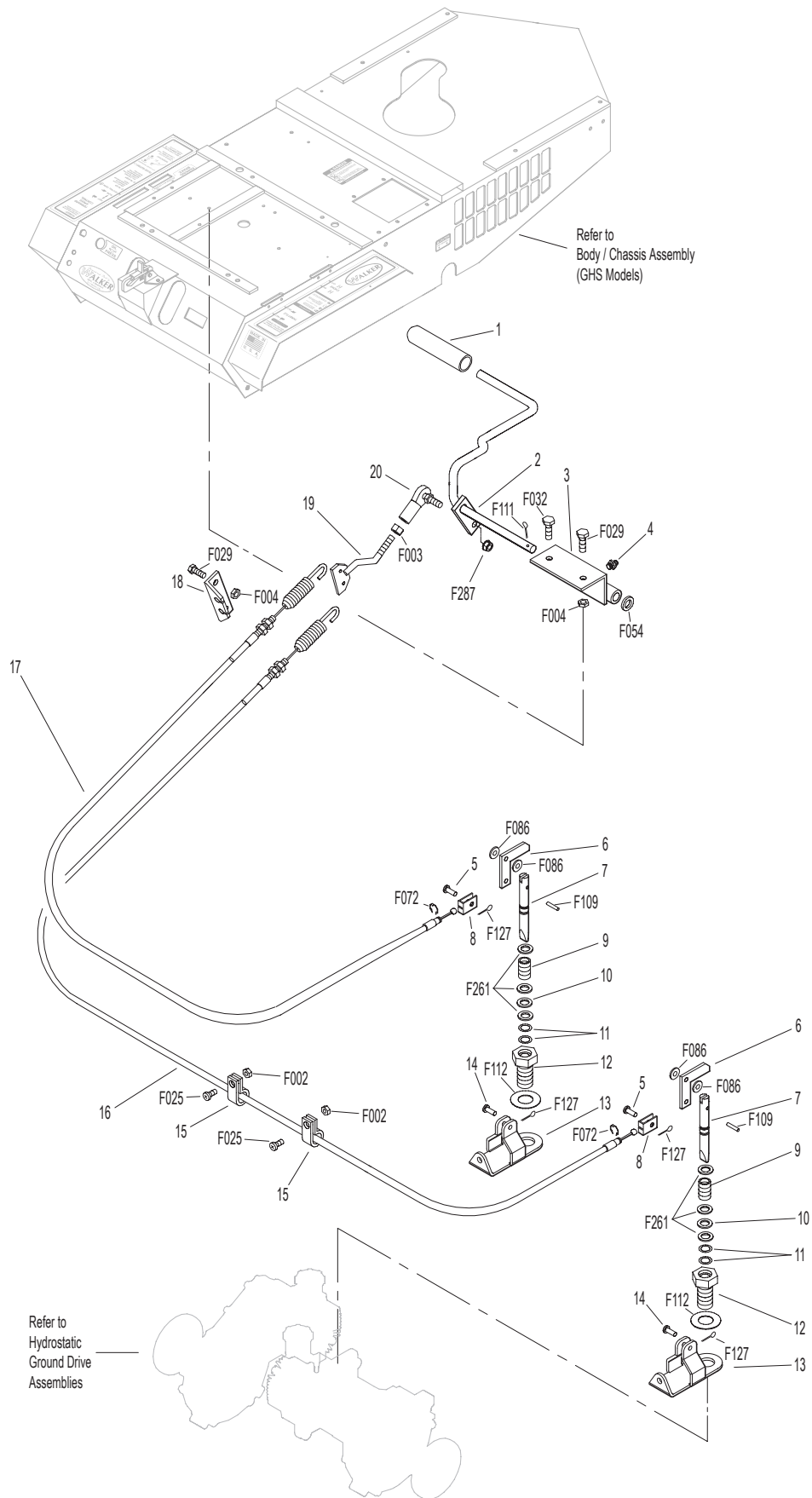

# GHS GROUP

ITEM NO.	PART NO.	DESCRIPTION	NO. REQ'D	ITEM NO.	PART NO.	DESCRIPTION	NO. REQ'D
<b>Delivery Chute Assembly</b>				<b>Fasteners</b>			
When Optional 9.5 Bushel Catcher Assembly is purchased, Item # 6 is replaced by P/N 8511-1 (Delivery Chute Assembly, 9.5).							
1	5515-2	Elbow Delivery Spout	1	F002		10-24 Keps Nut	8
2	5592-13	Backing Plate, Grass-Pak <sup>®</sup> Switch	1	F004		1/4-20 Keps Nut	6
3	5592-12	Mount Plate, Grass-Pak <sup>®</sup> Switch	1	F009		5/16-18 Whiz Locknut	1
4	5578	Rear Clip, Chute Mount	1	F012		3/8-16 Keps Nut	3
5	5577	Side Clip, Chute Mount	2	F025		10-24 x 3/8 PPHMS	2
6	5511-3	Delivery Chute, with Clips, 6.7 (Includes Items # 4, 5, 7, F079 & F085)	1	F026		10-24 x 1/4 PPHMS	2
	8511-1	Delivery Chute, with Clips, 9.5 (Includes Items # 4, 5, 7, F079 & F085)	*	F034		5/16-18 x 3/4 Hex Bolt	1
7	5578-10	Front Clip, Chute Mount	1	F038		3/8-16 x 1 Hex Bolt	1
8	6530-4	Body Chute (10")	1	F040		3/8-16 x 1-1/2 Hex Bolt	1
<b>Blower Belt Tightener Assembly</b>							
9	7238-1	Blower Drive Pulley (Mirco-V)	1	F042		3/8-16 x 2-1/4 Hex Bolt	1
10	7234-1	Blower Belt (Micro-V)	1	F054		AN960616 Washer	1
11	7239-1	Blower Pulley (Mirco-V)	1	F067		3/16 x 3/16 x 1 Key	1
12	7364-2	Torsion Spring	1	F074		1/4-20 x 3/8 Set Screw	2
13	5830-3	Grease Fitting (45 Deg.)	1	F075		5/16-18 x 1/2 SQH Set Screw	1
14	7364-1	Blower Belt Tightener Arm	1	F079		A/A66D Aluminum Pop Rivet	12
15	7201-4	Inner Race (1-1/2)	1	F085		3/16 Rivet Backup Washer	12
16	7201-3	DU Bearing	1	F102		10-24 x 1-1/2 PTHMS	2
17	5841	Retainer Washer	1	F114		5/16-18 x 5/8 SQH Set Screw	2
18	5245	Idler Pulley, 3"	1	F128		10-24 x 3/8 PTHMS	4
<b>Blower Assembly</b>							
19	5268	Bearing with Collar (3/4)	2	F163		5/16-18 x 3/4 SQH Set Screw	1
20	6543	Housing (10" Blower)	1	F217		7/16-14 Hex Nut	1
	6542	Blower Assembly (10")	*	F218		7/16 Split Lock Washer	1
21	6545	Blower Wheel (10")	1	F219		7/16-14 x 1-1/4 Hex Bolt	1
22	6525-2	Faceplate (10" Blower)	1	F231		1/4 x 3/4 Woodruff Key (# 806)	1
23	6526	Intake Tube (6-1/2 x 2-1/2)	1	F362		A/A62D Alum. Pop Rivet (3/16D x 13/32L)	2
24	5595-2	Intake Cover	**				
25	7528	Skid Bar (10" Blower)	1				
26	7833	Cable Clamp (7/8 x 1/4)	1				

\* Service Part Only

\*\* Plugs Blower when GHS is not in use. Furnished only with Mulching Decks, SD Decks used on a GHS Tractor, Rotary Broom Attachment and Snowblower Attachment. Use of this part may be replaced by installing Blower Lockout Kit (P/N 6541). See Page 50.

# GHS GROUP

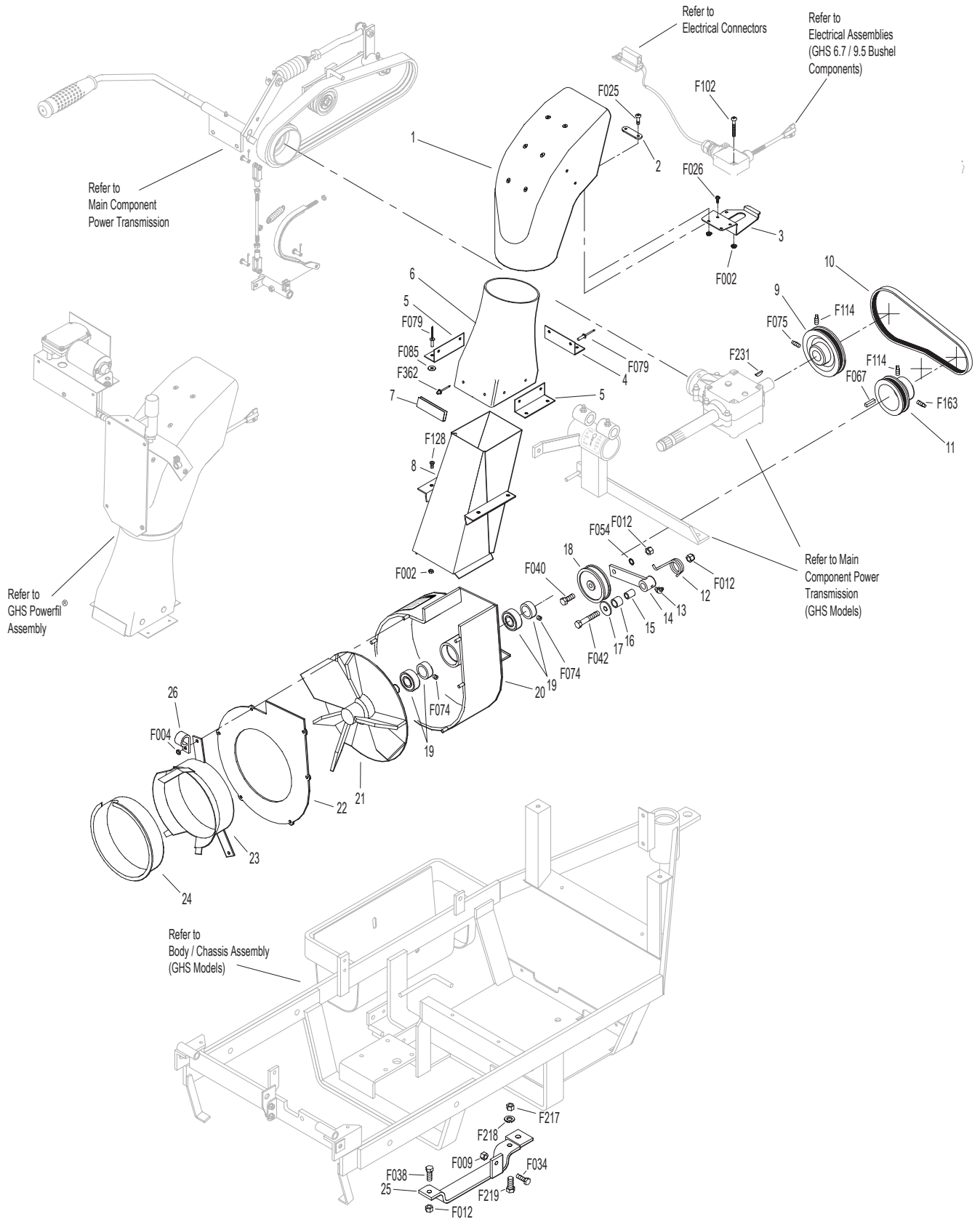

Effective Date 11-01-03

Use only genuine Walker® replacement parts.

# GHS POWERFIL® ASSEMBLY

ITEM NO.	PART NO.	DESCRIPTION	NO. REQ'D	ITEM NO.	PART NO.	DESCRIPTION	NO. REQ'D
<b>GHS Powerfil® Assembly</b>				<b>Fasteners</b>			
1	5557	Motor Mount, Powerfil®	1	F002		10-24 Keps Nut	8
2	5551-3	Bearing Cap, Powerfil®	1	F003		1/4-28 Hex Nut	4
3	5551-1	Pivot Bearing (#S3PP)	2	F025		10-24 x 3/8 PPHMS	1
4	5552	Ball Joint (1/4-28)	2	F054		AN960616 Washer	1
5	5518-2	Pivot, Delivery Spout	1	F061		1/4 Internal Star Lock Washer	1
6	5517-2	Pivot Mount	1	F085		3/16 Rivet Backup Washer	1
7	5558-1	Powerfil® Pushrod	1	F101		10-24 x 1-1/4 SHC Screw	1
8	5553-3	Bushing, Powerfil® Actuator	4	F109		1/8 x 5/8 Roll Pin	1
9	5558-2	Powerfil® Actuator Rod	1	F129		10-24 x 1/2 PTHMS	7
	5549	Actuator Rod Assembly (Includes Items # 4, 7-10 & F003)	*	F261		AN960616L Washer	1
10	5553-1	1/2 x 2-1/4 Compression Spring	2	F287		1/4-28 Keps Nut	1
11	5554	Actuator Arm	1	* Service Part Only			
12	5519-3	Motor Mount Nut (5/8-24 Panel Nut)	*				
13	5519-2	Motor Mount Washer	*				
14	5519	Actuator Motor (12/24V) (Includes Items # 12 & 13)	1				
15	5977	Grommet (1/2 ID x 7/8 OD x 1/16)	1				

Use only genuine **Walker®** replacement parts.

Effective Date 11-01-03

# GHS POWERFIL® ASSEMBLY

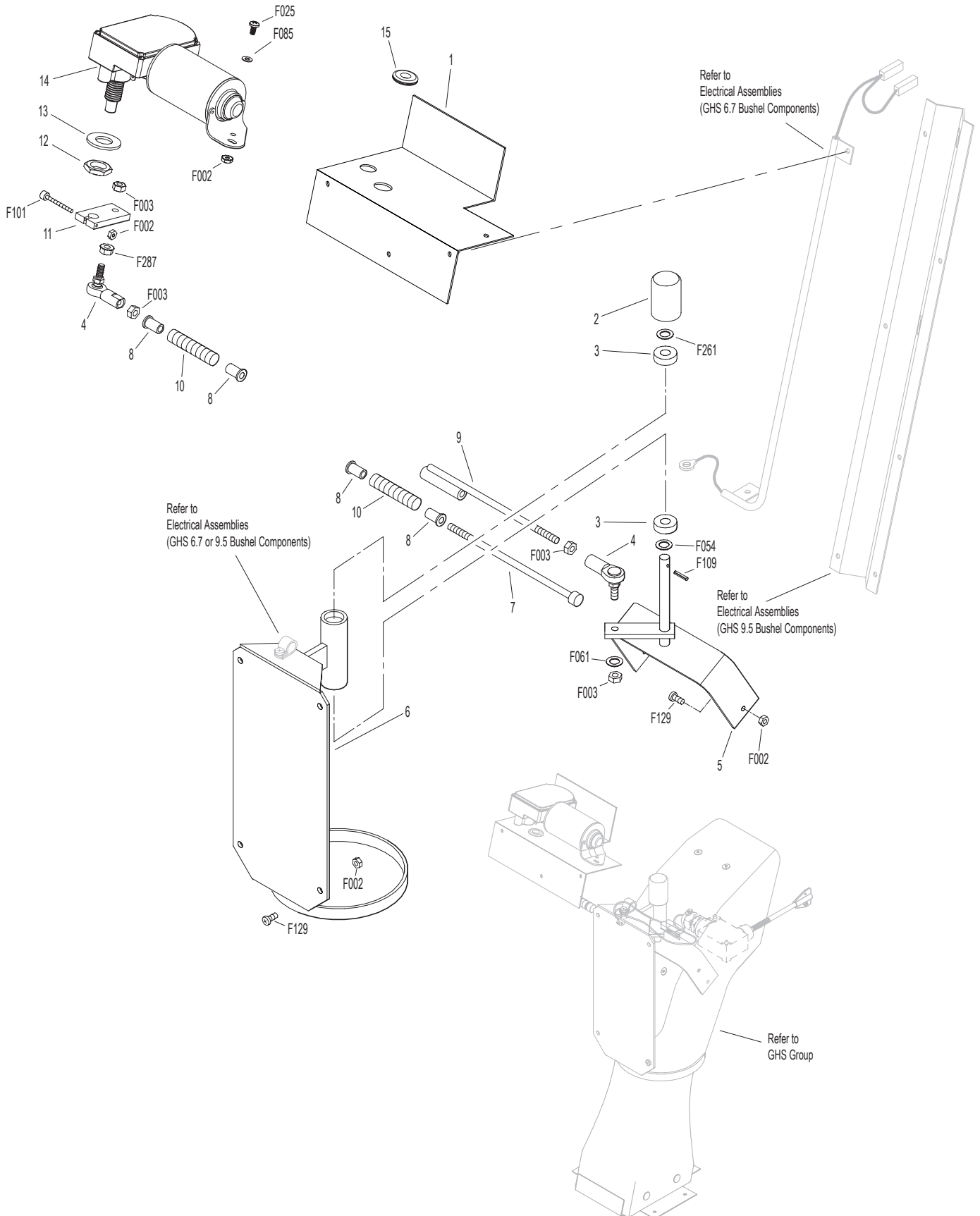

# GHS 6.7 BUSHEL CATCHER & EXHAUST DEFLECTOR ASSEMBLIES

ITEM NO.	PART NO.	DESCRIPTION	NO. REQ'D	ITEM NO.	PART NO.	DESCRIPTION	NO. REQ'D
<b>Upper Baffle Screen Assembly (Removable)</b>				27	7532	Handle, Catcher Lift	2
					7534	Catcher Handle Kit (Includes Items # 27, 28, F004 & F172)	**
1	7509-3	Channel Bottom	2	28	7533	Backing Plate, Handle	2
2	7505	Mustache Spring	2	29	5155-15	Box Support, Gas Spring	2
3	6507	Screen Seal, 6.7 (24")	1	30	6508	Safety Latch	1
4	6856-1	Edge Molding, 6.7 (21-3/4)	1	31	5522-2	Hinge Backup Plate, RH	1
5	7509-2	Channel Top	2	32	5584	Reinforcing Strap	2
6	6512-2	Removable Screen (6.7) (Includes Items # 4, 7, F025 & F190)	1*	<b>5598 Optional Dump Bag (Not Shown)</b> May be ordered as an option. Contact your Walker dealer.			
7	7506	Knob (10-24) Threaded Insert	2				
8	6509-4	C-Channel (6.7)	1				
<b>Exhaust Deflector Assembly</b>				<b>Fasteners</b>			
	5504	Exhaust Deflector Kit, 6.7	**	F002		10-24 Keps Nut	23
9	5504-3	Hinge (22")	1	F004		1/4-20 Keps Nut	16
10	5504-1	Exhaust Deflector (2 Piece / 6.7)	1	F009		5/16-18 Whiz Locknut	2
11	5504-8	Deflector Mount Doubler	2	F020		5/16-18 ESNA Nut	2
<b>GHS 6.7 Bushel Catcher Assembly</b>				F025		10-24 x 3/8 PPHMS	4
12	5583	Handle	1	F026		10-24 x 1/2 PPHMS	8
13	5588	Rubber Bumper (.75 OD x .50)	2	F027		10-24 x 5/8 PPHMS	4
14	5130	Side Strap, Door (6.7)	2	F035		5/16-18 x 1-1/4 Hex Bolt	1
15	5514-10	Door Frame, Gas Spring (6.7)	1	F037		10-24 x 5/8 PTH Screw	4
16	5510-1	6.7 Bushel Catcher, with Door	1	F049		5/16 SAE Washer	5
	5502-1	6.7 Catcher, W/O Powerfil®, w/ Door & Deflector	***	F061		1/4 Internal Star Lock Washer	2
	5502-2	6.7 Catcher w/Powerfil®, Door & Deflector	***	F079		A/A66D Aluminum Pop Rivet	11
17	5503	Mounting Frame, Catcher (6.7)	1	F085		3/16 Rivet Backup Washer	21
18	5513-1	Mounting Frame Doubler (6.7)	1	F129		10-24 x 1/2 PTHMS	10
19	5522-1	Hinge Backup Plate, LH	1	F172		1/4-20 x 3/4 Carriage Bolt	4
20	5155-12	5/16 Ball Stud	2	F188		1/4-20 Self Locking Nut	17
21	5147	Spring Clip	4	F195		1/4-20 x 3/4 PPHMS SS	8
22	5155-2	Gas Spring Cover	2	F196		1/4-20 x 1 PPHMS SS	2
23	5155	Catcher Gas Spring Assembly (Includes Items # 20, 21, 25 & F049)	2	F198		.625 x .250 x .040 Washer, SS	9
24	5524-1	Flanged Hinge Bearing	2	F203		1/4-20 x 5/8 PPHMS SS	4
25	5155-13	3/4 Ball Stud	2	F230		1/4-20 x 1-1/4 PPHMS SS	1
26	5523-6	Gas Spring Plate	2	F242		1/4-20 x 7/8 PPHMS SS	14
				F252		10-24 x 3/4 PPHMS	1
				F255		5/16-18 x 1-1/2 Hex Bolt	1
				F329		.260 ID x 1.939 OD Washer	2
				F330		3/16 D x 21/32 L Rivet, SS	2
				F351		Aluminum Pop Rivet	6

\* This screen can be replaced by P/N 6512-3 Removable Screen (3/4" holes) for improved air flow performance in wet conditions.

\*\* This kit is sold as a complete assembly, including mounting hardware.

\*\*\* Service Part Only

# GHS 6.7 BUSHEL CATCHER & EXHAUST DEFLECTOR ASSEMBLIES

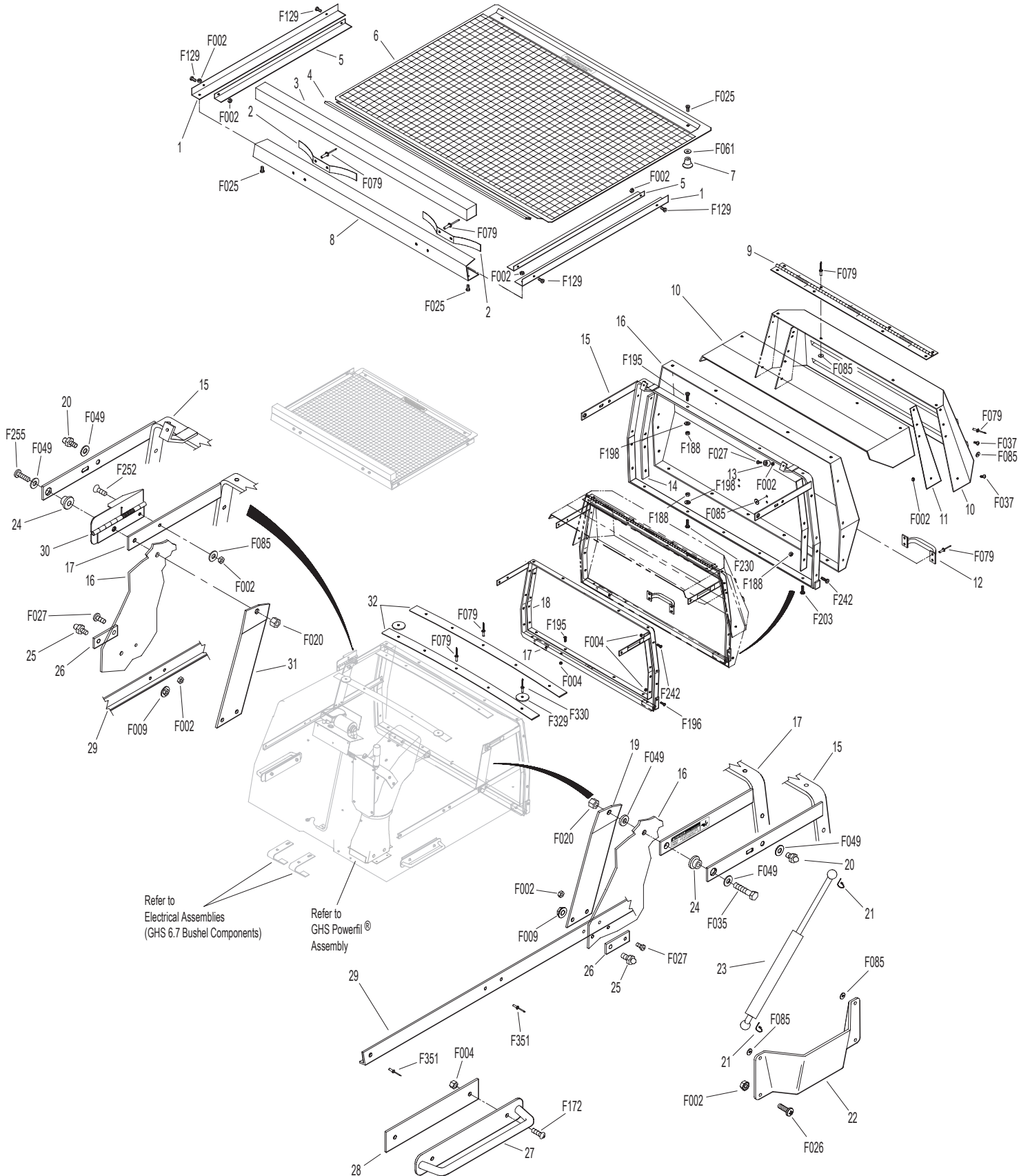

# GHS 9.5 BUSHEL CATCHER & EXHAUST DEFLECTOR ASSEMBLIES

ITEM NO.	PART NO.	DESCRIPTION	NO. REQ'D	ITEM NO.	PART NO.	DESCRIPTION	NO. REQ'D
<b>Upper Baffle Screen Assembly (Removable)</b>				30	7532	Handle, Catcher Lift	2
1	7509-3	Channel Bottom	2		7534	Catcher Handle Kit (Includes Items # 29, 30, F004 & F172)	*
2	7505	Mustache Spring	2	31	5155-15	Box Support, Gas Spring	2
3	7507	Screen Seal (27-1/2)	1	32	7508	Safety Latch (7.0 / 9.5)	1
4	7856-1	Edge Molding (26")	1	33	5522-2	Hinge Backup Plate, RH	1
5	7509-2	Channel Top	2	34	7584	Reinforcing Strap	2
6	7512-2	Removable Screen (7.0 / 9.5) (Includes Items # 4, 7, F025 & F190)	1****	<b>5598 Optional Dump Bag (Not Shown)</b> May be ordered as an option. Contact your Walker dealer.			
7	7506	Knob (10-24) Threaded Insert	2	<b>Fasteners</b>			
8	7509-4	C-Channel (7.0 / 9.5)	1	F002	10-24 Keps Nut		15
<b>Exhaust Deflector Assembly</b>				F004	1/4-20 Keps Nut		19
	7504	Exhaust Deflector Kit, 7.0 / 9.5	*	F009	5/16-18 Whiz Locknut		2
9	7504-3	Hinge (27")	1	F020	5/16-18 ESNA Nut		2
10	7504-1	Exhaust Deflector (Two Piece)	1	F025	10-24 x 3/8 PPHMS		4
11	7504-8	Deflector Mount Doubler	2	F026	10-24 x 1/2 PPHMS		8
<b>GHS 9.5 Bushel Catcher Assembly**</b>				F027	10-24 x 5/8 PPHMS		4
12	5583	Handle	1	F035	5/16-18 x 1-1/4 Hex Bolt		1
13	8516	Side Strap, Door / 9.5	2	F037	10-24 x 5/8 PTH Screw		2
14	5588	Rubber Bumper (.75 OD x .50)	2	F049	5/16 SAE Washer		4
15	7514-1	Backup Plate	1	F061	1/4 Internal Star Lock Washer		2
16	8514-11	9.5 Door Frame	1	F079	A/A66D Aluminum Pop Rivet		33
17	8510-1	9.5 Bushel Catcher Box (Includes Door)	1	F085	3/16 Rivet Backup Washer		24
	8502-1	9.5 Catcher W/O Powerfil®, Door & Deflector	***	F129	10-24 x 1/2 PTHMS		14
	8502-2	9.5 Catcher Assembly (Includes Powerfil®, Door & Deflector)	***	F172	1/4-20 x 3/4 Carriage Bolt		4
	8502-4	9.5 Catcher Assembly w/Frame	***	F188	1/4-20 Self Locking Nut		20
18	8513-3	9.5 Mount Frame Doubler	1	F195	1/4-20 x 3/4 PPHMS SS		8
19	8503-2	9.5 Mounting Frame	1	F196	1/4-20 x 1 PPHMS SS		3
20	5522-1	Hinge Backup Plate, LH	1	F198	.625 x .250 x .040 Washer, SS		5
21	7503-9	Pivot Bushing (5/16 x 5/8)	2	F230	1/4-20 x 1-1/4 PPHMS SS		1
22	5155-12	5/16 Ball Stud	2	F242	1/4-20 x 7/8 PPHMS SS		23
23	5147	Spring Clip, Gas Spring	4	F252	10-24 x 3/4 PPHMS		1
24	5155-2	Gas Spring Cover	2	F255	5/16-18 x 1-1/2 Hex Bolt		1
25	5155	Catcher Gas Spring Assembly (Includes Items # 22, 23, 27 & F049)	2	F329	.260 ID x 1.939 OD Washer		2
26	5524-1	Flanged Hinge Bearing	2	F330	3/16 D x 21/32 L Rivet, SS		2
27	5155-13	3/4 Ball Stud	2	F351	Aluminum Pop Rivet		6
28	5523-6	Gas Spring Plate	2	* This kit is sold as a complete assembly, including mounting hardware.			
29	7533	Backing Plate, Handle	2	** May be ordered as a factory-installed option. Contact your Walker dealer.			
				*** Service Part Only			
				**** This screen can be replaced by P/N 7512-3 Removable Screen (3/4" holes) for improved air flow performance in wet conditions.			

Use only genuine **Walker®** replacement parts.

Effective Date 11-01-03





# ELECTRICAL ASSEMBLIES (CHASSIS COMPONENTS)

ITEM NO.	PART NO.	DESCRIPTION	NO. REQ'D	ITEM NO.	PART NO.	DESCRIPTION	NO. REQ'D
<b>Battery Assembly</b>				<b>Fasteners</b>			
1	5932	Battery Terminal Insul., Black (-)	1	F002		10-24 Keps Nut	10
2	5975-1	Cable Tie (18# x 3-3/4")	2	F004		1/4-20 Keps Nut	5
3	5933	Battery Terminal Insul., Red (+)	1	F009		5/16-18 Whiz Locknut	1
4	5910	Battery (12V U1-SP30, Dry)	1	F019		1/4-20 ESNA Wing Nut	2
5	5844	Battery Hold-Down Bar	1	F025		10-24 x 3/8 PPHMS	1
6	6392	Battery Protector Plate	1	F026		10-24 x 1/2 PPHMS	3
7	5839	Hook Bolt	2	F027		10-24 x 5/8 PPHMS	2
8	6390	Battery Pan	1	F031		1/4-20 x 5/8 Hex Bolt	2
9	6923	Negative Battery Cable	1	F032		1/4-20 x 3/4 Hex Bolt	3
10	8943	Positive Battery Lead Wire	1	F050		1/4 SAE Washer	6
<b>Harness Assembly</b>				F093		5/16-18 x 1 Hex Bolt	1
				F129		10-24 x 1/2 PTHMS	1
11	8941	Circuit Breaker (30 Amp) Auto Reset / Sealed	1	<b>NOTE:</b> Refer to <b>ELECTRICAL CONNECTORS</b> , Page 40 for identification of all Electrical Wiring Service Parts.			
12	7672	Mount Bracket	1				
13	7948-1	Time Delay Module	1				
14	6941	Relay Switch (30/40 Amp)	1				
15	7948-5	Time Delay Harness	1				
16	5975-3	Cable Tie (50# x 7")	6				
17	5942-5	Safety Switch (NO)	2				
18	5833	Cable Clamp (1/4)	1				
19	6940-4	Wire Harness	1				

# ELECTRICAL ASSEMBLIES (CHASSIS COMPONENTS)

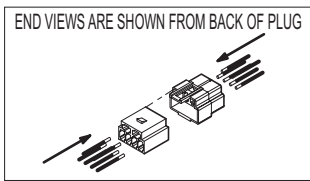
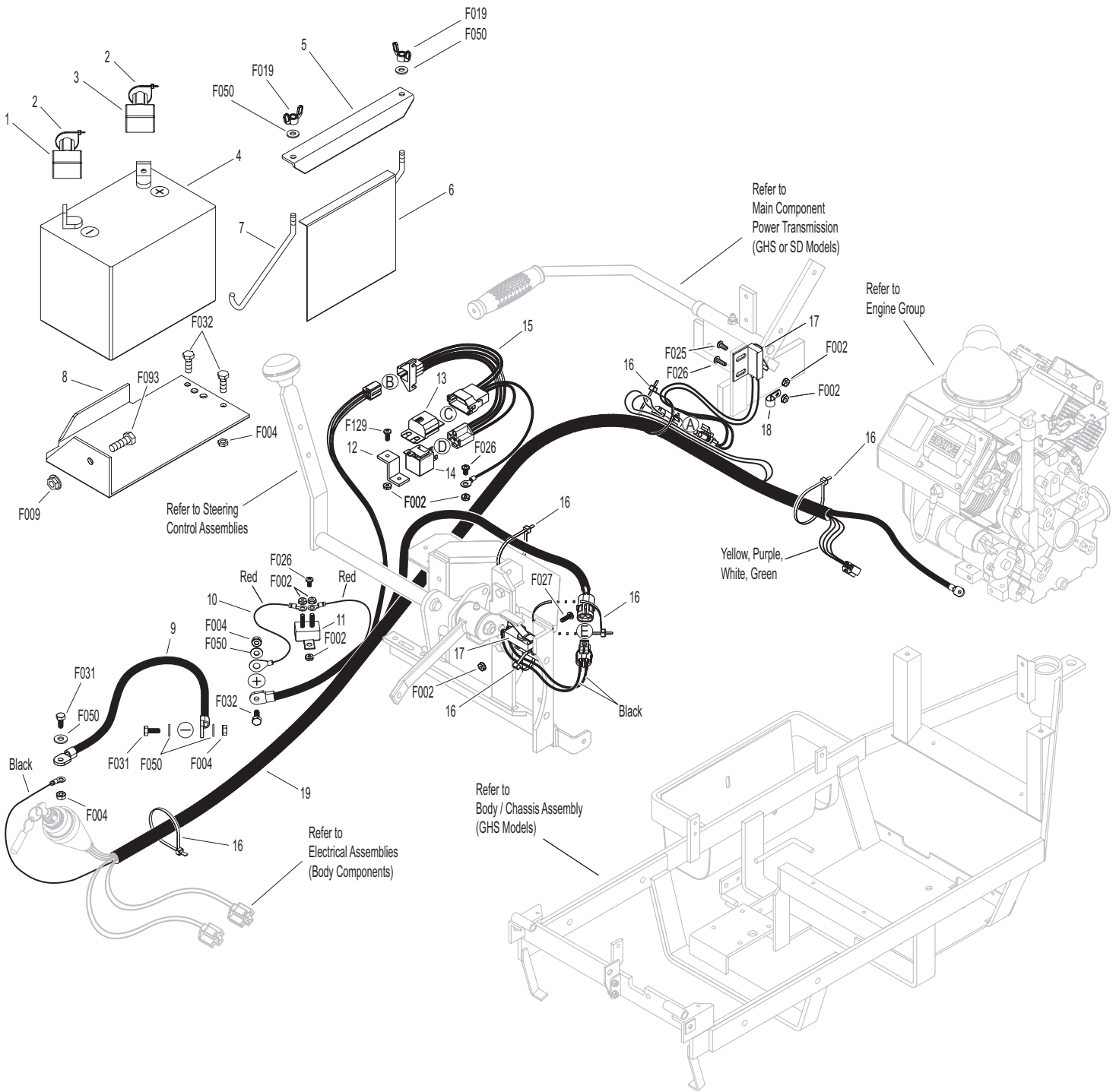

DETAIL A



DETAIL B

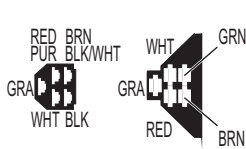

DETAIL C

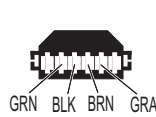

DETAIL D



DETAIL E



# ELECTRICAL ASSEMBLIES (BODY COMPONENTS)

ITEM NO.	PART NO.	DESCRIPTION	NO. REQ'D	ITEM NO.	PART NO.	DESCRIPTION	NO. REQ'D
<b>Electrical Assemblies (Body Components)</b>				<b>Fasteners</b>			
1	8960-2	Ignition Key (1 Set)	1		F002	10-24 Keps Nut	4
2	8960-15	Ignition Switch (with Keys) (Includes Items # 1, 20 & F349)	1		F025	10-24 x 3/8 PPHMS	3
3	5940-3	Ignition Switch Cover	1		F026	10-24 x 1/2 PPHMS	1
4	5975-3	Cable Tie (50# x 7")	3		F349	Washer .835 ID 1.122 OD, SS	1
5	5983	Power Lead Wire, Body	1	* Service Part Only			
6	5975-5	Wire Clip, Self-Mount	1	<b>NOTE:</b> Refer to <b>ELECTRICAL CONNECTORS</b> , Page 40 for identification of all Electrical Wiring Service Parts.			
7	5941-5	Safety Switch	1				
8	7203-6	Riser Plate	1				
9	5977-6	Grommet (1 x 1-1/4)	1				
10	6940-10	Jumper Wire	1				
11	8996-4	Red Indicator Lens (Includes Item # 12)	1				
12	8996-3	Indicator Bulb (Replacement for P/N 8996)	*				
13	8996-2	Red Indicator Light Assembly (Includes Items # 11 & 12)	1				
14	5991-1	Hourmeter Power Lead Wire	1				
15	8990-1	Hourmeter (SenDec)	1				
16	5991-2	Hourmeter Ground Wire	1				
17	6941	Relay Switch (30/40 Amp)	2				
18	7941-5	Circuit Breaker (7 Amp) (Includes Item # 19)	1				
19	7941-3	Boot, Circuit Breaker	1				
20	7854	Plastic Tip / Red	1				

# ELECTRICAL ASSEMBLIES (BODY COMPONENTS)

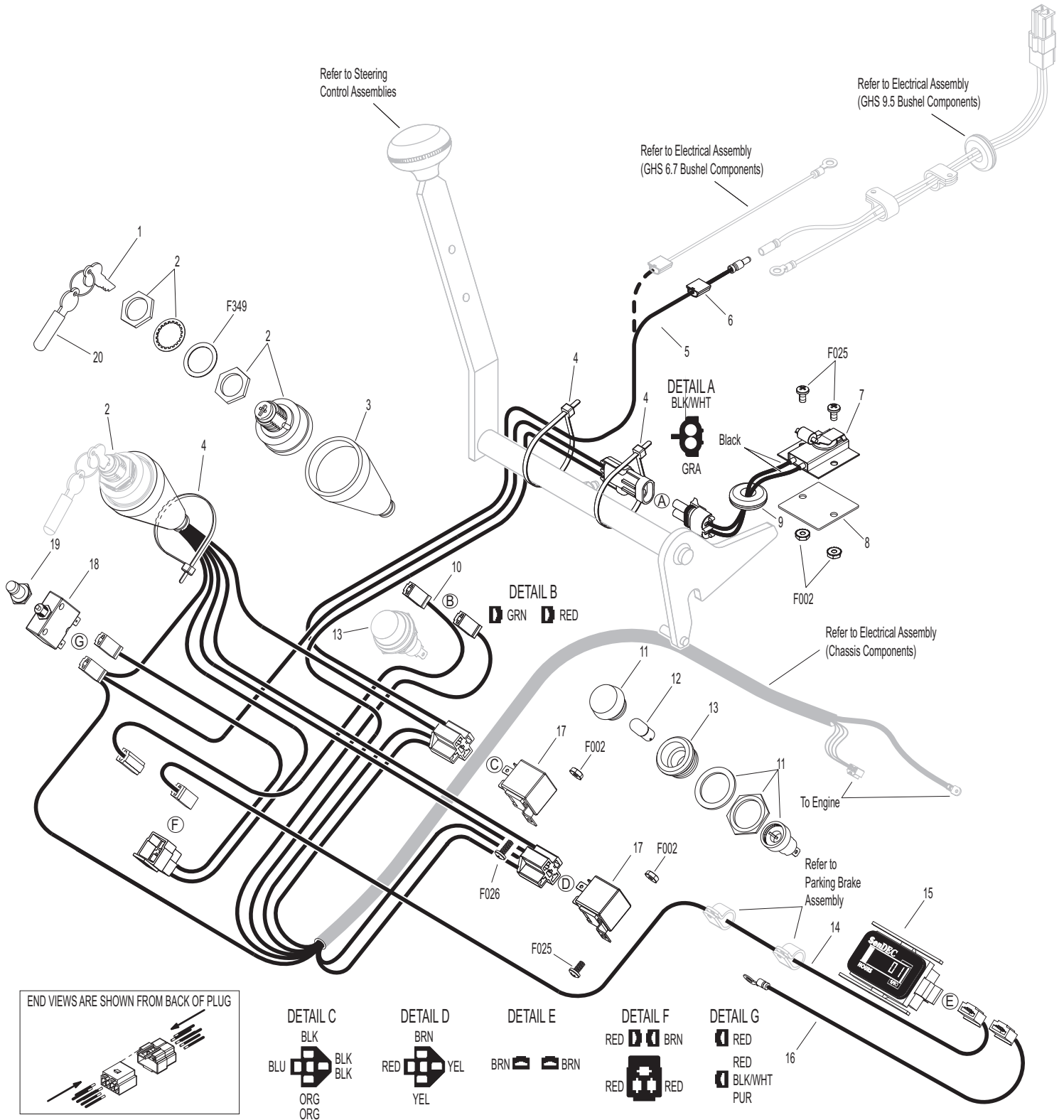

Effective Date 11-01-03

Use only genuine **Walker**® replacement parts.

# ELECTRICAL ASSEMBLIES (GHS 6.7 BUSHEL COMPONENTS)

ITEM NO.	PART NO.	DESCRIPTION	NO. REQ'D	ITEM NO.	PART NO.	DESCRIPTION	NO. REQ'D
<b>Horn &amp; Powerfil® Wiring Assemblies</b>				<b>Fasteners</b>			
1	5599	Pigtail Wire Set, Horn	1	F002		10-24 Keps Nut	11
2	5857	Wire Clamp (1/8 J-Clip)	1	F025		10-24 x 3/8 PPHMS	1
3	5975-3	Cable Tie (50# x 7")	2	F037		10-24 x 5/8 PTH Screw	1
4	5536-2	Horn, Full Signal	*	F085		3/16 Rivet Backup Washer	1
5	5984	Electric Contact Spring	2	F086		#10 SAE Washer	1
6	5982-2	Insulator Bushing, Plastic	1	F129		10-24 x 1/2 PTHMS	3
7	5982-1	Insulator Washer, Plastic (2")	1	F144		4-40 x 1/4 PPHMS	1
8	5985-2	Power Lead Wire, Catcher	1	F145		4-40 Keps Nut	1
9	5988-1	Conduit Assembly, Powerfil®	1	F147		10-24 x 1/2 PPHMS SS	3
	5988-4	Powerfil® Tube & Wire Assembly (Includes Item # 8)	*	F148		10-24 x 3/8 PPHMS SS	3
<b>Grass-Pak® Switch Assembly</b>				* Service Part Only			
10	5833	Cable Clamp (1/4)	2	<b>NOTE:</b> Refer to <b>ELECTRICAL CONNECTORS</b> , Page 40 for identification of all Electrical Wiring Service Parts.			
11	5980-3	Wire, Grass-Pak® Switch	1				
12	5592-11	Liquid Tight Plug	1				
13	5592-10	Grass-Pak® Switch Module	1				
	5592-4	Grass-Pak® Switch Assembly (Includes Items # 3 & 10-14)	*				
14	5594-5	Vane Assembly, Grass-Pak® Switch (Includes Items # F144 & F145)	1				

# ELECTRICAL ASSEMBLIES (GHS 6.7 BUSHEL COMPONENTS)

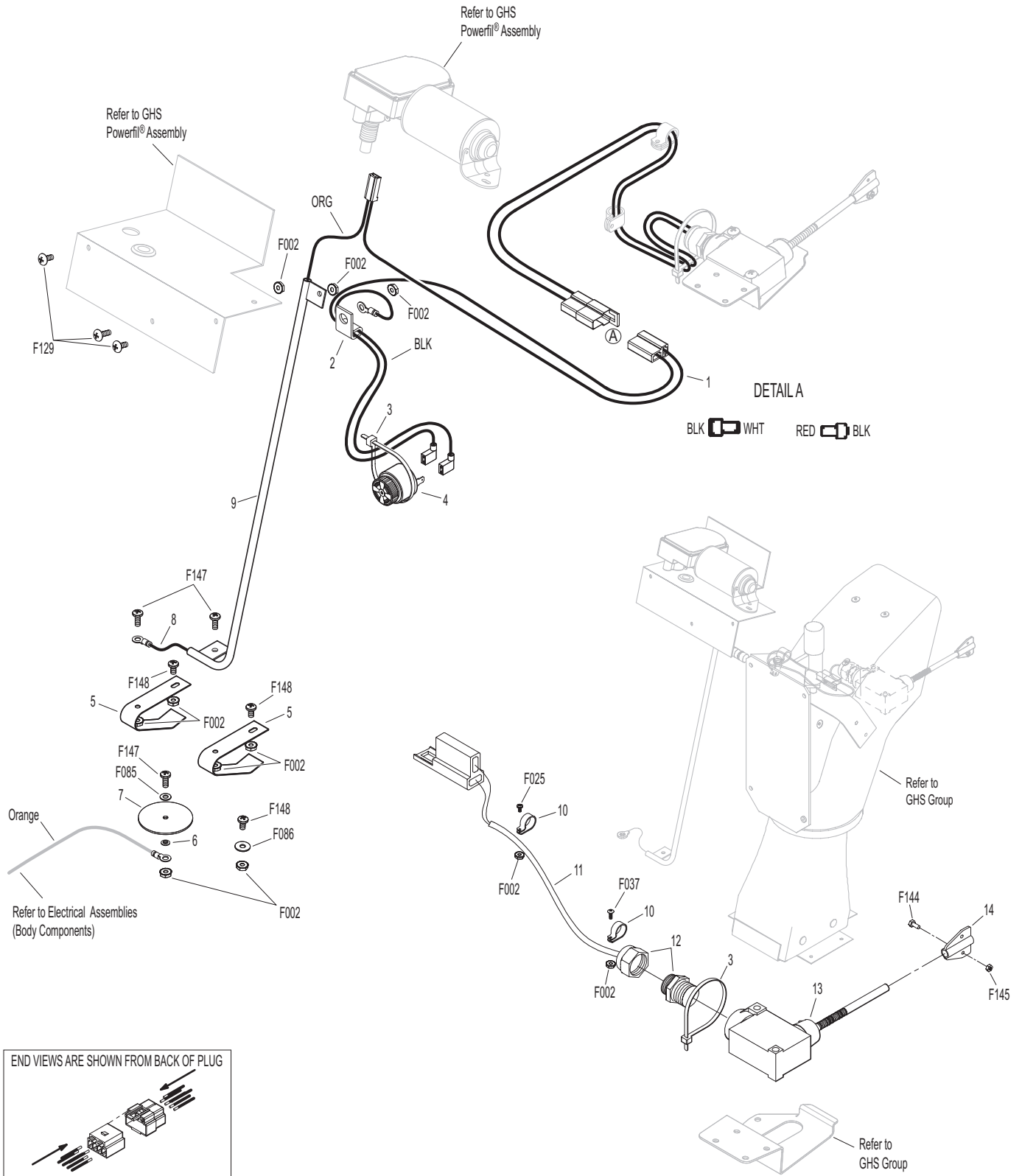

Effective Date 11-01-03

Use only genuine **Walker®** replacement parts.

# ELECTRICAL ASSEMBLIES (GHS 9.5 BUSHEL COMPONENTS)

ITEM NO.	PART NO.	DESCRIPTION	NO. REQ'D	ITEM NO.	PART NO.	DESCRIPTION	NO. REQ'D
<b>Horn &amp; Harness Channel Assemblies</b>				<b>Fasteners</b>			
1	5976	Grommet (3/8 x 11/16)	2	F002		10-24 Keps Nut	10
2	5975-3	Cable Tie (50# x 7")	2	F025		10-24 x 3/8 PPHMS	1
3	5536-2	Horn, Full Signal	*	F037		10-24 x 5/8 PTH Screw	3
4	8117	9.5 Wire Harness Channel	1	F079		A/A66D Aluminum Pop Rivet	4
<b>Harness &amp; Grass-Pak® Switch Assemblies</b>				F085		3/16 Rivet Backup Washer	4
5	5833	Cable Clamp (1/4)	4	F129		10-24 x 1/2 PTHMS	6
6	5977-2	Grommet, Cut (1/8 x 3/8)	2	F144		4-40 x 1/4 PPHMS	1
7	8950-1	Extension Wire	1	F145		4-40 Keps Nut	1
8	7835	Frame Clip (3/16)	2	* Service Part Only			
9	7834	Nylon Clamp (1/4)	4	<b>NOTE:</b> Refer to <b>ELECTRICAL CONNECTORS</b> , Page 40 for identification of all Electrical Wiring Service Parts.			
10	8950	Wire Harness, 9.5 Catcher	1				
11	5980-3	Wire, Grass-Pak® Switch	1				
12	5592-11	Liquid Tight Plug	1				
13	5592-10	Grass-Pak® Switch Module	1				
	5592-4	Grass-Pak® Switch Assembly (Includes Items # 2, 5 & 11-14)	*				
14	5594-5	Vane Assembly, Grass-Pak® Switch (Includes Items # F144 & F145)	1				



# ELECTRICAL ASSEMBLIES (GHS 9.5 BUSHEL COMPONENTS)

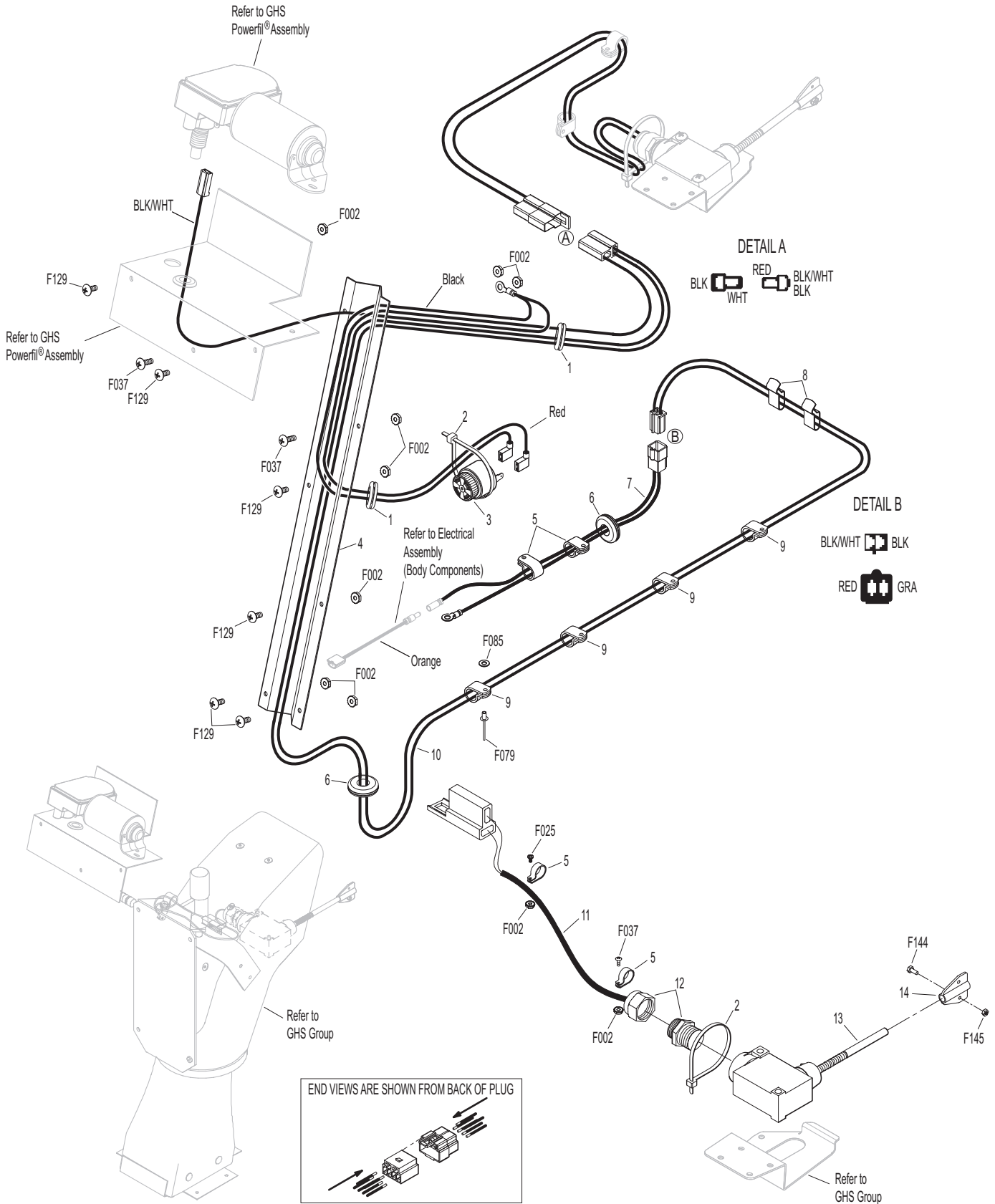

Effective Date 11-01-03

Use only genuine **Walker®** replacement parts.

# ELECTRICAL CONNECTORS

ITEM NO.	PART NO.	DESCRIPTION	NO. REQ'D	ITEM NO.	PART NO.	DESCRIPTION	NO. REQ'D
<b>Electrical Wiring Service Parts</b>				29	7942-1	2-Way Locking Connector, Female	*
1	5996-1	16-14 GA Butt Connector	*	30	7942-2	2-Way Connector, Male	*
2	5996-11	12-10 GA Butt Connector	*	31	7942-3	2-Way Connector, Female	*
3	7942-14	14-16 GA Shrink Connector	*	32	7942-10	2-Way Locking Connector, Male	*
4	7942-13	10-12 GA Shrink Connector	*	33	5940-8	3-Way Connector, Male	*
5	5995-1	Wire Terminal Adapter	*	34	7942-9	3-Way Connector, Male	*
6	5996-4	16-14 GA Bullet Conn., Male	*	35	8944	3-Way Locking Connector, Male	*
7	5996-5	16-14 GA Bullet Conn., Female	*	36	8944-1	3-Way Locking Connector, Female	*
8	5940-4	16-14 GA Spg. Loaded Term., Female	*	37	7942-11	4-Way Connector, Male	*
9	5940-7	Brass Wire Clip, Female	*	38	7942-12	4-Way Connector, Female	*
10	5996	1/4 x 16-14 GA QKS Term., Female	*	39	7942-5	5-Way Connector, Male	*
11	5996-2	3/16 x 22-18 GA QKS Term., Female	*	40	5940-2	5-Way Connector, Male	*
12	7996	3/16 x 16-14 GA QKS Term., Female	*	41	8942-1	5-Way Connector, Female	*
13	5940-5	16-14 GA Spg. Loaded Term., Male	*	42	7942-6	6-Way Connector, Male	*
14	5996-0	1/4 x 22-18 GA QKS Term., Male	*	43	7942-7	6-Way Connector, Male	*
15	5996-18	16-14 GA Ring Term. (#8) Nylon Insulated	*	44	7942-8	8-Way Connector, Male	*
16	7996-1	1/4 x 16-14 GA QKS Term., Male	*	45	8942-2	8-Way Connector, Female	*
17	5996-8	6 GA Ring Lug (5/16)	*	46	8942-3	5-Way Connector, Male	*
18	5996-9	22-18 GA Ring Term., #10	*	47	5940-9	3-Way Connector (M)	*
19	5996-10	16-14 GA Ring Term. (5/16)	*	48	7942-15	6-Way Connector (Female)	*
20	5996-12	12-10 GA Ring Term. (5/16)	*	49	7940-3	Packard Plug (Male)	*
21	5996-13	16-14 GA Ring Term., # 10	*	50	7940-4	Packard Plug (Female)	*
22	5996-15	12-10 GA Ring Term. (1/2)	*	* Service Part Only			
23	5996-16	6 GA Ring Terminal (1/4)	*	<b>NOTE:</b> Not all Electrical Connectors are used with all assemblies.			
24	5996-17	16-14 GA Ring Term. (1/4)	*	<b>NOTE:</b> Refer to <b>ELECTRICAL ASSEMBLIES</b> , Pages 32-39 for locations of Wiring Harness, Electrical Components and of all Electrical Wiring Service Parts.			
25	5996-20	12-10 GA Ring Term. (1/4)	*				
26	5996-21	12-10 GA Ring Term., #10	*				
27	7942-4	Single Connector, Male	*				
28	8942	2-Way Connector, Male	*				

# ELECTRICAL CONNECTORS

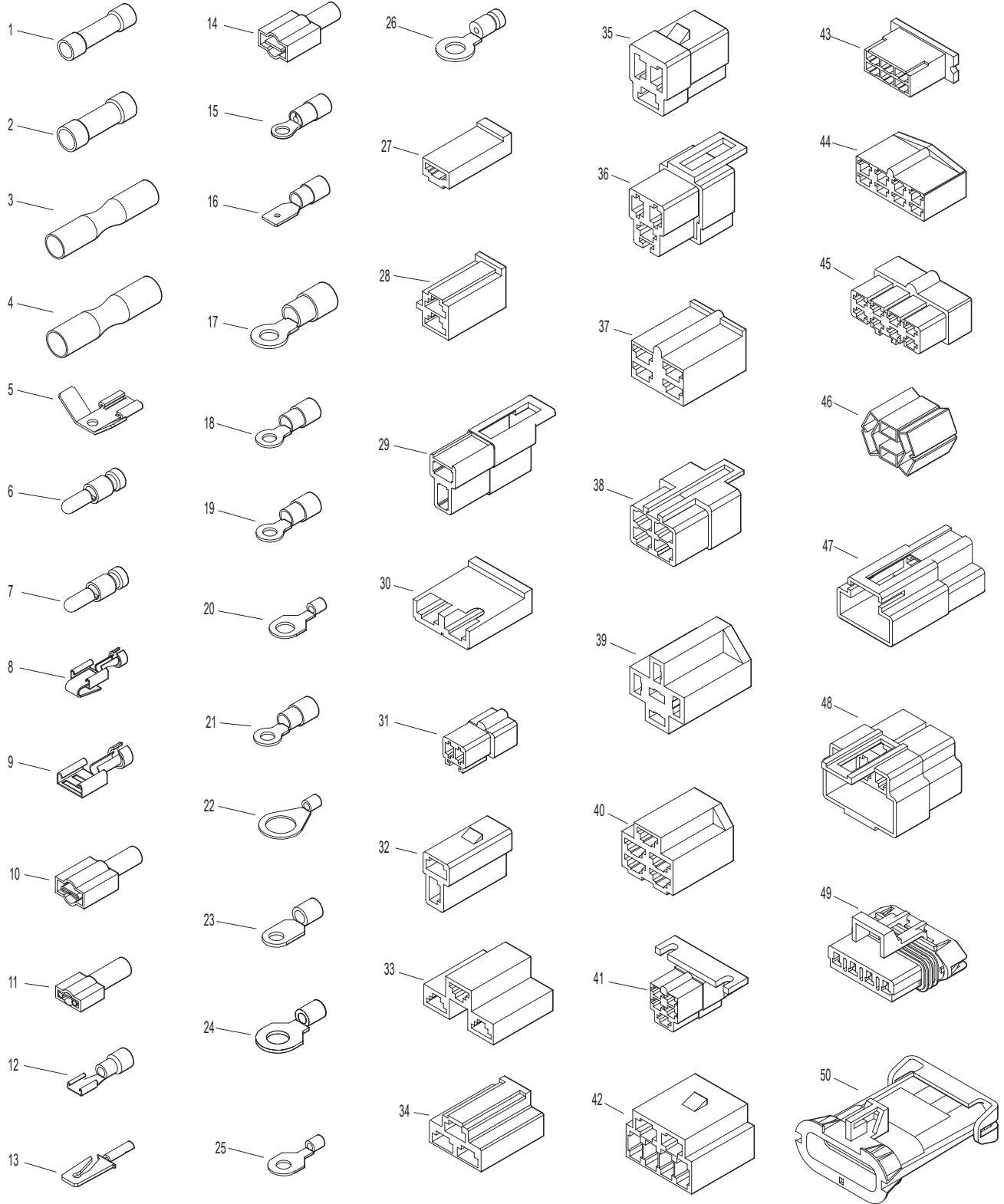

# ARMREST KIT / TOUCH-UP PAINT

ITEM NO.	PART NO.	DESCRIPTION	NO. REQ'D
----------	----------	-------------	-----------

**Kit 5885 Armrest Option / Kit**

Includes Items # 1-5, fasteners listed and instructions. May be ordered as a dealer-installed option. Contact your Walker dealer.

1	5886-1	Armrest, RH	1
2	5886-3	Cover Plate, RH	1
3	5887	Mounting Bracket	1
4	5886-4	Cover Plate, LH	1
5	5886-2	Armrest, LH	1
	5888	Armrest Hardware Kit (Includes Items # F305, F306, F307 & F308)	*

ITEM NO.	PART NO.	DESCRIPTION	NO. REQ'D
----------	----------	-------------	-----------

**Touch-Up Paint**

6	5866	Touch-Up Paint, Yellow (12 oz. Aerosol)	
7	5867	Touch-Up Paint, Grey (12 oz. Aerosol)	

**Fasteners**

	F305	1/4-20 x 3/8 SH Cap Screw	2
	F306	3/8-16 x 3/4 Hex Bolt	4
	F307	#10 x 5/8 PPHST Screw	2
	F308	1-1/4 x 1-5/8 Wave Spring Washer	2

\* Service Part Only

# ARMREST KIT / TOUCH-UP PAINT

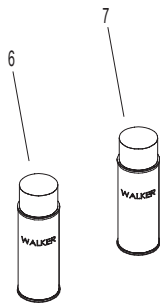
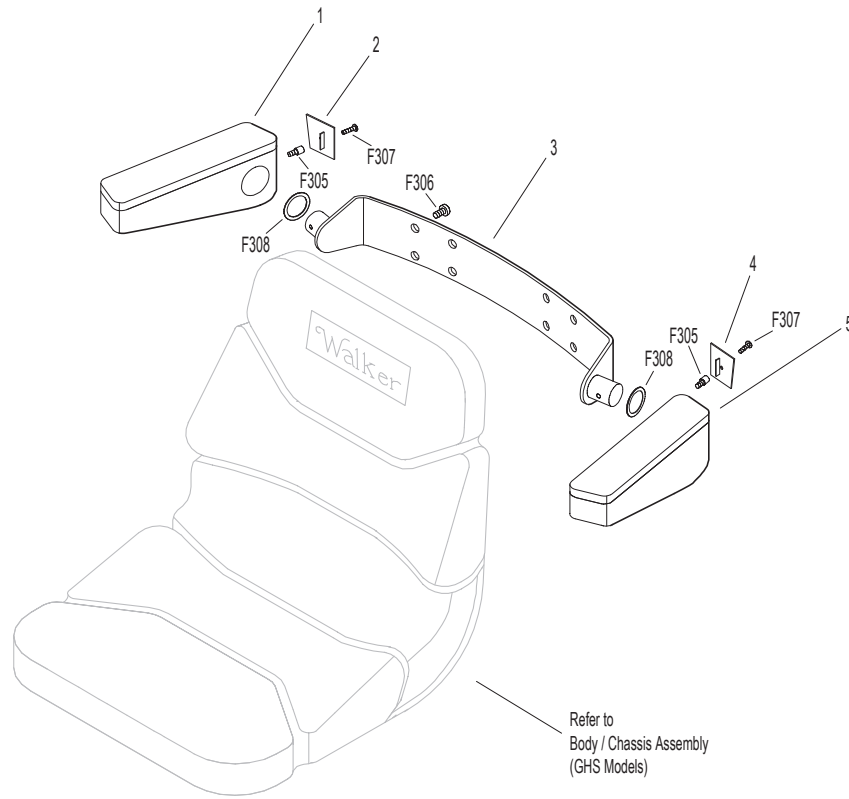

## COMFORT SEAT / ARMREST KIT

ITEM NO.	PART NO.	DESCRIPTION	NO. REQ'D
----------	----------	-------------	-----------

**Kit 6103-5 Comfort Seat Option / Kit**

Includes Items # 1, 6, fasteners listed (except as indicated; refer to **NOTE**) and instructions. May be ordered as a factory-installed option or as a kit for dealer installation. Contact your Walker dealer.

1	6103-5	Comfort Seat Kit	1
2	7203	Seat Spring Plate	1
3	7223	Compression Spring (1/2 x 1)	2
4	7846	Rubber Washer (3/8 x 1-1/4 x 1/8)	2
5	7204	Shoulder Bolt, Seat Mount	2
6	7203-6	Riser Plate	*
7	7845	Rubber Bumper (1.375 OD x .63)	2
8	7440-5	Shock Mount (1-1/4 x 2)	2

ITEM NO.	PART NO.	DESCRIPTION	NO. REQ'D
----------	----------	-------------	-----------

**Kit 6103-17 Armrest Option / Kit**

Includes Items # 9, 10 and instructions. Item # 9 is the **Right** side armrest only. Item # 10 is the **Left** side armrest only. Sold only as a complete set and may be ordered together as a kit for dealer installation. Contact your Walker dealer.

9	6103-42	Armrest, RH / CS	1
10	6103-41	Armrest, LH / CS	1

**Fasteners**

F009	5/16 - 18 Whiz Locknut	2
F026	10-24 x 1/2 PPHMS	2
F227	3/8-1-1/4 x 1/8 Plastic Washer	2

\* Only one Riser Plate is included with kit. One is reused from Seat Switch. Refer to **ELECTRICAL ASSEMBLIES (BODY COMPONENTS)**, Page 34.

**NOTE:** Reuse Items # 3-8, F009 and F227 from Seat Assembly. Refer to **BODY / CHASSIS ASSEMBLY (GHS MODELS)**, Page 4.

# COMFORT SEAT / ARMREST KIT

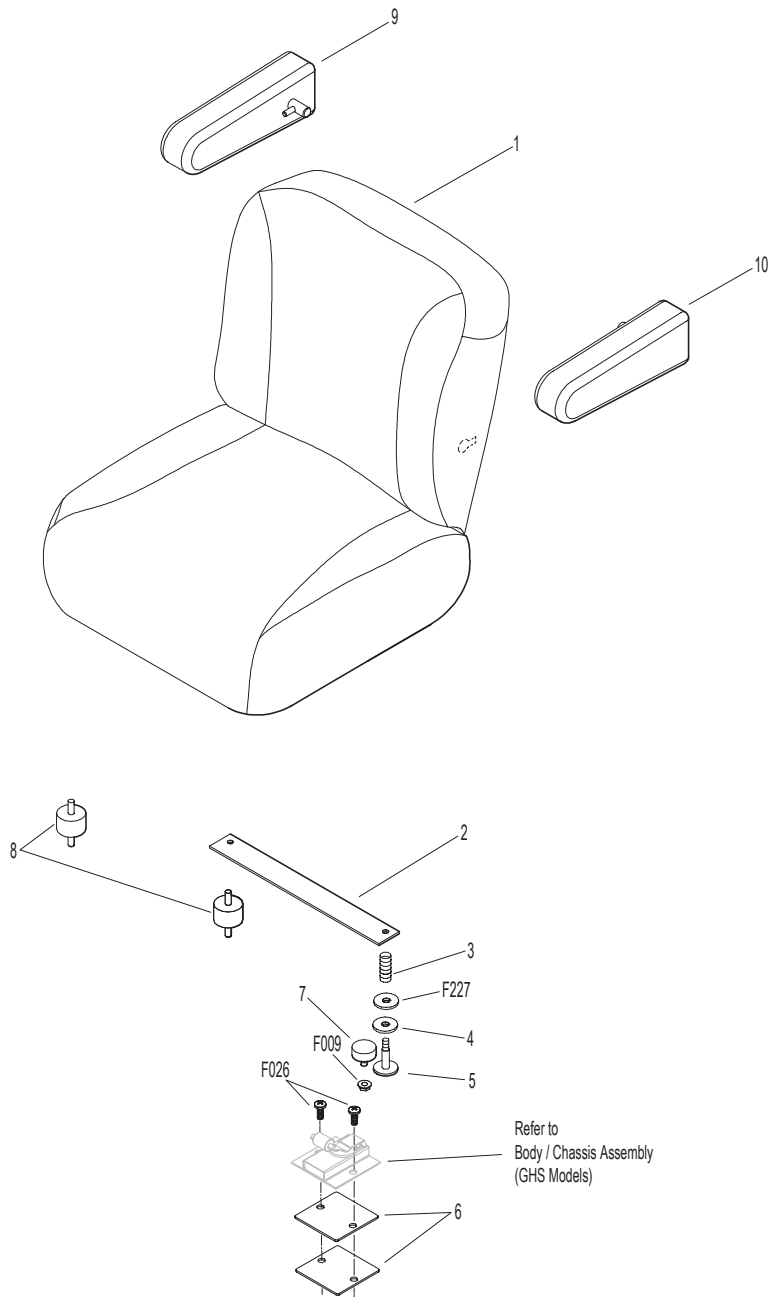

# SUSPENSION SEAT KIT

ITEM NO.	PART NO.	DESCRIPTION	NO. REQ'D
----------	----------	-------------	-----------

**Kit 6103-9 Armrest Kit**

Includes Items # 1-6 and instructions. May be ordered as a kit for dealer installation. Contact your Walker dealer.

1	6103-92	Armrest, SS / RH	1
2	NS	5/8 Nut Cover	4
3	NS	7/16-20 x 13/4 HHCS	4
4	NS	3/8 SAE Washer	4
5	NS	Bushing, 3/4 x 3/4	4
6	6103-91	Armrest, SS / LH	1

**Kit 6103-25 Suspension Seat Option / Kit**

Includes Items # 7-9, 11-13, 18, 21, fasteners listed (except as indicated; refer to **NOTE**) and instructions. May be ordered as a factory-installed option or as a kit for dealer installation. Contact your Walker dealer.

7	6103-11	Suspension Seat	1
8	5941-5	Safety Switch (NO)	*
9	6103-33	Seat Mount Plate, SS / LH	1
10	7223	Compression Spring (1/2 x 1)	2
11	5975-3	Cable Tie (50# x 7")	2
12	5975-1	Cable Tie (18# x 3-3/4")	1
13	6103-23	Wire Harness, SS	1
14	7846	Rubber Washer 3/8 x 1-1/4 x 1/8	2
15	7204	Shoulder Bolt, Seat Mount	2
16	5453-20	Steering Lever Handle +1" Adj. / SS	2
17	5977-6	Grommet (1 x 1-1/4)	2
18	5841	Retainer Washer	2
19	7845	Rubber Bumper (1.375 x 0.63)	2
20	7440-5	Shock Mount (1-1/4 x 2)	2
21	6103-34	Seat Mount Plate, SS / RH	1

ITEM NO.	PART NO.	DESCRIPTION	NO. REQ'D
----------	----------	-------------	-----------

**Fasteners**

F002	10-24 Keps Nut	4
F009	5/16-18 Whiz Locknut	6
F026	10-24 x 1/2 PPHMS	4
F168	5/16 Split Lock Washer	4
F227	3/8 x 1-1/4 x 1/8 Washer (Plastic)	2
F357	M8 x 16 Hex Bolt	2
F358	M8 x 25 Hex Bolt	2

\* Only one Safety Switch is included with kit. One is reused from Electrical Assembly. Refer to **ELECTRICAL ASSEMBLIES (BODY COMPONENTS)**, Page 34.

**NOTE:** Reuse Items # 4, 8-10, 12, two (2) each of Items # F002, F009 and F026, and Item # F227 from Seat Assembly. Refer to **BODY / CHASSIS ASSEMBLY (GHS MODELS)**, Page 4.



# SUSPENSION SEAT KIT

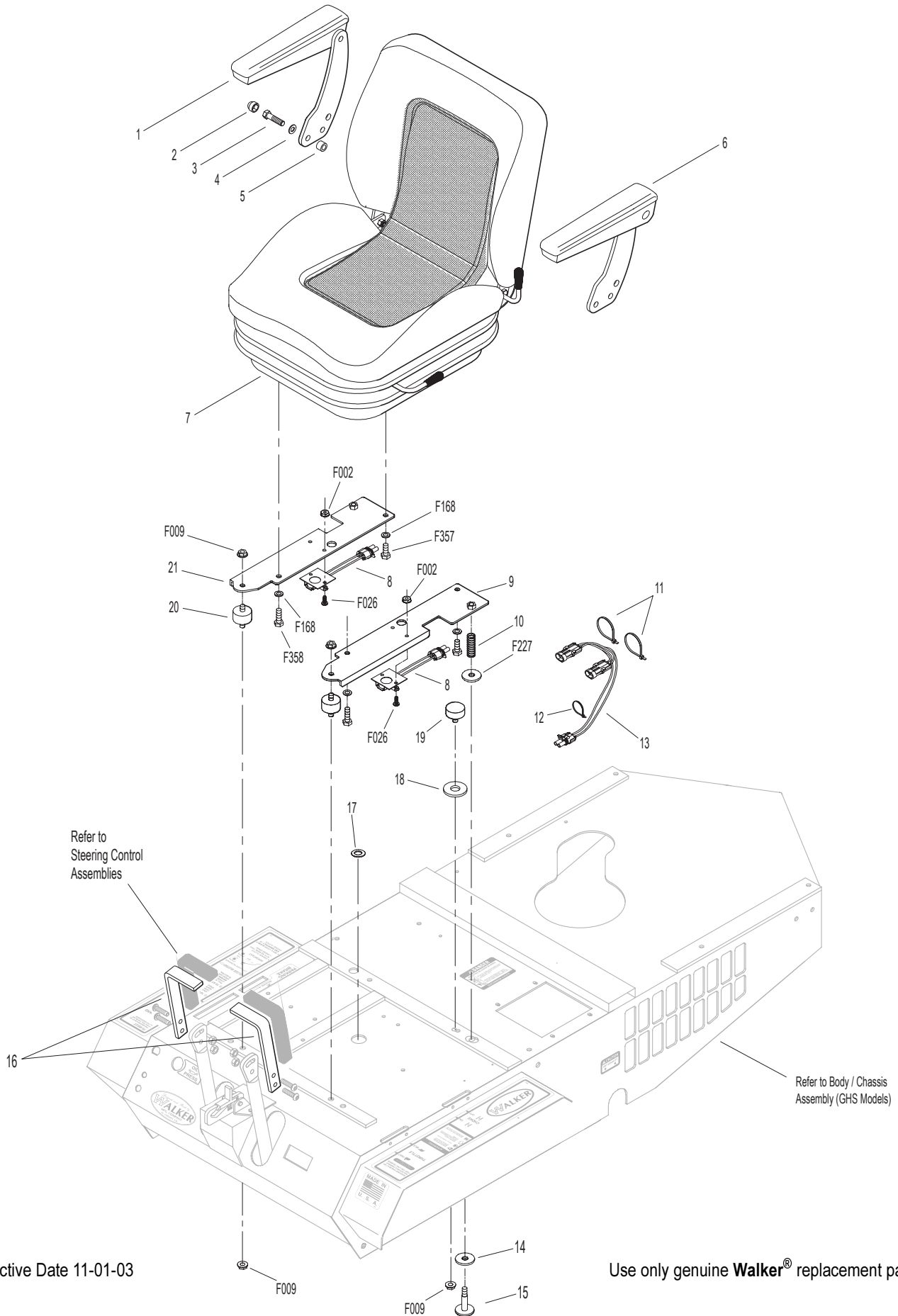

Refer to  
Steering Control  
Assemblies

Refer to Body / Chassis  
Assembly (GHS Models)

Effective Date 11-01-03

Use only genuine Walker® replacement parts.

# LIGHT KIT

ITEM NO.	PART NO.	DESCRIPTION	NO. REQ'D	ITEM NO.	PART NO.	DESCRIPTION	NO. REQ'D
<b>Kit 5989 Light Option / Kit</b> Includes Items # 1-10, fasteners listed and instructions. May be ordered as a kit for dealer installation. Contact your Walker dealer.				<b>Fasteners</b>			
1	5989-2	Light Assembly (Includes Sealed Beam Lamp)	2	F009		5/16-18 Whiz Locknut	2
	5989-6	Sealed Beam Lamp	*	F091		5/16-18 x 5/8 Hex Bolt	2
2	7834-1	Half U-Wire Clip	4	F134		AN960816L Washer	2
3	5977-1	Grommet (1/8 x 3/8)	2	* Service Part Only			
4	5975-5	Wire Clip, Self-Mount	3	<b>NOTE:</b> Upon installation of kit, Item # 3 replaces P/N 5989-4 (Dome Plug, 3/8), Item # 5 replaces P/N 5989-5 (Dome Plug, 7/16), and Item # F091 replaces P/N 5989-3 (Dome Plug, 5/16). Dome Plugs are not shown here. Refer to <b>BODY / CHASSIS ASSEMBLY (GHS MODELS)</b> , Page 4.			
5	5975-1	Cable Tie (18# x 3-3/4")	1	<b>NOTE:</b> Refer to <b>ELECTRICAL CONNECTORS</b> , Page 40 for identification of all Electrical Wiring Service Parts.			
6	6940-10	Jumper Wire	1				
7	5995	Toggle Switch (Off-On)	1				
8	5995-2	Switch Boot	1				
9	7995-3	Power Lead Wire Assembly (Includes Item # 3 & 5)	1				
10	7992	Mount Bracket, Lights	1				

# LIGHT KIT

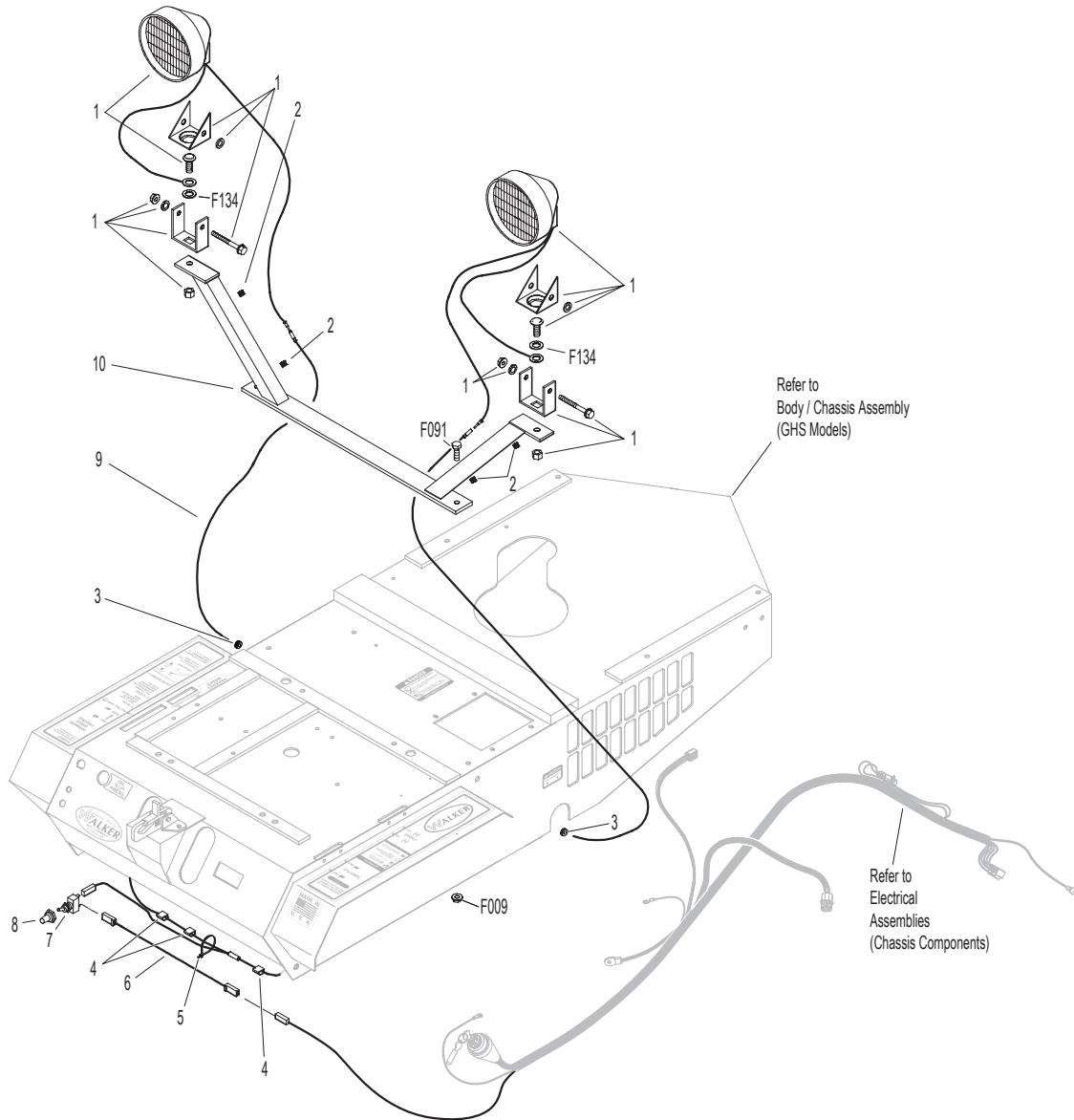

# BLOWER LOCKOUT KIT / CASE-HARDENED BLOWER

ITEM NO.	PART NO.	DESCRIPTION	NO. REQ'D
----------	----------	-------------	-----------

**Kit 6541 Blower Lockout Kit**

Includes Items # 1-7, fasteners listed and instructions. May be ordered as a kit for dealer installation. Contact your Walker dealer.

1	7854	Plastic Tip, Red	*
2	6541-2	Blower Lockout Rod (Includes Item #1)	1
3	6541-1	Blower Lockout Latch	1
4	5280	Clevis (1/4)	1
5	5281-5	Clevis Pin (1/4 x 0.80)	1
6	6541-3	Blower Lockout Pivot Arm	1
7	6541-4	Blower Lockout Belt Guide	1

ITEM NO.	PART NO.	DESCRIPTION	NO. REQ'D
----------	----------	-------------	-----------

**Kit 6542-15 Case Hardened Blower Option / Kit**

Includes Items # 8-12, fasteners listed and instructions. May be ordered as a kit for dealer installation. Contact your Walker dealer.

8	5268	Bearing (3/4) Includes Locking Collar	2
9	6543-15	Blower Housing (10") HT	1
10	6545-15	Blower Wheel (10") HT	1
11	6525-2	Faceplate (10" Blower)	1
12	6526	Intake Tube (6-1/2 x 2-1/2)	1

**Fasteners**

F003	1/4-28 Hex Nut	1
F004	1/4-20 Keps Nut	7
F032	1/4-20 x 3/4 Hex Bolt	1
F074	1/4-20 x 3/8 Set Screw	2
F091	5/16-18 x 5/8 Hex Bolt	1
F186	5/64 x 1/2 Cotter Pin	1
F325	1/4-20 x 3 Hex Bolt	1

\* Service Part Only

# BLOWER LOCKOUT KIT / CASE-HARDENED BLOWER

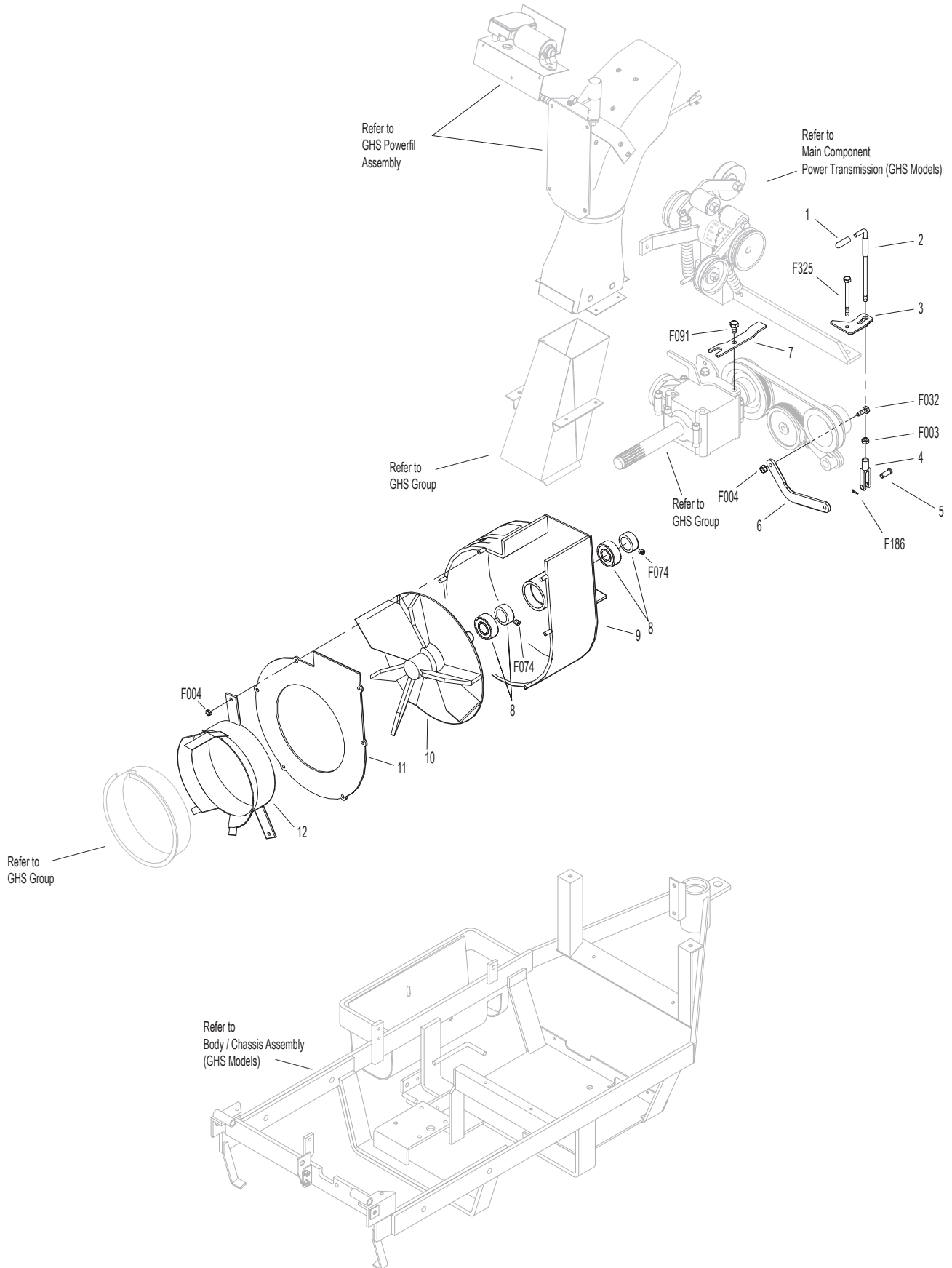

## NO CATCH DEFLECTOR KIT (6.7 BUSHEL)

ITEM NO.	PART NO.	DESCRIPTION	NO. REQ'D	ITEM NO.	PART NO.	DESCRIPTION	NO. REQ'D
<b>Kit</b>	<b>5500</b>	<b>No Catch Deflector Option / Kit (6.7 Bushel)</b>		<b>Fasteners</b>			
		Includes Items # 1-10, fasteners listed and instructions. May be ordered as a kit for dealer installation. Contact your Walker dealer.			F002	10-24 Keps Nut	4
1	8500-5	Side Bracket	2		F030	1/4-20 x 1/2 PPH Bolt	1
2	8787-2	Knob (1/4-20) Threaded Insert	1		F128	10-24 x 3/8 PTHMS	4
3	5500	No Catch Deflector Kit, 6.7 (Includes Items # 4 & F340)	1		F146	1/4-20 Jam Nut	1
4	5726-10	Hinge (2 x 8)	2		F333	1/4-20 x 3/4 PTHMS	1
5	8500-8	Decal, No Catch Deflector	1		F340	Rivet, Aluminum	20
6	8500-6	Spacer Lug	1	<b>NOTE:</b> Refer to <b>ELECTRICAL CONNECTORS</b> , Page 40 for identification of all Electrical Wiring Service Parts.			
7	5500-8	Wire Assembly, No Catch Deflector, 6.7	1				
8	5995	Toggle Switch (Off - On)	1				
9	8500-9	Decal, Off - On	1				
10	5995-2	Switch Boot	1				

# NO CATCH DEFLECTOR KIT (6.7 BUSHEL)

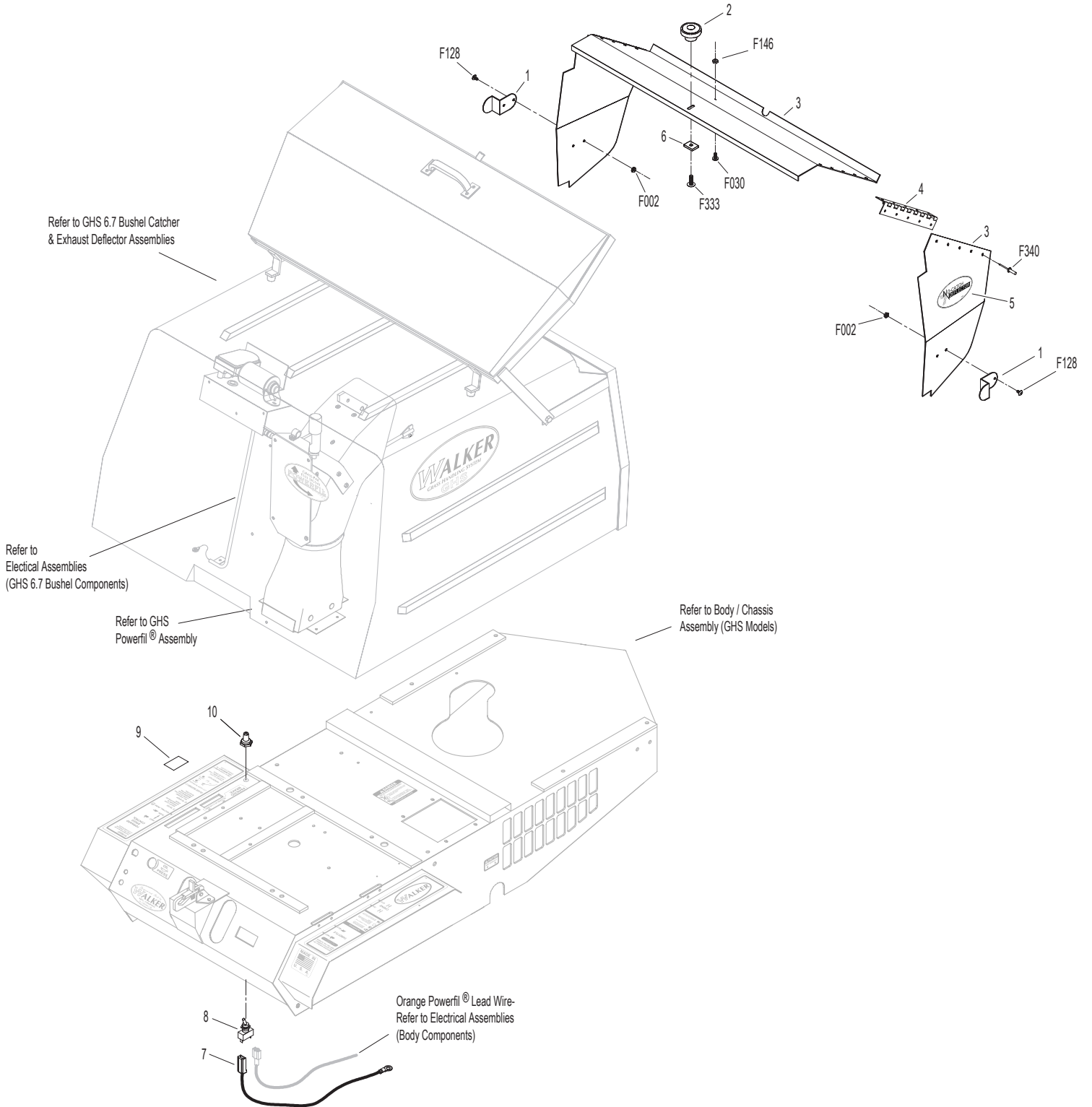

## NO CATCH DEFLECTOR KIT (9.5 BUSHEL)

ITEM NO.	PART NO.	DESCRIPTION	NO. REQ'D	ITEM NO.	PART NO.	DESCRIPTION	NO. REQ'D
<b>Kit</b>	<b>8500</b>	<b>No Catch Deflector Option / Kit (9.5 Bushel)</b>		<b>Fasteners</b>			
		Includes Items # 1-6, fasteners listed and instructions. May be ordered as a kit for dealer installation. Contact your Walker dealer.			F002	10-24 Keps Nut	4
1	8500-5	Side Bracket	2		F030	1/4-20 x 1/2 PPH Bolt	1
2	8500	No-Catch Deflector Kit, 9.5 (Includes Items # 4 & F340)	1		F128	10-24 x 3/8 PTHMS	4
3	8787-2	Knob (1/4-20) Threaded Insert	1		F146	1/4-20 Jam Nut	1
4	7726-10	Hinge (2 x 11)	2		F333	1/4-20 x 3/4 PTHMS	1
5	8500-8	Decal, No Catch Deflector	1		F340	Rivet, Aluminum	24
6	8500-6	Spacer Lug	1				



# NO CATCH DEFLECTOR KIT (9.5 BUSHEL)

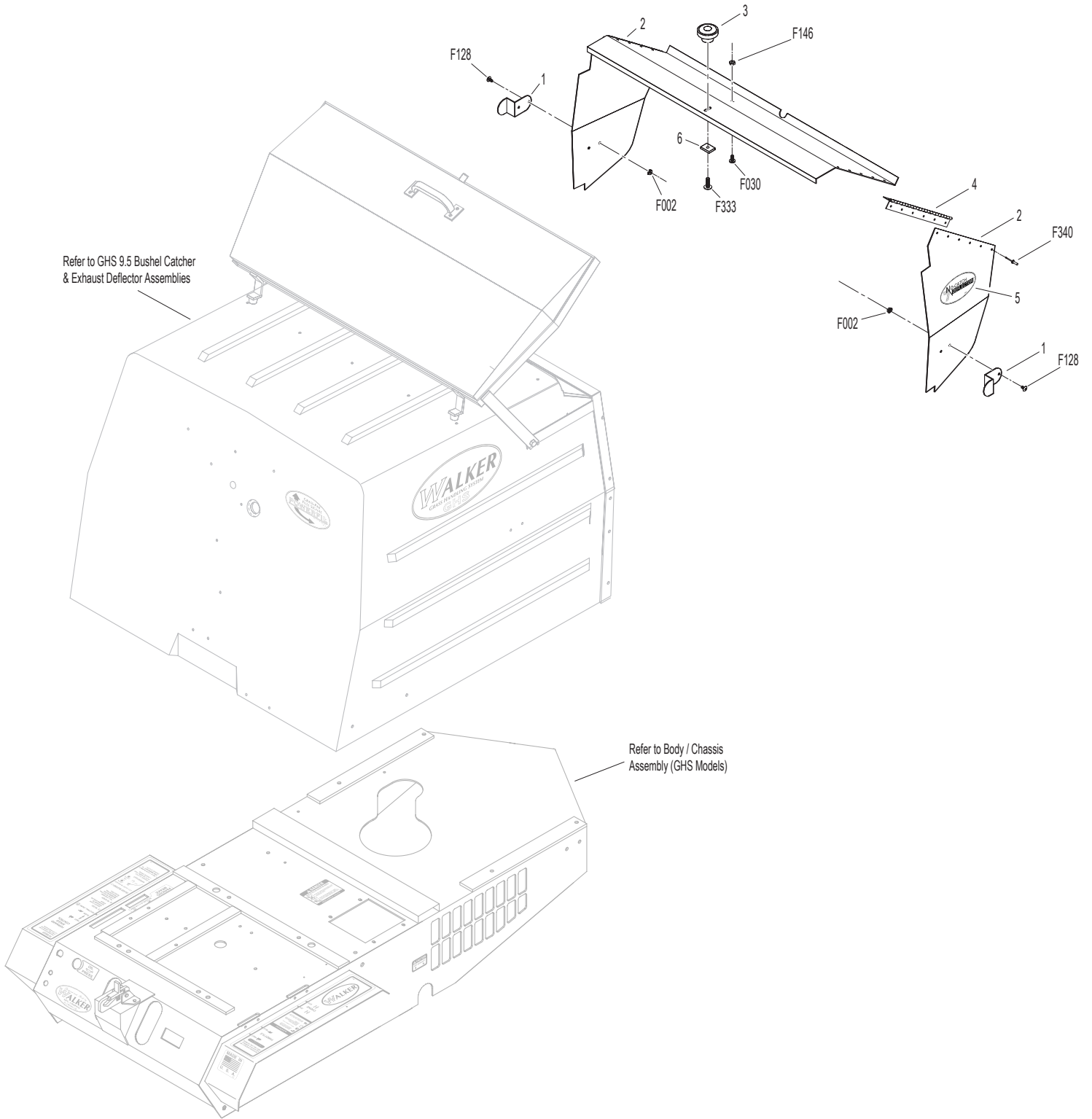

# ALL-TERRAIN TIRE KIT & TIRE CHAIN SETS

ITEM NO.	PART NO.	DESCRIPTION	NO. REQ'D
----------	----------	-------------	-----------

**Kit 8072 All-Terrain Tire Option / Kit**  
Includes Items # 1-3 and instructions. May be ordered as a kit for dealer installation. Contact your Walker dealer.

1	8070	All-Terrain Wheel & Tire, RH (18 x 11.00-10)	1
	8070-1	AT Tire Only (18 x 11.00-10)	*
	8070-2	AT Wheel Only (10 x 8.5)	*
2	8070-31	Wheel Spacer Plate (1/2)	2
3	8071	All-Terrain Wheel & Tire, LH (18 x 11.00-10)	1

ITEM NO.	PART NO.	DESCRIPTION	NO. REQ'D
----------	----------	-------------	-----------

**Optional Tire Chain Sets**  
Includes Items # 2 and 4. Tire Chain Sets are not for use on All-Terrain Tires. Use only with tires listed at Item # 4. Refer also to **BODY / CHASSIS ASSEMBLY (GHS MODELS)**, Page 4.

4	5675-2	Tire Chain Set (18 x 8.50-8) (Includes Item # 2) (For use with Wide Wheel & Tire Assy)	1
	5675	Tire Chain Set (18 x 6.50-8) (Includes Item # 2) (For use with Optional Narrow Drive Tires)	1

### Fasteners

F157	1/2-20 x 1-1/4 Wheel Lug Bolt	8
------	-------------------------------	---

\* Service Part Only

**NOTE:** Reuse Item # F157 from Wheel & Tire Assembly. Refer to **BODY / CHASSIS ASSEMBLY (GHS MODELS)**, Page 4.

# ALL-TERRAIN TIRE KIT & TIRE CHAIN SETS

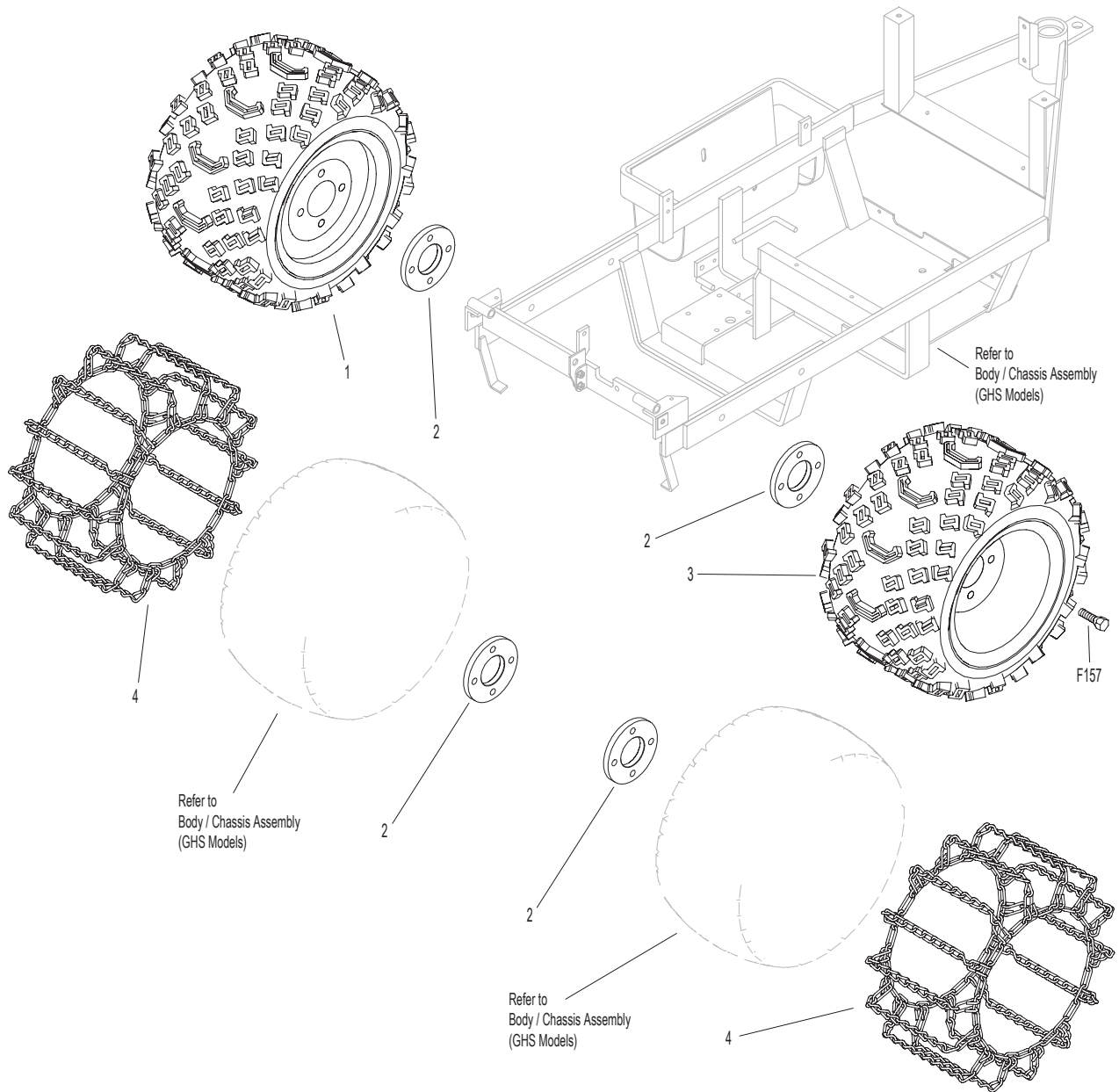

# LUBRICATION POINTS

ITEM NO.	LOCATION	LUBRICATION TYPE	NO. PLACES	ITEM NO.	LOCATION	LUBRICATION TYPE	NO. PLACES
<b>Lubrication Points</b>				27	Brake Actuator Pivot	Grease	1
1	Deck Caster Wheel Fork Pivot	Grease	2	28	Anti-Scuff Roller Wheel	Oil	2
2	Deck Caster Wheel Bearing	Grease	2	29	Catcher Hinge Point	Oil	2
3	Tee Gearbox, Deck	Oil*	1	30	Choke Control Cable Ends	Oil	2
4	Blade Drive Gearbox	Oil*	2	31	Throttle Control Cable Ends	Oil	2
5	PTO Shaft Guard Hinge	Oil	1	32	Engine Oil	Oil***	1
6	Universal Joint Shaft Assembly	Grease**	1	33	Belt Tightener Pivot, Blower Drive (GHS Model Only)	Grease	1
7	Pivot Assembly, Tilt-Up Deck	Grease	4	34	Belt Tightener Pivot, Ground Drive	Grease	1
8	Deck Support Arm Socket	Grease	2	35	PTO Gearbox Dipstick	Oil***	1
9	Body Hinge Point	Oil	2	36	Hydrostatic Drive	Oil***	2
10	FSC Actuator Rod Pivot Pins	Oil	2	37	Choke Control Pivot	Oil	1
11	FSC Lever Pivot	Grease	1	38	Throttle Control Pivot	Oil	1
12	FSC Lever Fork (Grease Slide Area)	Grease	1	39	Discharge Chute Hinge	Oil	1
13	(FSC) Friction Body Pivot	Grease	1	40	Tilt-Up Latch Assembly	Oil	1
14	Steering Lever Pivot	Grease	4	41	Steering Lever Support	Oil	1
15	Deck Roller Wheel	Oil	2				
16	Deck Support Arm Pivot	Grease	2	* Gearboxes are permanently lubricated and sealed requiring no scheduled lubrication. Oil level should be checked only when an oil leak is noted.			
17	Deck-to-PTO Coupling (Grease Slide Area)	Grease	1	** Grease every eight (8) hours.			
18	Universal Joint Tube Assembly	Grease**	1	*** See Owner's Manual for procedure for checking and changing oil in Engine Crankcase, Hydrostatic Transmissions, and Gear Axles.			
19	Universal Joint Quick Connect Spline (Grease Slide Area)	Grease	1	<b>NOTE:</b> See Model MC <b>Owner's Manual</b> (P/N 6000-8) for proper lubrication intervals.			
20	Parking Brake Lever	Grease	1	<b>NOTE:</b> DGHS42 Tilt-Up Deck is shown for reference. For other Deck Lubrication Points, refer to <b>Deck and Carrier Frame Illustrated Parts Manual</b> .			
21	Gear Axle	Oil***	2				
22	Belt Tightener Pivot, Jackshaft Drive	Grease	1				
23	Clutch Actuator Push Rod	Grease	2				
24	PTO Clutch Lever Pivot	Grease	1				
25	Belt Tightener Pivot, PTO Clutch	Grease	1				
26	Brake Actuator Rod and Brake Band Pivot Pins (Clevis)	Oil	3				

# LUBRICATION POINTS

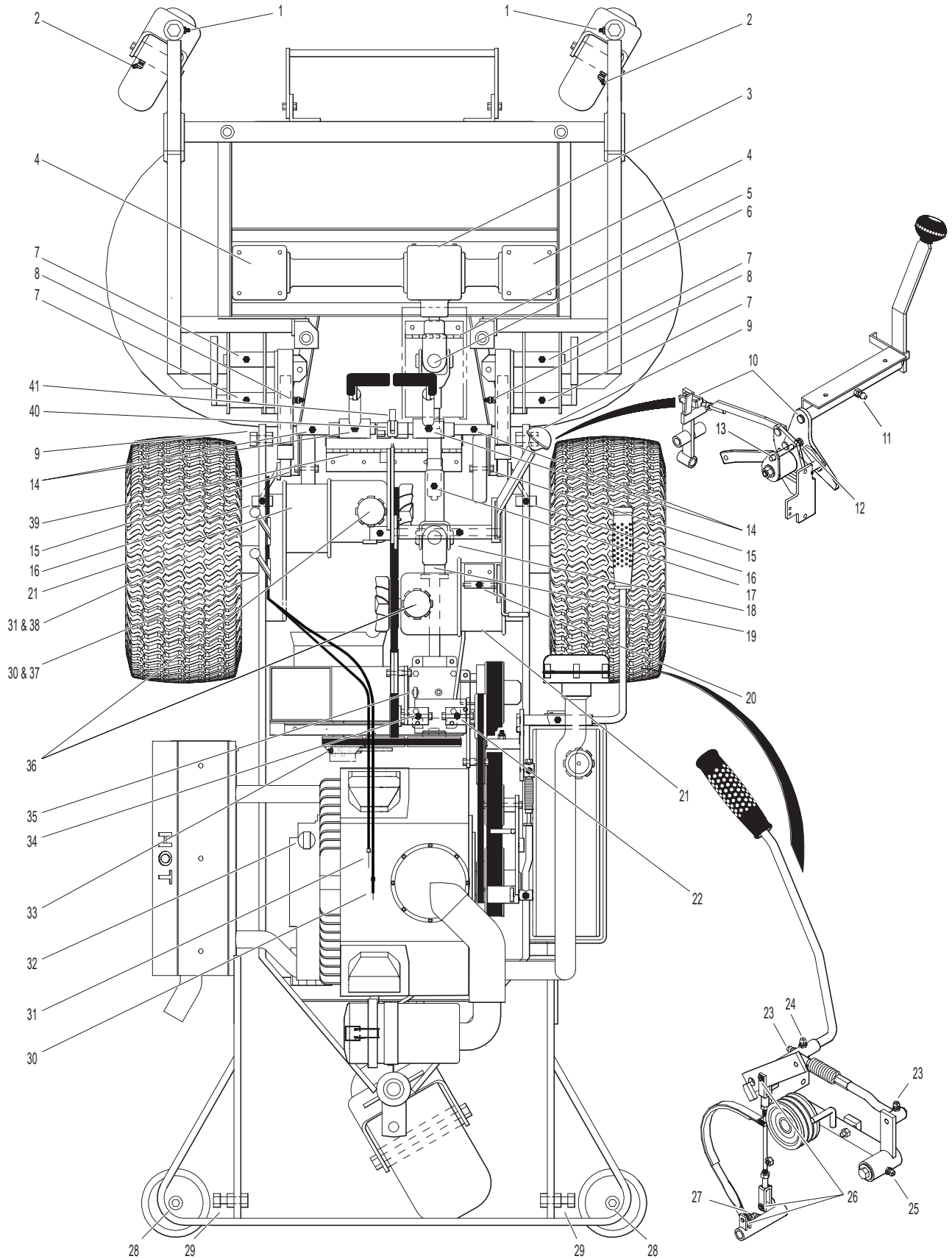

Effective Date 11-01-03

Use only genuine **Walker**® replacement parts.

# WIRING SCHEMATIC

## WALKER MODEL MC Beginning S/N 2001-49399

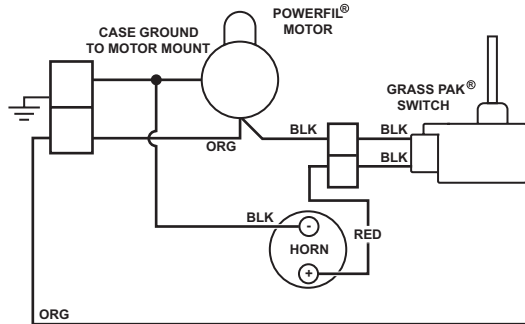

IGNITION SWITCH CIRCUITS	
OFF	G + M
START	B + A / S1 + S2
RUN	B + A

S1 = START CIRCUIT  
S2 = START/ACCESSORY CIRCUIT  
M = MAGNETO GROUND CIRCUIT  
B = BATTERY CIRCUIT  
A = ACCESSORY CIRCUIT  
G = GROUND CIRCUIT

RELAY - A IGNITION RELAY	
OFF	30 + 87A
START	30 + 87A
PTO ON	OPEN

RELAY - B START RELAY	
OFF	OPEN
START	OPEN
PTO ON	30 + 87

RELAY - C DELAY RELAY	
OFF	30 + 87A
START	OPEN
RUN	OPEN

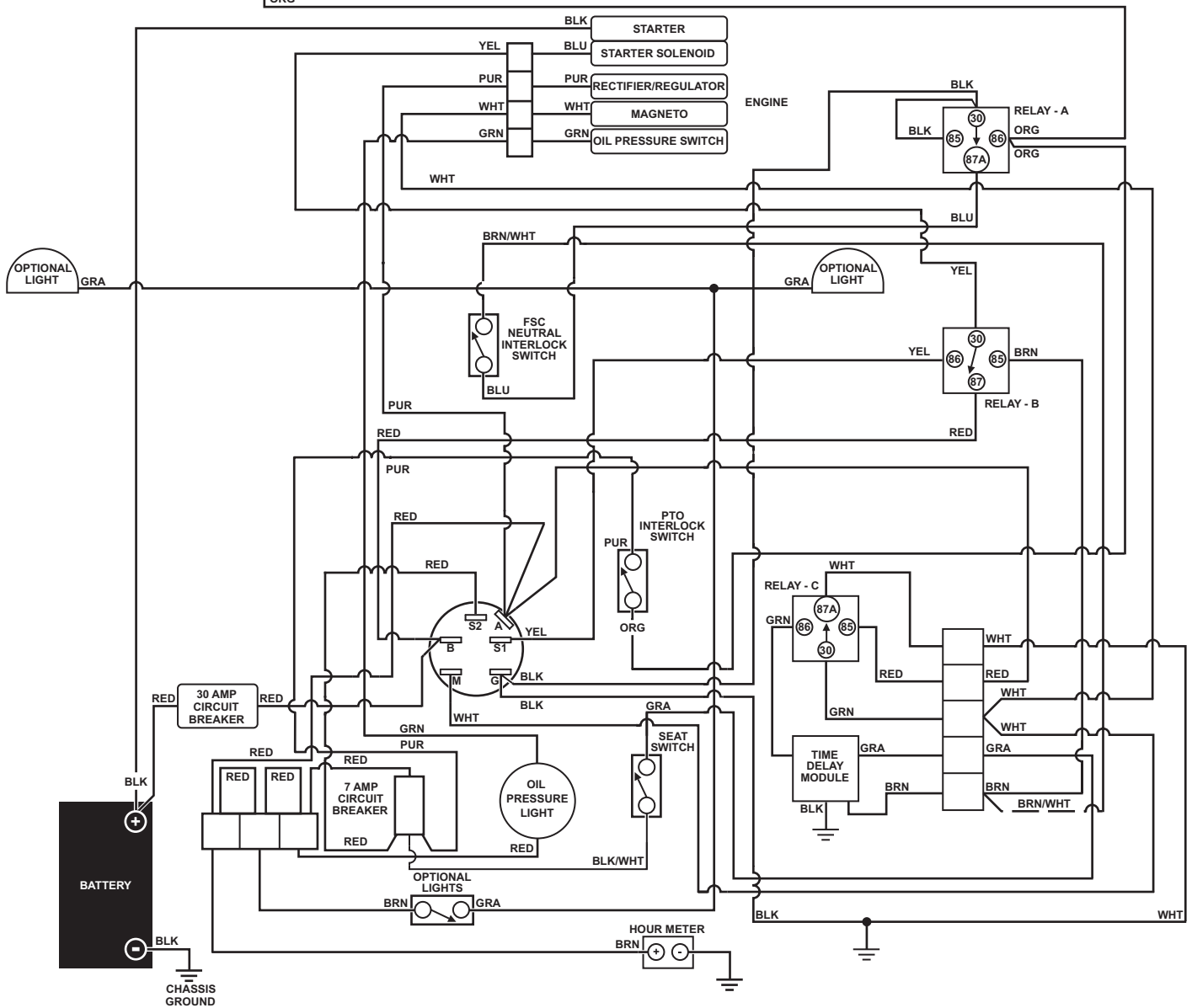

# **LIMITED WARRANTY FOR WALKER COMMERCIAL RIDER MOWER**

## **1. WHAT THIS WARRANTY COVERS, AND FOR HOW LONG:**

Walker Manufacturing company will, at its option, repair or replace, without charge, any part covered by this warranty which is found to be defective in material and/or workmanship within one (1) year\* after date of sale to the original retail purchaser unless the product is used for rental purposes, in which case this warranty is limited to ninety (90) days. At Walker's request, customer will make the defective part available for inspection by Walker and/or return the defective part to Walker, transportation charges prepaid. All parts and components of the Walker Mower are covered by this warranty **except** the following components which are warranted separately by their respective manufacturers:

Kohler Engine  
Kubota Engine  
Kawasaki Engine  
Eaton Hydraulic Transmission  
Peerless Gearboxes  
Battery  
Tires

The available warranties covering these items are furnished with each mower. Walker does not assume any warranty obligation, liability or modification for these items, which are covered exclusively by the stated warranty of the respective manufacturers noted above.

\* An extended three (3) year warranty is offered on the Walker P/N 6200-9 Gear Axle Assembly.

## **2. WHAT THIS WARRANTY DOES NOT COVER:**

- A. This warranty does not cover defects caused by depreciation or damage caused by normal wear, accidents, improper maintenance, improper use or abuse of the product, alterations, or failure to follow the instructions contained in the Owner's Manual for operation and maintenance.
- B. The customer shall pay any charges for making service calls and/or for transporting the mower to and from the place where the inspection and/or warranty work is performed.

## **3. HOW TO OBTAIN SERVICE UNDER THIS WARRANTY:**

Warranty service can be arranged by contacting the dealer where you purchased the mower or by contacting Walker Manufacturing Company, 5925 East Harmony Road, Ft. Collins, CO 80528. Proof of the date of purchase may be required to verify warranty coverage.

## **4. WARRANTY LIMITATION:**

- A. **THERE IS NO OTHER EXPRESS WARRANTY. ANY WARRANTY THAT MAY BE IMPLIED FROM THIS PURCHASE INCLUDING MERCHANTABILITY AND FITNESS FOR A PARTICULAR PURPOSE IS HEREBY LIMITED TO THE DURATION OF THIS WARRANTY AND TO THE EXTENT PERMITTED BY LAW ANY AND ALL IMPLIED WARRANTIES ARE EXCLUDED.** Some states do not allow limitations on how long an implied warranty lasts, so the above limitations may not apply to you.
- B. **WALKER WILL NOT BE LIABLE FOR ANY INCIDENTAL, CONSEQUENTIAL, OR SPECIAL DAMAGES AND/OR EXPENSES IN CONNECTION WITH THE PURCHASE OR USE OF THE MOWER.** Some states do not allow the exclusion or limitation of incidental or consequential damages, so the above limitation(s) or exclusion(s) may not apply to you.
- C. Only the warranty expressed in this limited warranty shall apply and no dealer, distributor, or individual is authorized to amend, modify, or extend this warranty in any way. Accordingly, additional statements such as dealer advertising or presentations, whether oral or written, do not constitute warranties by Walker, and should not be relied upon.
- D. This warranty gives you specific legal rights, and you may also have other rights which vary from state to state.

# WALKER MOWERS™

WALKER MFG. CO. • 5925 E. HARMONY ROAD, FORT COLLINS, CO 80528 • (970) 221-5614  
FORM NO. 12013      PRINTED IN USA      [www.walkermowers.com](http://www.walkermowers.com)      ©2003 WALKER MFG. CO