

Walker Rider Lawnmowers

ILLUSTRATED PARTS MANUAL

Model MDD (20.9 HP Diesel)
(Covers 2003 Production)

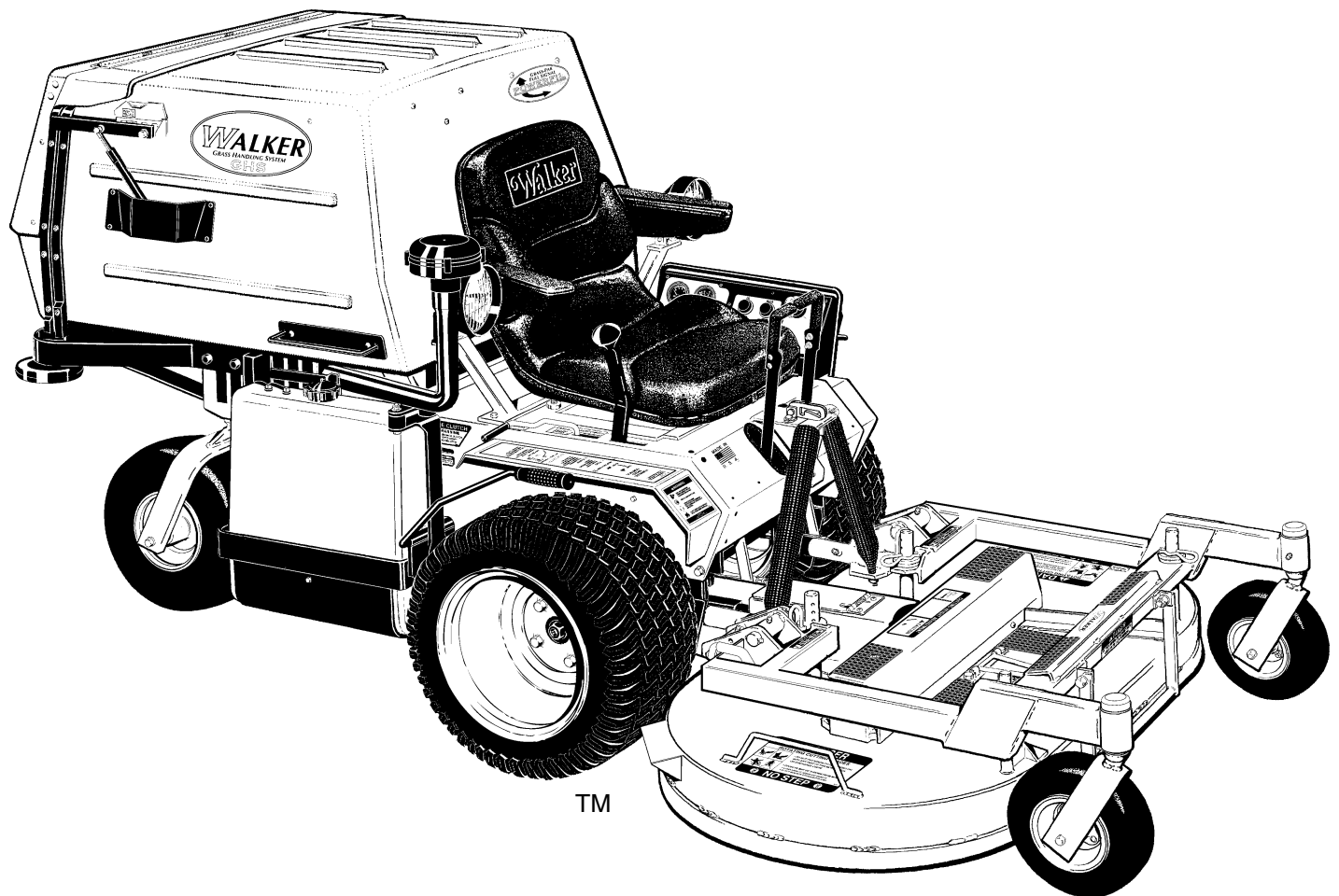

CE

Effective Date:
03-01-03

P/N 7000-5
Price \$5.00

KEY TO ABBREVIATIONS USED IN THIS MANUAL

<i>Abbreviation</i>	<i>What it Represents</i>
° (Dimension)	Degrees (Angle)
" (Dimension)	inches
(-)	Negative (Polarity)
(+)	Positive (Polarity)
AT	All-Terrain
CCW	Counter-clockwise
Conn.	Connector
CW	Clockwise
D	Diameter
DGHS	Deck, Grass Handling System (number refers to size in inches)
DML	Deck, Mulching (number refers to size in inches)
DSD	Deck, Side Discharge (number refers to size in inches)
DU	Garlock (Bearing)
ESNA (Fastener)	Nylon Insert Locknut
FSC	Forward Speed Control
GA	Gauge
gal.	gallon
GHS	Grass Handling System
GR (Fastener)	Grade
HP	Horse Power
HT	Heat-Treated
ID	Identification or Inside Diameter
L	Length
LH	Left Hand (orientated with operator on seat)
LP	Low Profile
mm (Dimension)	millimeters
MS (Fastener)	Machine Screw
NS (as part number)	Item is not sold by Walker Manufacturing
OD	Outside Diameter
oz.	ounce
PFH (Fastener)	Phillips Flat Head
P/N	Part Number
PPH (Fastener)	Phillips Pan Head
PTH (Fastener)	Phillips Truss Head
PTO	Power Take-Off
QKS	Quick Slide
qt.	quart
RH	Right Hand (orientated with operator on seat)
SAE (Fastener)	Society of Automotive Engineers
SBH (Fastener)	Socket Button Head (Bolt)
SD	Side Discharge
SFH (Fastener)	Slotted Flat Head
SHC (Fastener)	Socket Head Cap
SHL (Fastener)	Shoulder (Bolt)
SM (Fastener)	Sheet Metal (Screw)
S/N	Serial Number
Spg	Spring
SQH (Fastener)	Square Head
SS (Fastener)	Stainless Steel
ST (Fastener)	Self-Tapping (Screw)
Term.	Terminal
V	Volts

NOTE: In some instances, combinations of abbreviations may be used (e.g. PPHMS - Phillips Pan Head Machine Screw).

Use only genuine **Walker**[®] replacement parts.

Effective Date 03-01-03

ILLUSTRATED PARTS LIST

<i>Section of Mower Covered</i>	<i>Page</i>	<i>Section of Mower Covered</i>	<i>Page</i>
Decals		Options and Kits	
Tractor Decals	2	Power Deck Lift Kit	44
Body / Chassis Assemblies		Armrest Kit / Touch-up Paint	46
Body / Chassis Assembly (GHS Models)	4	Comfort Seat / Armrest Kit	48
Rear Body Assembly (GHS Models)	6	Suspension Seat Kit	50
Body Assembly (SD Models)	8	Light Kit	52
Tractor Components		Case-hardened Blower Kit	54
Main Component Power Transmission		Speed Up Kit	56
(GHS Models)	10	Power Dump Kit	
(SD MODELS)	12	(7.0 Bushel GHS Models Only)	58
Engine Group	14	(9.5 Bushel GHS Models Only)	60
Air Intake And Exhaust Group	16	No Catch Deflector Kit	
Radiator Group	18	(7.0 Bushel & 9.5 Bushel)	62
Hydrostatic Ground Drive Assemblies	20	Tail Weight Kit	64
Steering Control Assemblies	22	Tail Wheel Lock Kit	66
Throttle Control Assemblies	24	Wide Tail Wheel / All-terrain Tire Kit &	
Parking Brake Assembly	26	Tire Chain Set	68
GHS Group	28	Maintenance	
GHS Powerfil® Assembly	30	Lubrication Points	70
GHS 7.0 Bushel Catcher &		Wiring Schematic	72
Exhaust Deflector Assemblies	32	Warranty	
GHS 9.5 Bushel Catcher Assembly	34	Limited Warranty.....	73
Instrument Panel Assembly	36		
Electrical Components			
Electrical Assembly	38		
Electrical Assemblies			
(GHS 7.0 / 9.5 Bushel Components)	40		
Electrical Connectors	42		

TRACTOR DECALS

ITEM NO.	PART NO.	DESCRIPTION	LOCATION	NO. REQ'D. GHS	NO. REQ'D SD
Walker Product Decals					
1	7802	RH Fender	Body, RH Side near Seat	1	1
2	5856	Made in USA	Body, Spring Bracket	1	1
3	5803	Walker Manufacturing Logo	Body	1	1
4	5813-1	Powerfil®	7.0 / 9.5 Bushel Catcher, Front	1	0
5	5801	GHS	7.0 / 9.5 Bushel Catcher (one on each side)	2	0
6	5800	Walker Mower (4 x 7-1/2)	Utility Bed (one on each side)	0	2
7	5806	Blade Clutch	Body, RH Side	1	1
Danger Decals Warning Decals Caution Decals					
8	5804	Blower Blade Warning	Body near Body Chute	1	0
9	7818	Warning, Read Manual	Body	1	1
10	5868	Danger, Pinch Point	7.0 / 9.5 Bushel Catcher Mounting Frame Assembly (one on each side)	2	0
Maintenance Decals					
11	7809	Parking Brake	Body, RH Side below Seat	1	1
12	7820	Body Release Decal	Body, RH Side	1	1
13	7819	Throttle	Body, LH Side	1	1
14	5810-2	Reservoir	Hydrostatic Drives (one on each)	2	2
15	5810-1	Axle Oil Level	Gear Axle Drive Assemblies (one on each)	2	2
16	5819	Blower Maintenance	Blower Housing	1	0
17	6875	PTO Alignment Arrow	Universal Joint Tube Assembly	1	1
18	7827	Oil Level	Jackshaft Support	1	1
19	5874	Push to Release	7.0 / 9.5 Bushel Catcher Safety Latch	1	0
20	8825	Front Body Closure	Rear Cross Member, Body	1	1
21	5869	Removable Screen	7.0 / 9.5 Bushel Catcher Removable Screen	1	0
22	NS	Caution (19426-87881 Kubota)	Radiator	1	1
23	NS	Caution (19426-87903 Kubota)	Air Cleaner Cover	1	1
Option Decals*					
24	7633	Power Dump Switch	Body	1	0
25	8555	Tail Wheel Lock	FSC Lever Assembly - Switch Mount Bracket	1	1
26	8654	Power Deck Lift	Body, RH Side	1	1

* Option Decals applied only to units with corresponding Options installed.

NOTE: All parts requiring decals are shipped with decals applied.

TRACTOR DECALS

SD Model

*Refer to Decks
Parts Manual
for Deck Decals*

GHS Model

*Refer to Decks
Parts Manual
for Deck Decals*

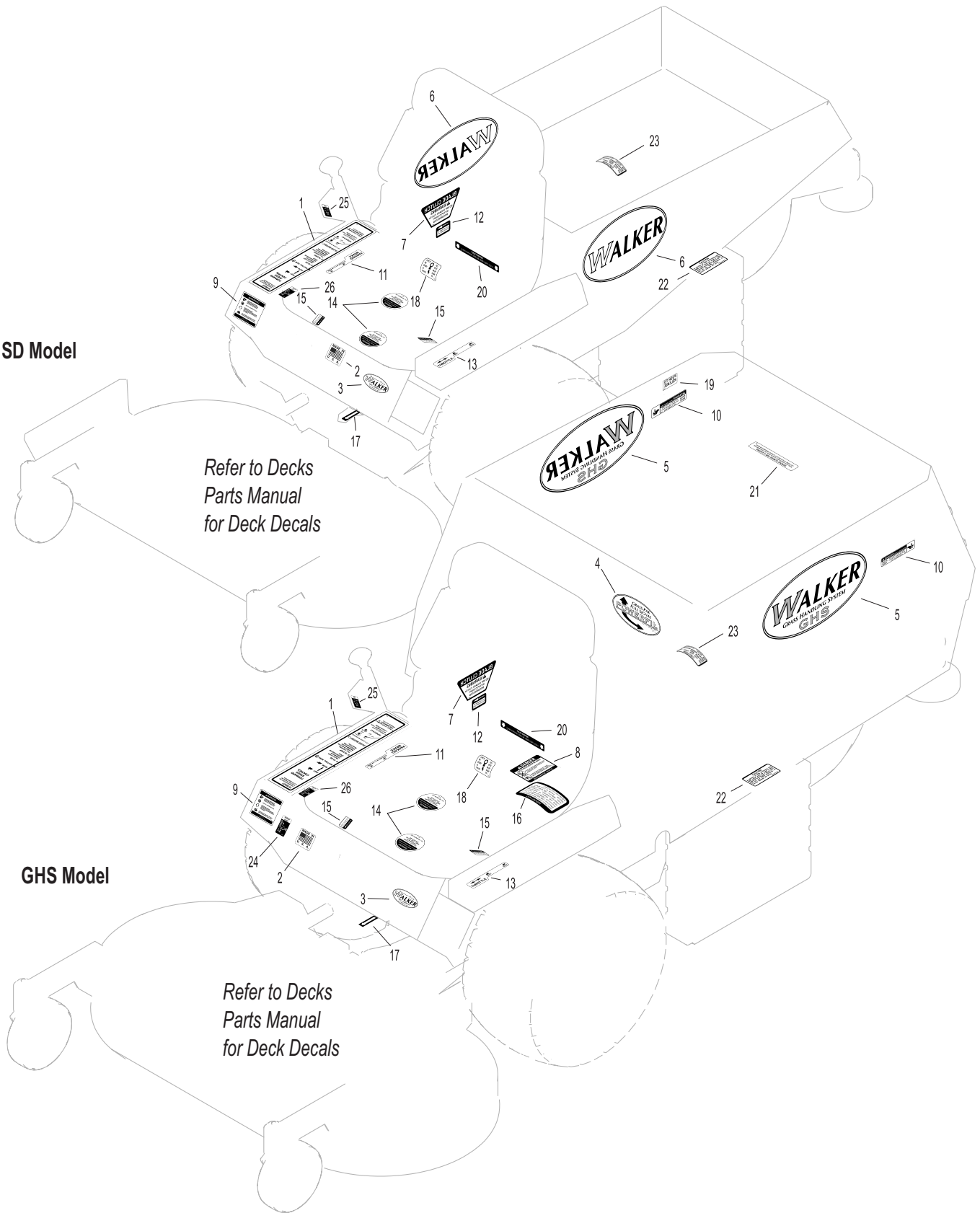

BODY / CHASSIS ASSEMBLY (GHS MODELS)

ITEM NO.	PART NO.	DESCRIPTION	NO. REQ'D	ITEM NO.	PART NO.	DESCRIPTION	NO. REQ'D
Seat Assembly				43	8039	Nut, Tail Wheel Axle	2
1	5103	Seat	1	44	8037-1	Seal, Tail Wheel Axle	4
2	7203	Seat Spring Plate	1	45	8038-1	Spacer, Tail Wheel Axle	2
3	7223	Compression Spring (1/2 x 1)	2	46	8037	Bearing Cone (3/4 ID)	4
4	7845	Rubber Bumper (1.375 OD x .63)	2	47	8037-2	Bearing Race	4
5	7846	Rubber Washer (3/8 ID x 1-1/4 OD x 1/8)	2	48	8035	Tail Wheel & Tire (13 x 5.00-6)	2
6	7204	Shoulder Bolt, Seat Mount	2			(With Bearing Race)	
7	7440-5	Shock Mount (1.25 D x .75)	2		7035-1	Tail Wheel Tire (13 x 5.00-6)	**
Rear Bumper Assembly (GHS Models Only)*					8036	Tail Wheel & Hub (6 x 3.25)	**
8	NS	Recovery Tank Mount (19449-72502 Kubota)	1			(Includes Items # 41 & 47)	
9	7047-5	Mount Plate	1	49	8038	Tail Wheel Axle (3/4 x 10-3/8)	1
10	7516-7	7.0 / 9.5 Rear Bumper	1	50	7070	Wheel & Tire Assembly (18 x 9.5-8)	2
11	7516-5	Catcher Pivot Bushing	2		7070-1	DriveTire (18 x 9.5-8)	**
12	5162	Roller Wheel (5" Rubber)	2		5070-4	Wide Wheel (8 x 7)	**
13	7517-2	Catcher Pivot Plate	2	51	7300-5	Chassis Frame	1
14	5832	Cable Clamp (1/2)	2	Fasteners			
Body Assembly					F002	10-24 Keps Nut	2
15	NS	Body ID Plate	1		F004	1/4-20 Keps Nut	2
16	5845	Rubber Bumper (1.50 OD x 1.25)	4		F005	1/4-20 ESNA Nut	1
17	7422	Panel Guard	1		F009	5/16-18 Whiz Locknut	13
18	5989-4	Dome Plug (3/8)	4		F012	3/8-16 Keps Nut	8
19	5989-3	Dome Plug (5/16)	2		F013	3/8-16 Whiz Locknut	2
20	7146	13mm Ball Stud	2		F014	3/8-16 ESNA Nut	4
21	7844	Rubber Bumper (1.25 OD x .25)	1		F020	5/16-18 ESNA Nut	1
22	7147	Spring Clip	2		F026	10-24 x 1/2 PPHMS	2
23	7145	Gas Spring Assembly (Includes Items # 18 & 20)	1		F029	1/4-20 x 1/2 Hex Bolt	2
24	7222	Spring, Body Release	1		F031	1/4-20 x 5/8 Hex Bolt	1
25	7383-1	Body Latch Hook	1		F034	5/16-18 x 3/4 Hex Bolt	2
26	7854	Plastic Tip, Red	1		F038	3/8-16 x 1 Hex Bolt	6
27	5989-9	Dome Plug (1/4)	10		F040	3/8-16 x 1-1/2 Hex Bolt	2
28	7100	Front Body	1		F042	3/8-16 x 2-1/4 Hex Bolt	2
29	5180	Edge Molding, Lever Opening	2		F050	1/4 SAE Washer	1
30	5989-5	Dome Plug (7/16)	1		F051	3/8 SAE Washer	2
Tilt-Up Latch Assembly					F059	3/8 Wave Spring Washer	2
31	5847	Plastic Tip	1		F093	5/16-18 x 1 Hex Bolt	1
32	5744-20	Spring Arm, Tilt-Up Latch	1		F104	1/4-20 x 3/4 PFH Bolt	4
33	5744-10	Spring Pivot Bushing	1		F113	5/16-18 x 5/16 Set Screw	2
34	5744-15	Compression Spring (3/8 x 5/8)	1		F151	3/8-16 x 7/8 Hex Bolt	2
35	5744-13	Mount Angle, LH	1		F157	1/2-20 x 1-1/4 Wheel Lug Bolt	8
36	5744-12	Hook, Tilt-Up Latch	1		F205	5/16-18 x 1/4 Set Screw, Knurl Point	2
37	5744-14	Mount Angle, RH	1		F206	#2 x 3/16 Drive Pin	2
Chassis Assembly					F218	7/16 Split Lock Washer	2
38	5267-1	Retainer Collar (1") (Includes Item # F113)	1		F219	7/16-14 x 1-1/4 Hex Bolt	2
39	5270-1	Pivot Bearing	2		F227	3/8 x 1-1/4 x 1/8 Plastic Washer	2
40	5842-1	Washer, Axle Spacer	1		F241	.375 x .875 x .10 Washer	4
41	7420	Tail Wheel Fork	1		F341	Coil Roll Pin (7/64 x 9/16)	1
42	5830-3	Grease Fitting (45 Degree)	2		F342	5/16 Conical Washer	2

* Rear Bumper Assembly for SD Models is not shown here. Refer to **BODY ASSEMBLY (SD MODELS)**, Page 8.

** Service Part Only

Use only genuine **Walker**[®] replacement parts.

Effective Date 03-01-03

BODY / CHASSIS ASSEMBLY (GHS MODELS)

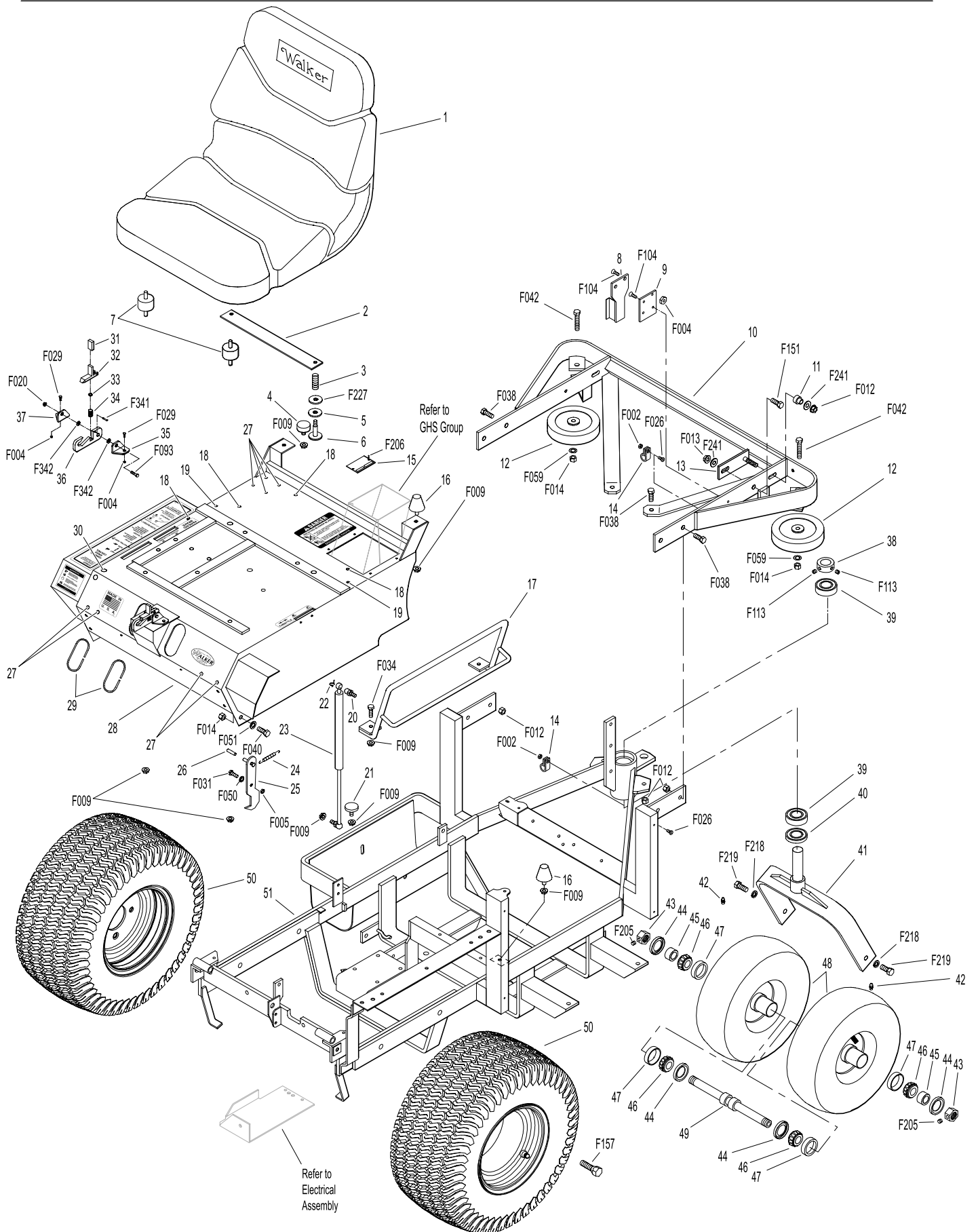

Effective Date 03-01-03

Use only genuine Walker® replacement parts.

REAR BODY ASSEMBLY (GHS MODELS)

ITEM NO.	PART NO.	DESCRIPTION	NO. REQ'D	ITEM NO.	PART NO.	DESCRIPTION	NO. REQ'D
Rear Body Assembly (GHS Models)				Fasteners			
1	8515-10	Catcher Reinforcing Plate	2	F002		10-24 Keps Nut	6
2	7515-2	Catcher Support Frame	1	F004		1/4-20 Keps Nut	5
3	7190-2	Insulation Foam Pad, RH	1	F009		5/16-18 Whiz Locknut	4
4	7190-1	Insulation Foam Pad, LH	1	F025		10-24 x 3/8 PPHMS	6
5	7145	Gas Spring Assembly (Includes Items # 6 & 7)	1	F031		1/4-20 x 5/8 Hex Bolt	2
6	7147	Spring Clip	2	F032		1/4-20 x 3/4 Hex Bolt	3
7	7146	13mm Ball Stud	2	F178		1/4 x 1 Fender Washer	1
8	5845	Rubber Bumper (1.50 x 1.25)	1				
9	7105-5	Rear Body Panel	1				

NOTE: Rear Bumper Assembly for GHS Models is not shown here. Refer to **BODY / CHASSIS ASSEMBLY (GHS MODELS)**, Page 4.

NOTE: Decals for this assembly are not shown here. Refer to **TRACTOR DECALS** (Page 2) for Decal listing and placement information.

REAR BODY ASSEMBLY (GHS MODELS)

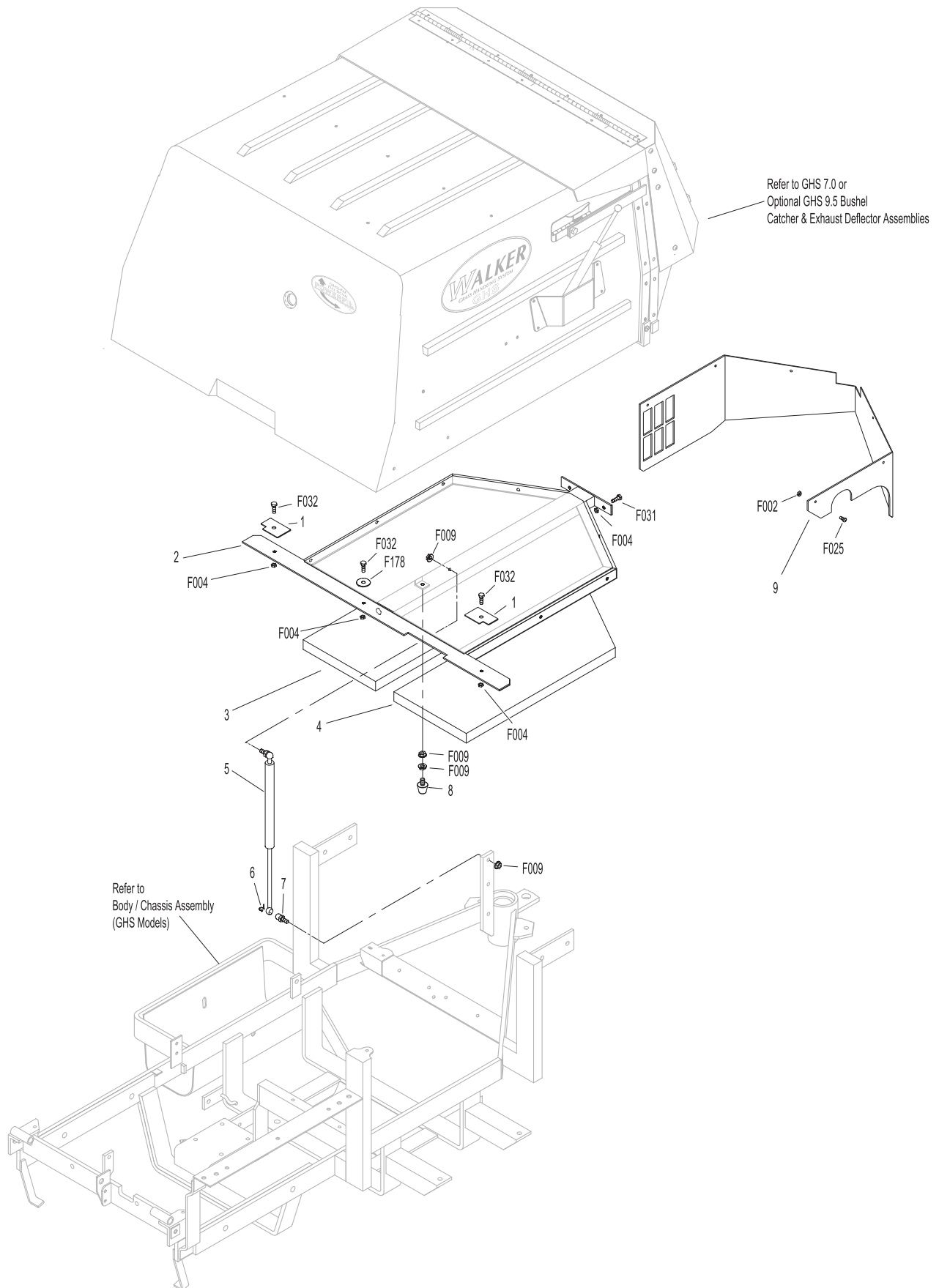

BODY ASSEMBLY (SD MODELS)

ITEM NO.	PART NO.	DESCRIPTION	NO. REQ'D	ITEM NO.	PART NO.	DESCRIPTION	NO. REQ'D
Utility Bed Assembly				Fasteners			
1	8650-10	Bed Liner	1	F002		10-24 Keps Nut	11
2	7650-3	Utility Bed	1	F004		1/4-20 Keps Nut	4
3	7190-2	Insulation Foam Pad, RH	1	F009		5/16-18 Whiz Locknut	2
4	7190-1	Insulation Foam Pad, LH	1	F012		3/8-16 Keps Nut	6
Rear Bumper Assembly (SD Models)				F013		3/8-16 Whiz Locknut	4
5	7153-3	Cover Plate	1	F014		3/8-16 ESNA Nut	2
6	7145	Gas Spring Assembly (Includes Items # 7 & 8)	1	F025		10-24 x 3/8 PPHMS	6
7	7147	Spring Clip	2	F026		10-24 x 1/2 PPHMS	1
8	7146	13mm Ball Stud	2	F038		3/8-16 x 1 Hex Bolt	6
9	7521	Rear Bumper	1	F040		3/8-16 x 1-1/2 Hex Bolt	2
10	NS	Recovery Tank Mount (19449-72502 Kubota)	1	F042		3/8-16 x 2-1/4 Hex Bolt	2
11	7047-5	Mount Plate	1	F051		3/8 SAE Washer	4
12	5832	Cable Clamp (1/2)	2	F059		3/8 Wave Spring Washer	2
13	5162	Roller Wheel (5" Rubber)	2	F104		1/4-20 x 3/4 PFH Bolt	4
14	7105-5	Rear Body Panel	1	F128		10-24 x 3/8 PTHMS	4

NOTE: Refer to **BODY / CHASSIS ASSEMBLY (GHS MODELS)**,
Page 4 for all common parts used on both models.

BODY ASSEMBLY (SD MODELS)

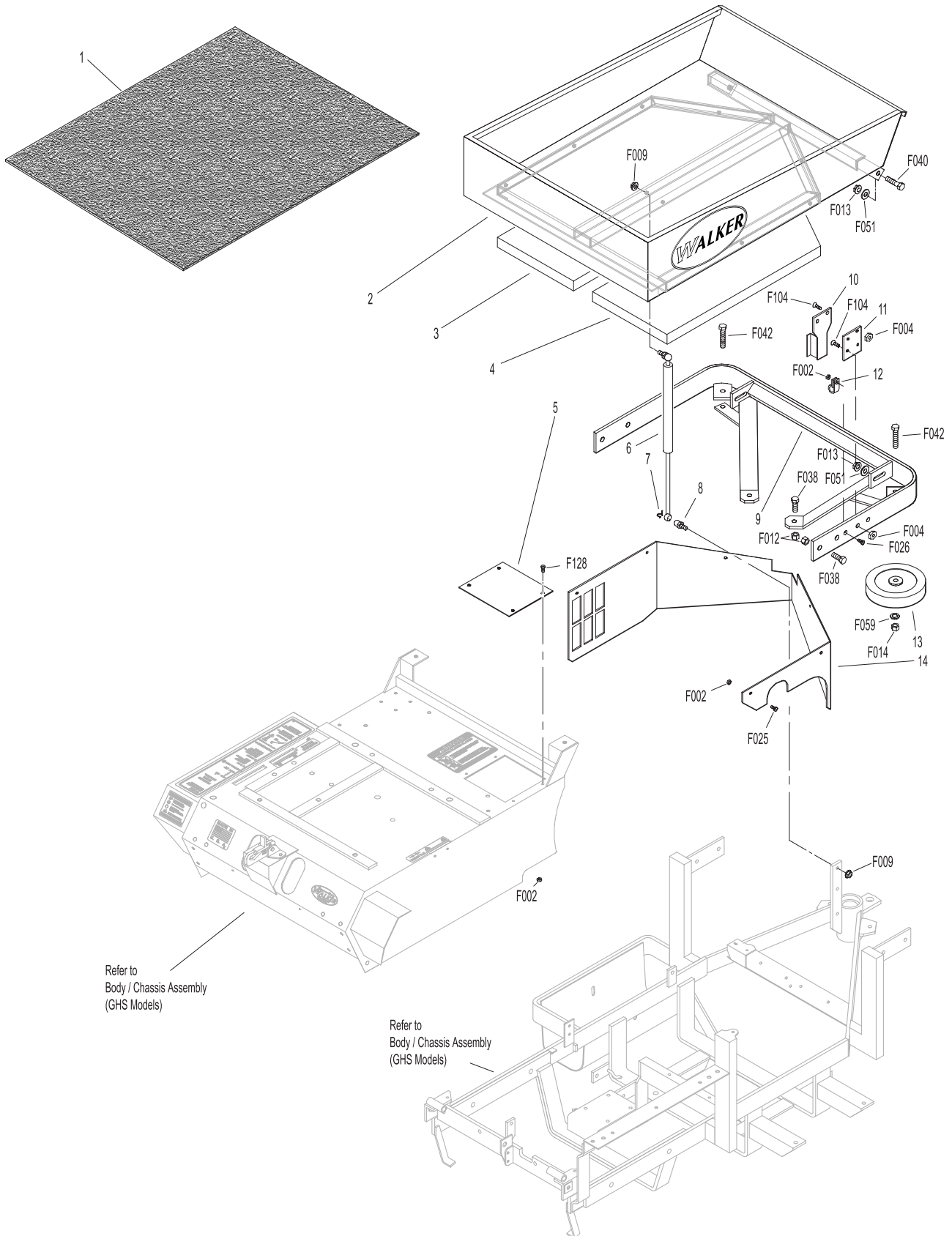

MAIN COMPONENT POWER TRANSMISSION (GHS MODELS)

ITEM NO.	PART NO.	DESCRIPTION	NO. REQ'D	ITEM NO.	PART NO.	DESCRIPTION	NO. REQ'D
Clutch Lever Assembly				Ground Drive Release Assembly			
1	5830	Grease Fitting	4	38	7245-1	Idler Pulley (3/8 Groove)	1
2	5229	Extension Spring (1/2 x 2-1/4)	1	39	7374	Ground Drive Tightener Arm	1
3	7243	Clutch Idler Pulley	1	40	7390	Idler Arm Guide	1
4	7368-2	PTO Belt Tightener (1-3/4)	1	41	7406-1	Handle Grip, Red	1
5	7201-3	DU Bearing	6	42	7376	Handle, Ground Release (Includes Item # 41)	1
6	7201-6	Inner Race (3-5/8)	1	43	5221	Extension Spring (3/4 x 4)	1
7	7303-9	Clutch Actuator Block	1	44	7854	Plastic Tip, Red	1
8	7226	Compression Spring (3/4 x 2-1/2)	1	45	7375	Ground Drive Release Arm (Includes Item # 44)	1
9	7380	Knuckle Joint	1	46	7225	Spring, GD Release	1
10	5830-3	Grease Fitting (45 Degree)	1	Fasteners			
11	7303-7	Clutch Actuator Rod	1	F002	10-24 Keps Nut		2
12	7378	Pivot Bearing (7/16 x 9/16)	1	F004	1/4-20 Keps Nut		4
13	7358	Clutch Lever (Includes Items # 1 & 16)	1	F005	1/4-20 ESNA Nut		2
14	7860	Handle Grip	1	F009	5/16-18 Whiz Locknut		3
PTO Drive Shaft Assembly				F012	3/8-16 Keps Nut		5
15	5832	Cable Clamp (1/2)	1	F013	3/8-16 Whiz Locknut		2
16	7857	Mount Bracket	1	F026	10-24 x 1/2 PPHMS		1
17	7050-1	Dipstick, Gearbox	1	F029	1/4-20 x 1/2 Hex Bolt		1
18	8377	Brake Band Guide	1	F035	5/16-18 x 1-1/4 Hex Bolt		2
19	7050-11	PTO Gearbox	1	F040	3/8-16 x 1-1/2 Hex Bolt		1
20	5245	Idler Pulley (3")	2	F041	3/8-16 x 1-3/4 Hex Bolt		1
21	7248	Ground Drive Belt, Micro-V	1	F042	3/8-16 x 2-1/4 Hex Bolt		2
22	7275-15	Universal Joint Tube Assembly	1	F047	3/8-16 x 4-1/2 Hex Bolt		1
23	7303-2	Brake Band (13-5/8)	1	F050	1/4 SAE Washer		1
24	7236-1	PTO Drive Pulley (4-1/2 / 3V) (Includes Items # F226 & F168)	1	F060	AN960516 Washer		2
25	7237-30	Engine Pulley (Flywheel Mount) (Includes Item # F221)	1	F061	1/4 Internal Star Lock Washer		1
26	7230	Engine PTO Belt (AX44)	1	F067	3/16 x 3/16 x 1 Key		2
27	6231	Engine Jackshaft Belt (3VX335)	1	F069	3/32 x 1/2 Cotter Pin		1
Jackshaft Assembly				F076	3/8-16 x 5/8 SQH Set Screw		1
28	7240-3	Jackshaft Drive Pulley (4.15/3V) (Includes Items # F171 & F067)	1	F091	5/16-18 x 5/8 Hex Bolt		1
29	5268	Bearing (3/4)	2	F108	3/8-16 x 2 Hex Bolt		1
30	7273	Jackshaft (3/4 x 8-7/8)	1	F116	1/4-20 x 1-1/4 Hex Bolt		1
31	7393-2	Jackshaft Mount	1	F132	1/4-20 x 2-3/4 Hex Bolt		2
32	5841	Retainer Washer	1	F167	5/16-18 Hex Nut		1
33	7201-4	Inner Race (1-1/2)	2	F168	5/16 Split Lock Washer		5
34	7349-50	Idler Arm	1	F171	5/16-18 x 3/8 Set Screw		4
35	7349-2	Belt Tension Spring	1	F178	1/4 x 1 Fender Washer		1
36	6325-3	Spacer Bushing (9/16)	1	F187	1/4-20 x 1-1/2 Hex Bolt		2
37	7241-2	Transmission Drive Pulley (3-1/4 / Micro-V) (Includes Item # F171 and F067)	1	F221	M8 x 1.25 x 16 PFH Bolt		5
				F226	5/16-18 x 7/8 Hex Bolt		4
				F245	3/8-24 x 7/8 SFH Cap Screw		1
				F252	10-24 x 3/4 PPHMS		1
				F275	5/16-18 x 2 Hex Bolt		1
				F288	5/16-18 ESNA Jam Nut		1

Use only genuine **Walker**[®] replacement parts.

Effective Date 03-01-03

MAIN COMPONENT POWER TRANSMISSION (GHS MODELS)

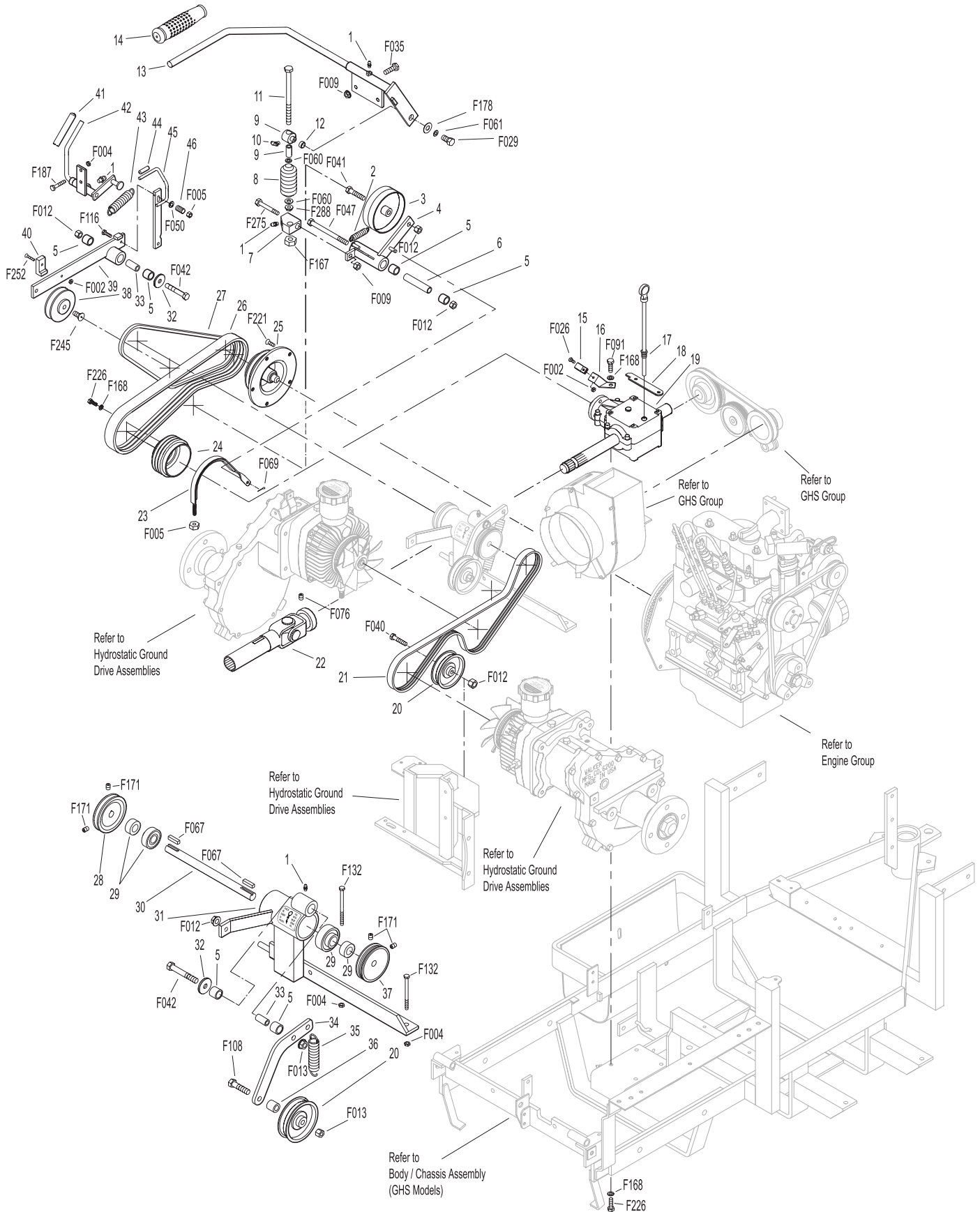

Effective Date 03-01-03

Use only genuine **Walker**® replacement parts.

MAIN COMPONENT POWER TRANSMISSION (SD MODELS)

ITEM NO.	PART NO.	DESCRIPTION	NO. REQ'D	ITEM NO.	PART NO.	DESCRIPTION	NO. REQ'D
Clutch Lever Assembly				Ground Drive Release Assembly			
1	5830	Grease Fitting	4	38	7245-1	Idler Pulley (3/8 Groove)	1
2	5229	Extension Spring (1/2 x 2-1/4)	1	39	7374	Ground Drive Tightener Arm	1
3	7243	Clutch Idler Pulley	1	40	7390	Idler Arm Guide	1
4	7368-2	PTO Belt Tightener (1-3/4)	1	41	7406-1	Handle Grip, Red	1
5	7201-3	DU Bearing	6	42	7376	Handle, Ground Release (Includes Item # 41)	1
6	7201-6	Inner Race (3-5/8)	1	43	5221	Extension Spring (3/4 x 4)	1
7	7303-9	Clutch Actuator Block	1	44	7854	Plastic Tip, Red	1
8	7226	Compression Spring (3/4 x 2-1/2)	1	45	7375	Ground Drive Release Arm (Includes Item # 44)	1
9	7380	Knuckle Joint	1	46	7225	Spring, GD Release	1
10	5830-3	Grease Fitting (45 Degree)	1	Fasteners			
11	7303-7	Clutch Actuator Rod	1	F002	10-24 Keps Nut		2
12	7378	Pivot Bearing (7/16 x 9/16)	1	F004	1/4-20 Keps Nut		4
13	7358	Clutch Lever (Includes Items # 1 & 16)	1	F005	1/4-20 ESNA Nut		2
14	7860	Handle Grip	1	F009	5/16-18 Whiz Locknut		3
PTO Drive Shaft Assembly				F012	3/8-16 Keps Nut		5
15	5832	Cable Clamp (1/2)	1	F013	3/8-16 Whiz Locknut		2
16	7857	Mount Bracket	1	F026	10-24 x 1/2 PPHMS		1
17	7050-1	Dipstick, Gearbox	1	F029	1/4-20 x 1/2 Hex Bolt		1
18	8377	Brake Band Guide	1	F035	5/16-18 x 1-1/4 Hex Bolt		2
19	7050-11	PTO Gearbox	1	F040	3/8-16 x 1-1/2 Hex Bolt		1
20	5245	Idler Pulley (3")	2	F041	3/8-16 x 1-3/4 Hex Bolt		1
21	7248	Ground Drive Belt, Micro-V	1	F042	3/8-16 x 2-1/4 Hex Bolt		2
22	7275-15	Universal Joint Tube Assembly	1	F047	3/8-16 x 4-1/2 Hex Bolt		1
23	7303-2	Brake Band (13-5/8)	1	F050	1/4 SAE Washer		1
24	7236-1	PTO Drive Pulley (4-1/2 / 3V) (Includes Items # F226 & F168)	1	F060	AN960516 Washer		2
25	7237-30	Engine Pulley (Flywheel Mount) (Includes Item # F221)	1	F061	1/4 Internal Star Lock Washer		1
26	7230	Engine PTO Belt (AX44)	1	F067	3/16 x 3/16 x 1 Key		2
27	6231	Engine Jackshaft Belt (3VX335)	1	F069	3/32 x 1/2 Cotter Pin		1
Jackshaft Assembly				F076	3/8-16 x 5/8 SQH Set Screw		1
28	7240-3	Jackshaft Drive Pulley (4.15/3V) (Includes Items # F171 & F067)	1	F091	5/16-18 x 5/8 Hex Bolt		1
29	5268	Bearing (3/4)	2	F108	3/8-16 x 2 Hex Bolt		1
30	7273	Jackshaft (3/4 x 8-7/8)	1	F116	1/4-20 x 1-1/4 Hex Bolt		1
31	7393-2	Jackshaft Mount	1	F132	1/4-20 x 2-3/4 Hex Bolt		2
32	5841	Retainer Washer	1	F167	5/16-18 Hex Nut		1
33	7201-4	Inner Race (1-1/2)	2	F168	5/16 Split Lock Washer		5
34	7349-50	Idler Arm	1	F171	5/16-18 x 3/8 Set Screw		4
35	7349-2	Belt Tension Spring	1	F178	1/4 x 1 Fender Washer		1
36	6325-3	Spacer Bushing (9/16)	1	F187	1/4-20 x 1-1/2 Hex Bolt		2
37	7241-2	Transmission Drive Pulley (3-1/4 / Micro-V) (Includes Item # F171 and F067)	1	F221	M8 x 1.25 x 16 PFH Bolt		5
				F226	5/16-18 x 7/8 Hex Bolt		4
				F245	3/8-24 x 7/8 SFH Cap Screw		1
				F252	10-24 x 3/4 PPHMS		1
				F275	5/16-18 x 2 Hex Bolt		1
				F288	5/16-18 ESNA Jam Nut		1

Use only genuine **Walker**[®] replacement parts.

Effective Date 03-01-03

MAIN COMPONENT POWER TRANSMISSION (SD MODELS)

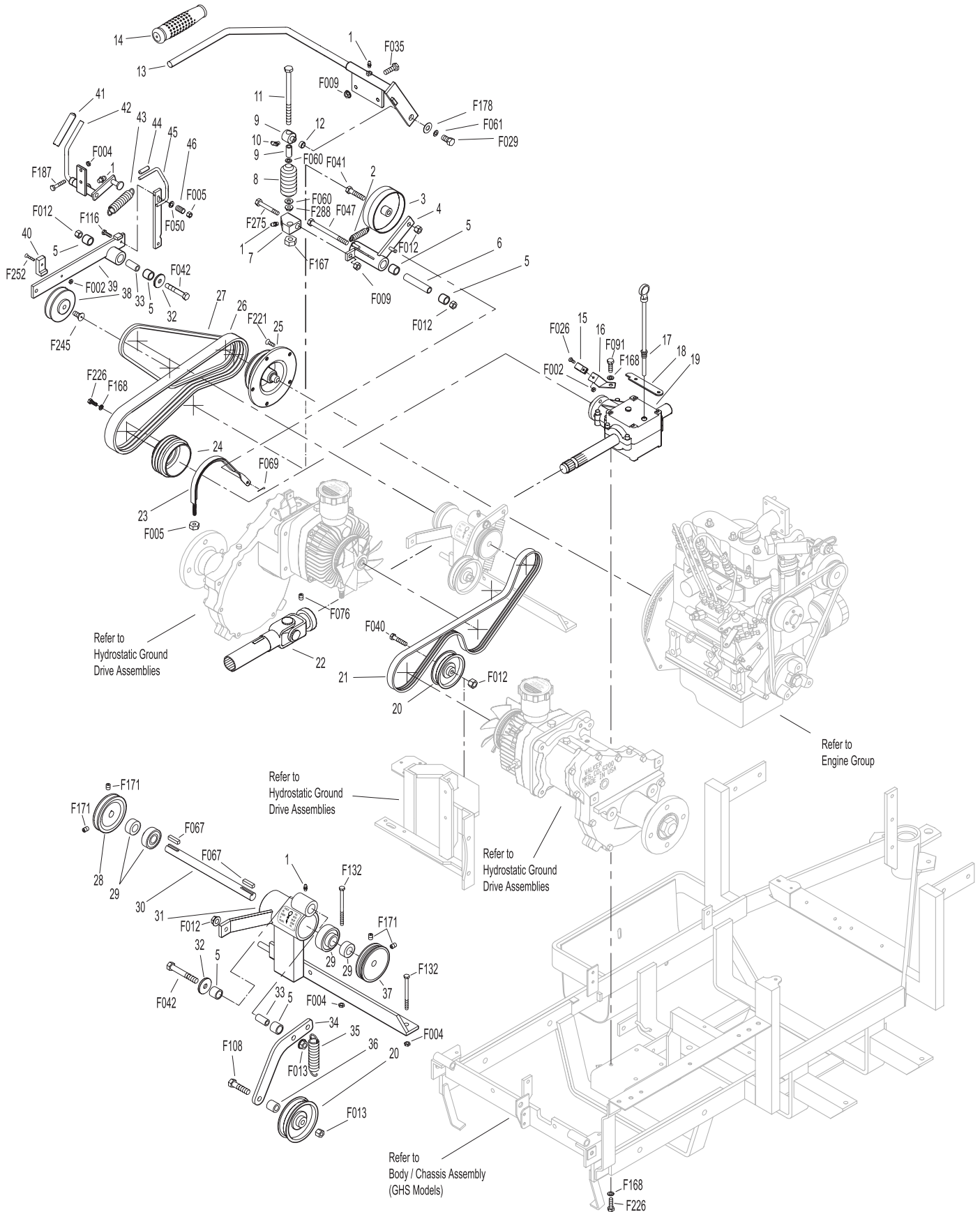

ENGINE GROUP

ITEM NO.	PART NO.	DESCRIPTION	NO. REQ'D	ITEM NO.	PART NO.	DESCRIPTION	NO. REQ'D
Engine Assembly				25	5020-1	Fuel Filter, In Tank	1
1	7929	Actuating Solenoid	1	26	5086	Fuel Line (In Tank P/U)	1
2	7343	Solenoid Mount	1	27	5083-1	Bushing, Rubber	*
3	7305	Solenoid Linkage Rod	1	28	7046-1	Fuel Return Tube	1
4	NS	Kubota Diesel Engine (D 722 Kubota)	1	Fasteners			
5	7341	Throttle Cable Mount Bracket	1	F002	10-24 Keps Nut		5
Fuel Tank Assembly				F003	1/4-28 Hex Nut		1
6	5083-2	Tank Tube Elbow	1	F004	1/4-20 Keps Nut		6
7	5879-3	Hose Clamp (1/2)	3	F009	5/16-18 Whiz Locknut		2
8	7015-14	Fuel Line, Tank (1/4 x 16-1/2)	1	F027	10-24 x 5/8 PPHMS		3
9	7833	Cable Clamp (7/8 x 1/4)	3	F029	1/4-20 x 1/2 Hex Bolt		4
10	7015-12	Fuel Return Line (3/16 x 32)	1	F031	1/4-20 x 5/8 Hex Bolt		4
11	5879-4	Hose Clamp (7/16)	2	F050	1/4 SAE Washer		1
12	7840-2	Hose Clamp (1/4 to 5/8)	6	F061	1/4 Internal Star Lock Washer		2
13	7015-16	Fuel Line, Pump Out (5/16 x 14-1/2)	1	F069	3/32 x 1/2 Cotter Pin		1
14	NS	Fuel Filter (19204-43010 Kubota)	1	F079	A/A66D Aluminum Pop Rivet		2
15	7015-17	Fuel Line, Engine (5/16 x 25-1/2)	1	F091	5/16-18 x 5/8 Hex Bolt		1
16	7021	Fuel Filter (15231-43560 Kubota)	1	F182	5/8 x 1/4 x 1/8 Washer		2
17	7389	Splash Guard	1	F233	M8 x 1.25 x 16 Hex Bolt		2
18	8023	Fuel Tank Support	1	F235	5/16-18 x 2-1/2 Hex Bolt		1
19	7015-15	Fuel Line, Pump In (5/16 x 25-1/2)	1	* Service Part Only			
20	NS	Fuel Pump (12691-52031 Kubota)	1	NOTE: Refer to ELECTRICAL CONNECTORS (Page 42) for identification of all Electrical Wiring Service Parts.			
21	7020	Fuel Filter (In-Line)	1	NOTE: Decals for this assembly are not shown here. Refer to TRACTOR DECALS (Page 2) for Decal listing and placement information.			
22	8046-8	Fuel Tank, 5 Gallon, Gas (Includes Items # 26 & 27)	1				
23	5082-2	Fuel Cap Seal	*				
24	5082	Fuel Tank Cap (Includes Item # 26)	*				

ENGINE GROUP

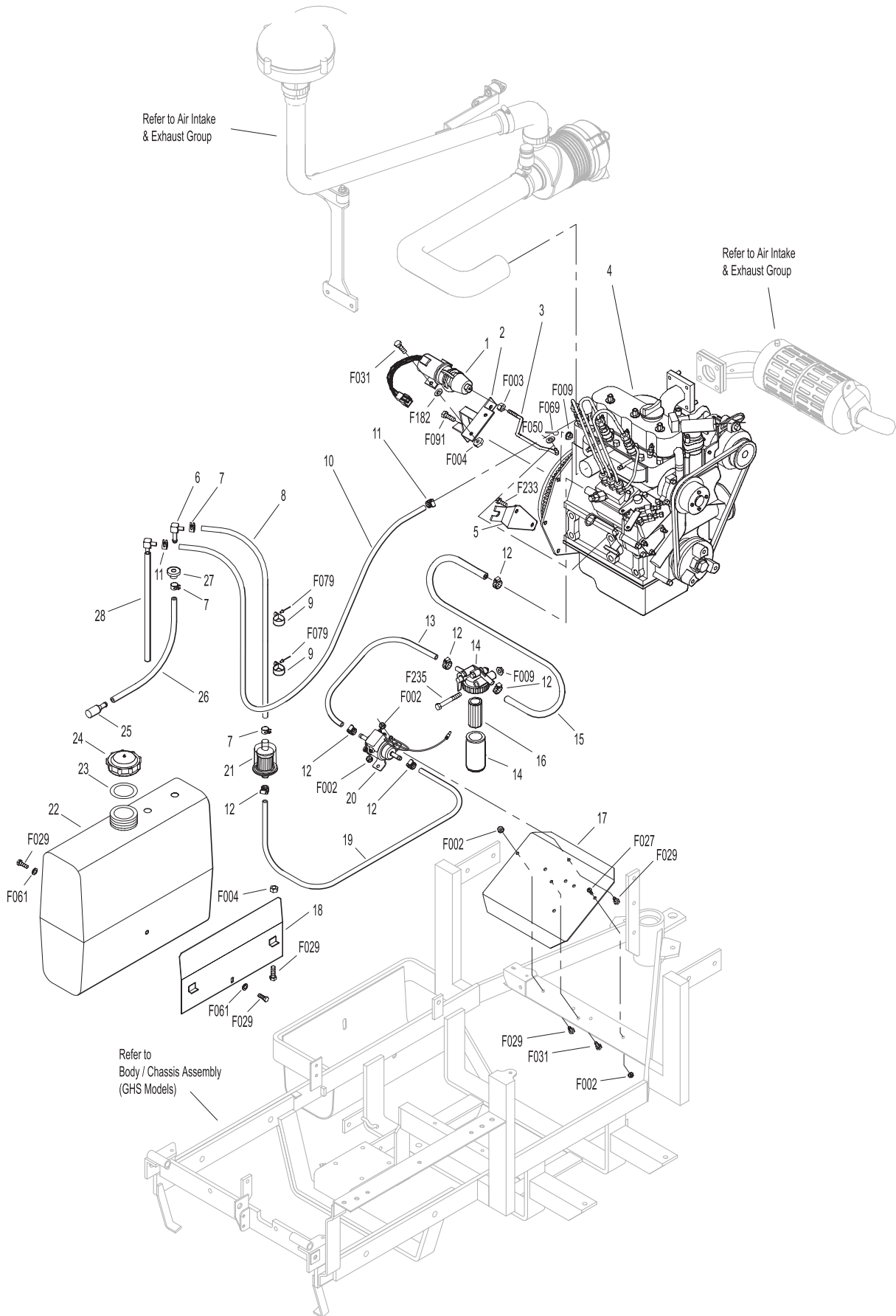

AIR INTAKE AND EXHAUST GROUP

ITEM NO.	PART NO.	DESCRIPTION	NO. REQ'D	ITEM NO.	PART NO.	DESCRIPTION	NO. REQ'D
Precleaner Assembly				Fasteners			
1	7026-2	Remote Precleaner (Includes Item # 5)	1	F002		10-24 Keps Nut	2
2	7440	Shock Mount (1.0 OD x .75)	3	F009		5/16-18 Whiz Locknut	10*
3	7028-20	Rear Precleaner Mount	1	F012		3/8-16 Keps Nut	1
4	7027	Elbow, Precleaner	1	F025		10-24 x 3/8 PPHMS	2
5	7840	Hose Clamp (1-5/16 to 2-1/4)	5	F034		5/16-18 x 3/4 Hex Bolt	1
6	6090-10	Air Cleaner Assembly (Includes Items # 7, 9, 10, 12, 13 & 15)	*	F035		5/16-18 x 1-1/4 Hex Bolt	2*
7	5088-10	Air Cleaner (Includes Item # 9)	1	F038		3/8-16 x 1 Hex Bolt	1**
8	5088-1	Air Cleaner Band	1	F039		3/8-16 x 1-1/4 Hex Bolt	1
9	5090-3	Safety Filter	1	F091		5/16-18 x 5/8 Hex Bolt	2
10	5090-1	Air Cleaner Cartridge	1	F217		7/16-14 Hex Nut	4
11	5088-5	Air Cleaner Draw Latch	1	F218		7/16 Split Lock Washer	4
12	5088-11	Air Cleaner Cap	1	F219		7/16-14 x 1-1/4 Hex Bolt (GHS Models use only 3)	4
13	5090-2	Vacuator Valve	1	F233		M8 x 1.25 x 16 Hex Bolt	2
14	7016	Air Intake Hose	1	F239		7/16-14 x 1-1/2 Hex Bolt	1***
15	5091-10	Air Flow Indicator & Nipple	1	F249		M10 Split Lock Washer	8
16	7031	Tube Support Arm	1	F253		M8 x 1.25 x 35 GR 8 Bolt	3
17	7028-3	Precleaner Tube, SD	1	F311		M10 x 1.25 x 20 Hex Bolt	8
18	7028-2	Precleaner Tube, GHS	1	F327		M8 x 1.25 x 40 GR8 Hex Bolt	1
Exhaust Assembly				* Two (2) F009 and two (2) F035 fasteners are reused from Clutch Lever Assembly. Refer to MAIN COMPONENT POWER TRANSMISSION (GHS OR SD MODELS) , Pages 10 or 12.			
19	7437-1	Exhaust Manifold Shield	1	** One (1) F012 and one (1) F038 fastener are reused from Rear Bumper Assembly. Refer to BODY / CHASSIS ASSEMBLY (GHS MODELS) , Page 4.			
20	NS	Spring Washer (04512-50080 Kubota)	4	*** GHS Models Only			
21	7437-6	Engine Brace	1				
22	NS	Muffler (15262-12110 Kubota)	1				
23	NS	Muffler Gasket (15371-12370 Kubota)	1				
24	7034	Spacer, Muffler	1				
25	7354	Motor Mount	2				
26	7306-4	Water Temperature Sender Unit	1				
27	7306-13	Oil Pressure Switch	1				
28	7023	Oil Filter (15841-32429 Kubota)	1				
29	7047-2	Manifold Heat Shield	1				
30	7013-2	Tail Pipe	1				

AIR INTAKE AND EXHAUST GROUP

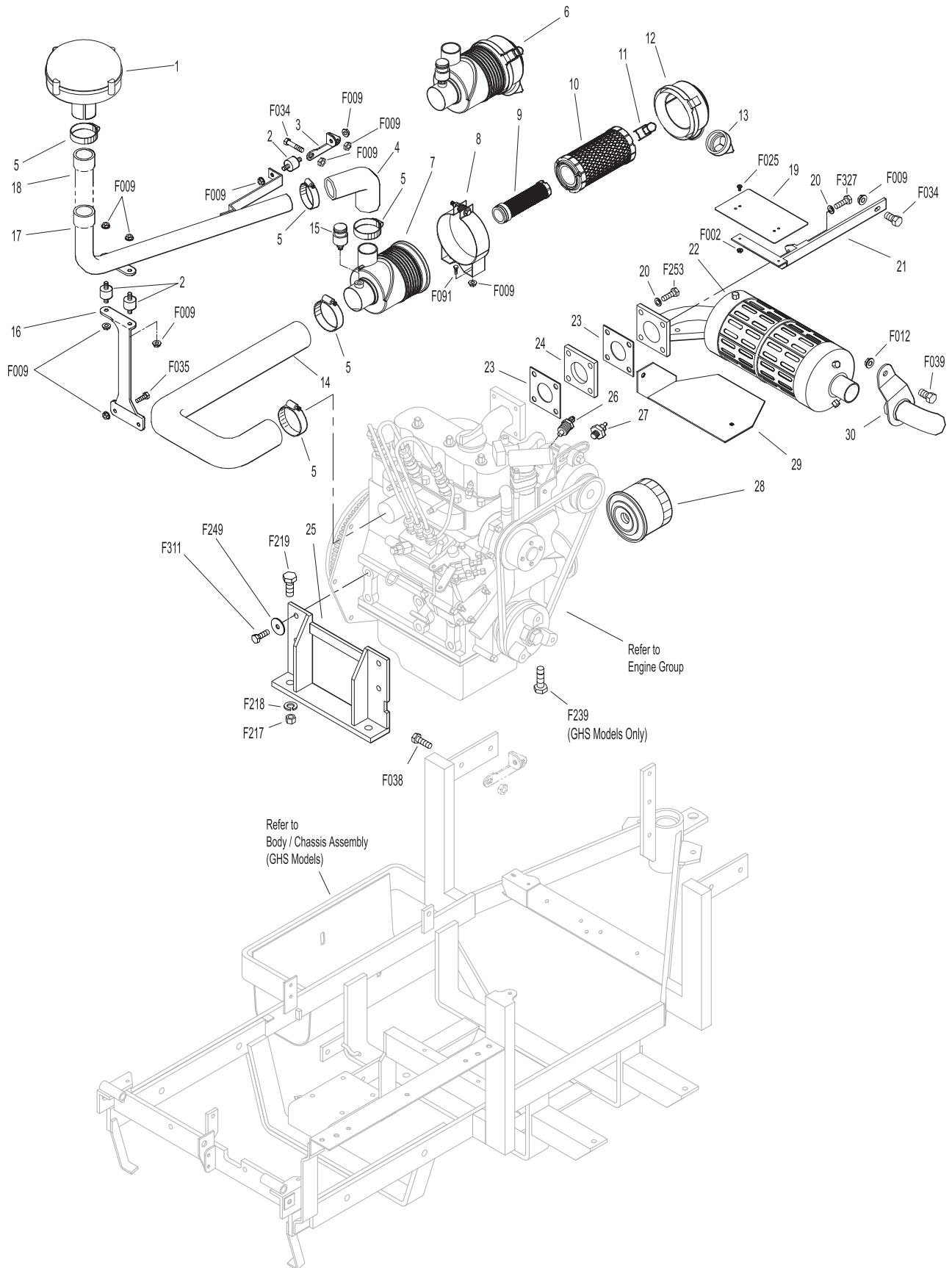

RADIATOR GROUP

ITEM NO.	PART NO.	DESCRIPTION	NO. REQ'D	ITEM NO.	PART NO.	DESCRIPTION	NO. REQ'D
Radiator Assembly				18	7434	Rubber Washer (3/8 x 1-1/4 x 1/4)	4
1	7840-3	Hose Clamp (1/2 to 1-1/4)	2	19	7427-7	Debris Shield, Shroud	1
2	7017-3	Upper Radiator Hose	1	20	7427-22	Fan Mount Tab, RH	2
3	7840-4	Hose Clamp (3/4 to 1-1/2)	2	21	7017-2	Lower Radiator Hose	1
4	7427-21	Fan Mount Tab, LH	2	Fasteners			
5	7429-6	Radiator Cooling Fan	1	F004	1/4-20 Keps Nut		6
6	7427-5	Radiator Fan Shroud	1	F014	3/8-16 ESNA Nut		2
7	NS	Recovery Tank Hose Clamp (15501-72470 Kubota)	2	F029	1/4-20 x 1/2 Hex Bolt		8
8	7015-6	Recovery Tank Hose	1	F031	1/4-20 x 5/8 Hex Bolt		7
9	NS	Coolant Recovery Tank and Hose (19059-72090 Kubota)	1	F061	1/4 Internal Star Lock Washer		7
10	7427	Radiator	1	F073	1/4 x 1.5 Fender Washer		2
11	7431-1	Radiator Channel Seal (1/4 x 1/2 x 13.5)	2	F090	1/4-20 x 2-1/2 Hex Bolt		2
12	7435	Radiator Brace	1	F129	10-24 x 1/2 PTHMS		4
13	7432	Shock Mount (1.00 OD x .75)	1	* GHS Models Only			
14	7425	Radiator Screen	1	NOTE: Decals for this assembly are not shown here. Refer to TRACTOR DECALS (Page 2) for Decal listing and place- ment information.			
15	7426	Screen Channel	2				
16	7430	Radiator Guard	1				
17	5841	Retainer Washer	2				

RADIATOR GROUP

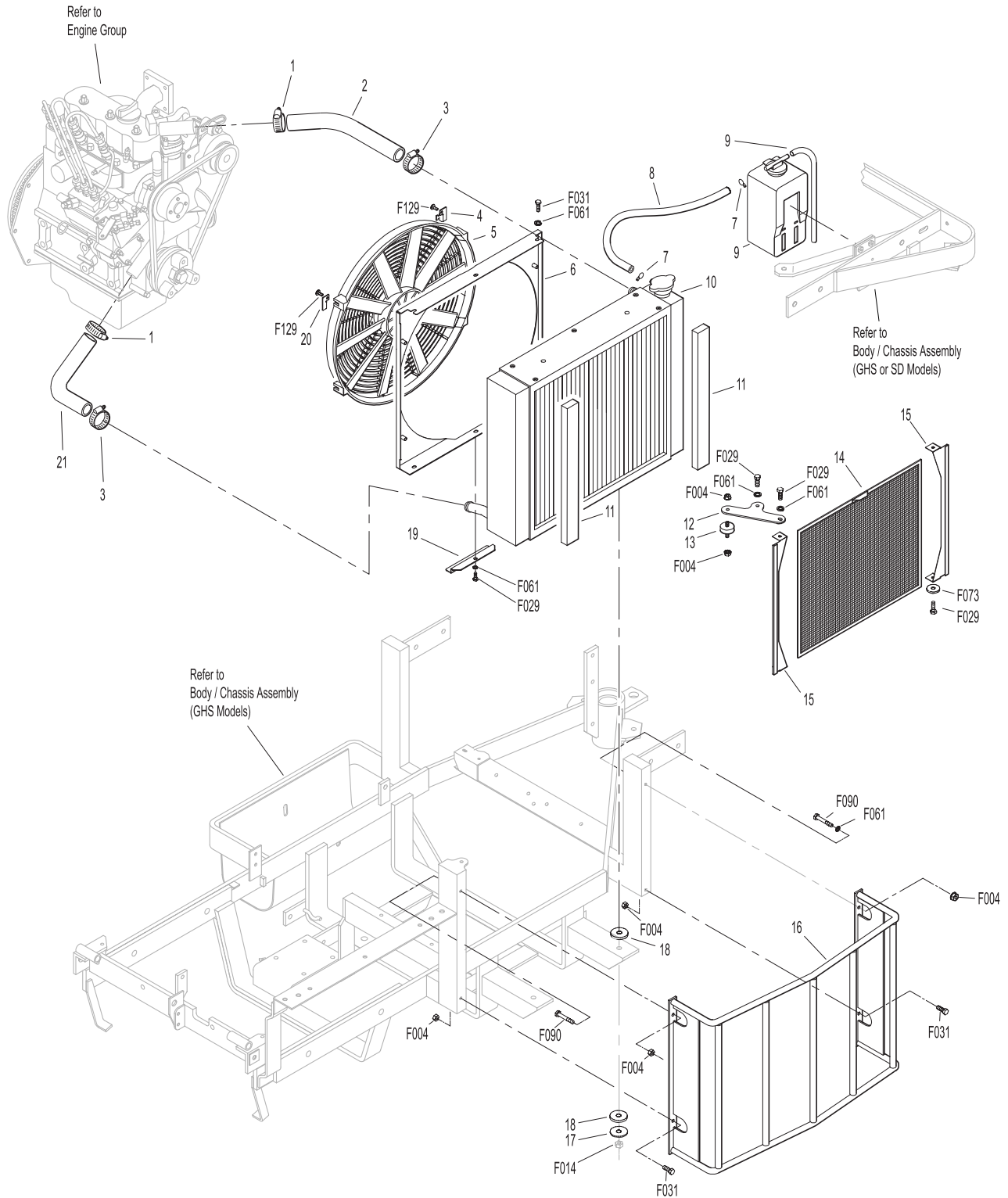

HYDROSTATIC GROUND DRIVE ASSEMBLIES

ITEM NO.	PART NO.	DESCRIPTION	NO. REQ'D	ITEM NO.	PART NO.	DESCRIPTION	NO. REQ'D
Transmission Lockout Assembly				Transmission Repair Parts			
1	5028-3	Transmission Lockout Assembly (Includes Items # 2-5, F023, F027 & F081)	*	25	5025-5	Input Shaft	*
2	5847	Plastic Tip	2	26	5025-8	Bearing, Input Shaft	*
3	5057	Lockout Cam (Includes Item # F081)	2	27	5025-7	Snap Ring	*
4	5028-5	Lockout Lever	2	28	5025-2	Seal, Input Shaft	*
5	5027-5	Lockout Mount	2	29	5022	Reservoir to Casting Gasket	*
Ground Drive Assemblies				30	5024	Reservoir Cap and Gasket	*
6	6209-1	Bridge Assembly	1	31	5023	Transmission Reservoir Kit	*
7	6243-1	Hydro Fan, CW	1	32	5023-1	Rubber Bladder	*
8	5025	Hydrostatic Drive, CCW (700-042)	1	33	5025-6	O-Ring & Plug Assembly	*
9	6206-1	Air Vent Valve	*	34	5025-3	Seal, Control Shaft	*
10	6200-9	Gear Axle Drive Assembly (Includes Item # 9)	2	Fasteners			
11	5126	Cable Retainer (Uses existing bolt on Gear Axle Drive Assembly)	1	F012	3/8-16 Keps Nut		1
12	6233-1	Pinion Gear	2	F023	10-24 ESNA Nut		2
13	6234	Spacer, Pinion Gear	2	F027	10-24 x 5/8 PPHMS		2
14	6201	O-Ring Seal	2	F036	1/4-20 x 1/2 SBH Screw		2
15	7244	Hydro Pulley (3-7/8) (Includes Items # F064 & F359)	2	F038	3/8-16 x 1 Hex Bolt		4
16	6243-2	Hydro Fan, CCW	1	F040	3/8-16 x 1-1/2 Hex Bolt		4
17	5026	Hydrostatic Drive, CW (700-041)	1	F043	3/8-16 x 3 Hex Bolt		7
Deck Support Arm Assemblies				F053	7/16 Internal Star Lock Washer		4
18	6430-10	Outboard Mount, LH	1	F063	3/8 Internal Star Lock Washer		16
19	6430-2	Deck Support Arm, LH (Includes Item # 23)	1	F064	1/8 x 1/2 Woodruff Key (#3)		6
20	5775-2	Hitch Pin (# 6)	2	F081	A/A45D Aluminum Pop Rivet		2
21	6430-1	Deck Support Arm, RH (Includes Item # 23)	1	F160	External Snap Ring (.669 Shaft)		2
22	6430-9	Outboard Mount, RH	1	F178	1/4 x 1 Fender Washer		2
23	5830	Grease Fitting	2	F194	7/16 x 1-1/4 x 1/8 Washer		2
24	6840-1	Support Arm Bushing (2-1/16)	2	F200	7/16-20 x 3 Grade 8 Bolt		2
				F244	7/16-20 x 3/4 Hex Bolt		2
				F262	3/8-16 x 4 Hex Bolt (Spec) All Thread		1
				F359	5/16-18 x 5/16 Set Screw (Unbrako Knurl Point)		4
				* Service Part Only			

Use only genuine Walker® replacement parts.

Effective Date 03-01-03

HYDROSTATIC GROUND DRIVE ASSEMBLIES

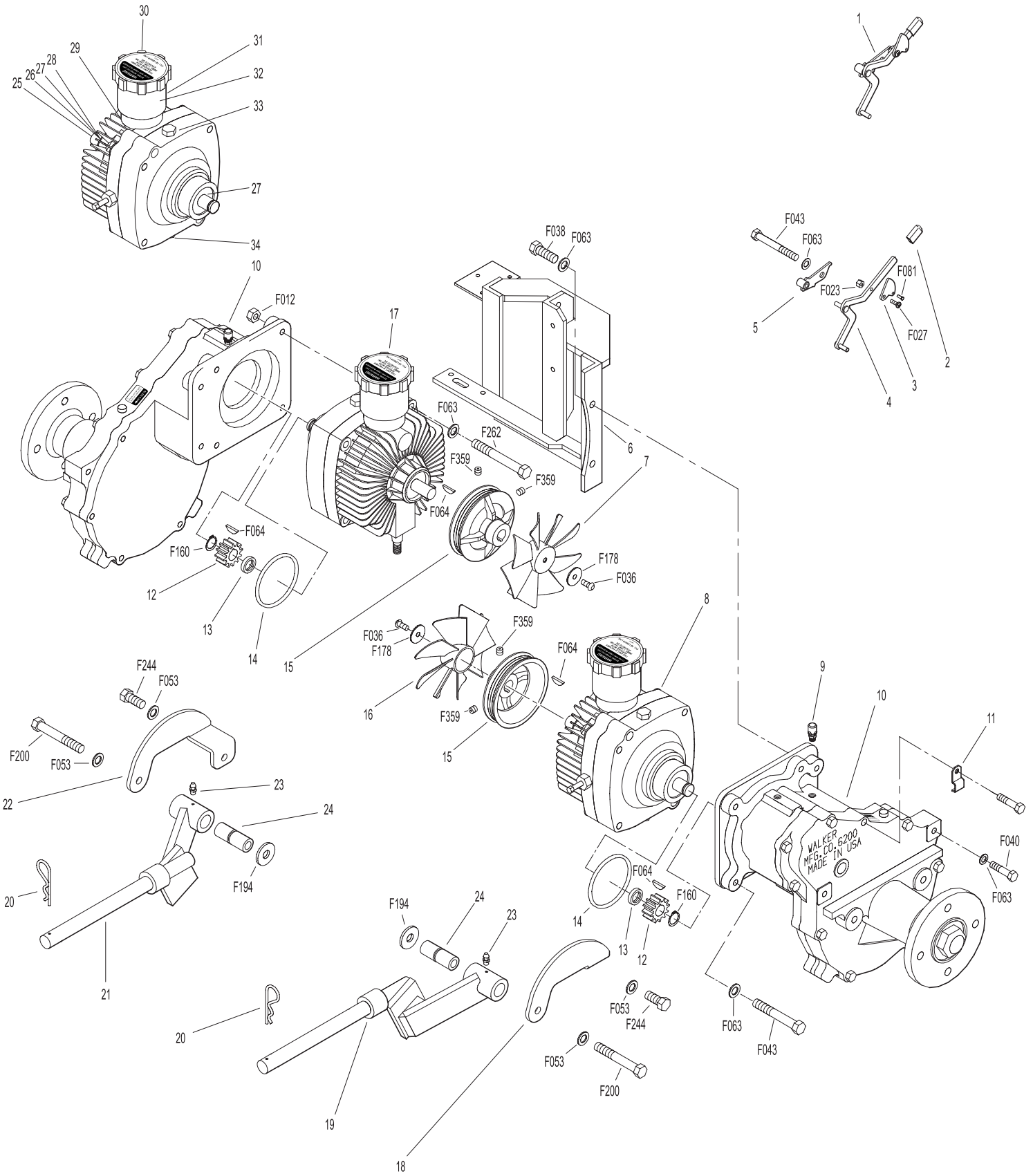

Effective Date 03-01-03

Use only genuine Walker® replacement parts.

STEERING CONTROL ASSEMBLIES

ITEM NO.	PART NO.	DESCRIPTION	NO. REQ'D	ITEM NO.	PART NO.	DESCRIPTION	NO. REQ'D	
Transmission Spring Assemblies				35	5450-3	Steering Lever Assembly, RH / Adj. (Includes Items # 16, 21, 36, F188, F198 & F345)	1	
1	6199	Transmission Spring Assembly (RH) (Includes Items # 2-8, F003, F287, F320 & F352)	*		5450-5	Steering Lever Arm, RH / Adj.	1	
2	5552	Ball Joint (1/4-28)	2	36	5453-10	Steering Lever Handle / Adj. (Includes Items # 21 & F345)	2	
3	5192-1	Spring Plunger	2	37	5862	FSC Knob	1	
4	5194	Plunger Sleeve	2	38	7170	FSC Lever Assembly (Includes Item # 16)	1	
5	6191	Spring Slide (4-3/4)	1	39	5975-3	Cable Tie (50# x 7")	1	
6	5195	Compression Spring (1 x 5-1/8)	2	40	5213-1	Control Rod, RH (15")	1	
7	6196	Spring Slide Cap	1	Fasteners				
8	5193	Washer (.750 ID x 1.00 OD x .085)	2		F003	1/4-28 Hex Nut	3	
9	5197	J-Bolt	1		F004	1/4-20 Keps Nut	8	
10	5191	Spring Slide (3-5/8)	1		F007	5/16-18 Jam Nut	1	
11	5199-10	Transmission Spring Assembly (LH) (Includes Items # 2-4, 6, 8-10, F003, F146, F287 & F352)	*		F008	5/16-24 Keps Nut	2	
Steering Lever & FSC Assemblies						F009	5/16-18 Whiz Locknut	1
12	5214-2	Ball Joint (5/16-24), Nylon Lined	2		F010	5/16-24 ESNA Nut	2	
13	5173	FSC Actuator Rod (Includes Items # 33 & F003)	1		F012	3/8-16 Keps Nut	2	
14	5172	Bearing, Nylon (.255 ID x .379 OD x .250)	1		F024	5/16-24 Jam Nut	2	
15	5142-2	FSC Actuator Cam	1		F029	1/4-20 x 1/2 Hex Bolt	2	
16	5830	Grease Fitting	6		F032	1/4-20 x 3/4 Hex Bolt	4	
17	6212	Transmission Control Arm, RH	1		F034	5/16-18 x 3/4 Hex Bolt	1	
18	5141	FSC Friction Washer	2		F050	1/4 SAE Washer	3	
19	5140-15	FSC Friction Body (Includes Item # 16)	1		F051	3/8 SAE Washer	2	
20	5142-7	FSC Key	1		F064	1/8 x 1/2 Woodruff Key (#3)	2	
	5140-13	FSC Control Assembly (Includes Items # 16, 18, 19, 20, F192 & F193)	*		F068	1/8 x 1 Cotter Pin	1	
21	5850-2	Handle Grip, Foam (5-1/2)	2		F069	3/32 x 1/2 Cotter Pin	1	
22	5212-5	Transmission Control Arm, LH	1		F093	5/16-18 x 1 Hex Bolt	1	
23	5213-2	Control Rod, LH (6")	1		F134	AN960816L Washer	3	
24	5223	Extension Spring (1/4 x 5-1/2)	2		F146	1/4-20 Jam Nut	1	
25	5450	D-Clip	2		F182	1/4 x 5/8 x 1/8 Washer	2	
26	5463	Steering Lever Actuator	2		F183	.312 x .700 x .074 Washer	2	
27	5214-1	Bearing, Steering Lever Actuator	2		F186	5/64 x 1/2 Cotter Pin	1	
28	5391-3	Steering Lever Support	1		F188	1/4-20 Self-Locking Nut	4	
29	5217	Pivot Pin, Steering Lever	1		F192	3/8-24 Self-Locking Nut	1	
30	5451-3	Steering Lever Assembly, LH / Adj. (Includes Items # 16, 21, 36, F188, F198 & F345)	1		F193	3/8 Belleville Spring Washer	3	
	5451-5	Steering Lever Arm, LH / Adj.	1		F198	.250 x .625 x .040 Washer, SS	4	
31	5219	FSC Extension Spring (3/4 x 6-3/4)	1		F287	1/4-28 Keps Nut	2	
32	5280	Clevis (1/4)	1		F320	1/8 x 3/4 Split Spring Pin	1	
33	5281-5	Clevis Pin (1/4 x 0.80)	1		F345	1/4-20 x .770 Knurled Bolt	4	
34	5470-1	Speed Control Stop	1		F352	5/32 x 1 Heavy Duty Roll Pin	2	
				*	Service Part Only			

Use only genuine **Walker**[®] replacement parts.

Effective Date 03-01-03

STEERING CONTROL ASSEMBLIES

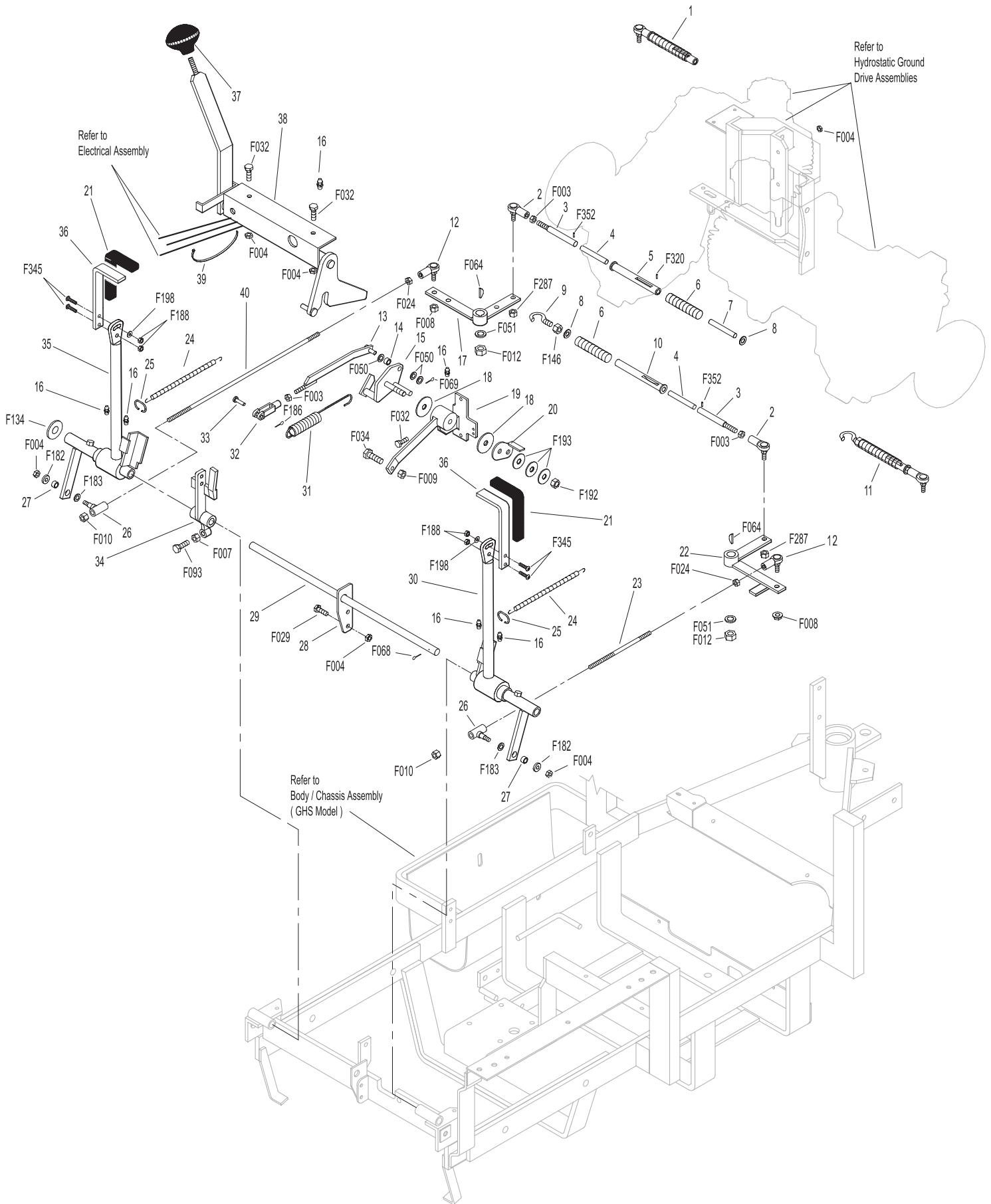

Effective Date 03-01-03

Use only genuine Walker® replacement parts.

THROTTLE CONTROL ASSEMBLIES

ITEM NO.	PART NO.	DESCRIPTION	NO. REQ'D	ITEM NO.	PART NO.	DESCRIPTION	NO. REQ'D
Throttle & Choke Control Assemblies				Fasteners			
1	5832	Cable Clamp (1/2)	2		F002	10-24 Keps Nut	4
2	7220	Throttle Cable	1		F005	1/4-20 ESNA Nut	1
3	NS	10-32 Jam Nut	2		F025	10-24 x 3/8 PPHMS	4
4	5150	Ball Joint (10-32)	2		F201	1/4 Belleville Spring Washer	2
5	5108-7	Control Lock Tab	1		F232	10-32 Keps Nut	2
6	5108-10	Friction Washer (.125)	1				
7	5108-1	Control Lever, Throttle	1	*		Service Part Only	
8	5108-5	Throttle Control Knob, Red	1				
9	5108-11	Friction Washer (.062)	1				
10	5108-8	Control Bracket (Diesel)	1				
11	7108	Control Assembly	*				
12	7112	Throttle Control and Cable Assembly (Complete Control and Cable Assembly)	*				

NOTE: Decals for this assembly are not shown here. Refer to **TRACTOR DECALS** (Page 2) for Decal listing and placement information.

THROTTLE CONTROL ASSEMBLIES

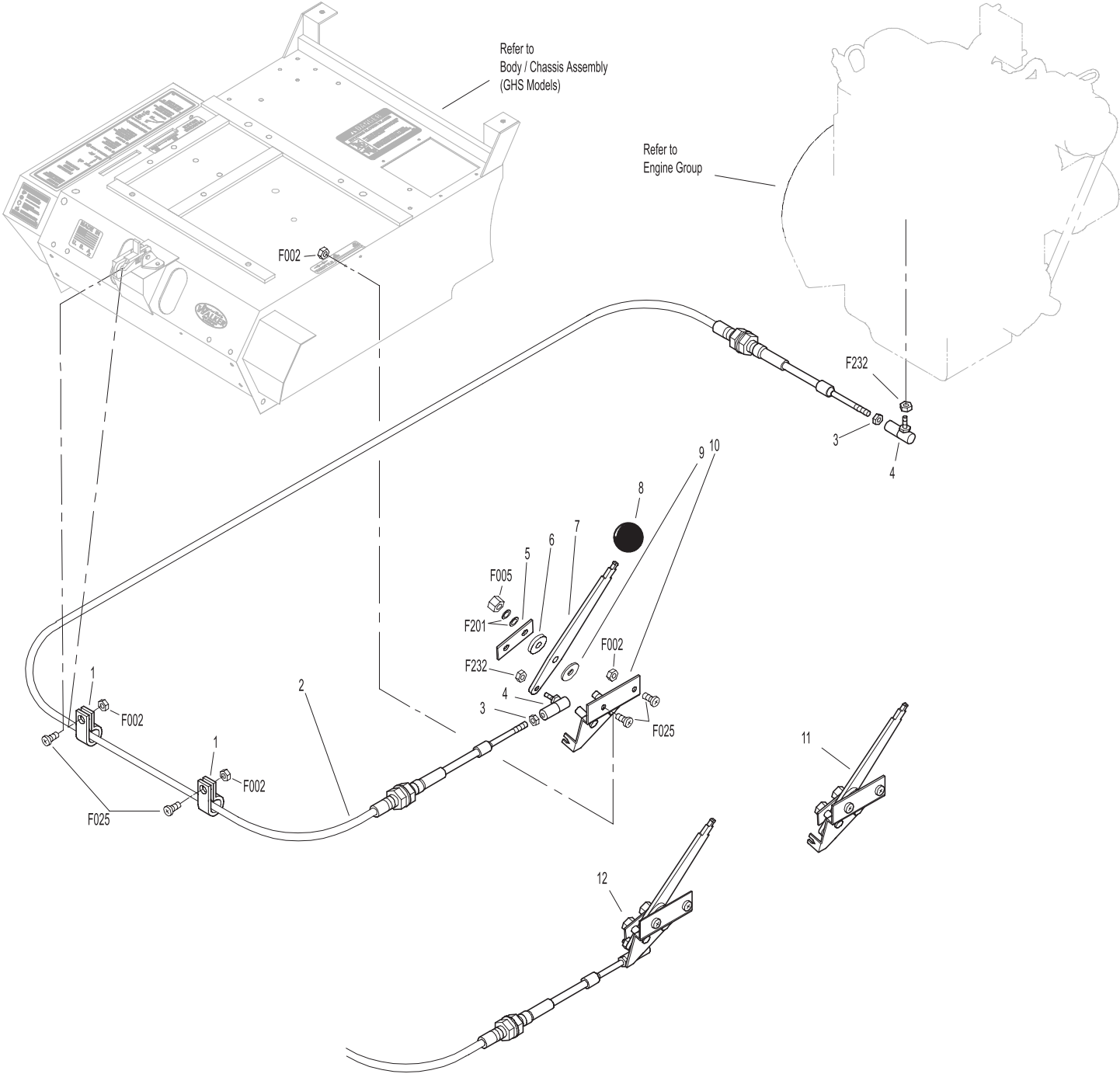

PARKING BRAKE ASSEMBLY

ITEM NO.	PART NO.	DESCRIPTION	NO. REQ'D	ITEM NO.	PART NO.	DESCRIPTION	NO. REQ'D
Parking Brake Assembly				Fasteners			
1	7406-1	Handle Grip, Red	1	F002		10-24 Keps Nut	2
2	7406-8	Parking Brake Lever	1	F003		1/4-28 Hex Nut	1
3	7406-2	Lever Mount	1	F004		1/4-20 Keps Nut	4
4	5830	Grease Fitting	1	F025		10-24 x 3/8 PPHMS	2
5	7407	Clevis Pin (3/16 x 1/2)	2	F029		1/4-20 x 1/2 Hex Bolt	3
6	7404	Brake Actuator Arm	2	F032		1/4-20 x 3/4 Hex Bolt	1
7	7405	Pin, Transmission Lock	2	F054		AN960616 Washer	1
8	7402	Clevis	2	F072		1/4 "E" Retainer Ring	2
9	7408	Compression Spring (1/2 x 3/4)	2	F086		#10 SAE Washer	4
10	7415	Rubber Dust Shield (5/8 x 3/8 x 1/32)	2	F109		1/8 x 5/8 Roll Pin	2
11	5567-3	O-Ring Seal (1/4 x 3/8)	4	F111		1/8 x 3/4 Cotter Pin	1
12	7403	Plunger Bushing, Gear Axle	2	F112		5/8 x 1-1/4 x .03 Washer	2
13	7404-1	Brake Actuator Mount	2	F127		1/16 x 1/2 Cotter Pin	4
14	7412	Clevis Pin (3/16 x 5/8)	2	F261		AN960616L Washer	6
15	5833	Cable Clamp (1/4)	2	F287		1/4-28 Keps Nut	1
16	7410	Brake Control Cable, LH (27")	1				
17	7409	Brake Control Cable, RH (21")	1				
18	7401-3	Cable Mount Bracket	1				
19	7401-1	Cable Pull Rod	1				
20	5552	Ball Joint (1/4-28)	1				

PARKING BRAKE ASSEMBLY

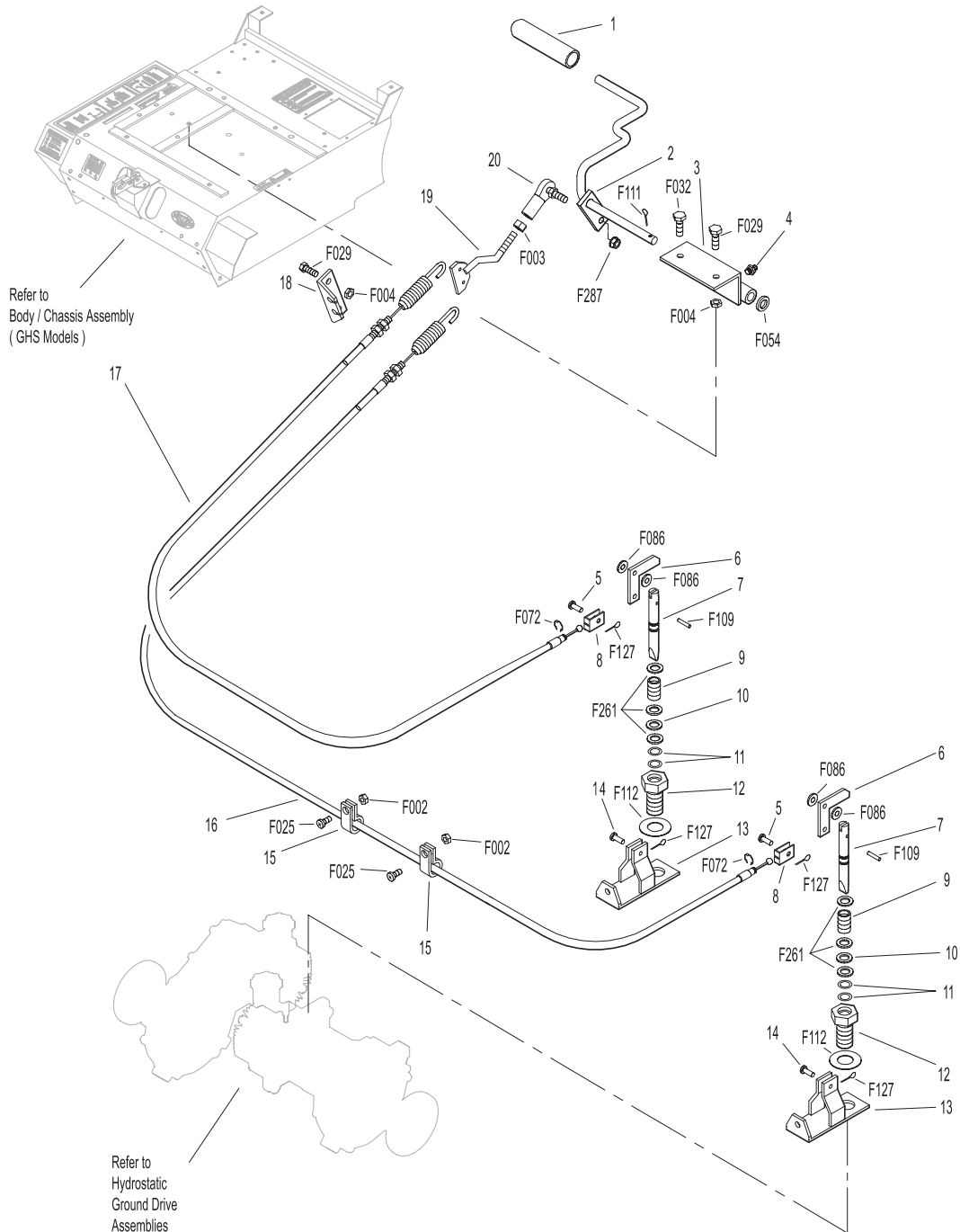

GHS GROUP

ITEM NO.	PART NO.	DESCRIPTION	NO. REQ'D
----------	----------	-------------	-----------

Delivery Chute Assembly

When Optional 9.5 Bushel Catcher Assembly is purchased, Item # 6 is replaced by P/N 8511-1 (Delivery Chute Assembly, 9.5).

1	5515-2	Elbow Delivery Spout	1
2	5592-13	Backing Plate, Grass-Pak® Switch	1
3	5592-12	Mount Plate, Grass-Pak® Switch	1
4	5578	Rear Clip, Chute Mount	1
5	5577	Side Clip, Chute Mount	2
6	7511-1	Delivery Chute with Clips, 7.0 (Includes Items # 4, 5, 7, F079 & F085)	1♦
	8511-1	Delivery Chute with Clips, 9.5 (Includes Items # 4, 5, 7, F079 & F085)	*
7	5578-10	Front Clip, Chute Mount	1
8	7530-3	Body Chute	1

Blower Belt Tightener Assembly

9	7238-1	Blower Drive Pulley (Mirco-V)	1
10	7234-1	Blower Belt (Micro-V)	1
11	7239-1	Blower Pulley (Mirco-V)	1
12	7364-2	Torsion Spring	1
13	5830-3	Grease Fitting (45 Deg.)	1
14	7364-1	Blower Belt Tightener Arm	1
15	7201-4	Inner Race (1-1/2)	1
16	7201-3	DU Bearing	1
17	5841	Retainer Washer	1
18	5245	Idler Pulley (3")	1

Blower Assembly

19	5268	Bearing (3/4) with Collar	2
20	6543	Housing (10" Blower)	1
	6542	Blower Assembly (10")	*
21	6545	Blower Wheel (10")	1
22	6525-2	Faceplate (10" Blower)	1
23	6526	Intake Tube (6-1/2 x 2-1/2)	1
24	5595-2	Intake Cover	**
25	7528	Skid Bar (10" Blower)	1
26	7833	Cable Clamp (7/8 x 1/4)	1

ITEM NO.	PART NO.	DESCRIPTION	NO. REQ'D
----------	----------	-------------	-----------

Fasteners

F002	10-24 Keps Nut	8
F004	1/4-20 Keps Nut	6
F009	5/16-18 Whiz Locknut	1
F012	3/8-16 Keps Nut	3
F025	10-24 x 3/8 PPHMS	2
F026	10-24 x 1/4 PPHMS	2
F034	5/16-18 x 3/4 Hex Bolt	1
F038	3/8-16 x 1 Hex Bolt	1
F040	3/8-16 x 1-1/2 Hex Bolt	1
F042	3/8-16 x 2-1/4 Hex Bolt	1
F054	AN960616 Washer	1
F067	3/16 x 3/16 x 1 Key	1
F074	1/4-20 x 3/8 Set Screw	2
F075	5/16-18 x 1/2 SQH Set Screw	1
F079	A/A66D Aluminum Pop Rivet	6
F085	3/16 Rivet Backup Washer	6
F102	10-24 x 1-1/2 PTHMS	2
F114	5/16-18 x 5/8 SQH Set Screw	2
F128	10-24 x 3/8 PTHMS	4
F163	5/16-18 x 3/4 SQH Set Screw	1
F217	7/16-14 Hex Nut	1
F218	7/16 Split Lock Washer	1
F219	7/16-14 x 1-1/4 Hex Bolt	1
F231	1/4 x 3/4 Woodruff Key (# 806)	1
F362	A/A62D Alum. Pop Rivet (3/16D x 13/32L)	2

* Service Part Only

** Plugs Blower when GHS is not in use. Furnished only with Mulching Decks, SD Decks used on a GHS Tractor, Rotary Broom Attachment and Snowblower Attachment.

♦ For use on GHS 7.0 Bushel Catcher Assembly. When Optional 9.5 Bushel Catcher Assembly is purchased, this part is replaced by P/N 8511-1 (Delivery Chute Assembly, 9.5). Refer to Optional **GHS 9.5 BUSHEL CATCHER ASSEMBLY** (Page 34).

NOTE: Refer to **ELECTRICAL CONNECTORS** (Page 42) for identification of all Electrical Wiring Service Parts.

GHS GROUP

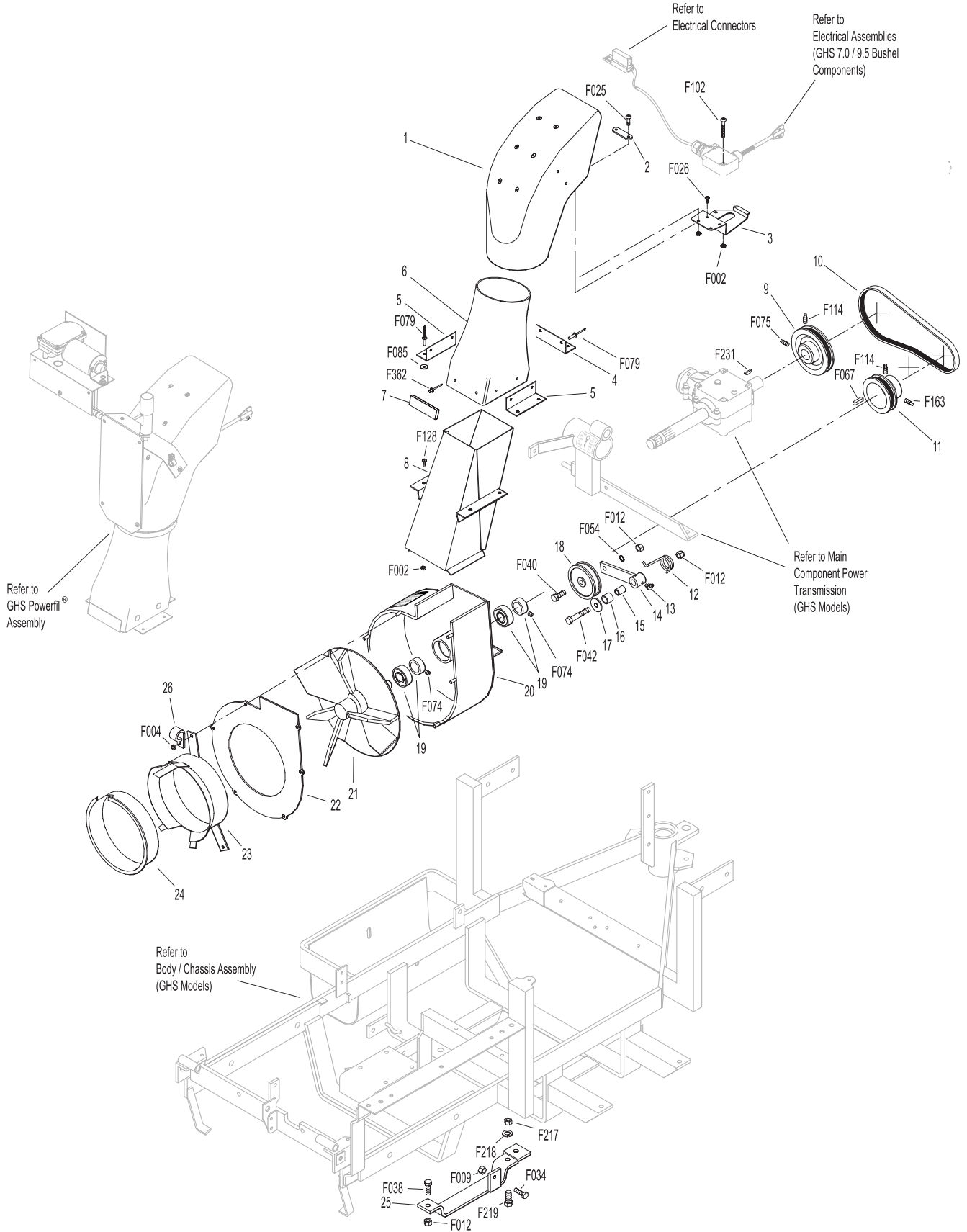

GHS POWERFIL® ASSEMBLY

ITEM NO.	PART NO.	DESCRIPTION	NO. REQ'D	ITEM NO.	PART NO.	DESCRIPTION	NO. REQ'D
GHS Powerfil® Assembly				Fasteners			
1	5557	Motor Mount, Powerfil®	1	F002		10-24 Keps Nut	14
2	5551-3	Bearing Cap, Powerfil®	1	F003		1/4-28 Hex Nut	3
3	5551-1	Pivot Bearing (#S3PP)	2	F025		10-24 x 3/8 PPHMS	2
4	5552	Ball Joint (1/4-28)	2	F054		AN960616 Washer	1
5	5518-2	Pivot, Delivery Spout	1	F085		3/16 Rivet Backup Washer	1
6	5517-2	Pivot Mount	1	F101		10-24 x 1-1/4 SHC Screw	1
7	5558-1	Powerfil® Push Rod	1	F109		1/8 x 5/8 Roll Pin	1
8	5553-3	Bushing, Powerfil® Actuator	4	F129		10-24 x 1/2 PTHMS	10
9	5558-2	Powerfil® Actuator Rod	1	F261		AN960616L Washer	1
	5549	Actuator Rod Assembly (Includes Items # 4, 7-10, & F003)	*	F287		1/4-28 Keps Nut	1
10	5553-1	Spring, Powerfil® Actuator	2	* Service Part Only			
11	5554	Actuator Arm	1				
12	5519-3	Motor Mount Nut (5/8-24 Panel Nut)	*				
13	5519-2	Motor Mount Washer	*				
14	5519	Actuator Motor (12/24V) (Includes Items # 12 & 13)	1				
15	5977	Grommet (1/2 ID x 7/8 OD x 1/16)	1				

Use only genuine **Walker®** replacement parts.

Effective Date 03-01-03

GHS POWERFIL[®] ASSEMBLY

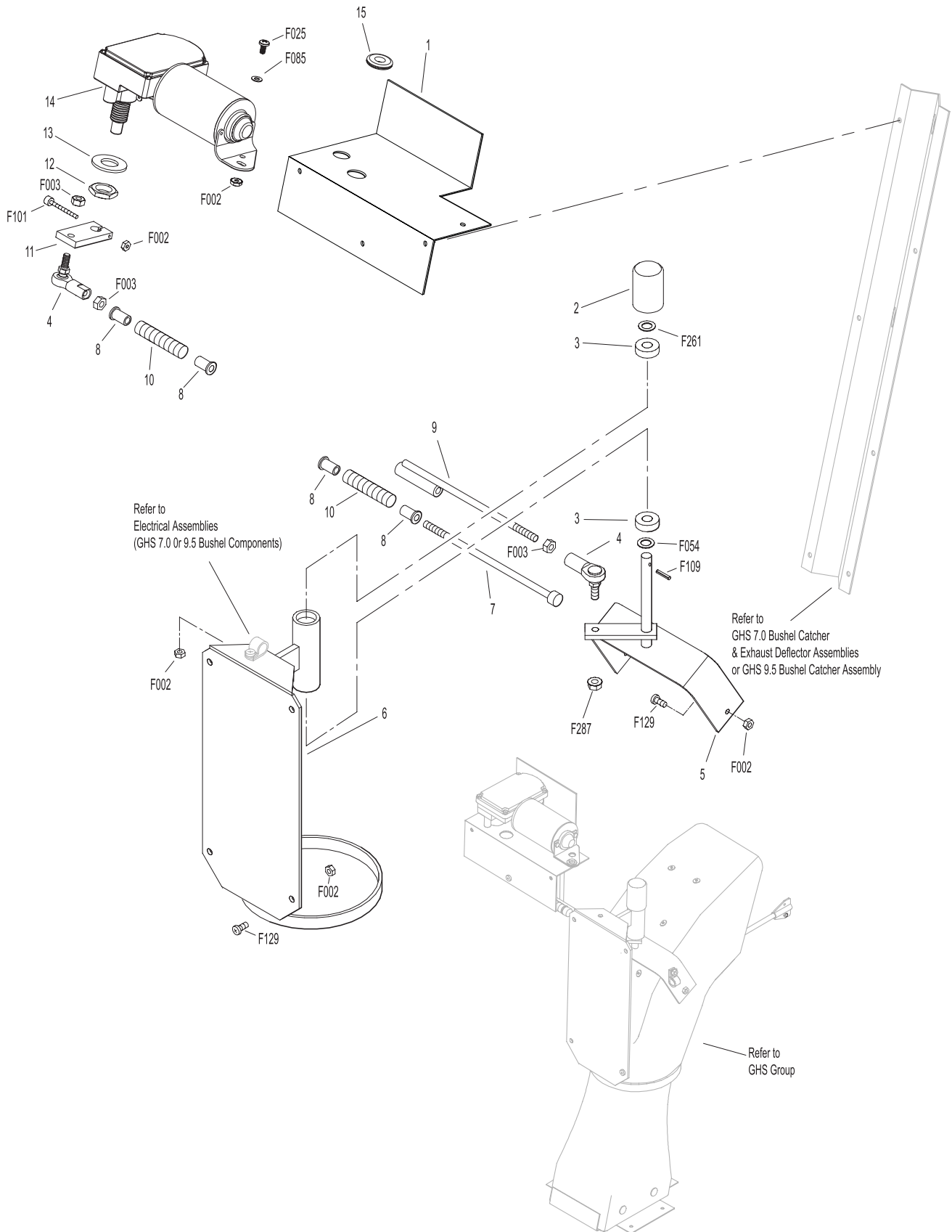

GHS 7.0 BUSHEL CATCHER & EXHAUST DEFLECTOR ASSEMBLIES

ITEM NO.	PART NO.	DESCRIPTION	NO. REQ'D	ITEM NO.	PART NO.	DESCRIPTION	NO. REQ'D
Upper Baffle Screen Assembly (Removable)				35	5976	Grommet (3/8 ID x 11/16 OD)	1
1	7509-3	Channel Bottom	2	36	5976-2	Grommet (3/16 ID x 3/4 OD)	1
2	7505	Mustache Spring	2	37	5522-2	Hinge Backup Plate, RH	1
3	7507	Screen Seal, (27-1/2)	1	38	7508	7.0 / 9.5 Safety Latch Hinge	1
4	7856-1	Edge Molding, (26")	1	39	7584	Reinforcing Strap, Catcher Top	2
5	7509-2	Channel Top	2	40	7514-1	Backup Plate, Catcher Door	1
6	7512-2	Removable Screen, 3/16 Holes / Standard	1	5598 Optional Dump Bag (Not Shown)			
	7512-3	Removable Screen, 3/4 Holes / Optional		May be ordered as an option. Contact your Walker dealer. Not used with Power Dump Option.			
7	7506	Knob	2	Fasteners			
8	7509-4	C-Channel, 7.0 / 9.5	1	F002	10-24 Keps Nut		27
Exhaust Deflector Assembly				F004	1/4-20 Keps Nut		16
9	7504-3	Hinge, Exhaust Deflector	1	F009	5/16-18 Whiz Locknut		2
10	7504-1	Exhaust Deflector (Two Piece Set)	1	F020	5/16-18 ESNA Nut		2
	7504	Exhaust Deflector Kit, 7.0 / 9.5	*	F025	10-24 x 3/8 PPHMS		4
11	7504-8	Deflector Mount Doubler	2	F026	10-24 x 1/2 PPHMS		8
GHS 7.0 Bushel Catcher Assembly				F027	10-24 x 5/8 PPHMS		4
12	5583	Handle	1	F035	5/16-18 x 1-1/4 Hex Bolt		1
13	5588	Rubber Bumper (.75 OD x .50)	2	F037	10-24 x 5/8 PTH Screw		2
14	7522	Side Strap, Door (7.0)	2	F049	5/16 SAE Washer		4
15	7610	Catcher Dump Plate	1**	F061	1/4 Internal Star Lock Washer		2
16	7610-1	Dump Plate Slide	2**	F069	3/32 x 1/2 Cotter Pin		2
17	7513-2	Mounting Frame Doubler, 7.0	1	F079	A/A66D Aluminum Pop Rivet		18
18	5281-5	Clevis Pin (1/4 x 0.80)	2**	F085	3/16 Rivet Backup Washer		15
19	7503	Mounting Frame, Catcher (7.0)	1	F129	10-24 x 1/2 PTHMS		14
20	5522-1	Hinge Backup Plate, LH	1	F137	3/8-16 x 1/2 x 2 SHL Bolt		2
21	7503-9	Pivot Bushing (5/16 x 5/8)	2	F172	1/4-20x3/4 Carriage Bolt		4
22	7510-1	7.0 Bushel Catcher, Including Door	1	F188	1/4-20 Self Locking Nut		18
	7502-1	7.0 Catcher Assembly, Without Powerfil®	*	F195	1/4-20 x 3/4 PPHMS SS		8
		(Includes Door)		F196	1/4-20 x 1 PPHMS SS		3
	7502-2	7.0 Catcher Assembly (With Powerfil®)	*	F198	.625 x .250 x .040 Washer, SS		5
23	7514-10	7.0 Door Frame, Catcher	1	F228	# 6 x 1/2 PPHSM Set Screw		2
24	5155-12	5/16 Ball Stud	2	F230	1/4-20 x 1-1/4 PPHMS SS		1
25	5147	Spring Clip, Gas Spring	4	F242	1/4-20 x 7/8 PPHMS SS		11
26	5155-2	Gas Spring Cover	2	F252	10-24 x 3/4 PPHMS		1
27	5155	Catcher Door Gas Spring Assembly	2	F255	5/16-18 x 1-1/2 Hex Bolt		1
		(Includes Items # 24, 25 & 29)		F329	.260 ID x 1.939 OD Washer		2
28	5524-1	Flanged Hinge Bearing	2	F330	3/16 D x 21/32 Rivet, SS		2
29	5155-13	3/4 Ball Stud	2	F340	Rivet, Aluminum		4
30	5523-6	Gas Spring Plate	2	F351	Aluminum Pop Rivet		6
31	7532	Handle, Catcher Lift	2	* Service Part Only			
	7534	Catcher Handle Kit	*				
		(Includes Items # 31, 32, F004 & F172)		** Existing Part on units with Serial Number 94-16484 and on. Earlier Models require installation of Dump Plate Kit 7611.			
32	7533	Backing Plate, Handle	2				
33	5155-15	Box Support, Gas Spring	2				
34	7557-10	7.0 Wire Harness Channel	1				

Use only genuine **Walker®** replacement parts.

Effective Date 03-01-03

GHS 7.0 BUSHEL CATCHER & EXHAUST DEFLECTOR ASSEMBLIES

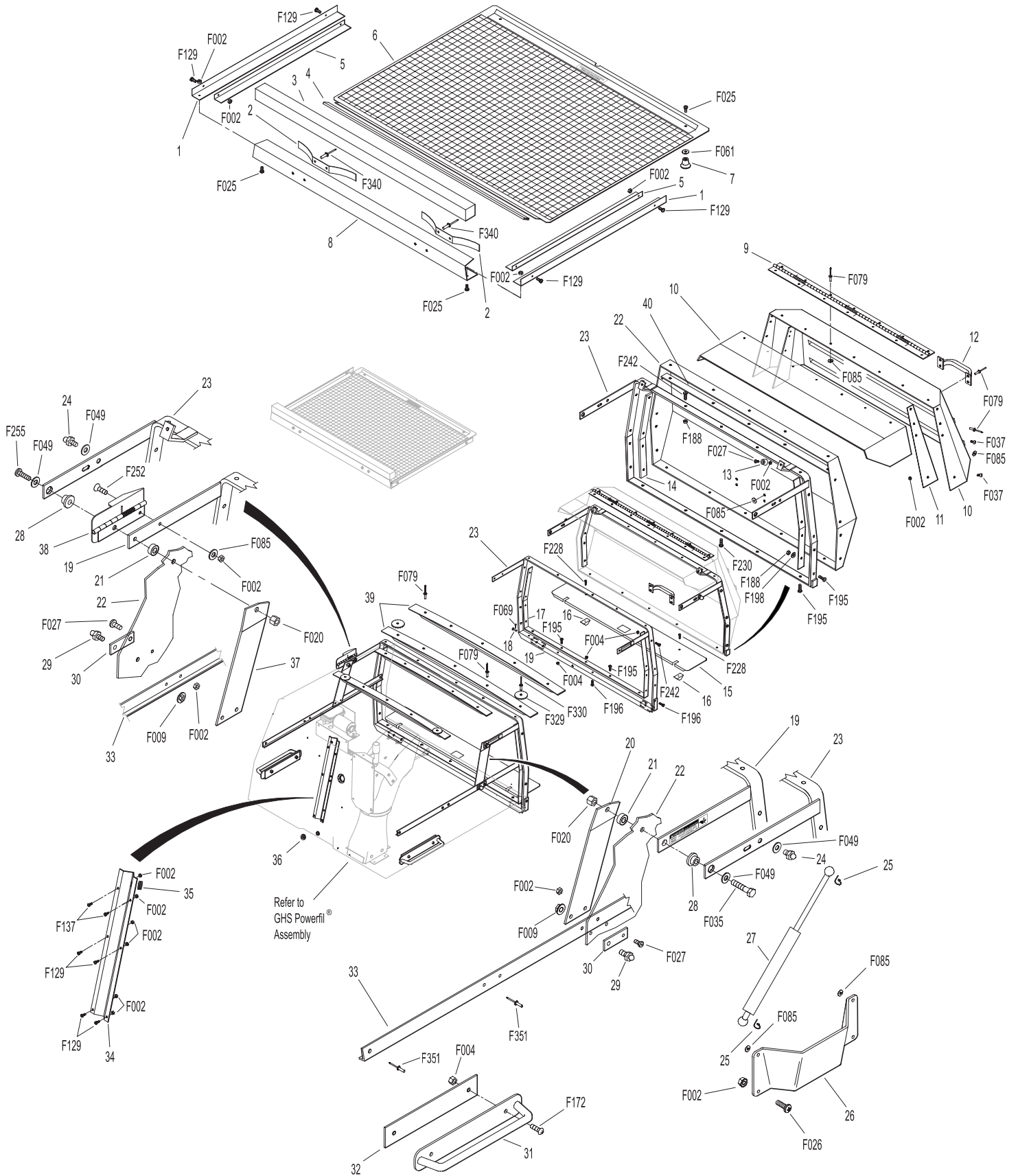

Effective Date 03-01-03

Use only genuine Walker® replacement parts.

GHS 9.5 BUSHEL CATCHER ASSEMBLY

ITEM NO.	PART NO.	DESCRIPTION	NO. REQ'D	ITEM NO.	PART NO.	DESCRIPTION	NO. REQ'D
GHS 9.5 Bushel Catcher Assembly				Fasteners			
May be ordered as a factory-installed option. Contact your Walker dealer.							
1	8514-11	9.5 Door Frame, Catcher	1	F002		10-24 Keps Nut	21
2	8510-1	9.5 Bushel Catcher, Including Door	1	F004		1/4-20 Keps Nut	22
	8502-1	9.5 Catcher Assembly, Without Powerfil® (Includes Door)	*	F009		5/16-18 Whiz Locknut	2
	8502-2	9.5 Catcher Assembly (Includes Powerfil®)	*	F020		5/16-18 ESNA Nut	2
3	7514-1	Backup Plate, Catcher Door	1	F026		10-24 x 1/2 PPHMS	8
4	5588	Rubber Bumper (.75 OD x .50)	2	F027		10-24 x 5/8 PPHMS	4
5	8516	Side Strap, Door / 9.5	2	F035		5/16-18 x 1-1/4 Hex Bolt	1
6	5583	Handle	1	F037		10-24 x 5/8 PTH Screw	2
7	5522-1	Hinge Backup Plate, LH	1	F049		5/16 SAE Washer	4
8	7503-9	Pivot Bushing (5/16 x 5/8)	2	F069		3/32 x 1/2 Cotter Pin	2
9	8503-2	Mounting Frame, Catcher (9.5)	1	F079		A/A66D Aluminum Pop Rivet	18
10	5155-12	5/16 Ball Stud	2	F085		3/16 Rivet Backup Washer	15
11	5147	Spring Clip, Gas Spring	4	F129		10-24 x 1/2 PTHMS	4
12	5155	Gas Spring Assembly, Catcher Door (Includes Items # 10, 11, & 15)	2	F172		1/4-20 x 3/4 Carriage Bolt	4
13	5155-2	Gas Spring Cover	2	F188		1/4-20 Self Locking Nut	20
14	5524-1	Flanged Hinge Bearing	2	F195		1/4-20 x 3/4 PPHMS SS	8
15	5155-13	3/4 Ball Stud	2	F196		1/4-20 x 1 PPHMS SS	3
16	5523-6	Gas Spring Plate	2	F198		.625 x .250 x .040 Washer, SS	5
17	7533	Backing Plate, Handle	2	F230		1/4-20 x 1-1/4 PPHMS SS	1
18	7532	Handle, Catcher Lift	2	F242		1/4-20 x 7/8 PPHMS SS	15
19	5155-15	Box Support, Gas Spring	2	F252		10-24 x 3/4 PFHMS	1
20	8117	9.5 Wire Harness Channel	1	F255		5/16-18 x 1-1/2 Hex Bolt	1
21	5976	Grommet (3/8 ID x 11/16 OD)	2	F329		.260 ID x 1.939 OD Washer	2
22	5522-2	Hinge Backup Plate, RH	1	F330		3/16 D x 21/32 L Rivet, SS	2
23	7508	Safety Latch Hinge, 7.0 / 9.5	1	F351		Aluminum Pop Rivet	6
24	7584	Reinforcing Strap, Catcher Top	2				
25	5281-5	Clevis Pin (1/4 x .080)	2				
26	8513-3	9.5 Mounting Frame Doubler	1				

* Service Part Only

NOTE: Refer to **ELECTRICAL CONNECTORS**, Page 42 for identification of all Electrical Wiring Service Parts.

GHS 9.5 BUSHEL CATCHER ASSEMBLY

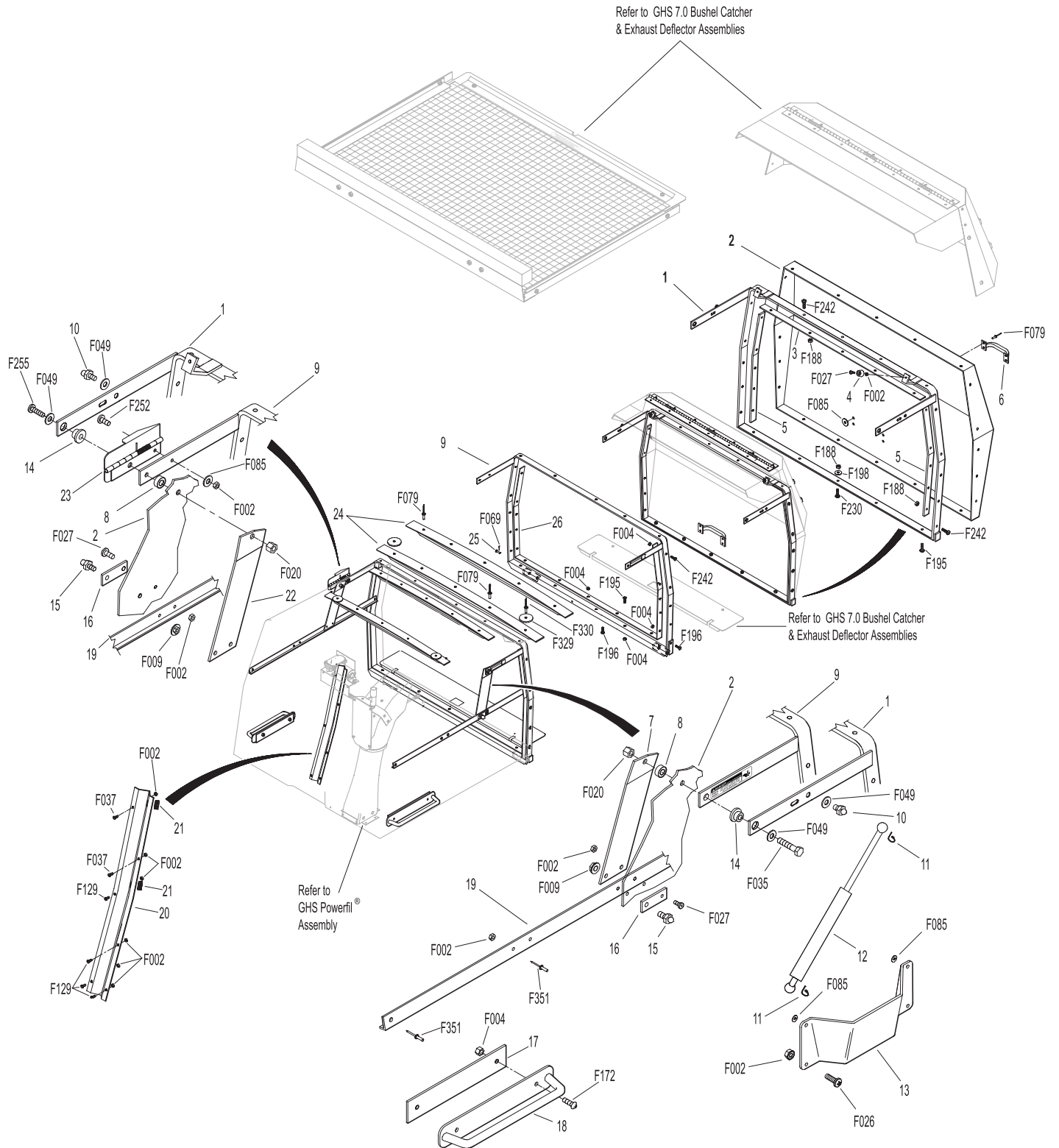

INSTRUMENT PANEL ASSEMBLY

ITEM NO.	PART NO.	DESCRIPTION	NO. REQ'D	ITEM NO.	PART NO.	DESCRIPTION	NO. REQ'D
Instrument Panel Assembly				20	8996-3	Indicator Bulb (Replacement for P/N 8996-2)	*
1	7307-2	Instrument Panel Cover (Optional)	**	21	7307-1	Shock Mount (1.0 OD x .25)	3
	7396-1	Instrument Panel Assembly MDD (Includes Items # 2-20, F228, F250 & F251)	1	22	7391	Panel Box Mount Plate	2
2	7307	Panel Frame	1	23	7385-1	Panel Box	1
3	7823-4	Decal, Instrument Panel	1	24	7977-1	Grommet (1/8 x 1-1/16)	1
4	7307-6	Panel Faceplate	1	25	7307-16	Foam Insert, Panel Box	1
5	7386	Panel Gasket	1	26	8536	Warning Horn	1
6	7960-6	Ignition Key (1 Set)	*	27	6941	Relay Switch (30/40 Amp)	1
7	7960-5	Ignition Switch (with Keys) (Includes Item # 20)	1	Fasteners			
8	8996-2	Red Indicator Light Assembly (Includes Items # 19 & 20)	2		F002	10-24 Keps Nut	1
9	7941-3	Boot, Circuit Breaker	2		F004	1/4-20 Keps Nut	6
10	7941-1	Circuit Breaker (5 Amp)	1		F025	10-24 x 3/8 PPHMS	1
11	7941-2	Circuit Breaker (10 Amp)	1		F228	#6 x 5/8 PPH SMS, SS	8
12	8990-1	Hourmeter (SenDec)	1		F238	J Clip, Instrument Panel C15520-6A	8
13	5995	Toggle Switch (Off-On)	1		F250	6-32 x 3/8 PPHMS	2
14	5995-2	Switch Boot (Fits P/N 5995)	1		F251	6-32 Keps Nut	2
15	7306-3	Water Temperature Gauge	1	* Service Part Only			
16	8997	Voltmeter Gauge	1	** May be ordered as an option. Contact your Walker dealer.			
17	7947-3	Wire Harness, Instrument Panel	1	NOTE: Refer to ELECTRICAL CONNECTORS , Page 42 for identification of all Electrical Wiring Service Parts.			
18	5975-1	Cable Tie (18# x 3-3/4")	2				
19	8996-4	Red Indicator Lens	2				

INSTRUMENT PANEL ASSEMBLY

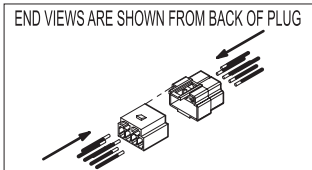
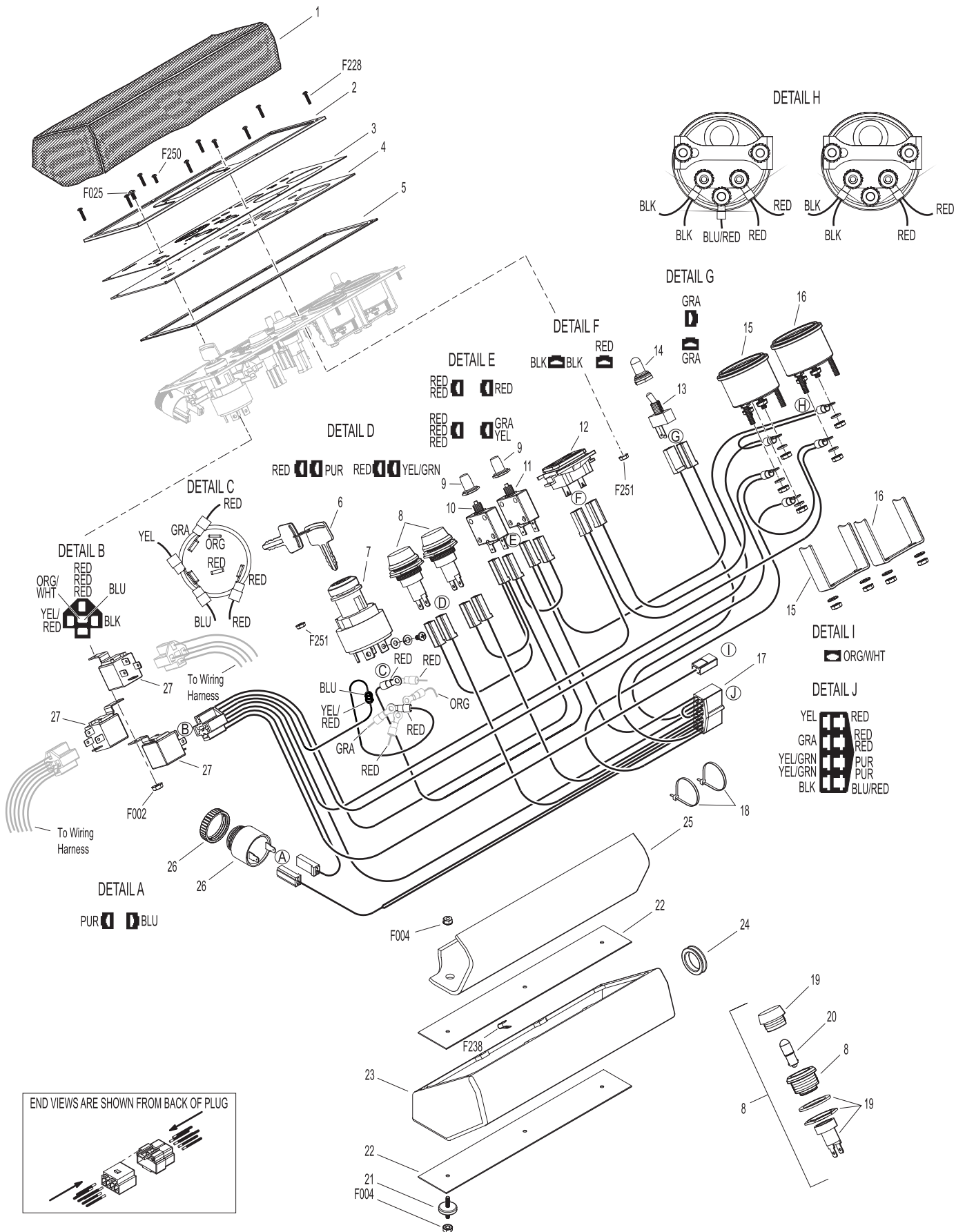

Effective Date 03-01-03

Use only genuine Walker® replacement parts.

ELECTRICAL ASSEMBLY

ITEM NO.	PART NO.	DESCRIPTION	NO. REQ'D	ITEM NO.	PART NO.	DESCRIPTION	NO. REQ'D
Battery Assembly						(Auto Reset/Sealed)	
1	5975-1	Cable Tie (18# x 3-3/4")	3	35	7940-5	Circuit Breaker Jumper	1
2	5933	Battery Terminal Insul., Red (+)	1	Fasteners			
3	5844	Battery Hold-Down Bar	1	F002	10-24 Keps Nut		8
4	5839	Hook Bolt, Battery Mount	2	F004	1/4-20 Keps Nut		6
5	6392	Battery Protector Plate	1	F009	5/16-18 Whiz Locknut		1
6	7390-1	Battery Pan	1	F019	1/4-20 ESNA Wing Nut		2
7	7910	Battery (12V U1-SP30, Dry)	1	F025	10-24 x 3/8 PPHMS		3
8	5932	Battery Terminal Insul., Black (-)	1	F026	10-24 x 1/2 PPHMS		2
9	6923	Negative Battery Cable	1	F027	10-24 x 5/8 PPHMS		3
Harness Assembly				F031	1/4-20 x 5/8 Hex Bolt		2
10	5975-3	Cable Tie (50# x 7") (GHS Models Use Only 3)	4	F032	1/4-20 x 3/4 Hex Bolt		3
11	5833	Cable Clamp (1/4)	1	F050	1/4 SAE Washer		3
12	5942-4	PTO Safety Switch (Normal Open)	1	F061	1/4 Internal Star Lock Washer		1
13	7940-9	Wire Harness	1	F079	A/A66D Aluminum Pop Rivet		5
14	5832	Cable Clamp (1/2)	5	F078	A/A64D Aluminum Pop Rivet		2
15	7944	7.0 Wire Harness	1*	F085	3/16 Rivet Backup Washer		1
	8950	9.5 Wire Harness	1*	F090	1/4-20 x 2-1/2 Hex Bolt		1
16	7938	Lead Wire (Battery Charge)	1	F093	5/16-18 x 1 Hex Bolt		1
17	7306-10	Switch (235 Deg., 1/4-18 NPT)	1	F116	1/4-20 x 1-1/4 Hex Bolt		1
18	7306-11	Switch (205 Deg., 3/8-18 NPT)	1	F129	10-24 x 1/2 PTHMS		1
19	6941	Relay Switch 30/40 Amp	1	F182	5/8 x 1/4 x 1/8 Washer		1
20	7433	Resistor, Ceramic / .4 OHM	1	F188	1/4-20 Self Locking Nut		1
21	7833	Cable Clamp (7/8 x 1/4)	2	* Service Part Only			
22	7948-2	Time Delay Harness	1	** GHS Models Only			
23	7948-1	Time Delay Module	1	*** Used on GHS Models with 7.0 Bushel Catcher only. When Optional GHS 9.5 Bushel Catcher is purchased, this part is replaced by P/N 8950 (9.5 Catcher Wire Harness). Refer to Optional GHS 9.5 BUSHEL CATCHER ASSEMBLY (Page 34).			
24	7672	Mount Bracket	1	NOTE: Refer to ELECTRICAL CONNECTORS (Page 42) for identifi- cation of all Electrical Wiring Service Parts.			
25	7428-1	Fan Control Module	1	NOTE: Item # 12 is a Service Part used exclusively on GHS Models.			
26	5942-5	Safety Switch (Normal Open)	1	NOTE: Decals for this assembly are not shown here. Refer to TRACTOR DECALS (Page 2) for Decal listing and place- ment information.			
27	5941-5	Safety Switch (Normal Open)	1				
28	7203-6	Riser Plate, Seat Switch	1				
29	5977-6	Grommet (1 x 1-1/4)	1				
30	5975-5	Wire Clip, Self-Mount	1				
31	7943	Positive Battery Lead Wire (Red)	1				
32	8941	Circuit Breaker (30 Amp) (Auto Reset/Sealed)	1				
33	7857-10	Breaker, Mount Bracket	1				
34	7941	Circuit Breaker (40 Amp)	1				

ELECTRICAL ASSEMBLY

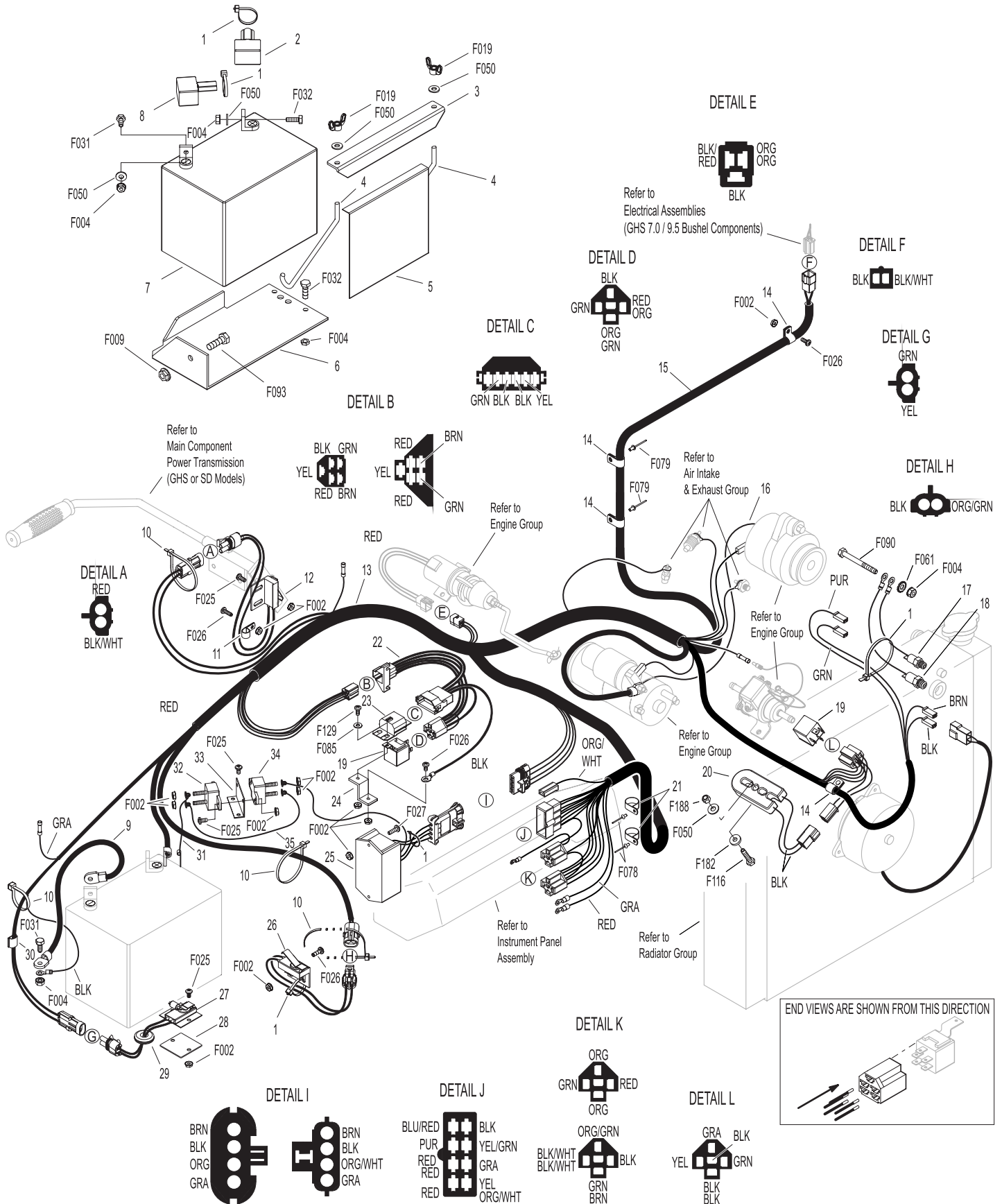

Effective Date 03-01-03

Use only genuine Walker® replacement parts.

ELECTRICAL ASSEMBLIES (GHS 7.0 / 9.5 BUSHEL COMPONENTS)

ITEM NO.	PART NO.	DESCRIPTION	NO. REQ'D	ITEM NO.	PART NO.	DESCRIPTION	NO. REQ'D
Horn & Harness Channel Assemblies				Fasteners			
1	5599	Pigtail Wire Set, Horn	1	F002		10-24 Keps Nut	5
2	5975-3	Cable Tie (50# x 7")	2	F025		10-24 x 3/8 PPHMS	1
3	5536-2	Horn, Full Signal	*	F037		10-24 x 5/8 PTH Screw	1
Harness & Grass-Pak® Switch Assemblies				F079		A/A66D Aluminum Pop Rivet	4
4	7835	Frame Clip (3/16)	2	F085		3/16 Rivet Backup Washer	4
5	7834	Nylon Clamp (1/4)	4	F129		10-24 x 1/2 PTHMS	6
6	8950	Wire Harness, 9.5 Catcher	1	F137		3/8-16 x 1/2 x 2 SHL Bolt	1
	7944	Wire Harness, 7.0 Catcher		F144		4-40 x 1/4 PPHMS	1
7	5833	Cable Clamp (1/4)	2	F145		4-40 Keps Nut	1
8	5980-3	Wire, Grass-Pak® Switch	1	* Service Part Only			
9	5592-11	Liquid Tight Plug	1	NOTE: Refer to ELECTRICAL CONNECTORS , Page 42 for identification of all Electrical Wiring Service Parts.			
10	5592-10	Grass-Pak® Switch Module	1				
	5592-4	Grass-Pak® Switch Assembly (Includes Items # 3, 9 & 10-13)	*				
11	5594-5	Vane Assembly, Grass-Pak® Switch (Includes Items # F144 & F145)	1				
12	5977-2	Grommet, Cut (1/8 x 3/8)	1				

ELECTRICAL ASSEMBLIES (GHS 7.0 / 9.5 BUSHEL COMPONENTS)

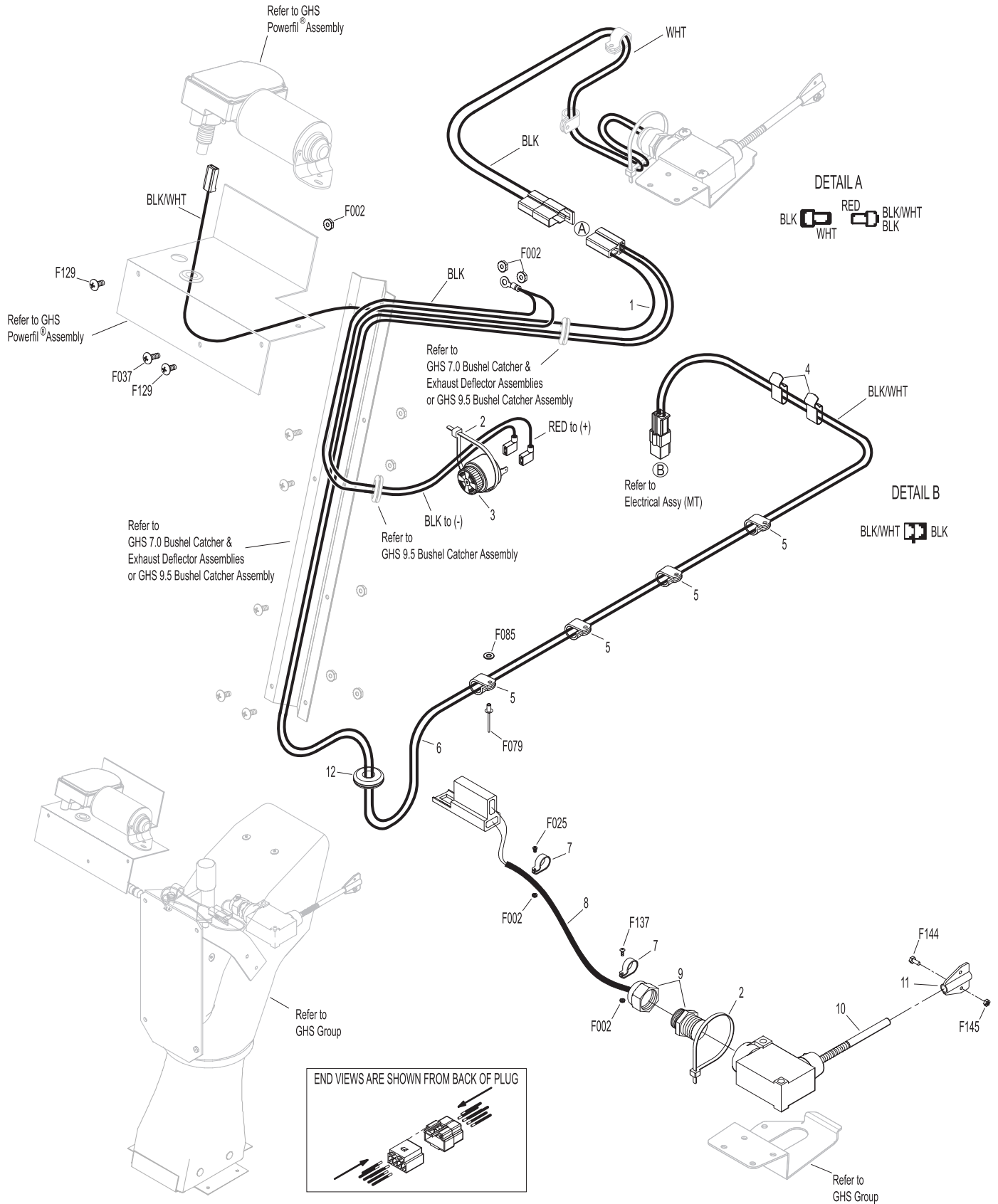

Effective Date 03-01-03

Use only genuine **Walker**® replacement parts.

ELECTRICAL CONNECTORS

ITEM NO.	PART NO.	DESCRIPTION	NO. REQ'D	ITEM NO.	PART NO.	DESCRIPTION	NO. REQ'D
Electrical Wiring Service Parts				29	7942-1	2-Way Locking Connector, Female	*
1	5996-1	16-14 GA Butt Connector	*	30	7942-2	2-Way Connector, Male	*
2	5996-11	12-10 GA Butt Connector	*	31	7942-3	2-Way Connector, Female	*
3	7942-14	14-16 GA Shrink Connector	*	32	7942-10	2-Way Locking Connector, Male	*
4	7942-13	10-12 GA Shrink Connector	*	33	5940-8	3-Way Connector, Male	*
5	5995-1	Wire Terminal Adapter	*	34	7942-9	3-Way Connector, Male	*
6	5996-4	16-14 GA Bullet Conn., Male	*	35	8944	3-Way Locking Connector, Male	*
7	5996-5	16-14 GA Bullet Conn., Female	*	36	8944-1	3-Way Locking Connector, Female	*
8	5940-4	16-14 GA Spg. Loaded Term., Female	*	37	7942-11	4-Way Connector, Male	*
9	5940-7	Brass Wire Clip, Female	*	38	7942-12	4-Way Connector, Female	*
10	5996	1/4 x 16-14 GA QKS Term., Female	*	39	7942-5	5-Way Connector, Male	*
11	5996-2	3/16 x 22-18 GA QKS Term., Female	*	40	5940-2	5-Way Connector, Male	*
12	7996	3/16 x 16-14 GA QKS Term., Female	*	41	8942-1	5-Way Connector, Female	*
13	5940-5	16-14 GA Spg. Loaded Term., Male	*	42	7942-6	6-Way Connector, Male	*
14	5996-0	1/4 x 22-18 GA QKS Term., Male	*	43	7942-7	6-Way Connector, Male	*
15	5996-18	16-14 GA Ring Term. (#8) Nylon Insulated	*	44	7942-8	8-Way Connector, Male	*
16	7996-1	1/4 x 16-14 GA QKS Term., Male	*	45	8942-2	8-Way Connector, Female	*
17	5996-8	6 GA Ring Lug (5/16)	*	46	8942-3	5-Way Connector, Male	*
18	5996-9	22-18 GA Ring Term., #10	*	47	5940-9	3-Way Connector (M)	*
19	5996-10	16-14 GA Ring Term. (5/16)	*	48	7942-15	6-Way Connector (Female)	*
20	5996-12	12-10 GA Ring Term. (5/16)	*	49	7940-3	Packard Plug (Male)	*
21	5996-13	16-14 GA Ring Term., # 10	*	50	7940-4	Packard Plug (Female)	*
22	5996-15	12-10 GA Ring Term. (1/2)	*				
23	5996-16	6 GA Ring Terminal (1/4)	*				
24	5996-17	16-14 GA Ring Term. (1/4)	*				
25	5996-20	12-10 GA Ring Term. (1/4)	*				
26	5996-21	12-10 GA Ring Term., #10	*				
27	7942-4	Single Connector, Male	*				
28	8942	2-Way Connector, Male	*				

* Service Part Only

NOTE: Not all Electrical Connectors are used with all assemblies.

NOTE: Refer to **ELECTRICAL ASSEMBLY**, Page 38 for locations of Wiring Harness and of all Electrical Wiring Service Parts.

ELECTRICAL CONNECTORS

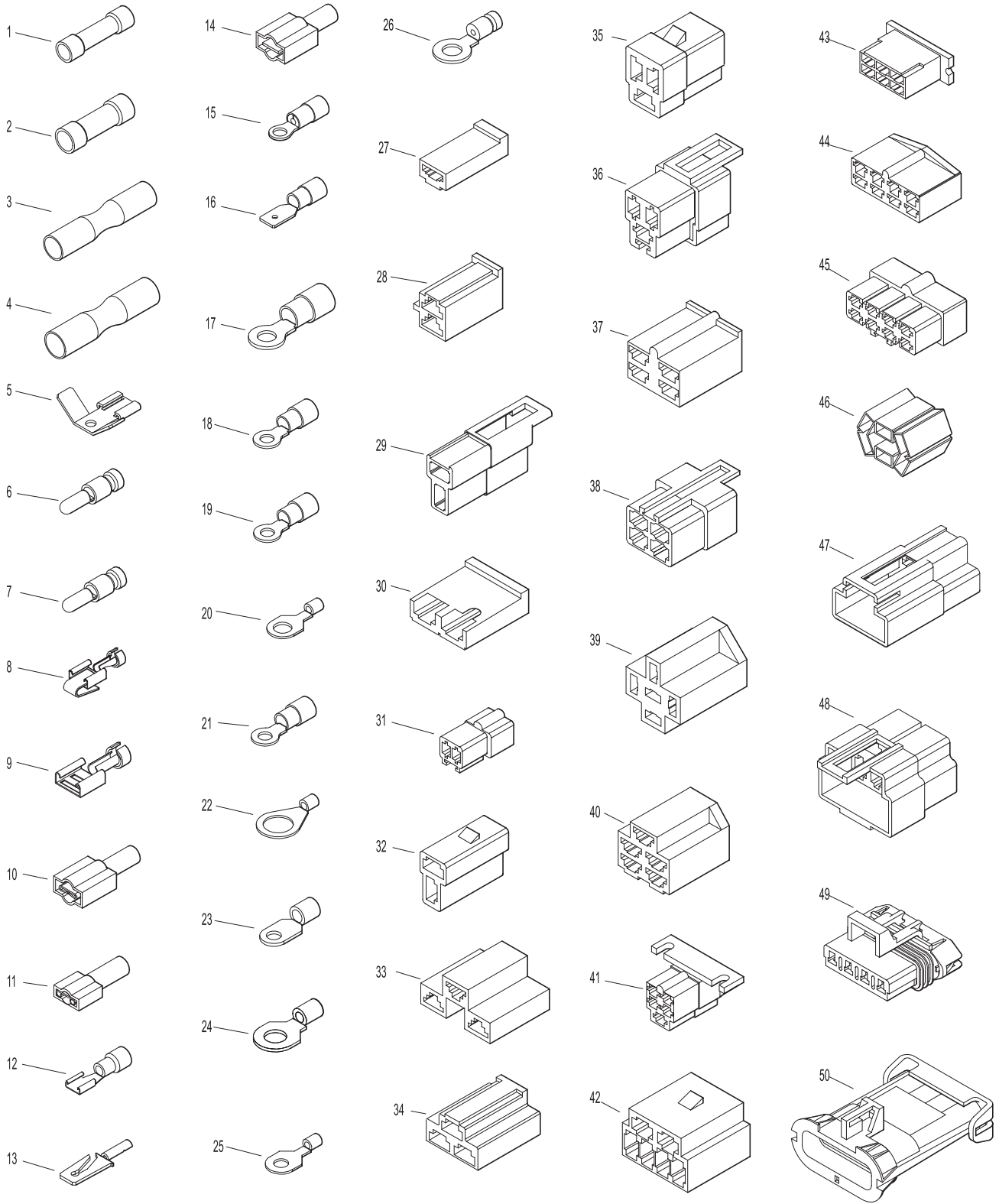

POWER DECK LIFT KIT

ITEM NO.	PART NO.	DESCRIPTION	NO. REQ'D	ITEM NO.	PART NO.	DESCRIPTION	NO. REQ'D
Kit 8655 Power Deck Lift Option / Kit Includes Items # 1-30, fasteners listed and instructions. May be ordered as a dealer-installed option. Contact your Walker dealer.				Fasteners			
1	8628	Linear Actuator, Deck	1	F002		10-24 Keps Nut	1
2	8655-8	Clamp Bar	1	F004		1/4-20 Keps Nut	14
3	7503-10	Actuator Drive Bushing	1	F009		5/16-18 Whiz Locknut	6
4	8655-11	Bushing (5/8 OD x 5/16 x 1-1/16)	1	F025		10-24 x 3/8 PPHMS	1
5	8655-10	Bushing (5/8 OD x 5/16 x 1-1/16)	1	F029		1/4-20 x 1/2 Hex Bolt	8
6	8655-7	Arm, Deck Lift	1	F050		1/4 SAE Washer	1
7	8655-9	Cable Pull	1	F061		1/4 Star Lock Washer	1
8	8655-12	Bushing (3/4 OD x 1/4 ID x 3/4)	1	F068		1/8 x 1 Cotter Pin	1
9	5977-1	Grommet (1/8 x 3/8)	1	F069		3/32 x 1/2 Cotter Pin	2
10	8649	Wire Harness, Deck Lift	1	F093		5/16-18 x 1 Hex Bolt	2
11	5975-5	Wire Clip, Self Mount	1	F134		AN960816L Washer	1
12	6623	Toggle Switch	1	F179		1/4-20 x 1 Hex Bolt	1
13	5996-21	12-10 GA Ring Terminal (# 10)	*	F316		5/16-18 x 1-3/4 Hex Bolt	2
14	8655-1	Hitch Pin / Cotterless (5/8)	2	F320		1/8 x 3/4 Split Spring Pin	*
15	8655-6	Lift Chain	2	* Service Part Only			
16	8655-5	Cable Mount	2	NOTE: Power Deck Lift is not compatible with Comfort Seat or Suspension Seat.			
17	5996-20	12-10 GA Ring Terminal (1/4)	*				
18	8942-3	Five-Way Connector (M)	*				
19	5940-4	16-14 GA Spring-Loaded Terminal (F)	*				
20	8655-3	Cable, LH (48")	1				
21	8655-2	Cable, RH (38.5")	1				
22	8654	Decal, Deck Lift	1				
23	6623-1	Switch Boot	1				
24	6832	Cable Clamp (9/16 x 1/4)	1				
25	5832	Cable Clamp (1/2)	1				
26	8655-22	Base, Deck Lift	1				
27	8655-4	Clevis Pin (5/16 x 3/4)	2				
28	5975-3	Cable Tie (#50 x 7")	3				
29	7942-1	Two-Way Locking Connector (F)	*				
30	5940-5	16-14 GA Spring-Loaded Terminal (M)	*				

POWER DECK LIFT KIT

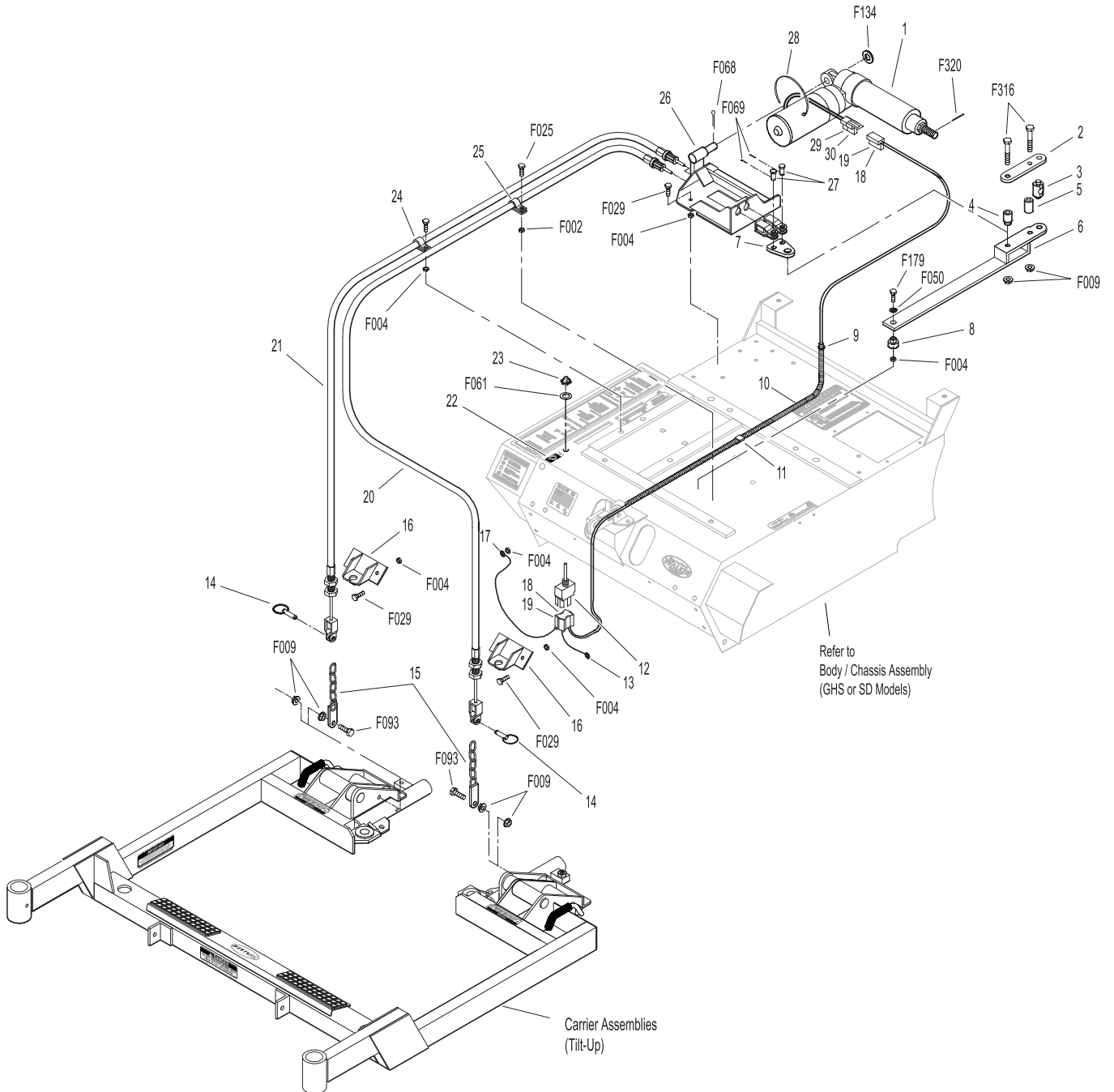

ARMREST KIT / TOUCH-UP PAINT

ITEM NO.	PART NO.	DESCRIPTION	NO. REQ'D	ITEM NO.	PART NO.	DESCRIPTION	NO. REQ'D
Kit 5885 Armrest Option / Kit				Touch-Up Paint			
Includes Items # 1-5, fasteners listed and instructions. May be ordered as a dealer-installed option. Contact your Walker dealer.				6	5866	Touch-Up Paint, Yellow (12 oz. Aerosol)	
1	5886-1	Armrest, RH	1	7	5867	Touch-Up Paint, Grey (12 oz. Aerosol)	
2	5886-3	Cover Plate, RH	1	8	5873	Touch-Up Paint, Grey (1 qt.)	
3	5887	Mounting Bracket	1	Fasteners			
4	5886-4	Cover Plate, LH	1	F305	1/4-20 x 3/8 SH Cap Screw		2
5	5886-2	Armrest, LH	1	F306	3/8-16 x 3/4 Hex Bolt		4
	5888	Armrest Hardware Kit	*	F307	#10 x 5/8 PPHST Screw		2
		(Includes Items # F305, F306, F307 & F308)		F308	1-1/4 x 1-5/8 Wave Spring Washer		2

* Service Part Only

ARMREST KIT / TOUCH-UP PAINT

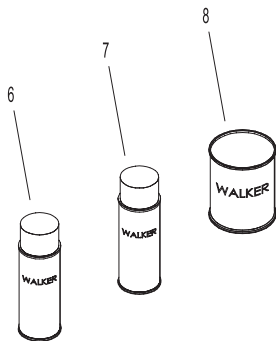
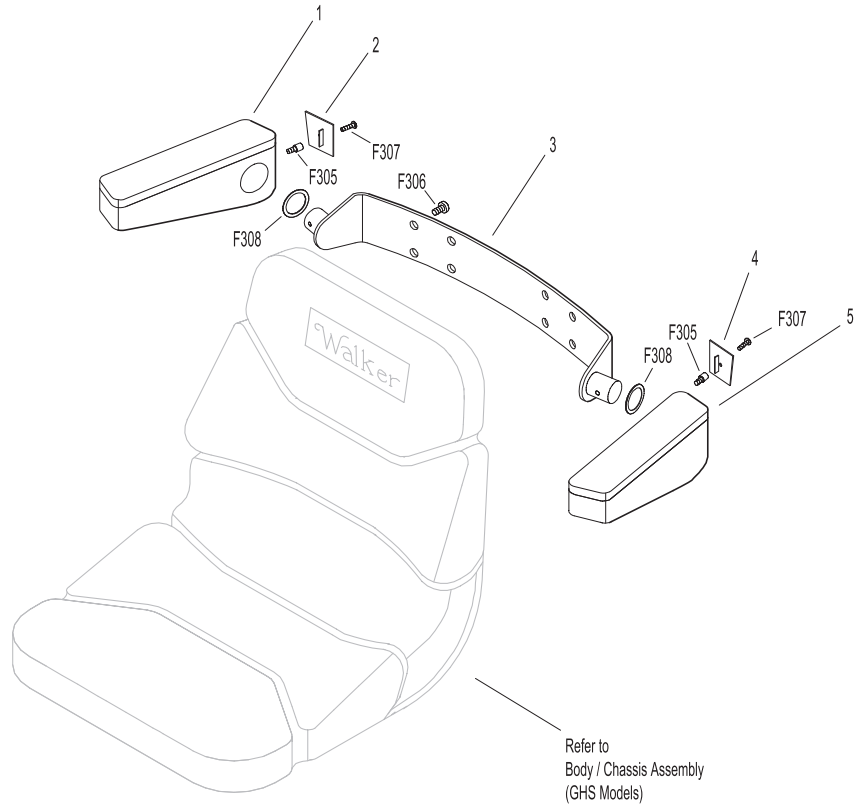

COMFORT SEAT / ARMREST KIT

ITEM NO.	PART NO.	DESCRIPTION	NO. REQ'D
----------	----------	-------------	-----------

Kit 6103-5 Comfort Seat Kit (Grey)

Includes Items # 1, 6, fasteners listed and instructions. May be ordered as a dealer-installed option. Contact your Walker dealer.

1	6103-5	Comfort Seat	1
2	7203	Seat Spring Plate	*
3	7223	Compression Spring (1/2 x 1)	*
4	7846	Rubber Washer (3/8 ID x 1-1/4 OD x 1/8)	*
5	7204	Shoulder Bolt, Seat Mount	*
6	7203-6	Riser Plate, Seat Switch	**
7	7845	Rubber Bumper (1.375 OD x .63)	*
8	7440-5	Shock Mount (1.25 D x .75)	*

Kit 6103-15 Armrest Option / Kit

Includes Items # 9, 10 and instructions. Item # 9 is the **Right** side armrest only. Item # 10 is the **Left** side armrest only. Sold only as a complete set and may be ordered together as a factory-installed option or as a kit for dealer installation. Contact your Walker dealer.

9	6103-42	Armrest, Right Side	1
10	6103-41	Armrest, Left Side	1

ITEM NO.	PART NO.	DESCRIPTION	NO. REQ'D
----------	----------	-------------	-----------

Fasteners

F009	5/16 - 18 Whiz Locknut	*
F026	10-24 x 1/2 PPHMS	2
F227	3/8-1-1/4 x 1/8 Plastic Washer	*

* Reuse existing parts from Seat Assembly. Refer to **BODY / CHASSIS ASSEMBLY (GHS MODELS)**, Page 4.

** Only one Riser Plate is included with kit. One is reused from Seat Assembly. Refer to **BODY / CHASSIS ASSEMBLY (GHS MODELS)**, Page 4.

COMFORT SEAT / ARMREST KIT

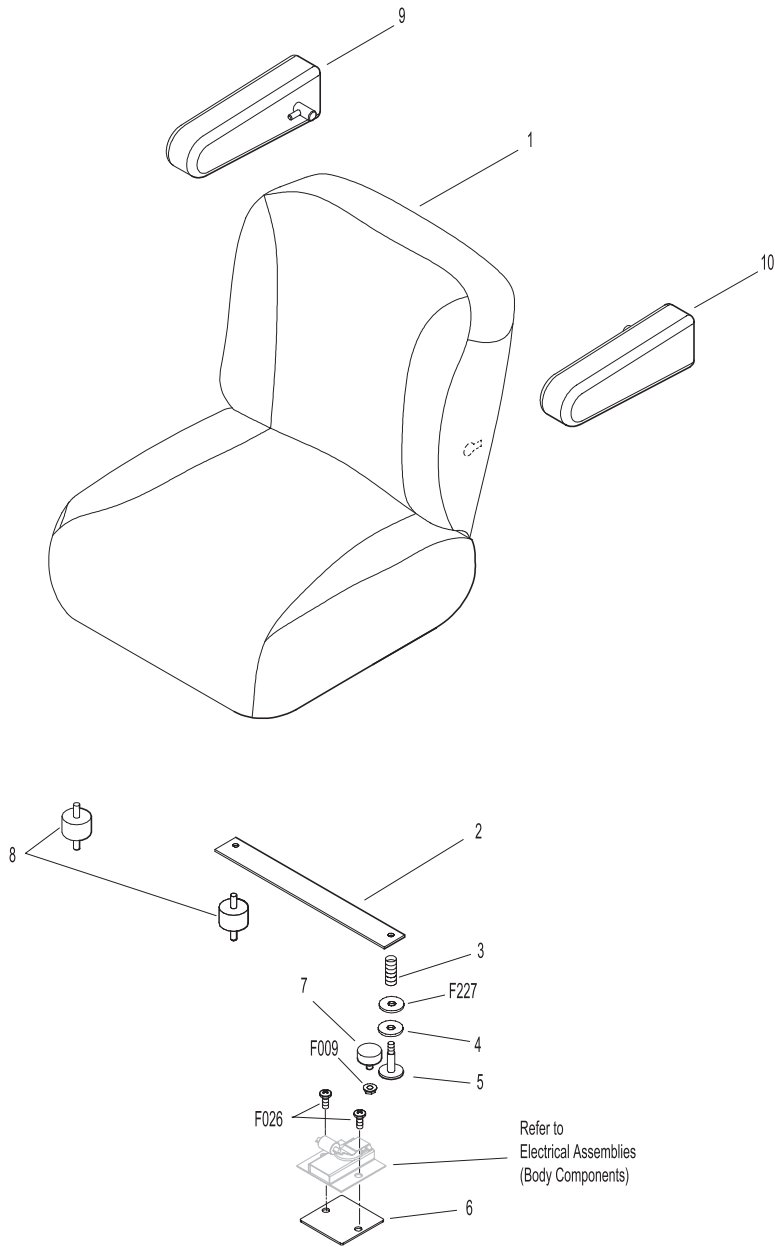

SUSPENSION SEAT KIT

ITEM NO.	PART NO.	DESCRIPTION	NO. REQ'D
----------	----------	-------------	-----------

Kit 6103-9 Armrest Kit

Includes Items # 1-6 and instructions. May be ordered as a factory-installed option or as a kit for dealer installation. Contact your Walker dealer.

1	6103-92	Armrest, RH	1
2	NS	5/8 Nut Cover	4
3	NS	7/16-20 x 13/4 HHCS	4
4	NS	3/8 SAE Washer	4
5	NS	Bushing, 3/4 x 3/4	4
6	6103-91	Armrest, LH	1

Kit 6103-25 Suspension Seat Option / Kit

Includes Items # 7-9, 11-13, 17, 20, fasteners listed (except as indicated; refer to **NOTE**) and instructions. May be ordered as a factory-installed option or as a kit for dealer installation. Contact your Walker dealer.

7	6103-11	Suspension Seat	1
8	5941-5	Safety Switch (Normal Open)	*
9	6103-33	Seat Mount Plate, LH	1
10	7223	Compression Spring (1/2 x 1)	2
11	5975-3	Cable Tie (50# x 7")	2
12	5975-1	Cable Tie (18# x 3-3/4")	1
13	6103-23	Wire Harness, C/D/T Suspension Seat	1
14	7846	Rubber Washer (3/8 x 1-1/4 x 1/8)	2
15	7204	Shoulder Bolt, Seat Mount	2
16	5453-20	Steering Lever Handle (+1"), Adj.	2
17	5977-5	Grommet (5/8)	2
18	5841	Retainer Washer	2
19	7845	Rubber Bumper (1.375 x 0.63)	2
20	7440-5	Shock Mount (1.25 x 0.75)	2
21	6103-34	Seat Mount Plate, RH	1

ITEM NO.	PART NO.	DESCRIPTION	NO. REQ'D
----------	----------	-------------	-----------

Fasteners

F002	10-24 Keps Nut	4
F009	5/16-18 Whiz Locknut	4
F026	10-24 x 1/2 PPHMS	4
F168	5/16 Split Lock Washer	4
F227	3/8 x 1-1/4 x 1/8 Washer (Plastic)	2
F357	M8 x 16 Hex Bolt	2
F358	M8 x 25 Hex Bolt	2

* Only one switch is included with kit. One is reused from Seat Assembly. Refer to **BODY / CHASSIS ASSEMBLY (GHS MODELS)**, Page 4.

NOTE: Reuse items # 8, 10, 14-16, 18, two (2) each of the F002, F009 and F026 fasteners, and item # F227 from Seat Assembly. Refer to **BODY / CHASSIS ASSEMBLY (GHS MODELS)**, Page 4.

SUSPENSION SEAT KIT

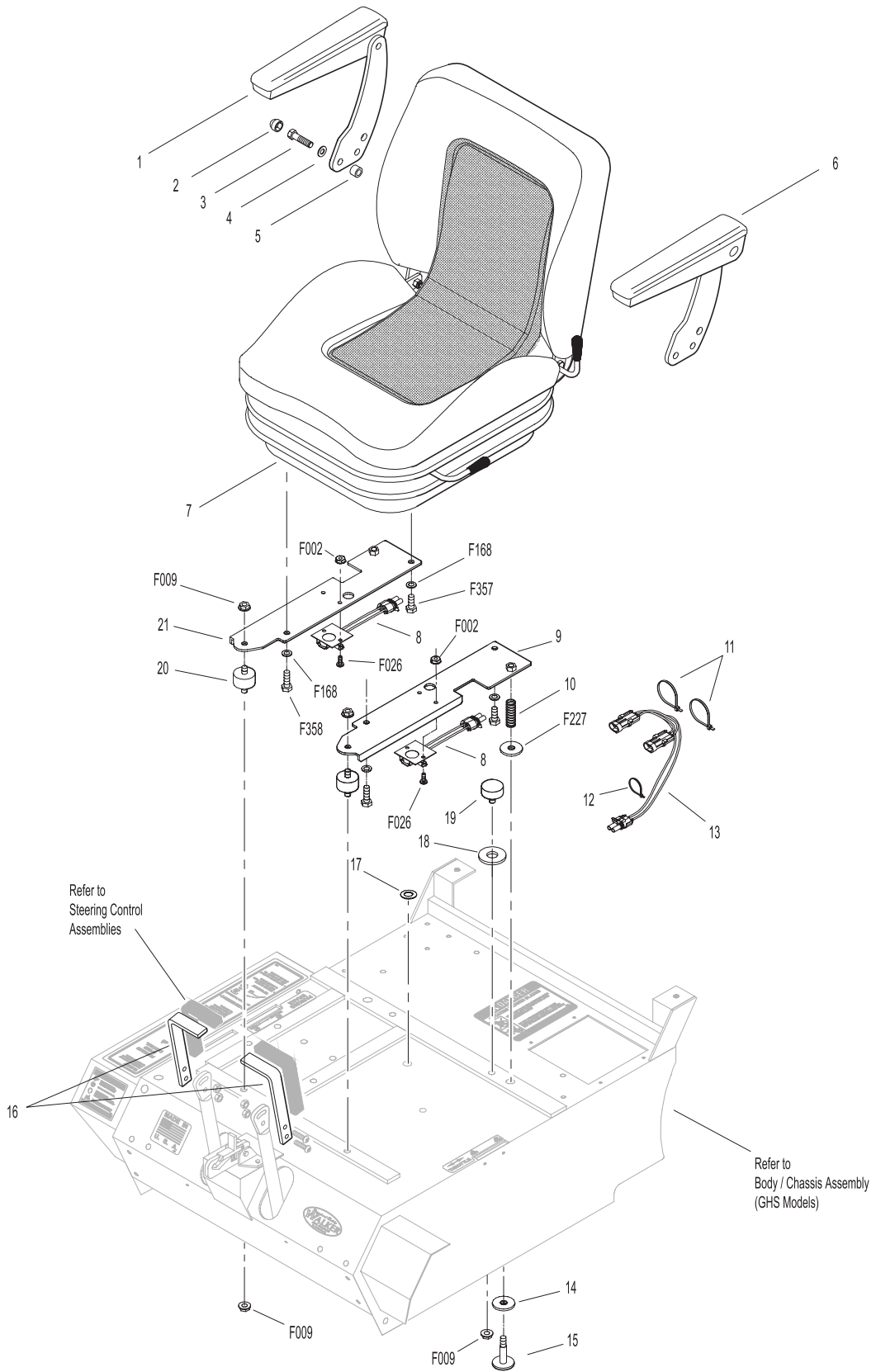

LIGHT KIT

ITEM NO.	PART NO.	DESCRIPTION	NO. REQ'D
----------	----------	-------------	-----------

Kit 7989-1 Light Option / Kit

Includes Items # 1-8, fasteners listed and instructions. May be ordered as a dealer-installed option. Contact your Walker dealer.

1	5989-2	Light Assembly (Includes Sealed Beam Lamp)	2
	5989-6	Sealed Beam Lamp (Fits P/N 5989-2)	*
2	5996-15	12-10 Gauge Ring Terminal (1/2)	2
3	7834-1	Half U-Wire Clip	4
4	7993	Mount Bracket, Lights	1
5	7995-3	Power Lead Wire Assembly (Lights)	1
6	5977-1	Grommet (1/8 x 3/8)	2
7	5975-5	Wire Clip, Self-Mount	3
8	5975-1	Cable Tie (18# x 3-3/4")	1

ITEM NO.	PART NO.	DESCRIPTION	NO. REQ'D
----------	----------	-------------	-----------

Fasteners

F009	5/16-18 Whiz Locknut	2
F091	5/16-18 x 5/8 Hex Bolt	2
F134	AN960816L Washer	2

* Service Part Only

NOTE: Upon installation of kit, Item # 6 replaces P/N 5989-4 (Dome Plug, 3/8) and Item # F091 replaces P/N 5989-3 (Dome Plug, 5/16). Dome Plugs are not shown here. Refer to **BODY / CHASSIS ASSEMBLY (GHS MODELS)**, Page 4.

NOTE: Refer to **ELECTRICAL CONNECTORS**, Page 42 for identification of all Electrical Wiring Service Parts.

LIGHT KIT

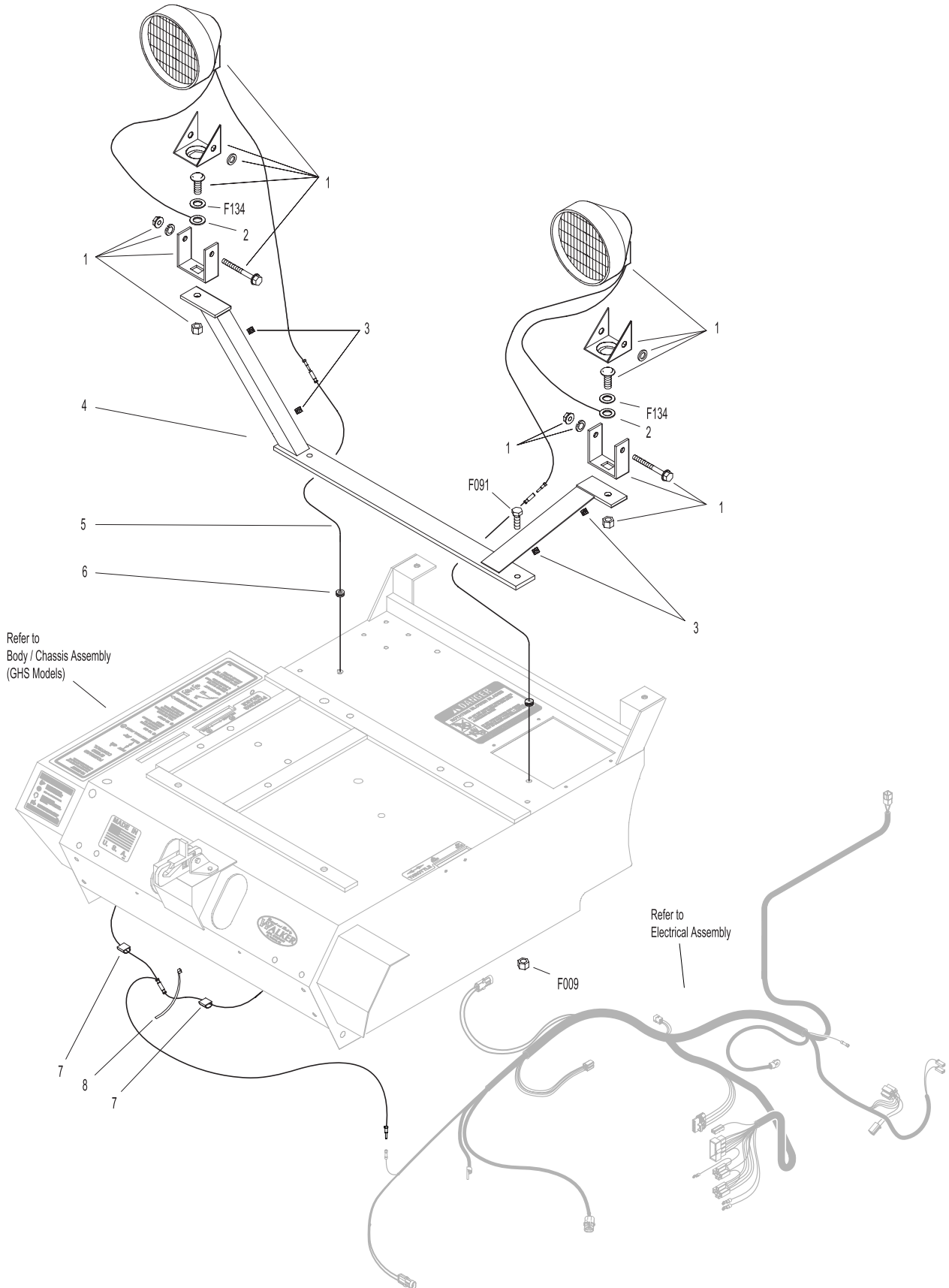

CASE-HARDENED BLOWER KIT

ITEM NO.	PART NO.	DESCRIPTION	NO. REQ'D	ITEM NO.	PART NO.	DESCRIPTION	NO. REQ'D
Kit 6542-15 Case Hardened Blower Option / Kit Includes Items # 1-5, fasteners listed and instructions. May be ordered as a factory-installed option or as a kit for dealer installation. Contact your Walker dealer.				Fasteners			
1	5268	Bearing (3/4" Includes Locking Collar	2	F004		1/4-20 Keps Nut	6
2	6543-15	Blower Housing (10") HT	1	F074		1/4-20 x 3/8 Set Screw	2
3	6545-15	Blower Wheel (10") HT	1				
4	6525-2	Faceplate (10" Blower)	1				
5	6526	Intake Tube (6-1/2 x 2-1/2)	1				
6	6542-50	Decal, "H" (5/8)	1				

CASE-HARDENED BLOWER KIT

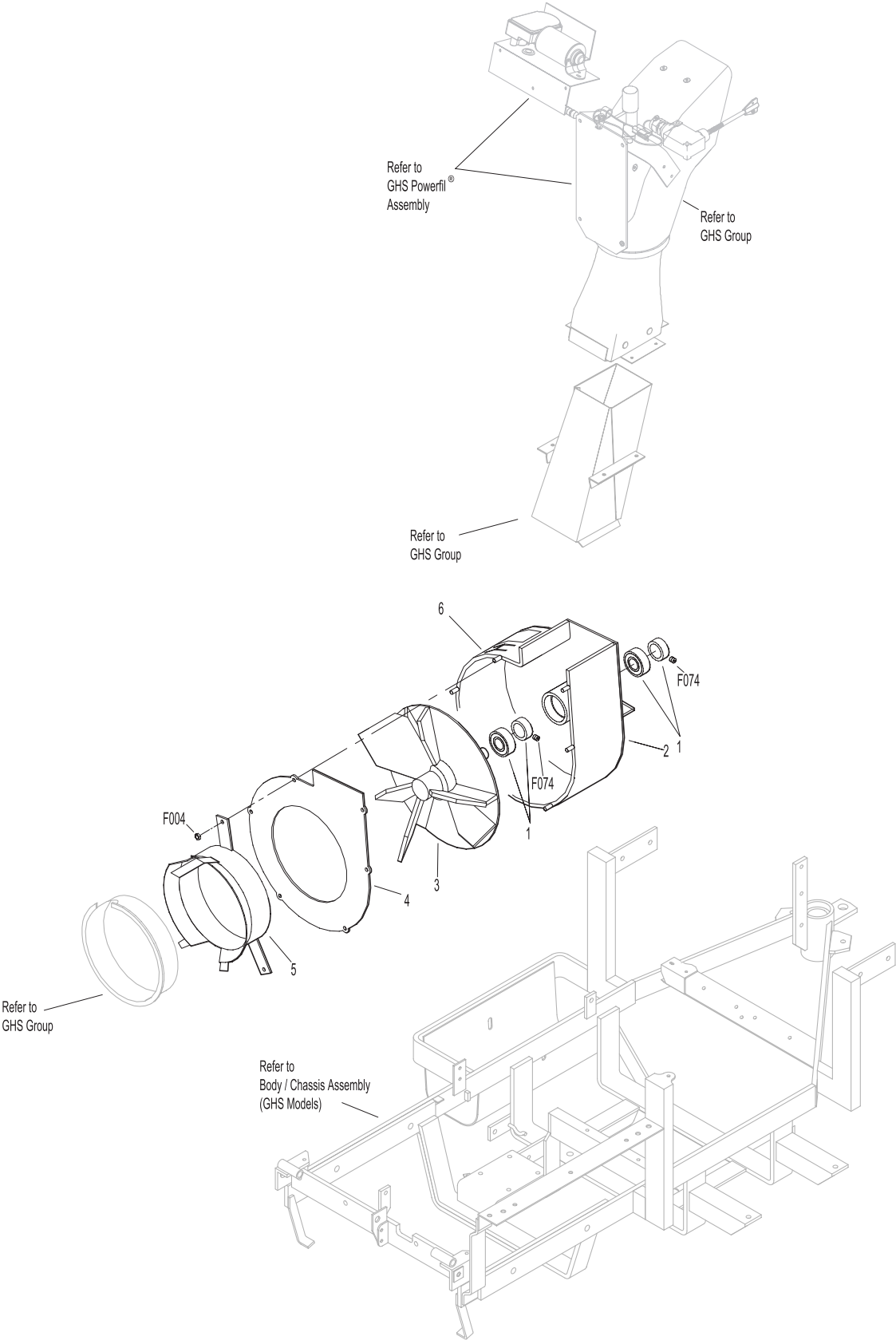

SPEED UP KIT

ITEM NO.	PART NO.	DESCRIPTION	NO. REQ'D
----------	----------	-------------	-----------

Kit 7247 Speed-Up Kit

Includes Items # 1-2 and instructions.

May be ordered as a factory-installed option or as a kit for dealer installation. Contact your Walker dealer.

1	7240-1	Jackshaft Drive Pulley (3-1/2/3/4/3V) (Includes Items # F067 & F171)	1
2	6238	Drive Belt (3VX345)	1

ITEM NO.	PART NO.	DESCRIPTION	NO. REQ'D
----------	----------	-------------	-----------

Fasteners

F067		3/16 x 3/16 x 1 Key	1
F171		5/16-18 x 3/8 Set Screw	*

* Service Part Only

NOTE: Used on Serial Number 02-60025 and after.

SPEED UP KIT

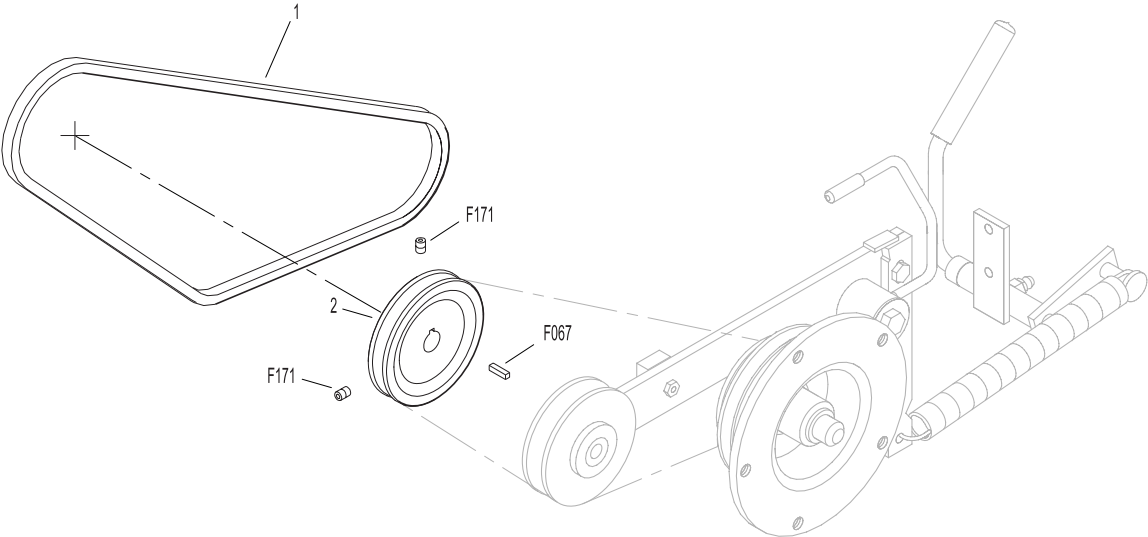

POWER DUMP KIT (7.0 BUSHEL GHS MODELS ONLY)

ITEM NO.	PART NO.	DESCRIPTION	NO. REQ'D	ITEM NO.	PART NO.	DESCRIPTION	NO. REQ'D
Kit 7620-13 Power Dump Option / Kit (7.0 Models Only) Includes Items # 1-31, fasteners listed and instructions. May be ordered as a factory-installed option or as a kit for dealer installation. Contact your Walker dealer. Not to be used with optional Dump Bag Kits.				Fasteners			
1	7620-3	Door Pivot Bushing	2	F002		10-24 Keps Nut	5
2	7612-2	Door Actuator Arm, RH	1	F003		1/4-28 Hex Nut	4
3	7612-1	Door Actuator Arm, LH	1	F004		1/4-20 Keps Nut	4
4	7610-5	Extension Spring, 1/4 x 2-7/8	1	F009		5/16-18 Whiz Locknut	4
5	7523-2	Clevis Pin (1/4 x 5/8)	2	F012		3/8-16 Keps Nut	2
6	7623	Power Dump Cable (7.0)	2	F028		10-24 x 3/4 PPHMS	4
7	5975-7	Cable Tie (50# x 11")	1	F029		1/4-20 x 1/2 Hex Bolt	4
8	7621	Linear Actuator 7.0	1	F032		1/4-20 x 3/4 Hex Bolt	1
9	5552	Ball Joint (1/4-28)	2	F039		3/8-16 x 1-1/4 Hex Bolt	2
10	7628-1	Channel Angle, RH	1	F049		5/16 SAE Washer	2
11	7620-9	Roller Wheel	2	F050		1/4 SAE Washer	2
12	7629	Channel Angle, LH	1	F068		1/8 x 1 Cotter Pin	2
13	5830	Grease Fitting	3	F069		3/32 x 1/2 Cotter Pin	4
14	7626-0	Actuator Mount	1	F079		A/A66D Aluminum Pop Rivet	1
15	7624-1	Roller Bearing Bolt	1	F085		3/16 Rivet Backup Washer	4
16	5832	Cable Clamp (1/2)	1	F093		5/16-18 x 1 Hex Bolt	1
17	7627	Front Actuator Mount	1	F111		1/8 x 3/4 Cotter Pin	1
18	7624	Sealed Needle Bearing	1	F128		10-24 x 3/8 PTHMS	2
19	7630-3	Ram Pivot and Spacer	1	F134		AN960816L Washer	4
20	7625	Fork	1	F249		M10 Split Lock Washer	2
21	5975-1	Cable Tie (18# x 3-3/4")	1	F266		1/2 x 2-3/4 Shoulder Bolt	1
22	5975-3	Cable Tie (50# x 7")	5	F267		1/2 x 1 x 1/16 Washer	4
23	7622	Wire Harness	1	F269		10-32 x 5/8 PTHMS	4
24	6623	Toggle Switch	1	F270		10-32 Cap Nut	4
25	6623-1	Switch Boot	1				
26	7633	Decal, Power Dump	1				
27	7104-5	Rear Body Panel, LH	1				
28	8105-4	Rear Body Panel, RH	1				
29	7620-12	Cable Rod Guide (7.0)	2				
30	7620-6	Cable Guide	2				
31	7613	Door Actuator	2				

NOTE: Two F009 Fasteners are reused from the Rear Gas Spring Assembly. Refer to **REAR BODY ASSEMBLY (GHS MODELS)**, Page 6.

NOTE: Refer to **ELECTRICAL CONNECTORS**, Page 42 for identification of all Electrical Wiring Service Parts.

POWER DUMP KIT (7.0 BUSHEL GHS MODELS ONLY)

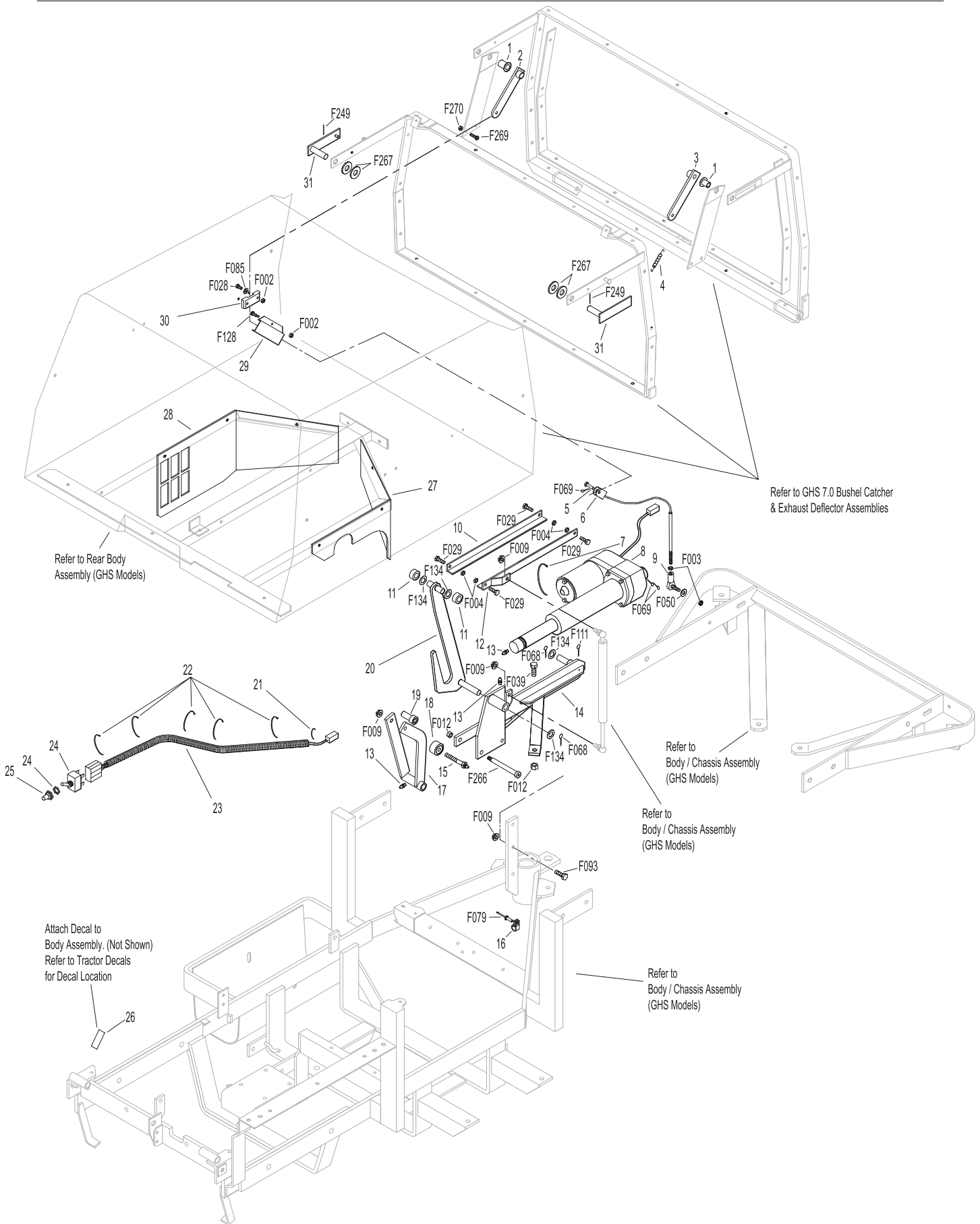

Effective Date 03-01-03

Use only genuine Walker® replacement parts.

POWER DUMP KIT (9.5 BUSHEL GHS MODELS ONLY)

ITEM NO.	PART NO.	DESCRIPTION	NO. REQ'D	ITEM NO.	PART NO.	DESCRIPTION	NO. REQ'D
Kit 8620-1 Power Dump Option / Kit (9.5 Models Only) Includes Items # 1-31, fasteners listed and instructions. May be ordered as a factory-installed option or as a kit for dealer installation. Contact your Walker dealer.				Fasteners			
1	7620-3	Door Pivot Bushing	2	F002		10-24 Keps Nut	6
2	7612-2	Door Actuator Arm, RH	1	F003		1/4-28 Hex Nut	4
3	7612-1	Door Actuator Arm, LH	1	F004		1/4-20 Keps Nut	4
4	7610-5	1/4 x 2-7/8 Extension Spring	1	F009		5/16-18 Whiz Locknut	3
5	7523-2	Clevis Pin (1/4 x 5/8)	2	F012		3/8-16 Keps Nut	2
6	7623-2	Power Dump Cable (9.5)	2	F028		10-24 x 3/4 PPHMS	2
7	5975-7	Cable Tie (50# x 11")	1	F029		1/4-20 x 1/2 Hex Bolt	4
8	7721	Linear Actuator 9.5	1	F039		3/8-16 x 1-1/4 Hex Bolt	2
9	5552	Ball Joint (1/4-28)	2	F050		1/4 SAE Washer	1
10	8620-5	Guard, 9.5 P.D. Motor	1	F068		1/8 x 1 Cotter Pin	2
11	7628-1	Channel Angle, RH	1	F069		3/32 x 1/2 Cotter Pin	4
12	7620-9	Roller Wheel	2	F079		A/A66D Aluminum Pop Rivet	1
13	7629	Channel Angle, LH	1	F085		3/16 Rivet Backup Washer	4
14	5830	Grease Fitting	3	F093		5/16-18 x 1 Hex Bolt	2
15	7636-1	Actuator Mount, 9.5	1	F111		1/8 x 3/4 Cotter Pin	1
16	7624-1	Roller Bearing Bolt	1	F134		AN960816L Washer	4
17	5832	Cable Clamp (1/2)	1	F249		M10 Split Lock Washer	2
18	7627	Front Actuator Mount	1	F266		1/2 x 2-3/4 Shoulder Bolt	1
19	7624	Sealed Needle Bearing	1	F267		1/2 x 1 x 1/16 Washer	4
20	7630-3	Ram Pivot and Spacer	1	F269		10-32 x 5/8 PTHMS	4
21	7625	Fork	1	F270		10-32 Cap Nut	4
22	5975-1	Cable Tie (18# x 3-3/4")	1	F337		1/4 - 20 x 5/8 Self Tap Bolt	2
23	5975-3	Cable Tie (50# x 7")	5				
24	7622	Wire Harness	1				
25	6623	Toggle Switch	1				
26	6623-1	Switch Boot	1				
27	7633	Decal, Power Dump Switch	1				
28	7104-5	Rear Body Panel, LH	1				
29	8105-4	Rear Body Panel, RH	1				
30	7620-6	Cable Rod Guide	2				
31	7613	Door Actuator	2				

NOTE: Two F009 Fasteners are reused from the Rear Gas Spring Assembly. Refer to **REAR BODY ASSEMBLY (GHS MODELS)**, Page 6.

NOTE: Refer to **ELECTRICAL CONNECTORS**, Page 42 for identification of all Electrical Wiring Service Parts.

POWER DUMP KIT (9.5 BUSHEL GHS MODELS ONLY)

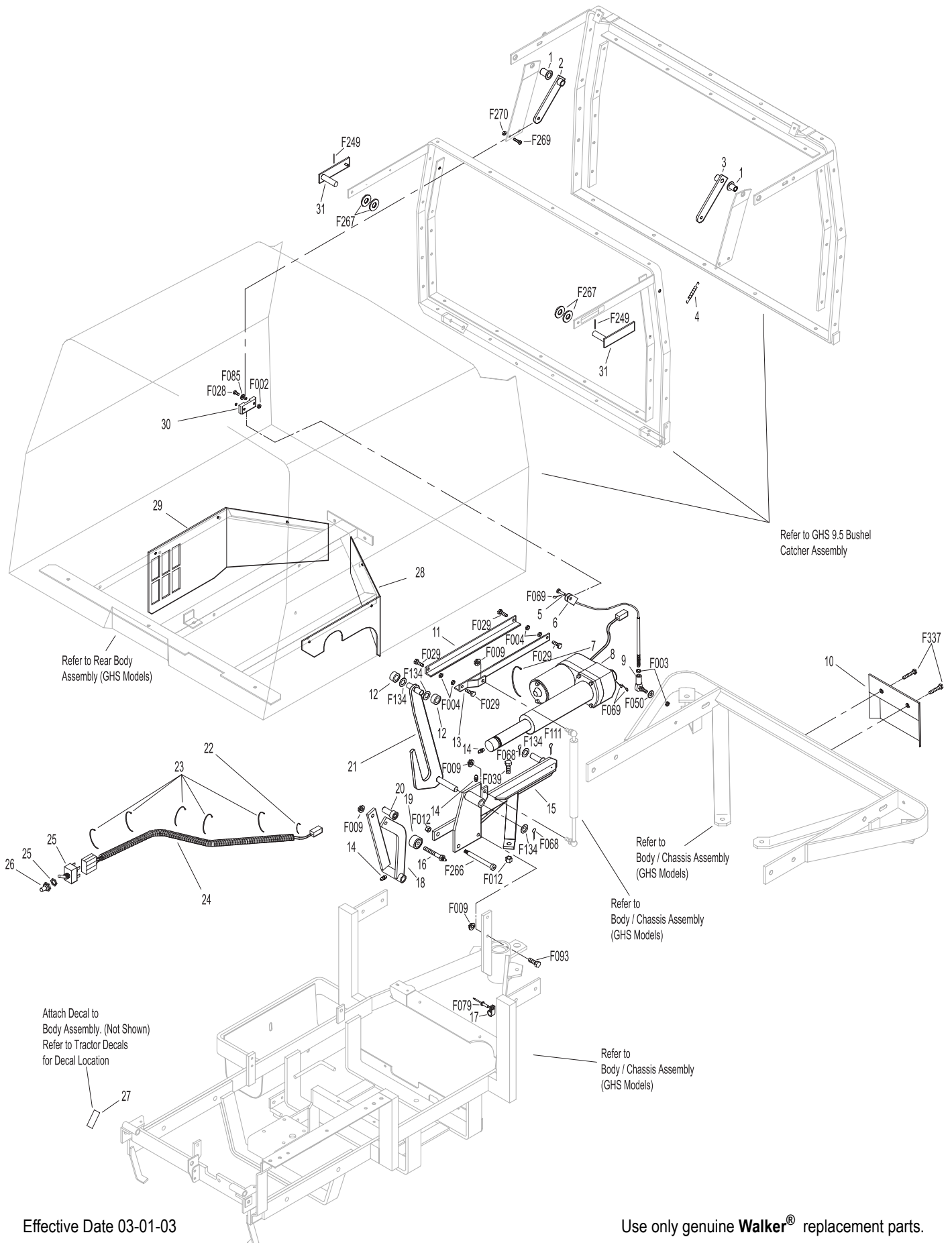

Effective Date 03-01-03

Use only genuine Walker® replacement parts.

NO CATCH DEFLECTOR KIT (7.0 BUSHEL & 9.5 BUSHEL)

ITEM NO.	PART NO.	DESCRIPTION	NO. REQ'D
----------	----------	-------------	-----------

Kit 7500 (7.0 Bushel) No Catch Deflector Option / Kit
Includes item numbers 1 (7500-1) thru 5, fasteners listed and instructions.

Kit 8500 (9.5 Bushel) No Catch Deflector Option / Kit
Includes item numbers 1 (8500-1) thru 5, fasteners listed and instructions.

Both kits may be ordered as a factory-installed option or as a kit for dealer installation. Contact your Walker dealer.

1	7500	Deflector Assembly, (7.0)	1
	8500	Deflector Assembly (9.5)	1
2	8500-5	Side Bracket	2
3	8787-2	Deflector Knob	1
4	8500-6	Spacer Lug	1
5	8500-8	Decal, No Catch Deflector	1

ITEM NO.	PART NO.	DESCRIPTION	NO. REQ'D
----------	----------	-------------	-----------

Fasteners

F002		10-24 Keps Nut	4
F030		1/4-20 x 1/2 PPH Bolt	1
F128		10-24 x 3/8 PTHMS	4
F333		1/4-20 x 3/4 PTHMS	1

NO CATCH DEFLECTOR KIT (7.0 BUSHEL & 9.5 BUSHEL)

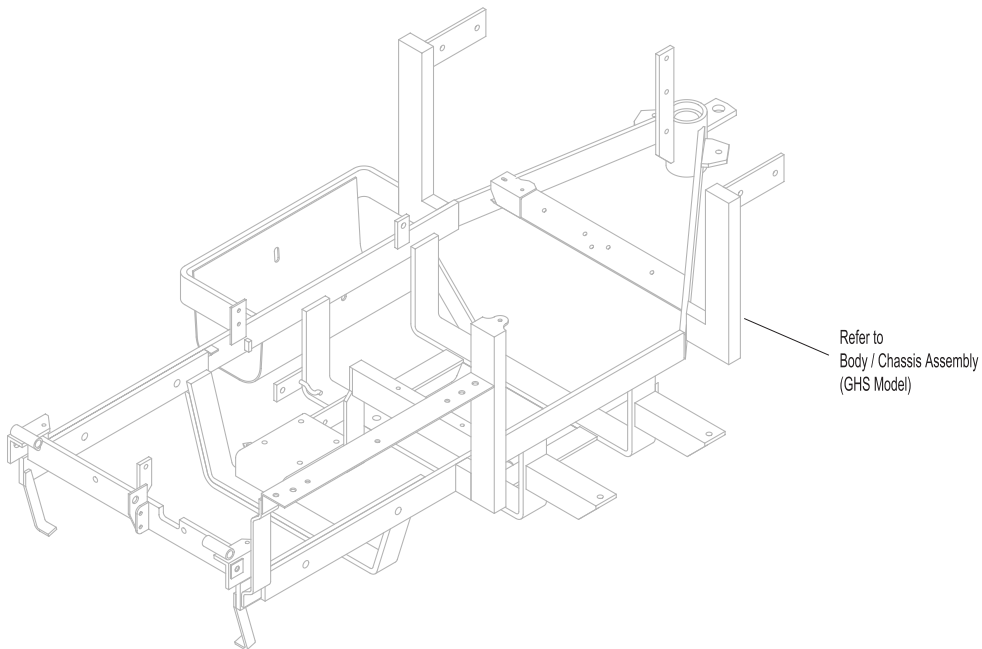
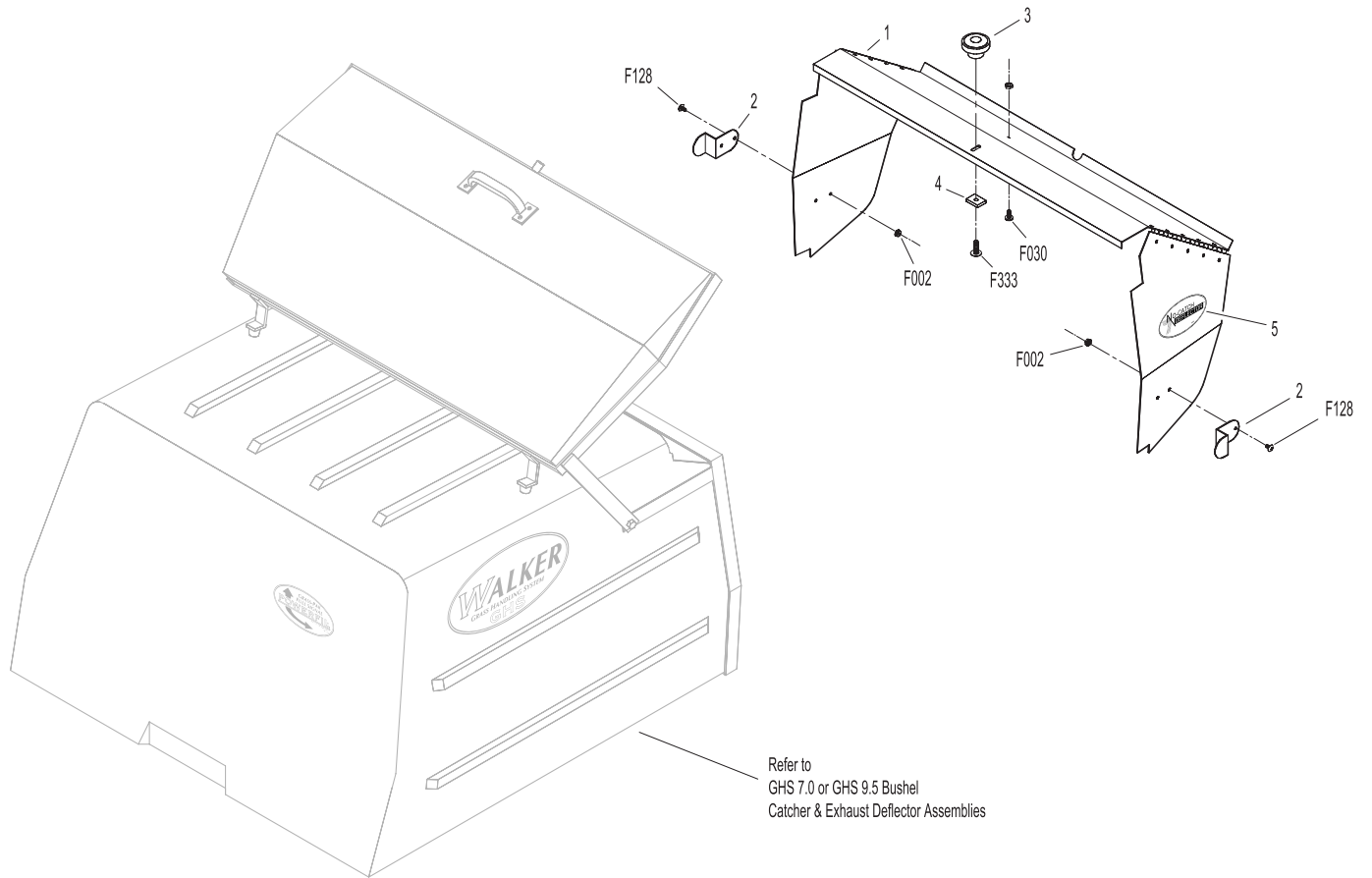

TAIL WEIGHT KIT

ITEM NO.	PART NO.	DESCRIPTION	NO. REQ'D	ITEM NO.	PART NO.	DESCRIPTION	NO. REQ'D
Kit 7647 Tail Weight Option / Kit Includes Items # 2, 3, F012, F039, and instructions. May be ordered as a factory-installed option or as a kit for dealer installation. Contact your Walker dealer.				Fasteners			
1	7647-9	Tail Weight Strap	2		F012	3/8-16 Keps Nut	4
2	7647-5	Tail Weight Plate, 10-lb	*		F039	3/8-16 x 1-1/4 Hex Bolt	4
3	NS	Tractor Tail Weight	1		F175	1/2 Split Lock Washer	2**
					F285	1/2-13 x 1-1/2 Hex Bolt	2**
				*	Optional		
				**	Use with optional 10-lb plate.		

TAIL WEIGHT KIT

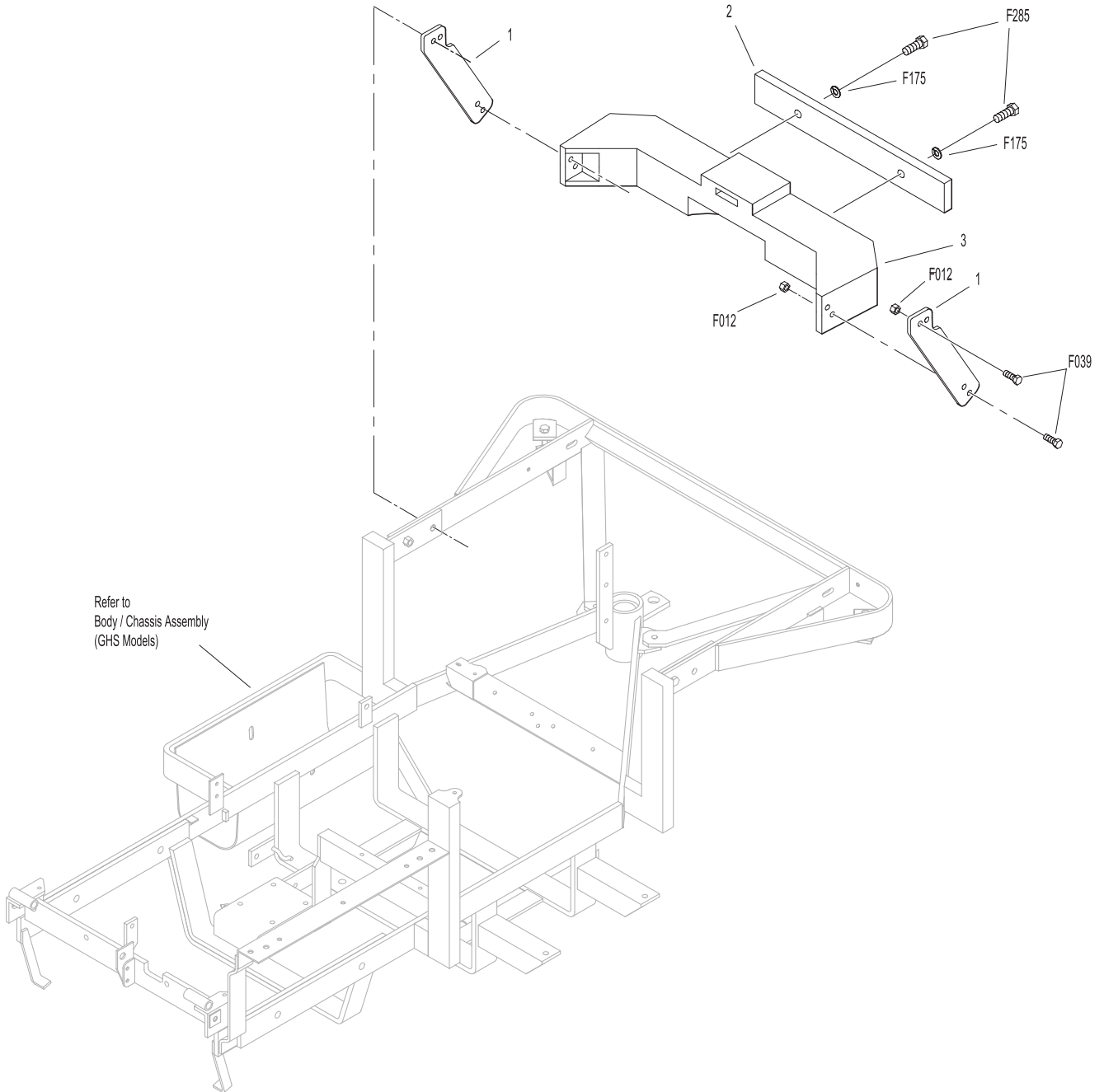

TAIL WHEEL LOCK KIT

ITEM NO.	PART NO.	DESCRIPTION	NO. REQ'D	ITEM NO.	PART NO.	DESCRIPTION	NO. REQ'D
Kit 8540 Tail Wheel Lock Option / Kit Includes Items # 1-29, fasteners listed & instructions. May be ordered as a dealer-installed option. Contact your Walker dealer.				Fasteners			
1	5995-2	Switch Boot	1	F002		10-24 Keps Nut	4
2	8547	Switch Mount	1	F003		1/4-28 Hex Nut	1
3	8555	Decal, Tail Lock Switch	1	F004		1/4-20 Keps Nut	3
4	5995	Toggle Switch (Off-On)	1	F012		3/8-16 Keps Nut	2
5	7942-4	Single Connector, Male	2*	F026		10-24 x 1/2 PPHMS	2
6	5940-4	16-14 GA Spg. Loaded Term., Female	5*	F029		1/4-20 x 1/2 Hex Bolt	2
7	5977-1	Grommet, Cut (1/8 x 3/8)	1	F038		3/8-16 x 1 Hex Bolt	2
8	5975-3	Cable Tie (50# x 7")	4	F050		1/4 SAE Washer	2
9	8550	Wire Harness	1	F134		AN960816L Washer	1
10	5975-1	Cable Tie (18# x 3-3/4")	3	F179		1/4-20 x 1 Hex Bolt	2
11	8553	Splice Tap (18-14 GA)	1	F190		#10 Internal Star Lock Washer	1
12	8543	Solenoid Mount	1	F198		.250 x .625 x .040 Washer, SS	1
13	5830-3	Grease Fitting (45 Degree)	1	F298		3/8-24 Jam Nut	1
14	8551	Ground Wire	1	F299		10-24 x 1 PPHMS	2
15	8546	Solenoid, Control Module	1	F300		1.015 x 1.500 x .031 Washer	1
16	5996	1/4 16-14 GA QKS Term., Female	5*	* Service Part Only			
17	8552	Connector Plug & Wire Assy	1	** Replaces P/N 7941-2 (Circuit Breaker, 10 Amp). Refer to INSTRUMENT PANEL ASSEMBLY, Page 36.			
18	8544	Clevis, Wheel Lockout	1	NOTE: Refer to ELECTRICAL CONNECTORS , Page 42 for identification of all Electrical Wiring Service Parts.			
19	5555-1	Pivot Bearing	2*	NOTE: Upon installation of kit, Item # 4 replaces P/N 5989-4 (Dome Plug, 3/8). Dome Plugs are not shown here. Refer to BODY / CHASSIS ASSEMBLY (GHS MODELS) , Page 4.			
	8545-1	Pivot Bearing Assembly (Includes Items # 15, 16, F179, F350)	*				
20	8544-1	Bearing Spacer, Lockout	1*				
21	8542	Tail Wheel Fork, Locking	1				
22	8944	3 Way Locking Connector, Male	1*				
23	8944-1	3 Way Locking Connector, Female	1*				
24	5940-5	16-14 GA Spg. Loaded Term., Male	1*				
25	5996-13	16-14 GA Ring Term., #10	1*				
26	7929	Actuating Solenoid	1				
27	8549	Sleeve, Delrin	1				
28	8541	Plunger Rod	1				
	8554	Solenoid & Mount Assembly (Includes Items # 7, 8, 11-20, 22-27, F002, F003, F004, F029, F050, F179, F190, F198, F298 & F299)	*				
29	7941-4	Circuit Breaker	**				

TAIL WHEEL LOCK KIT

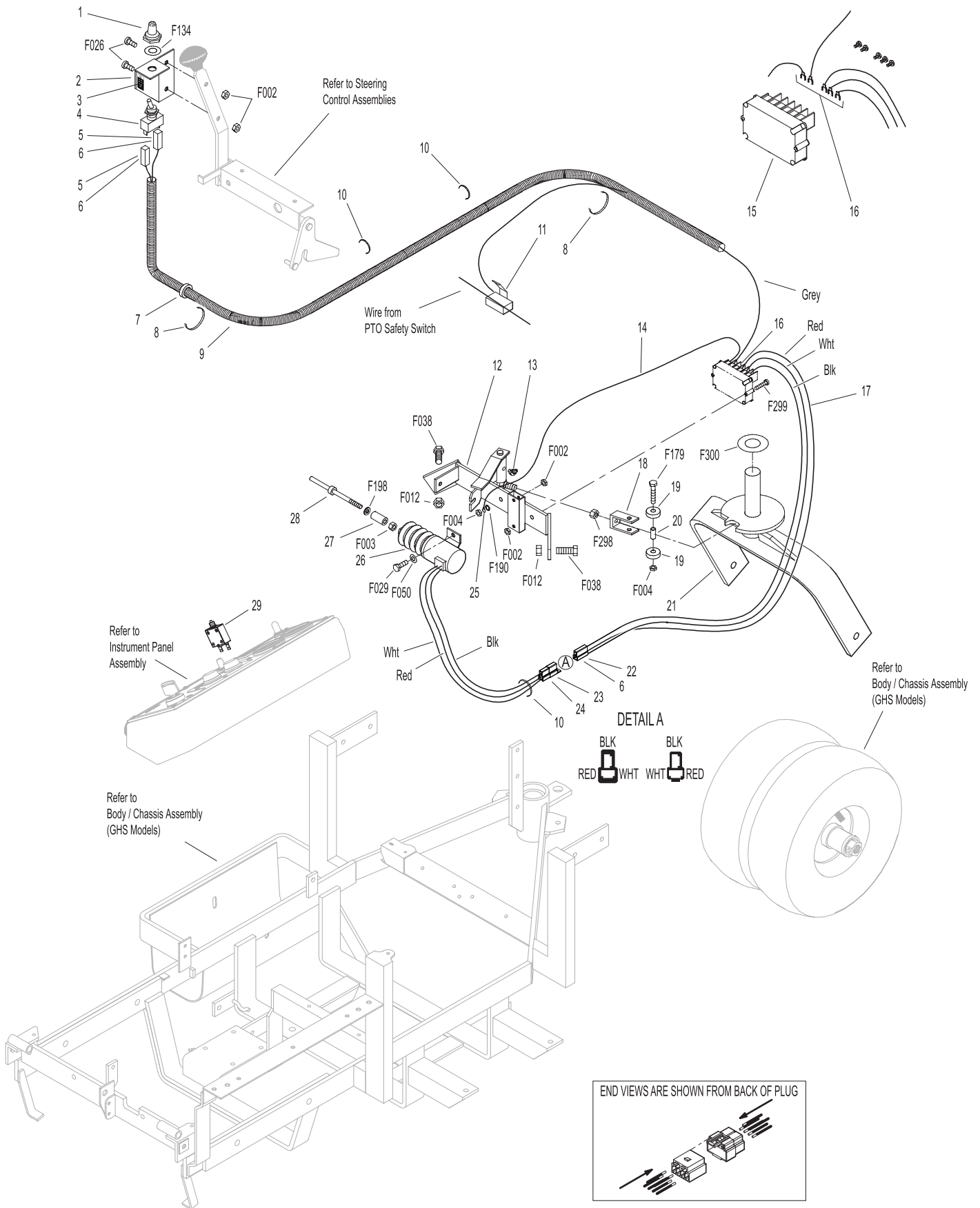

Effective Date 03-01-03

Use only genuine Walker® replacement parts.

WIDE TAIL WHEEL / ALL-TERRAIN TIRE KIT & TIRE CHAIN SET

ITEM NO.	PART NO.	DESCRIPTION	NO. REQ'D
----------	----------	-------------	-----------

Kit 8049 Wide Tail Wheel Option / Kit
Includes Items # 1, 2, and instructions. May be ordered as a dealer-installed option. Contact your Walker dealer.

1	8037-1	Seal, Tail Wheel	2
2	8045	Wide Tail Wheel & Tire (13 x 8.00-6)	1
	8045-1	Wide Tire (13 x 8.00-6)	*
	8047	Wheel & Hub Only (6 x 7)	*

Kit 8072 All-Terrain Tire Option / Kit
Includes Items # 3-5, and instructions. May be ordered as a dealer-installed option. Contact your Walker dealer.

3	8071	All-Terrain Wheel & Tire, LH (18 x 11.00-10)	1
4	8070-31	Wheel Spacer Plate (1/2)	2♦
5	8070	All-Terrain Wheel & Tire, RH (18 x 11.00-10)	1
	8070-1	AT Tire (18 x 11.00-10)	*
	8070-2	AT Wheel (10 x 8.5)	*
	8075-2	AT/LP Tire Tube (18 x 11-10)	*

ITEM NO.	PART NO.	DESCRIPTION	NO. REQ'D
----------	----------	-------------	-----------

Kit 8075 Low Profile Tire Option / Kit
Includes Item # 6, and instructions. May be ordered as a factory-installed option, or as a kit for dealer installation. Contact your Walker dealer.

6	8075	Low Profile Wheel & Tire (18 x 10.5-10) (Includes Item # 4)	2
	8075-1	LP Tire Only (18 x 10.5-10)	*
	8070-2	AT/LP Wheel Only (10 x 8.5)	*
	8075-2	AT/LP Tire Tube (18 x 11-10)	*

Optional Tire Chain Set

Includes Items # 4 and 6. Tire Chain Sets are not for use on All-Terrain or Low Profile Tires. Use only with tires listed at Item # 6. Refer also to **BODY / CHASSIS ASSEMBLY (GHS MODELS)**, Page 4.

7	5675-3	Tire Chain Set (18 x 9.50-8) (For use with Wide Wheel and Tire Assy)	1
---	--------	--	---

* Service Part Only

♦ Wheel Spacer Plates (Item 4) are included with Tire Chain Sets as well as with 8072 All-Terrain Tire Kit.

WIDE TAIL WHEEL / ALL-TERRAIN TIRE KIT & TIRE CHAIN SET

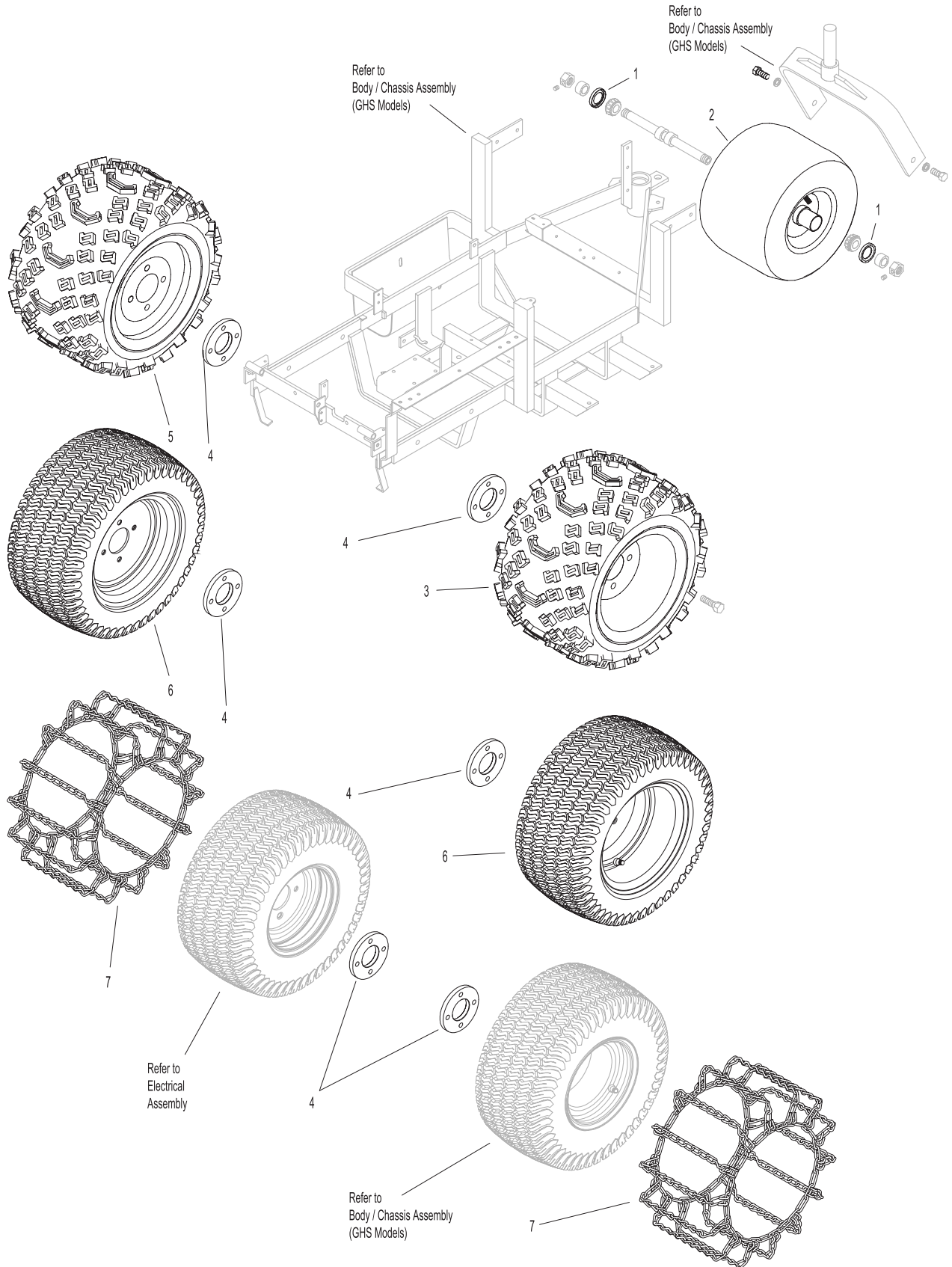

LUBRICATION POINTS

ITEM NO.	PART NO.	DESCRIPTION	NO. REQ'D	ITEM NO.	PART NO.	DESCRIPTION	NO. REQ'D
Lubrication Points				27	Engine Belt Idler Pulley	Oil	1
1	Deck Caster Wheel Fork Pivot	Grease	2	28	Throttle Control Cable Ends	Oil	2
2	Blade Drive Gearbox	Oil*	2	29	Cold Start Lever	Grease	1
3	Tee Gearbox, Deck	Oil*	1	30	Rear Bumper Roller Wheel	Oil	2
4	Deck Caster Wheel Bearing	Grease	2	31	Catcher Hinge Point	Oil	2
5	PTO Shaft Guard Hinge	Oil	1	32	Rear Wheel Axle	Grease	2
6	Universal Joint Shaft Assembly	Grease**	1	33	Engine Dipstick / Oil Filler	Oil***	1
7	Pivot Assembly, Tilt-Up Deck	Grease	4	34	Blower Belt Idler Pulley	Grease	1
8	Deck Support Arm Socket	Grease	2	35	PTO Gearbox Dipstick	Oil	1
9	Body Hinge Point	Oil	2	36	Ground Drive Idler Pulley	Oil	2
10	FSC Actuator Rod Pivot Pins	Oil	2	37	Hydrostatic Drive	Oil***	2
11	FSC Lever Pivot	Grease	1	38	Throttle Control Assembly	Oil	1
12	FSC Lever Fork	Grease	1	39	Discharge Chute Hinge	Oil	1
	(Grease Slide Area)			40	Steering Lever Support	Oil	1
13	(FSC) Friction Body Pivot	Grease	1	* Gearboxes are permanently lubricated and sealed requiring no scheduled lubrication. Oil level should be checked only when an oil leak is noted.			
14	Steering Lever Pivot	Grease	4	** Grease every eight (8) hours.			
15	Deck Roller Wheel	Oil	2	*** See Owner's Manual for procedure for checking and changing oil in Engine Crankcase, Hydrostatic Transmissions and Gear Axles.			
16	Deck Support Arm Pivot	Grease	2	NOTE: See Model MDD Owner's Manual (P/N 7000-1) for proper lubrication intervals.			
17	Deck-to-PTO Coupling	Grease	1	NOTE: DGHS42 Tilt-Up Mower Deck is shown for reference. For other Mower Deck Lubrication Points, Refer to Carrier Frames and Mower Decks Illustrated Parts Manual.			
18	Universal Joint Tube Assembly	Grease**	1				
19	Universal Joint Quick Connect Spline (Grease Slide Area)	Grease	1				
20	Parking Brake Lever	Grease	1				
21	Gear Axle	Oil***	2				
22	Belt Tightener Pivot, Ground Drive	Grease	1				
23	PTO Clutch Lever Pivot	Grease	1				
24	Clutch Actuator Push Rod	Grease	2				
25	Brake Actuator Rod and Brake Band Pivot Pins (Clevis)	Oil	3				
26	Idler Arm	Oil	1				

LUBRICATION POINTS

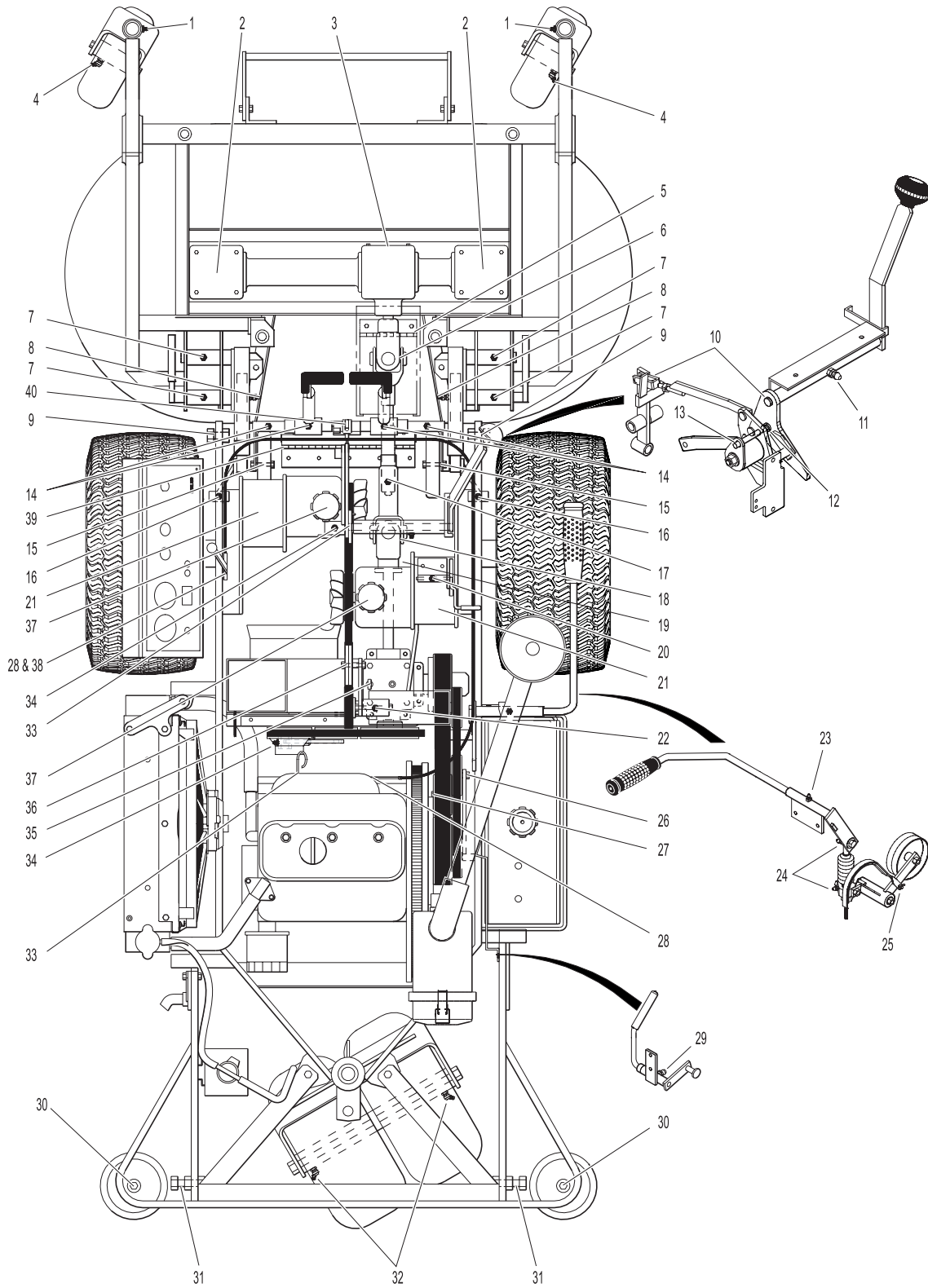

WIRING SCHEMATIC

WALKER MODEL MDD Beginning S/N 2001-49370

IGNITION SWITCH CIRCUITS	
OFF	ALL OPEN
GLOW PLUG	30 + 19 + AC
START	30 + 17 + 50 + AC
RUN	30 + AC

30 = BATTERY
17 = START / REVERSING MODULE
19 = GLOW PLUGS
50 = START
AC = FUEL PUMP, FUEL SOLENOID
GAUGES, AND FAN

RELAY - A FUEL SOLENOID START RELAY (PULL)	
OFF	30 + 87A
GLOW PLUG	30 + 87
START	30 + 87
RUN	30 + 87

RELAY - B WARNING RELAY	
OFF	30 + 87A
GLOW PLUG	OPEN
START	30 + 87A
RUN	30 + 87A

RELAY - C FUEL SOLENOID RUN RELAY (HOLD)	
OFF	OPEN
GLOW PLUG	30 + 87
START	30 + 87A
RUN	30 + 87A

RELAY - D FAN SPEED CONTROL	
OFF	30 + 87A
RUN (LOW)	30 + 87A
RUN (HIGH)	30 + 87

RELAY - E START/TIME DELAY RELAY	
OFF	30 + 87A
START	30 + 87A
PTO ON	OPEN

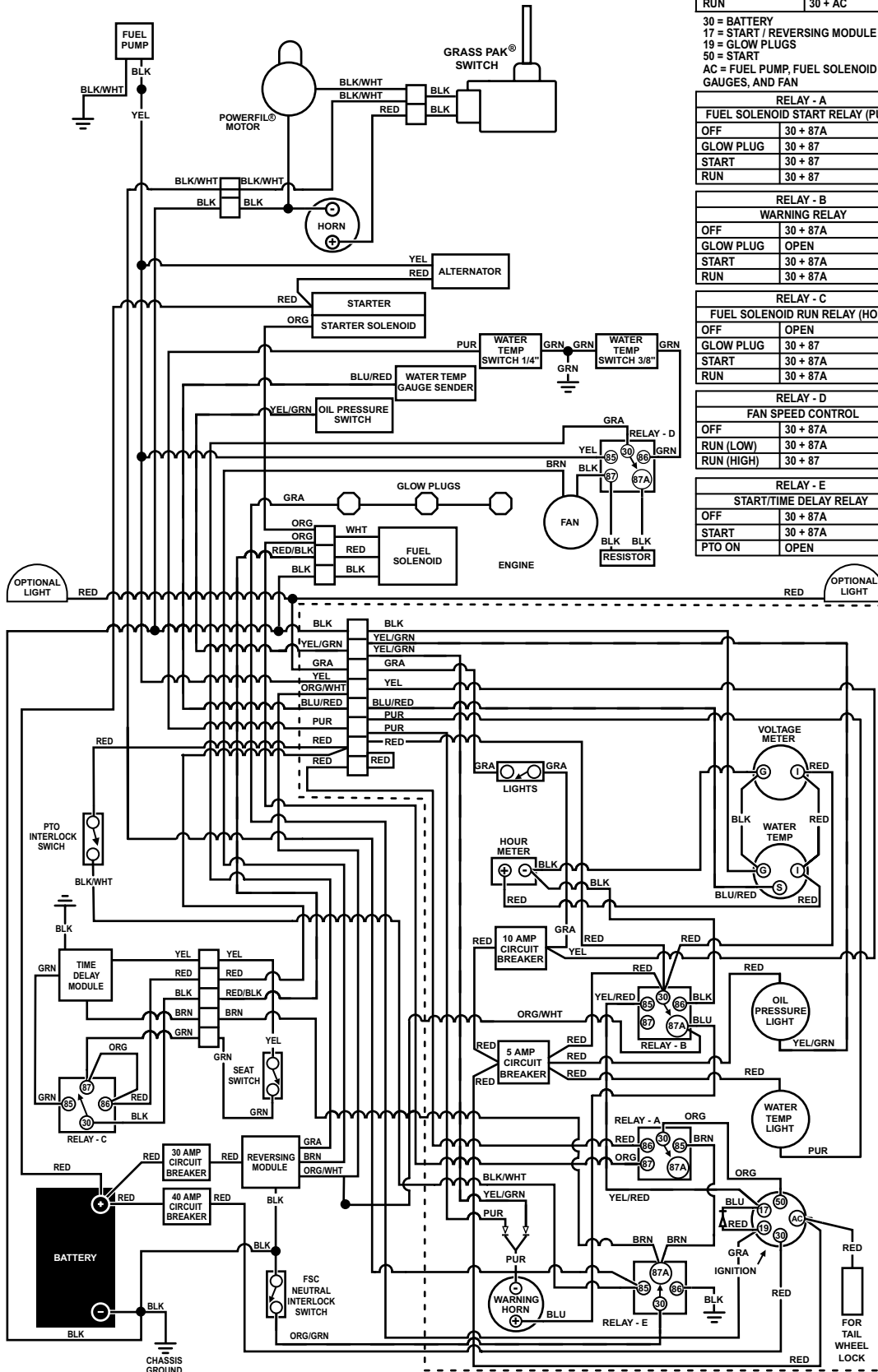

Use only genuine Walker® replacement parts.

Effective Date 03-01-03

LIMITED WARRANTY FOR WALKER COMMERCIAL RIDER MOWER

1. WHAT THIS WARRANTY COVERS, AND FOR HOW LONG:

Walker Manufacturing company will, at its option, repair or replace, without charge, any part covered by this warranty which is found to be defective in material and/or workmanship within one (1) year* after date of sale to the original retail purchaser unless the product is used for rental purposes, in which case this warranty is limited to ninety (90) days. At Walker's request, customer will make the defective part available for inspection by Walker and/or return the defective part to Walker, transportation charges prepaid. All parts and components of the Walker Mower are covered by this warranty **except** the following components which are warranted separately by their respective manufacturers:

Kohler Engine
Kubota Engine
Kawasaki Engine
Eaton Hydraulic Transmission
Peerless Gearboxes
Battery
Tires

The available warranties covering these items are furnished with each mower. Walker does not assume any warranty obligation, liability or modification for these items, which are covered exclusively by the stated warranty of the respective manufacturers noted above.

* An extended three (3) year warranty is offered on the Walker P/N 6200-8 Gear Axle Assembly.

2. WHAT THIS WARRANTY DOES NOT COVER:

- A. This warranty does not cover defects caused by depreciation or damage caused by normal wear, accidents, improper maintenance, improper use or abuse of the product, alterations, or failure to follow the instructions contained in the Owner's Manual for operation and maintenance.
- B. The customer shall pay any charges for making service calls and/or for transporting the mower to and from the place where the inspection and/or warranty work is performed.

3. HOW TO OBTAIN SERVICE UNDER THIS WARRANTY:

Warranty service can be arranged by contacting the dealer where you purchased the mower or by contacting Walker Manufacturing Company, 5925 East Harmony Road, Ft. Collins, CO 80528. Proof of the date of purchase may be required to verify warranty coverage.

4. WARRANTY LIMITATION:

- A. **THERE IS NO OTHER EXPRESS WARRANTY. ANY WARRANTY THAT MAY BE IMPLIED FROM THIS PURCHASE INCLUDING MERCHANTABILITY AND FITNESS FOR A PARTICULAR PURPOSE IS HEREBY LIMITED TO THE DURATION OF THIS WARRANTY AND TO THE EXTENT PERMITTED BY LAW ANY AND ALL IMPLIED WARRANTIES ARE EXCLUDED.** Some states do not allow limitations on how long an implied warranty lasts, so the above limitations may not apply to you.
- B. **WALKER WILL NOT BE LIABLE FOR ANY INCIDENTAL, CONSEQUENTIAL, OR SPECIAL DAMAGES AND/OR EXPENSES IN CONNECTION WITH THE PURCHASE OR USE OF THE MOWER.** Some states do not allow the exclusion or limitation of incidental or consequential damages, so the above limitation(s) or exclusion(s) may not apply to you.
- C. Only the warranty expressed in this limited warranty shall apply and no dealer, distributor, or individual is authorized to amend, modify, or extend this warranty in any way. Accordingly, additional statements such as dealer advertising or presentations, whether oral or written, do not constitute warranties by Walker, and should not be relied upon.
- D. This warranty gives you specific legal rights, and you may also have other rights which vary from state to state.

WALKER MOWERS™

WALKER MFG. CO. • 5925 E. HARMONY ROAD, FORT COLLINS, CO 80528 • (970) 221-5614
FORM NO. 040903 PRINTED IN USA ©2003 WALKER MFG. CO
www.walkermowers.com