

# WALKER

## Illustrated Parts Manual

# S14



Beginning S/N: 128442  
Effective Date: 05.05.14  
P/N 5000-27

# KEY TO ABBREVIATIONS USED IN THIS MANUAL

<i>Abbreviation</i>	<i>What it Represents</i>
° (Dimension)	Degrees (Angle)
" (Dimension)	inches
(-)	Negative (Polarity)
(+)	Positive (Polarity)
AT	All-Terrain
CCW	Counter-clockwise
Conn	Connector
CW	Clockwise
D	Diameter
DC	Deck, Collection (number refers to size in inches)
DM	Deck, Mulching (number refers to size in inches)
DR	Deck, Rear Discharge (number refers to size in inches)
DS	Deck, Side Discharge (number refers to size in inches)
DU	Garlock (Bearing)
ESNA (Fastener)	Nylon Insert Locknut
FSC	Forward Speed Control
GA	Gauge
gal	gallon
GHS	Grass Handling System
GR (Fastener)	Grade
HD	Heavy Duty
HP	Horse Power
ID	Identification or Inside Diameter
L	Length
LH	Left Hand (orientated with operator on seat)
LP	Low Profile
mm (Dimension)	millimeters
MS (Fastener)	Machine Screw
NS (as part number)	Item is not sold by Walker Manufacturing
OD	Outside Diameter
oz	ounce
PFH (Fastener)	Phillips Flat Head
P/N	Part Number
PPH (Fastener)	Phillips Pan Head
PTH (Fastener)	Phillips Truss Head
PTO	Power Take-Off
QKS	Quick Slide
qt	quart
RH	Right Hand (orientated with operator on seat)
SAE (Fastener)	Society of Automotive Engineers
SBH (Fastener)	Socket Button Head (Bolt)
SD	Side Discharge
SFH (Fastener)	Slotted Flat Head
SHC (Fastener)	Socket Head Cap
SHL (Fastener)	Shoulder (Bolt)
SM (Fastener)	Sheet Metal (Screw)
S/N	Serial Number
Spg	Spring
SQH (Fastener)	Square Head
SS (Fastener)	Stainless Steel
ST (Fastener)	Self-Tapping (Screw)
Term	Terminal
V	Volts

**NOTE:** In some instances, combinations of abbreviations may be used (e.g. PPHMS - Phillips Pan Head Machine Screw).

Beginning S/N 128442

Effective Date 05-05-14

Use only genuine **Walker**<sup>®</sup> replacement parts.

# ILLUSTRATED PARTS LIST

<i>Section of Tractor Covered</i>	<i>Page</i>	<i>Section of Tractor Covered</i>	<i>Page</i>
<hr/>		<hr/>	
<b>Decals</b>		<b>Electrical Components</b>	
Tractor Decals .....	2	Electrical Assembly .....	22
<b>Body / Chassis Assemblies</b>		Electrical Assemblies (GHS 7.0 Bushel Components).....	24
Body / Chassis Assembly .....	4	Electrical Connectors.....	26
Rear Body Assembly.....	6	<b>Maintenance</b>	
<b>Tractor Components</b>		Lubrication Points .....	28
Main Component Power Transmission .....	8	Wiring Schematic .....	30
Engine Group .....	10	<b>Operator's Notes</b> .....	31
Hydrostatic Ground Drive Assemblies.....	12	<b>Warranty</b>	
Steering Control Assemblies.....	14	Limited Warranty .....	33
GHS Group .....	16		
GHS Powerfil® Assembly (7.0) .....	18		
GHS 7.0 Bushel Catcher Assembly.....	20		

# TRACTOR DECALS

ITEM NO.	PART NO.	DESCRIPTION	LOCATION	NO. REQ'D GHS
<b>Walker Product Decals</b>				
1	5800-11	Walker (8" Round)	7.0 Bushel Catcher (one on each side)	2
2	9804-1	Axle Lockout	Chassis	2
3	8600-27	LH Fender	Body, LH near Seat	1
4	8821-7	Decal, S14	Body	1
5	5856-1	Made in USA	Body	1
6	8600-26	RH Fender	Body, RH near Seat	1
<b>Danger Decals Warning Decals Caution Decals</b>				
7	8600-10	Danger, Pinch Point	7.0 Bushel Catcher Mounting Frame Assembly (one on each side)	2
8	8600-12	Danger, Engine Exhaust	Engine	1
9	8600-4	Danger, Rotating Blower Blades	Body, Near Body Chute	1
<b>Maintenance Decals</b>				
10	5869	Removable Screen	7.0 Bushel Catcher Removable Screen	1
11	5855	Important, Engine Cooling	Engine	1
12	5082-5	Fuel Recommendations	Engine	1
13	4024-2	Oil Reservoir	Reservoir Cap (one on each)	2
14	6875	PTO Alignment Arrow	Universal Joint Tube Assembly	1

**NOTE:** All parts requiring decals are shipped with decals applied.

# TRACTOR DECALS

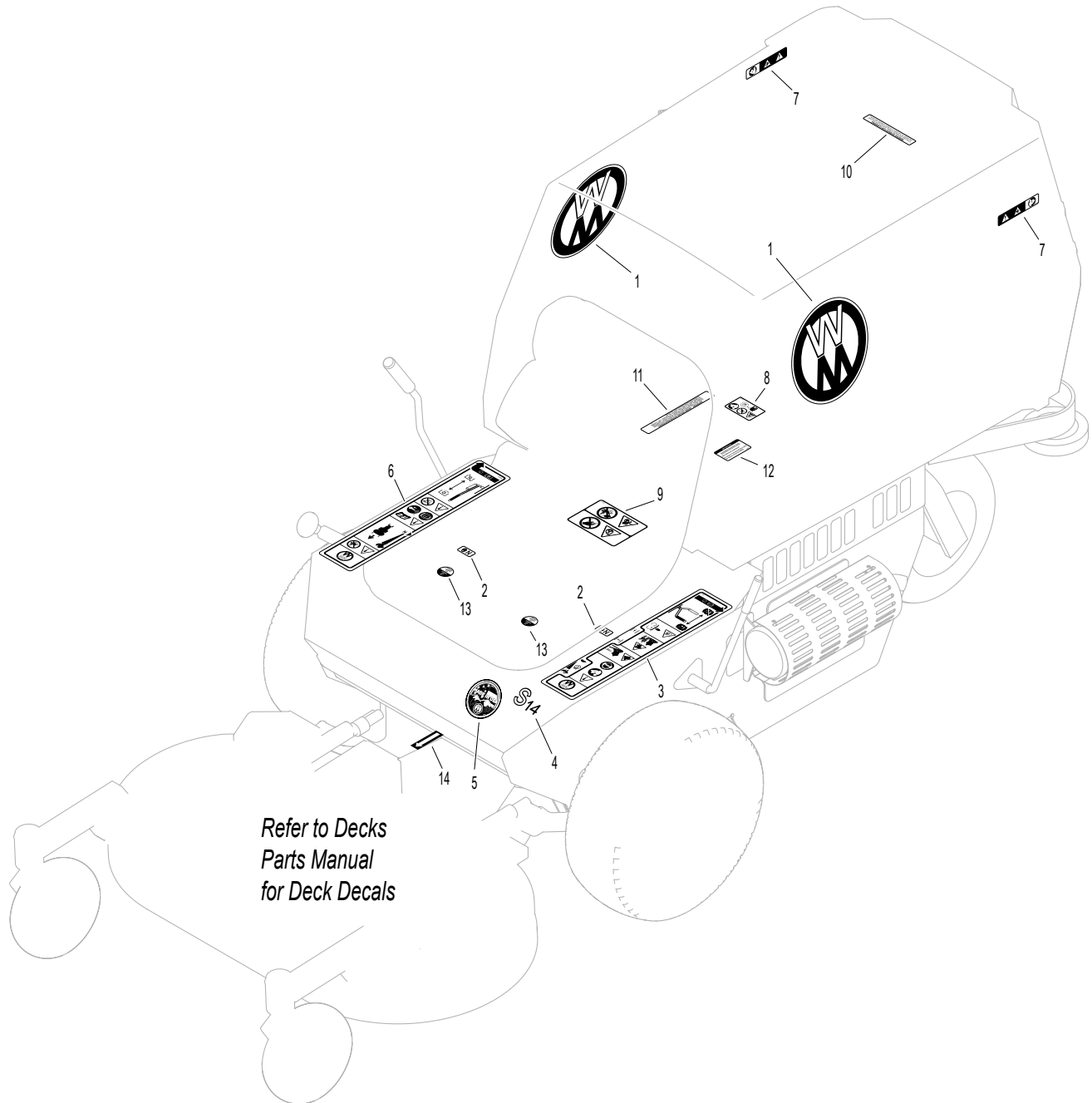

# BODY / CHASSIS ASSEMBLY

ITEM NO.	PART NO.	DESCRIPTION	NO. REQ'D	ITEM NO.	PART NO.	DESCRIPTION	NO. REQ'D
<b>Seat Assembly</b>				<b>Deck Support Arm &amp; Hitch Assemblies</b>			
1	5103	Seat	1	40	5830	Grease Fitting	2
2	7223-1	Compression Spring	2	41	6840-1	Support Arm Bushing (2-1/16)	2
3	5841-1	Retainer Washer	4	42	6431-5	Deck Arm Mount	2
4	7434	Washer (3/8 x 1-1/4 x 1/4)	2	43	6431-3	Deck Support Arm, LH (Includes Item # 40)	1
5	7845-1	Rubber Bumper (1.375 x .750)	2	44	2775	Lynch Pin (5/16 x 1-1/4)	2
6	7440-5	Shock Mount (1-1/4 x 3/4)	2	45	5303-5	Deck Arm Hydro Mount, LH	1
<b>Rear Bumper Assembly</b>				46	5303-6	Deck Arm Hydro Mount, RH	1
7	7516-5	Catcher Pivot Bushing	2	47	6431-4	Deck Support Arm, RH (Includes Item # 40)	1
8	5517-6	Rear Bumper	1	<b>Fasteners</b>			
9	7517-2	Catcher Pivot Plate	2	F002	10-24 Keps Nut		12
10	5162	Roller Wheel (5" Rubber)	2	F004	1/4-20 Keps Nut		6
<b>Body Assembly</b>				F005	1/4-20 ESNA Nut		1
11	2505	Leaf Spring	1	F009	5/16-18 Whiz Locknut		22
12	5100-10	Welded Body	1	F012	3/8-16 Keps Nut		2
13	4102-1	Body Guide, Upper	1	F013	3/8-16 Whiz Locknut		4
14	7844	Rubber Bumper (1.25 x .250)	2	F014	3/8-16 ESNA Nut		2
15	NS	Body ID Plate	1	F016	1/2-13 Self-Locking Nut		1
16	5180	Edge Molding, Lever Opening	2	F020	5/16-18 ESNA Nut		1
17	4504-3	Hinge (19")	1	F025	10-24 x 3/8 PPHMS		2
<b>Tilt-Up Latch Assembly**</b>				F028	10-24 x 3/4 PPHMS		1
18	5847	Plastic Tip	1	F029	1/4-20 x 1/2 Hex Bolt		4
19	5744-20	Spring Arm, Tilt-Up Latch	1	F031	1/4-20 x 5/8 Hex Bolt		8
20	5744-10	Spring Pivot Bushing	1	F034	5/16-18 x 3/4 Hex Bolt		8
21	5744-15	Compression Spring (3/8 x 5/8)	1	F042	3/8-16 x 2-1/4 Hex Bolt		2
22	5744-13	Mount Angle, LH	1	F048	1/2 SAE Washer		2
23	5744-12	Hook, Tilt-Up Latch	1	F049	5/16 SAE Washer		8
24	5744-14	Mount Angle, RH	1	F053	7/16 Int. Star Lock Washer		2
<b>Chassis Assembly</b>				F059	3/8 Wave Spring Washer		2
25	5300-2	Chassis Side Cover, RH	1	F093	5/16-18 x 1 Hex Bolt		1
26	5300-10	Chassis Frame	1	F116	1/4-20 x 1-1/4 Hex Bolt		1
27	5267-1	Retainer Collar (1") (Includes Item # F413)	1	F151	3/8-16 x 7/8 Hex Bolt		2
28	5270-1	Pivot Bearing	2	F183	.312 x .700 x .074 Washer		2
29	5420-2	Tail Wheel Fork	1	F200	7/16-20 x 3 Grade 8 Bolt		2
30	5037-1	Bearing, Tail Wheel	2	F206	#2 x 3/16 Drive Pin		2
31	5035	Tail Wheel & Tire Assembly (13 x 6.50-6)	1	F227	3/8 x 1-1/4 x 1/8 Washer		2
	5035-1	Tail Wheel Tire (13 x 6.50-6)	*	F241	.375 x .875 x .10 Washer		4
	5036	Tail Wheel & Hub (6 x 4.5)	*	F246	1/4-20 x 1/2 PTHMS		8
32	5038-1	Axle Spacer Tube (6-5/8)	1	F257	3/8 x 1-11/16 Shoulder Bolt		2
33	5300-1	Chassis Side Cover, LH	1	F292	1/2-13 x 8-1/2 Hex Bolt, GR 2		1
34	5146	10mm Ball Stud	2	F341	Coil Roll Pin (7/64 x 9/16)		1
35	5145-4	Gas Spring Assembly (Includes Item # 34)	1	F342	5/16 Conical Washer		2
36	7383-1	Body Latch Hook	1	F413	5/16-24 x 5/16 Set Screw		2
37	7854	Plastic Tip, Red	1	F438	5/16-18 x 2-3/4 Hex Bolt		4
38	7222	Extension Spring (1/4 x 3)	1	F477	1/4-20 x 5/8 Carriage Bolt		2
39	4102-2	Body Guide, Lower	1	* Service Part Only			
				** Complete Tilt-Up Latch Assembly Kit available by ordering kit # 5747.			

Beginning S/N 128442

Effective Date 05-05-14

Use only genuine **Walker**® replacement parts.

# BODY / CHASSIS ASSEMBLY

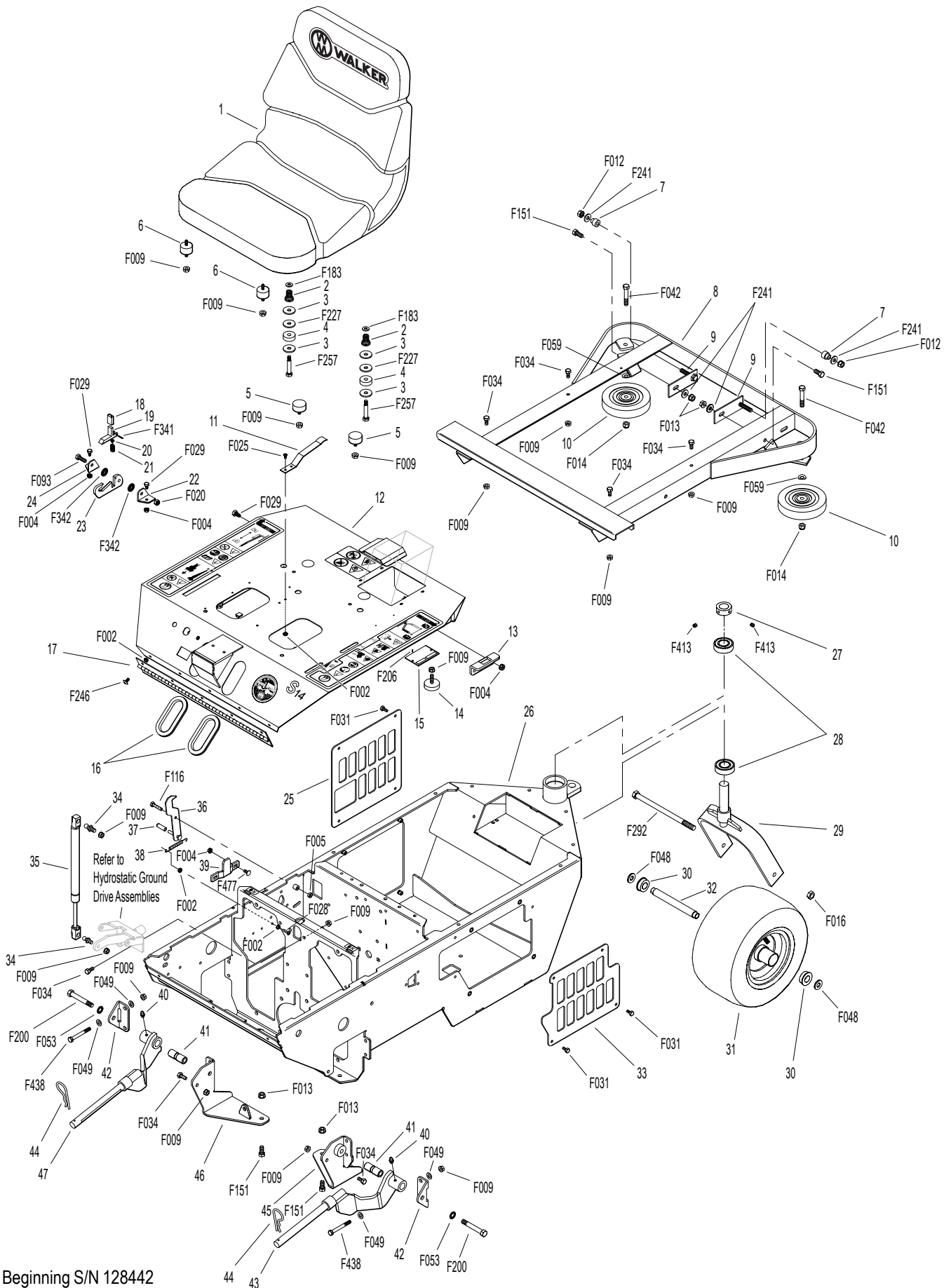

Beginning S/N 128442  
 Effective Date 05-05-14  
 Use only genuine Walker® replacement parts.

# REAR BODY ASSEMBLY

ITEM NO.	PART NO.	DESCRIPTION	NO. REQ'D	ITEM NO.	PART NO.	DESCRIPTION	NO. REQ'D
<b>Rear Body Assembly</b>				<b>Fasteners</b>			
1	6515	Catcher Support Frame	1		F002	10-24 Keps Nut	4
2	5977-6	Grommet (1 x 1-1/4)	2		F004	1/4-20 Keps Nut	5
3	5100-9	Rear Body Tie-In	1		F009	5/16-18 Whiz Locknut	10
4	5100-1	Rear Body Panel, LH	1		F025	10-24 x 3/8 PPHMS	4
5	5100-26	Rear Body Panel, RH	1		F031	1/4-20 x 5/8 Hex Bolt	3
6	8515-14	Catcher Handle Plate, RH	1		F034	5/16-18 x 3/4 Hex Bolt	8
7	8515-13	Catcher Handle Plate, LH	1		F390	1/4-20 x 7/8 Carriage Bolt	2
8	7147	Spring Clip	2				
9	7146	13mm Ball Stud	2				
10	7145	Gas Spring Assembly (Includes Items # 8 & 9)	1				
						<b>NOTE:</b> Rear Bumper Assembly for GHS Models is not shown here. Refer to <b>BODY / CHASSIS ASSEMBLY</b> , Page 4.	



# REAR BODY ASSEMBLY

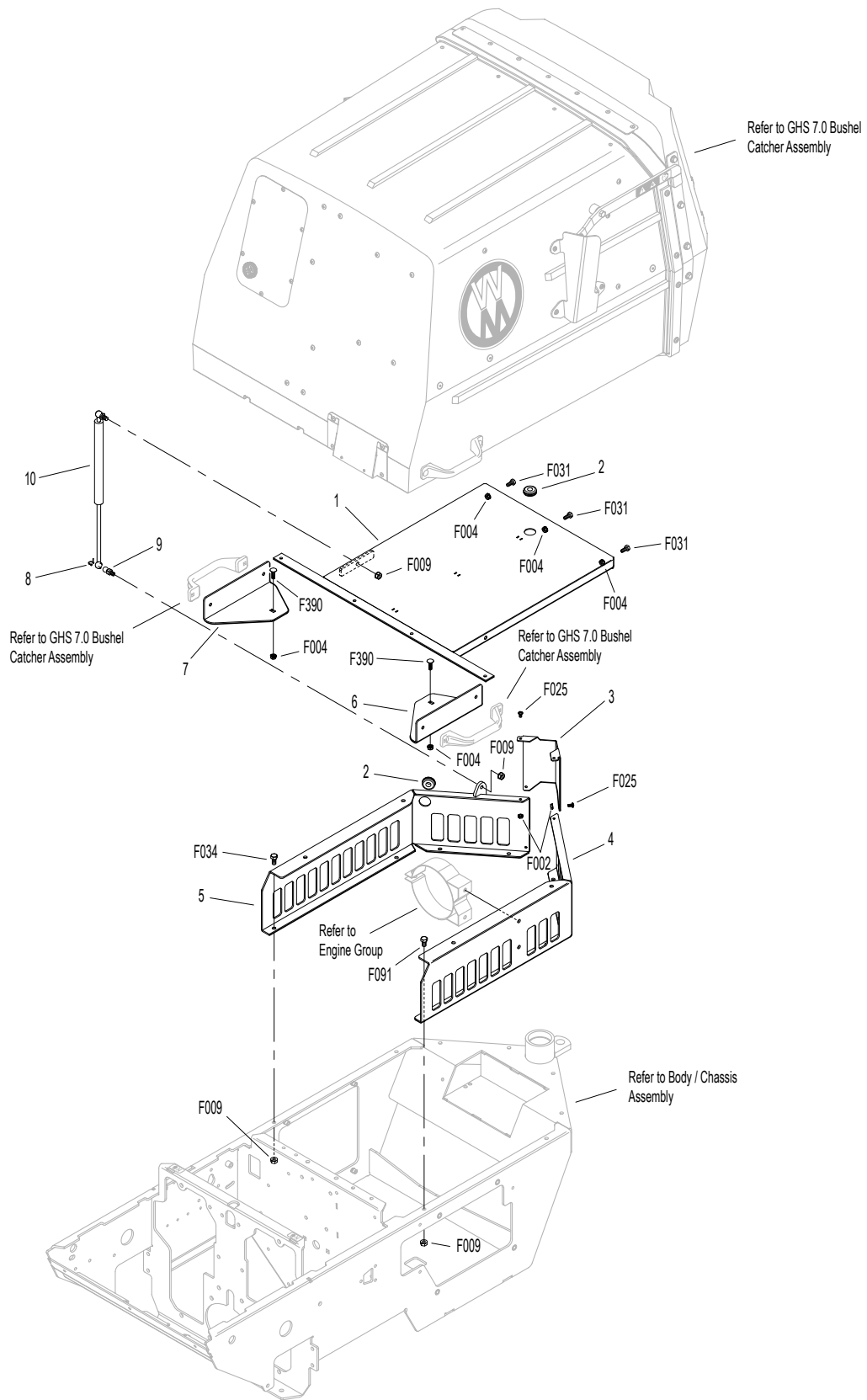

Beginning S/N 128442  
Effective Date 05-05-14  
Use only genuine **Walker**® replacement parts.

# MAIN COMPONENT POWER TRANSMISSION

ITEM NO.	PART NO.	DESCRIPTION	NO. REQ'D	ITEM NO.	PART NO.	DESCRIPTION	NO. REQ'D
<b>PTO Drive Assembly</b>				<b>Blower Brake Assembly</b>			
1	4850	Handle Grip, Black	1	37	7523-2	Clevis Pin W/Hole (1/4 x 5/8)	1
2	6358-29	Clutch Lever	1	38	8304	Brake Band (14-1/2)	1
3	5830	Grease Fitting	2	39	4359-1	Brake Band Link, Front	2
4	4303-7	Clutch Actuator Bolt (5/16)	1	<b>Fasteners</b>			
5	7380	Knuckle Joint	1				
6	5830-4	Grease Fitting (90 Degree)	1	F004	1/4-20 Keps Nut		8
7	2358-6	5/16-18 x 1-3/4 Stud	2	F005	1/4-20 ESNA Nut		1
8	5103-2	Pivot Bushing (5/16 ID)	2	F008	5/16-24 Keps Nut		2
9	6325-5	Clutch Arm	1	F009	5/16-18 Whiz Locknut		10
10	7377	Plastic Washer (1 x .438 x .025)	2	F010	5/16-24 ESNA Nut		1
11	7378	Pivot Bearing (7/16 x 9/16)	1	F012	3/8-16 Keps Nut		1
12	5214-3	Ball Joint (5/16-24LH) (Nylon Lined)	1	F024	5/16-24 Jam Nut		2
13	6325-6	Clutch Arm Support Bracket	1	F029	1/4-20 x 1/2 Hex Bolt		1
14	6410-3	Clutch Pull Rod 8-5/8	1	F031	1/4-20 x 5/8 Hex Bolt		6
15	5214-2	Ball Joint (5/16-24) (Nylon Lined)	1	F034	5/16-18 x 3/4 Hex Bolt		5
16	5221	Extension Spring (3/4 x 4)	1	F035	5/16-18 x 1-1/4 Hex Bolt		1
17	5214-4	Ball Joint (5/16-24) W/O Stud	1	F040	3/8-16 x 1-1/2 Hex Bolt		2
18	5226-1	Spring (3/4 x 2-1/2)	1	F049	5/16 SAE Washer		1
19	5247-2	V-Groove Idler (4")	2	F050	1/4 SAE Washer		3
20	5234-4	PTO Drive Belt	1	F054	AN960616 Washer		2
21	5238-4	PTO Drive Pulley (5/B) (Includes Items # F067 & F171)	1	F060	AN960516 Washer		2
22	5830-3	Grease Fitting (45 Degree)	1	F061	1/4 Star Lock Washer		1
23	6358-4	PTO / Clutch / Brake Actuator (Includes Items # 22 & 25)	1	F063	3/8 Int. Star Lock Washer		2
24	6358-3	PTO / Clutch / Brake Support	1	F067	3/16 x 3/16 x 1 Key		1
25	7201-3	Fiberglide Bearing	2	F069	3/32 x 1/2 Cotter Pin		1
26	7201-5	Inner Race (2-1/4)	1	F106	3/8-16 x 5/8 Hex Bolt		2
27	5303-3	Belt Guide Mount	1	F116	1/4-20 x 1-1/4 Hex Bolt		1
<b>Engine Belt Tightener Assembly</b>				F135	3/16 x 3/16 x 1-3/4 Key		1
28	5240-1	Compound Pulley, 4/B (Includes Items # F135 & F171)	1	F171	5/16-18 x 3/8 Set Screw		6
29	5234-3	Engine Drive Belt	1	F178	1/4 x 1 Fender Washer		1
30	5495-28	Engine Idler Arm (Includes Item # 3)	1	F179	1/4-20 x 1 Hex Bolt		1
31	5103-8	Bushing .500 x .3125 x 1.655-.660	1	F183	.312 x .700 x .074 Washer		1
32	5221-1	Extension Spring (3/4 x 5)	1	F241	.375 x .875 x .10 Washer		1
33	5237-2	Engine Pulley (4-1/4B) (Includes Items # F066 & F171)	1	F350	1/4-20 LP Nylock		1
34	5268	Bearing W/Collar (3/4)	2	F373	5/16-24 Hex Nut, LH		1
35	6394-1	Jackshaft Bearing Housing	1	F393	3/8-16 x 3-1/4 Hex Bolt		1
36	6273-1	Jackshaft (3/4 x 11.750)	1	F447	1/4 x 1/4 x 1 Key		1
				F535	5/16-24 x 2-1/2 Hex Bolt		1

Beginning S/N 128442

Effective Date 05-05-14

Use only genuine **Walker**® replacement parts.

# MAIN COMPONENT POWER TRANSMISSION

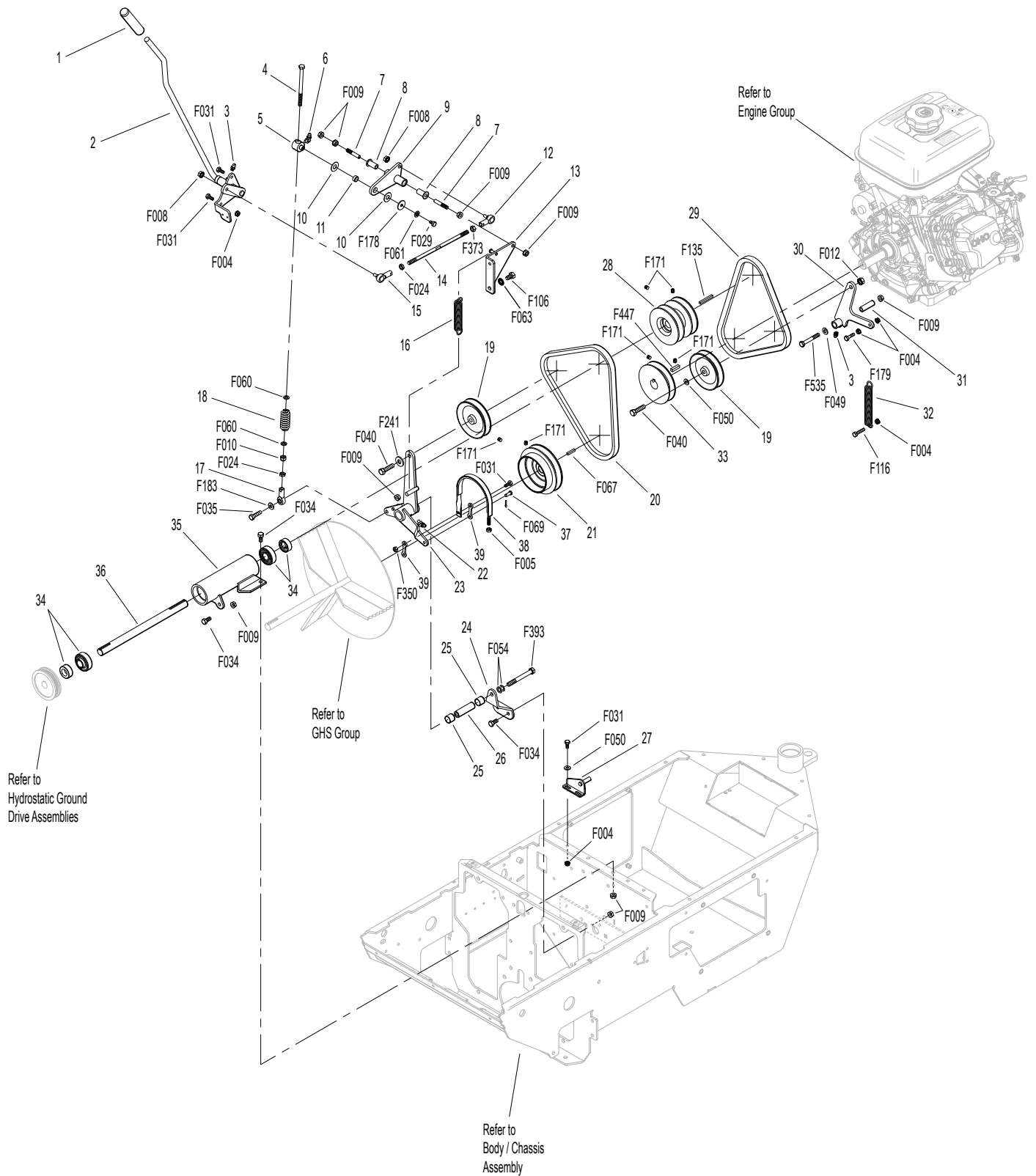

Beginning S/N 128442  
 Effective Date 05-05-14  
 Use only genuine **Walker**® replacement parts.

# ENGINE GROUP

ITEM NO.	PART NO.	DESCRIPTION	NO. REQ'D	ITEM NO.	PART NO.	DESCRIPTION	NO. REQ'D
<b>Engine Assembly</b>				<b>Fasteners</b>			
1	5303-4	Engine Brace	1	F002		10-24 Keps Nut	6
2	NS	14 HP Engine (Subaru)	1	F004		1/4-20 Keps Nut	3
3	6090-11	Air Cleaner Assembly (Includes Items # 3-5)	1	F005		1/4-20 ESNA Nut	2
4	5090-1	Air Cleaner Cartridge	1	F009		5/16-18 Whiz Locknut	5
5	5090-3	Safety Filter Insert	1	F013		3/8-16 Whiz Locknut	4
6	5088-1	Air Cleaner Band	1	F025		10-24 x 3/8 PPHMS	4
7	7840	Hose Clamp (1-1/4 to 1-3/4)	2	F034		5/16-18 x 3/4 Hex Bolt	3
8	5011-8	Air Intake Hose	1	F040		3/8-16 x 1-1/2 Hex Bolt	4
9	5879-3	Hose Clamp (1/2)	3	F044		5/16-24 x 3/4 Hex Bolt	2
10	5011-9	90 Degree Elbow 5/16"	1	F050		1/4 SAE Washer	4
11	M247	Fuel Line (5/16 x 1")	1**	F051		3/8 SAE Washer	4
12	5011-11	Intake Tube	1	F052		5/16 Ext. Star Lock Washer	2
13	M247	Fuel Line (5/16 x 6")	1**	F164		10-24 x 1/4 x 3/8 SHL Bolt	2
14	5011-12	Intake Pipe / Gasket	1	F184		1/4-20 x 1/2 Hex Bolt, SS	4
15	5303-7	Engine Spacer	1	F185		1/4 Internal Star Lock Washer, SS	4
<b>Exhaust Assembly</b>				F201		1/4 Belleville Spring Washer	4
16	NS	Nut	2	F211		1/4-20 x 7/8 Hex Bolt	3
17	NS	Gasket, Muffler	1	F539		Washer .281 x .750 x .185	3
18	5011-15	Muffler	1	* Service Part Only			
19	5013-3	Muffler Heat Shield	1	** <b>Required hose specifications:</b>			
<b>Throttle and Choke Assemblies</b>				M247 – 5/16" ID low permeation (<15g/m <sup>2</sup> /day) fuel hose (Parker 38905 or equivalent)			
20	8108-4	Throttle Cable	1				
21	5122-3	Choke Cable	1				
22	5108-1	Control Lever, Throttle and Choke	2				
23	5108-5	Throttle Control Knob, Red	1				
24	5108-6	Choke Control Knob, Black	1				
25	7108	Control Assembly, Throttle and Choke (Includes Items # 22, 26-28 & F201)	*				
	2108-2	Throttle Control and Cable Assembly (Complete Control and Cable Assembly)	*				
	5121-3	Choke Control and Cable Assembly (Complete Control and Cable Assembly)	*				
26	5108-8	Control Bracket	2				
27	5108-10	Friction Washer (.125)	2				
28	5108-7	Control Lock Tab	2				
29	5172	Bearing, Nylon (.255 x .379 x .250)	2				

# ENGINE GROUP

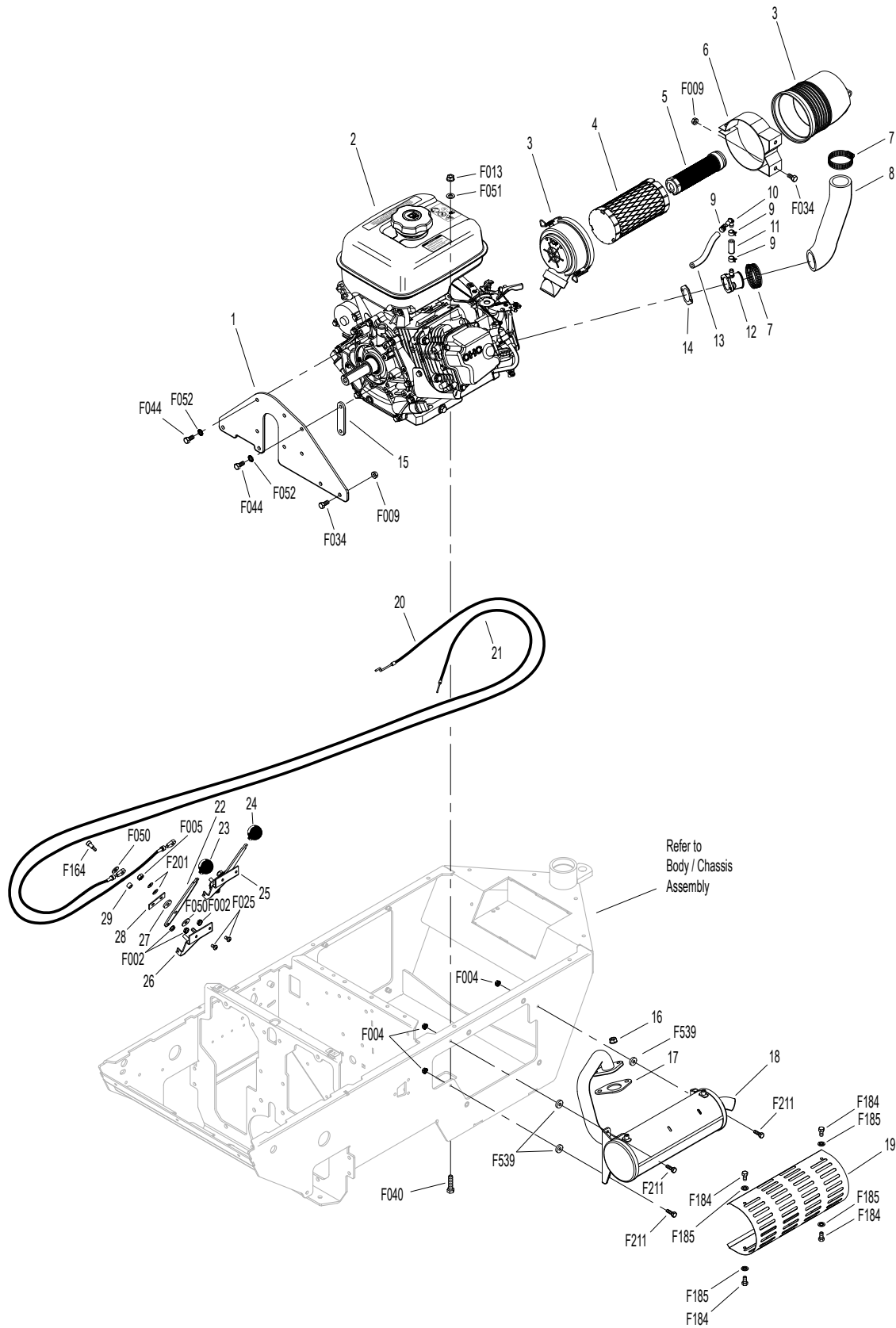

Beginning S/N 128442  
Effective Date 05-05-14  
Use only genuine **Walker**® replacement parts.

# HYDROSTATIC GROUND DRIVE ASSEMBLIES

ITEM NO.	PART NO.	DESCRIPTION	NO. REQ'D	ITEM NO.	PART NO.	DESCRIPTION	NO. REQ'D	
<b>Ground Drive Assemblies</b>				<b>Wheel Assembly</b>				
1	4024-5	Oil Expansion Reservoir	2	37	5033-6	Wheel & Tire (18 x 7.00-8)	2	
2	7840-4	Hose Clamp (3/4 to 1-1/2)	2		5030-6	Standard Tire (18 x 7.00-8)	*	
3	4024-7	O-Ring (15/16 x 1-1/8)	2		5031-2	Standard Wheel (8 x 5.00-5.00)	*	
4	6024-1	Oil Reservoir Retainer	2		5030-4	Tire Tube (18 x 8.50-8)	*	
5	4024-15	O-Ring (3/8 x 1/2)	2	<b>Fasteners</b>				
6	5026-14	Hydro-Gear ZT3100, RH	1		F004	1/4-20 Keps Nut	3	
7	2028-6	Lockout Arm, RH	1		F009	5/16-18 Whiz Locknut	9	
8	4407-4	Bow Tie Cotter Pin	3		F013	3/8-16 Whiz Locknut	4	
9	7364-3	Idler Spring Bushing	1		F015	1/2-20 Wheel Lug Nut	8	
10	7364-2	Torsion Spring	1		F020	5/16-18 ESNA Nut	2	
11	6345-4	Idler Arm	1		F029	1/4-20 x 1/2 Hex Bolt	1	
12	5025-18	Hydro Fan Washer	2		F031	1/4-20 x 5/8 Hex Bolt	3	
13	5025-17	Hydro Fan	2		F034	5/16-18 x 3/4 Hex Bolt	2	
14	7244-21	Hydro Pulley (4.075) Splined	2		F041	3/8-16 x 1-3/4 Hex Bolt	1	
15	5025-19	Hydro Fan Nut	2		F042	3/8-16 x 2-1/4 Hex Bolt	2	
16	7241-2	Transmission Drive Pulley (3-1/4MV) (Includes Items # F067 & F171)	1		F067	3/16 x 3/16 x 1 Key	1	
17	5232-1	Ground Drive Belt (Micro V)	1		F069	3/32 x 1/2 Cotter Pin	5	
18	5245-1	Idler Pulley	1		F129	10-24 x 1/2 PTHMS	2	
19	6325-2	Spacer Bushing (5/16)	1		F171	5/16-18 x 3/8 Set Screw	2	
20	2028-5	Lockout Arm, LH	1		F182	1/4 x 5/8 x 1/8 Washer	2	
21	5025-14	Hydro-Gear ZT3100, LH	1		F183	.312 x .700 x .074 Washer	3	
22	9430-1	Spacer Tube	4		F316	5/16-18 x 1-3/4 Hex Bolt	1	
23	6215	Shock Mount / Body Lift Arm (Includes Item # 24)	1		F336	3/8-16 Jam Nut	1	
24	5830	Grease Fitting	2		F388	3/8-16 x 2-1/2 Hex Bolt	2	
<b>Parking Brake Assembly</b>						F489	Washer 1/4 x 7/8 x .090	1
25	7406-1	Handle Grip, Red	1		F529	Washer 1.0 OD x .515 ID x 1/8	2	
26	6406-6	Parking Brake Lever (Includes Item # 24)	1		F533	5/16-18 x 3-1/2 Socket Cap Bolt	4	
27	6406-1	Brake Actuator Pull	1	* Service Part Only				
28	2280	Clevis (3/8)	1					
29	6406-2	Parking Brake Pull Rod	2					
30	8655-4	Clevis Pin (5/16 x 3/4)	5					
31	6406-4	Parking Brake Pull Mount, Inner	2					
32	6406-5	Parking Brake Pull Mount, Outer	2					
33	5665-1	Compression Spring (2-1/2)	2					
34	5222	Extension Spring (1/2 x 3-1/4)	2					
35	6406-3	Parking Brake Actuator	1					
36	2406-4	Clevis Pin (5/16 x 1-1/8)	1					

# HYDROSTATIC GROUND DRIVE ASSEMBLIES

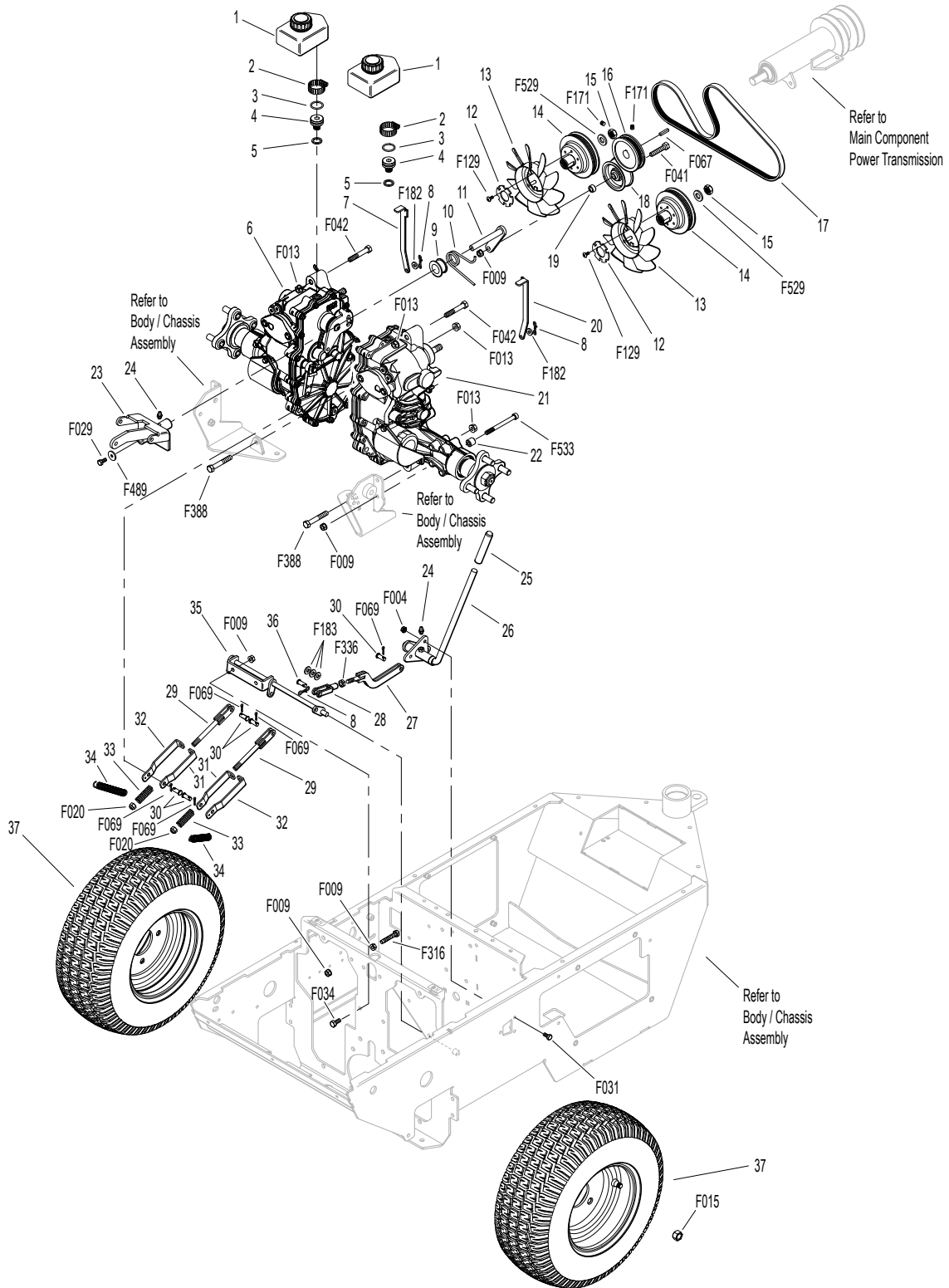

Beginning S/N 128442  
 Effective Date 05-05-14  
 Use only genuine **Walker**® replacement parts.

# STEERING CONTROL ASSEMBLIES

ITEM NO.	PART NO.	DESCRIPTION	NO. REQ'D	ITEM NO.	PART NO.	DESCRIPTION	NO. REQ'D
<b>Steering Lever &amp; FSC Assemblies</b>				<b>Fasteners</b>			
1	5862	FSC Knob	1	F004		1/4-20 Keps Nut	2
2	4170	FSC Lever Assembly (Includes Item # 4)	*	F005		1/4-20 ESNA Nut	2
3	2170-1	Step Washer	1	F009		5/16-18 Whiz Locknut	6
4	5830	Grease Fitting	1	F010		5/16-24 ESNA Nut	2
5	5214-5	Ball Joint (5/16-24/LH) W/O Stud	1	F024		5/16-24 Jam Nut	3
6	4173-1	Control Rod (4-15/16)	1	F035		5/16-18 x 1-1/4 Hex Bolt	1
7	5214	Ball Joint (5/16-24)	1	F044		5/16-24 x 3/4 Hex Bolt	2
8	4219	Extension Spring (3/4 x 6-1/2)	1	F059		3/8 Wave Spring Washer	1
9	4451-9	FSC Friction Actuator	1	F093		5/16-18 x 1 Hex Bolt	2
10	8201-3	Fiberglide Bearing	4	F146		1/4-20 Jam Nut	2
11	6451-2	Speed Control Actuator, RH (Includes Items # 10 & 13)	1	F167		5/16-18 Hex Nut	1
12	4452-6	Steering Pivot (1/4-20 x 1-5/8)	2	F183		.312 x .700 x .074 Washer	6
13	5830-3	Grease Fitting (45 Degree)	2	F188		1/4-20 Self-Locking Nut	4
14	5146	10mm Ball Stud	4	F192		3/8-24 Self-Locking Nut	1
15	2215-7	Steering Lever Spring, Dampener	2	F198		.250 x .625 x .040 Washer, SS	2
16	2463	Actuator Washer	2	F211		1/4-20 x 7/8 Hex Bolt	1
17	7201-2	Fiberglide Bearing (1/2")	2	F312		3/8 x 3/8 Shoulder Bolt	1
18	5463-2	Steering Lever Actuator	2	F345		1/4-20 x .770 Knurled Bolt	4
19	5665-1	Compression Spring (2-1/2)	2	F360		1/4-20 x 3/8 Hex Bolt	2
20	4213-2	Control Rod (6-1/2)	2	F373		5/16-24 Hex Nut, LH	1
21	5214-4	Ball Joint (5/16-24) W/O Stud	2	F385		1/4 x 1-1/4 Roll Pin	1
22	2212-3	Seal Retainer	2	F386		5/16-18 x 1-1/2 x 3/8 Shoulder Bolt	1
23	2212	Transmission Control Arm Stop	2	F391		1/4-20 x 1/2 Set Screw, SS	2
24	6212-2	Transmission Control Arm, RH	1	F407		Belleville Washer 3/8 x 1.187, SS	1
25	6212-3	Transmission Control Arm, LH	1	F427		5/16-18 Flange Nut	1
26	6451-1	Speed Control Actuator, LH (Includes Items # 10 & 13)	1	* Service Part Only			
27	4451-1	Steering Pivot Shaft W/Stop	1				
28	9704-3	Pivot Rod Bushing / Plastic	2				
29	4142-2	FSC Friction Washer (1-1/2 x 1-1/32 x 1/16)	1				
30	5141	FSC Friction Washer (1-1/2 x 3/8 x 1/16)	1				
31	4142-1	FSC Cam	1				
32	5222	Extension Spring (1/2 x 3-1/4)	2				
33	5450	D-Clip	2				
34	6452-1	Steering Lever Tube W/Tab	2				
35	5453-10	Steering Lever Handle / Adjustable (Includes Items # 36 & F345)	2				
36	5850-2	Handle Grip, Foam (5-1/2)	2				



# STEERING CONTROL ASSEMBLIES

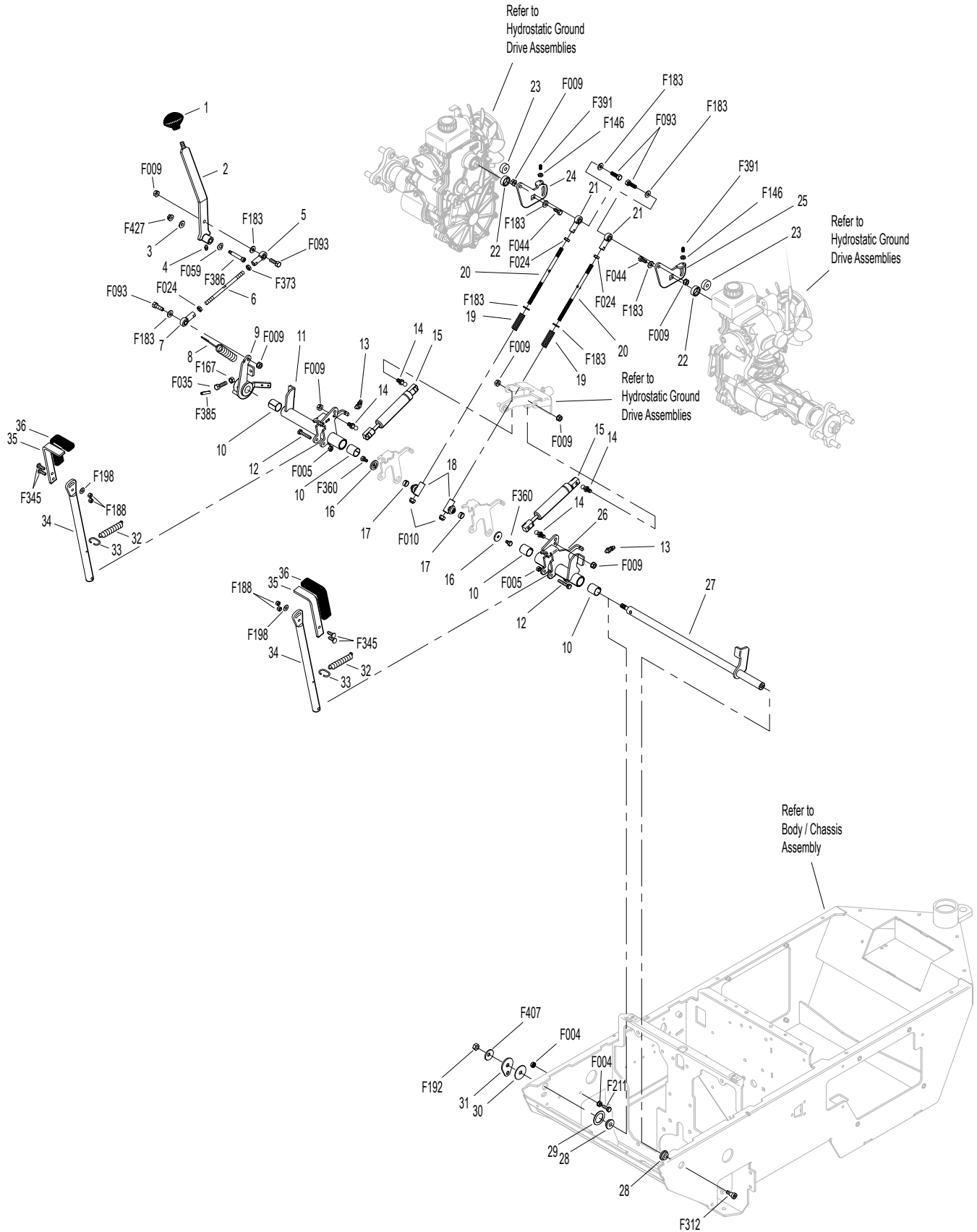

Beginning S/N 128442  
 Effective Date 05-05-14  
 Use only genuine **Walker**® replacement parts.

# GHS GROUP

ITEM NO.	PART NO.	DESCRIPTION	NO. REQ'D	ITEM NO.	PART NO.	DESCRIPTION	NO. REQ'D
<b>Delivery Chute Assembly</b>				<b>Fasteners</b>			
1	5515-2	Elbow Delivery Spout	1	F002		10-24 Keps Nut	6
2	5592-13	Backing Plate, Grass-Pak® Switch	1	F004		1/4-20 Keps Nut	18
3	5578	Rear Clip, Chute Mount	1	F009		5/16-18 Whiz Locknut	2
4	5577	Side Clip, Chute Mount	2	F013		3/8-16 Whiz Locknut	2
5	6530-6	Body Chute	1	F025		10-24 x 3/8 PPHMS	4
6	7511-5	Outside Chute Cover Lip	1	F026		10-24 x 1/2 PPHMS	2
7	7511-4	Inside Chute Cover Lip	1	F031		1/4-20 x 5/8 Hex Bolt	2
8	7511-2	7.0 Delivery Chute W/Clips (Includes Items # 3, 4, F079 & F411)	1	F032		1/4-20 x 3/4 Hex Bolt	4
				F038		3/8-16 x 1 Hex Bolt	2
				F050		1/4 SAE Washer	2
				F067		3/16 x 3/16 x 1 Key	1
				F076		3/8-16 x 5/8 SQH Set Screw	1
				F079		A/A66D Aluminum Pop Rivet	14
				F169		5/16-18 x 1 Carriage Bolt	2
				F411		3/16 Bulbex Rivet	6
				F426		1/4-20 x 1/2 Carriage Bolt	4
				F531		1/4-20 x 5 Hex Bolt	11
				F532		1/4-20 x 5-1/2 Hex Bolt	1
<b>Blower Assembly</b>				<b>NOTE:</b> Refer to <b>ELECTRICAL CONNECTORS</b> , Page 26, for identification of all Electrical Wiring Service Parts.			
9	6543-5	Blower Scroll	1				
10	4349-10	Flanged Bearing (3/4")	2				
11	6349-1	Sleeve .3150 x .375 x 3/8	2				
12	5526-9	Receiver Cone	1				
13	5275-15	U-Joint Tube/9.5" OAL Spline (Includes Item # F076)	1				
14	6545-1	Blower Wheel	1				
15	6543-4	Blower Faceplate	1				
16	6543-6	Blower Ring	1				
17	5794-4	Fixed Chute (Includes Items # 18, 19 & F079)	1				
18	5794-10	Rubber Flap	2				
19	5794-9	Backing Plate	2				

# GHS GROUP

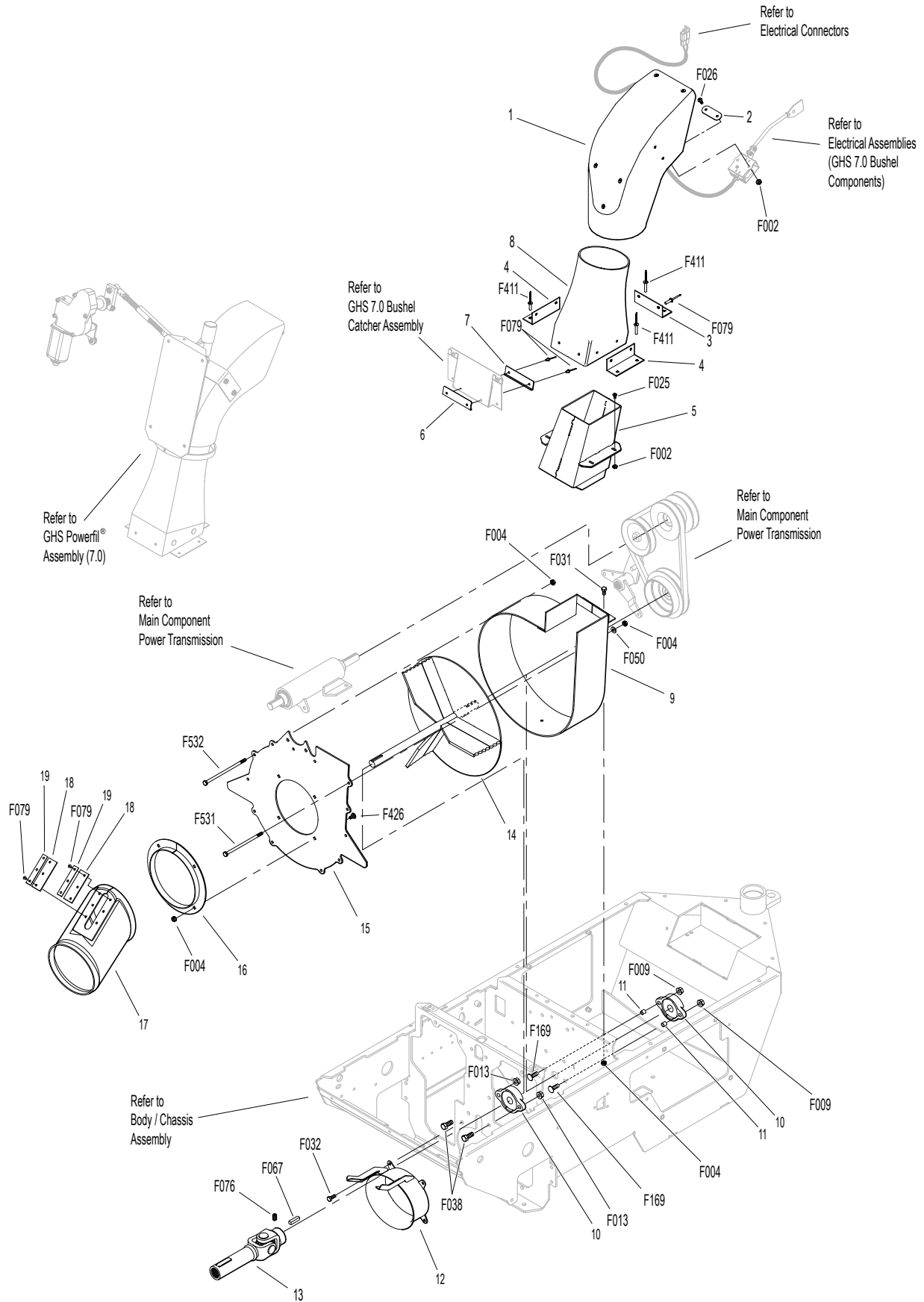

Beginning S/N 128442  
Effective Date 05-05-14  
Use only genuine **Walker**® replacement parts.

# GHS POWERFIL® ASSEMBLY (7.0)

ITEM NO.	PART NO.	DESCRIPTION	NO. REQ'D	ITEM NO.	PART NO.	DESCRIPTION	NO. REQ'D
<b>7.0 GHS Powerfil® Assembly</b>				<b>Fasteners</b>			
1	5552	Ball Joint (1/4-28)	2	F002		10-24 Keps Nut	10
2	5553-3	Bushing, Powerfil® Actuator	4	F003		1/4-28 Hex Nut	3
3	5553-1	Compression Spring (1/2 x 2)	2	F026		10-24 x 1/2 PPHMS	1
4	5558-2	Powerfil® Actuator Rod	1	F037		10-24 x 5/8 PTH Screw	2
	5549	Actuator Rod Assembly (Includes Items # 1-5 & F003)	*	F054		AN960616 Washer	1
5	5558-1	Powerfil® Push Rod	1	F085		3/16 Rivet Backup Washer	1
6	5551-3	Bearing Cap, Powerfil®	1	F101		10-24 x 1-1/4 SHC Screw	1
7	5551-1	Pivot Bearing (#S3PP)	2	F109		1/8 x 5/8 Roll Pin	1
8	5518-2	Pivot, Delivery Spout	1	F129		10-24 x 1/2 PTHMS	6
9	5517-2	Pivot Mount	1	F261		AN960616L Washer	1
10	5519-5	Actuator Motor (12V) (Includes Items # 11 & 12)	1	F287		1/4-28 Keps Nut	1
11	5519-2	Motor Mount Washer	*	* Service Part Only			
12	5519-3	Motor Mount Nut (5/8-24)	*				
13	5554	Actuator Arm	1				

# GHS POWERFIL® ASSEMBLY (7.0)

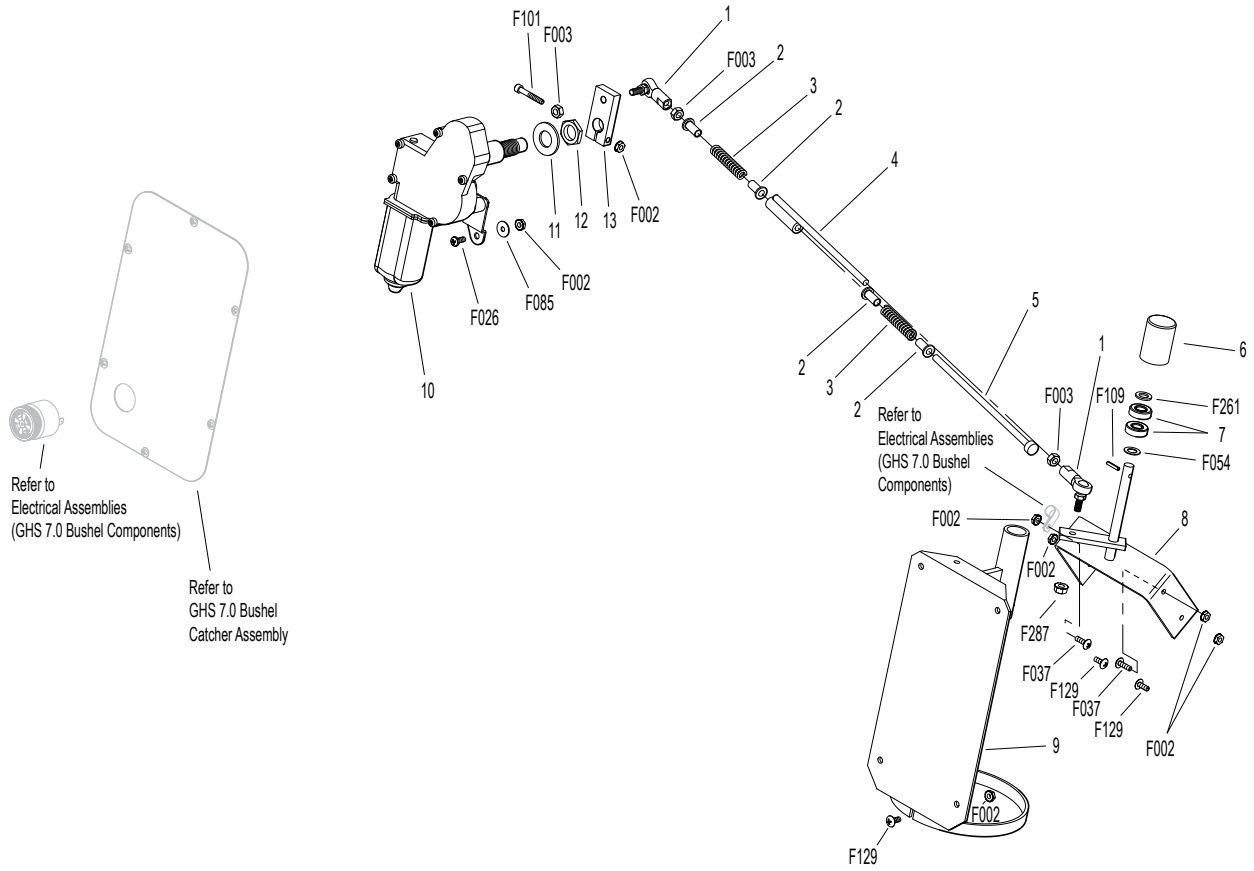

Beginning S/N 128442  
 Effective Date 05-05-14  
 Use only genuine **Walker®** replacement parts.

# GHS 7.0 BUSHEL CATCHER ASSEMBLY

ITEM NO.	PART NO.	DESCRIPTION	NO. REQ'D	ITEM NO.	PART NO.	DESCRIPTION	NO. REQ'D
<b>Upper Baffle Screen Assembly (Removable)</b>				37	7510-3	7.0 Bushel Catcher Box	1
					7502-6	7.0 Catcher W/Powerfil® (Includes Door)	*
1	7512-6	Removable Screen (3/16 Hole) (Includes Items # 2, F025 & F190)	1**	38	7607-8	Powerfil® Cover Plate	1
2	7506	Knob / Threaded Insert (10-24)	2	39	7608-2	Hinge Plate, RH	1
3	7509-2	Channel Top	2	40	8155-4	7.0 Gas Spring Cover, RH	1
4	8606-2	Channel Bottom	2	41	7607-12	Catcher Door Arm, RH	1
5	6856-1	Edge Molding (21-3/4")	1	42	7584-3	Reinforcing Strap	1
6	6507	Screen Seal (24")	1	43	5801-3	Decal Plate, Round (Set of 2)	1
7	7505	Mustache Spring	2	<b>5598-2 Optional Dump Bag (Not Shown)</b>			
8	7509-6	C-Channel With Spring (Includes Items # 7 & F340)	1	May be ordered as an option. Contact your Walker dealer.			
<b>7.0 Exhaust Deflector Door Assembly</b>				<b>Fasteners</b>			
9	7607-3	Upper Door Seal	1	F002	10-24 Keps Nut		23
10	7510-4	7.0 Catcher Box Door (Includes Frame) (Includes Items # 9, 11, 12, 14, F079, F085, F330 & F411)	1	F004	1/4-20 Keps Nut		27
11	5583	Handle	1	F009	5/16-18 Whiz Locknut		2
12	7607-6	Lower Door Stiffener (7.0)	1	F020	5/16-18 ESNA Nut		2
13	8607-8	Door Guide	1	F025	10-24 x 3/8 PPHMS		6
14	7607-5	Upper Door Stiffener	1	F027	10-24 x 5/8 PPHMS		8
<b>GHS 7.0 Bushel Catcher Assembly</b>				F029	1/4-20 x 1/2 Hex Bolt		2
15	7503-7	Center Strap (7.0)	1	F049	5/16 SAE Washer		4
16	7503-6	Upper Frame Doubler (7.0)	2	F050	1/4 SAE Washer		6
17	7503-5	Lower Frame Doubler (7.0)	2	F079	A/A66D Aluminum Pop Rivet		14
18	7503-4	Outside Box Strap (7.0)	2	F085	3/16 Rivet Backup Washer		8
19	8608-11	Catcher Door Finger	1	F094	8-32 x 1/2 PTHMS		6
20	8608-4	Center Frame Doubler	1	F129	10-24 x 1/2 PTHMS		14
21	7503-11	Catcher Mount	1	F178	1/4 x 1 Fender Washer		4
22	7620-3	Pivot Bushing (1/2 x 9/16)	4	F190	#10 Internal Star Lock Washer		2
23	7607-7	Bushing	2	F195	1/4-20 x 3/4 PPHMS, SS		4
24	7608-1	Hinge Plate, LH	1	F196	1/4-20 x 1 PPHMS, SS		4
25	7607-13	Catcher Door Arm, LH	1	F230	1/4-20 x 1-1/4 PPHMS, SS		4
26	8155-5	7.0 Gas Spring Cover, LH	1	F242	1/4-20 x 7/8 PPHMS, SS		6
27	5147	Spring Clip	4	F275	5/16-18 x 2 Hex Bolt		2
28	5155-5	Gas Spring	2	F330	3/16D x 21/32L Rivet, SS		4
29	5155-13	3/4 Ball Stud	2	F340	Rivet, Aluminum		4
30	5523-6	Gas Spring Plate	2	F351	Aluminum Pop Rivet		6
31	5155-12	5/16 Ball Stud	2	F360	1/4-20 x 3/8 Hex Bolt		4
32	5155-15	Box Support, Gas Spring	2	F390	1/4-20 x 7/8 Carriage Bolt		4
33	7532-1	Handle, Catcher Lift	2	F411	3/16 Bulbex Rivet		21
34	7511-6	Chute Cover	1	F477	1/4-20 x 5/8 Carriage Bolt		4
35	5976	Grommet (3/8 x 11/16)	1	F503	1/4-20 x 1-1/2 PPHMS, SS		1
36	7557-1	7.0. Wire Harness Channel	1	F524	3/16 x 3/8 Aluminum Rivet, Black		6
				* Service Part Only			
				** This screen can be replaced by P/N 7512-7 Removable Screen (3/4" holes) for improved air flow performance in wet conditions.			

# GHS 7.0 BUSHEL CATCHER ASSEMBLY

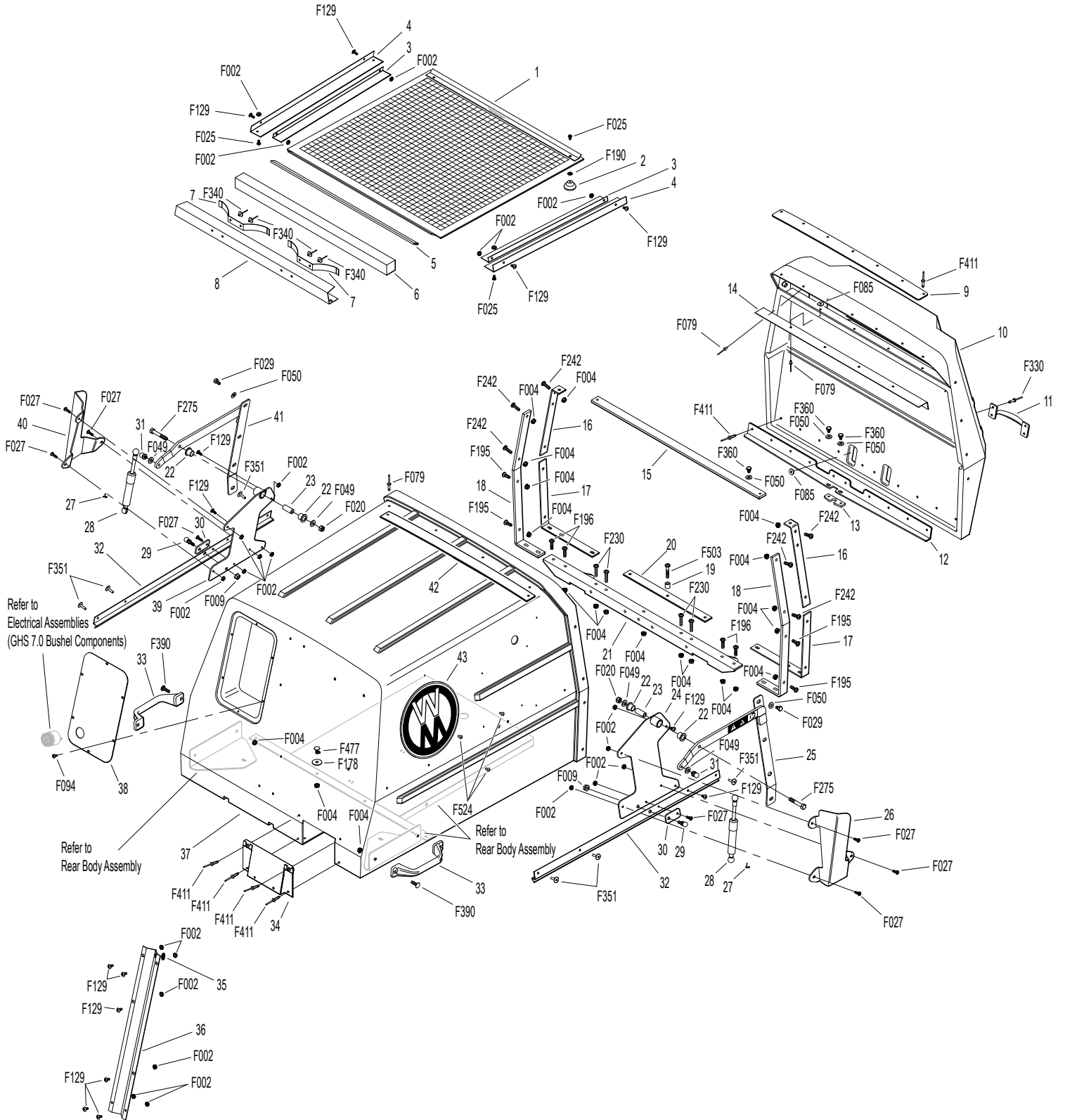

Beginning S/N 128442  
Effective Date 05-05-14  
Use only genuine Walker® replacement parts.

# ELECTRICAL ASSEMBLY

ITEM NO.	PART NO.	DESCRIPTION	NO. REQ'D	ITEM NO.	PART NO.	DESCRIPTION	NO. REQ'D
<b>Electrical Assembly</b>				<b>Fasteners</b>			
1	5942-11	Delta Hex Nut	1	F002		10-24 Keps Nut	4
2	5942-9	Safety Switch (NO), Delta Threaded	1	F004		1/4-20 Keps Nut	5
3	7834-3	Wire Saddle (3 Wires)	3	F019		1/4-20 ESNA Wing Nut	2
4	5832	Cable Clamp (1/2)	1	F025		10-24 x 3/8 PPHMS	1
5	5975-1	Cable Tie (18# x 3-3/4")	3	F026		10-24 x 1/2 PPHMS	3
6	5943-5	Wire Harness Assembly	1	F029		1/4-20 x 1/2 Hex Bolt	3
7	5942-10	Safety Switch (NC), Delta Side Mount	1	F031		1/4-20 x 5/8 Hex Bolt	2
8	5942-8	Safety Switch (NO), Delta Side Mount	1	F050		1/4 SAE Washer	4
9	4024-13	Safety Switch Plate	1	F112		5/8 x 1-1/4 x .03 Washer	3
10	6942	Relay Switch (30/40 Amp) NC (Includes Items # 11 & 12)	3	F146		1/4-20 Jam Nut	1
11	6941-6	Relay Switch (30/40 Amp)	*	F211		1/4-20 x 7/8 Hex Bolt	1
12	6941-7	Relay Mount	*	F349		Washer .835 ID 1.122 OD, SS	1
13	8990-1	Hourmeter (Global)	1	F505		6-32 x 7/8 Hex Trim MS, SS	4
14	8960-15	Ignition Switch (with Keys) (Includes Items # 15, 16 & F349)	1	F506		6-32 Nylock Nut	4
15	7854	Plastic Tip / Red	1	* Service Part Only			
16	8960-3	Key Set W/Umbrella	1	<b>NOTE:</b> Refer to <b>ELECTRICAL CONNECTORS</b> , Page 26, for identification of all Electrical Wiring Service Parts.			
17	7941-3	Boot, Circuit Breaker	1	<b>NOTE:</b> Decals for this assembly are not shown here. Refer to <b>TRACTOR DECALS</b> , Page 2, for Decal listing and placement information.			
18	7941-6	Circuit Breaker (15 Amp)	1				
<b>Battery Assembly</b>							
19	6923	Battery Cable (-)	1				
20	5932	Battery Terminal Insul., Black (-)	1				
21	5933	Battery Terminal Insul., Red (+)	1				
22	NS	Battery (12V/300.CA/Wet)	1				
23	5844-3	Battery Protector Plate	1				
24	5839	Hook Bolt	2				
25	4940-6	Battery Cable (33")	1				
26	6832	Cable Clamp (9/16 x 1/4)	1				



# ELECTRICAL ASSEMBLY

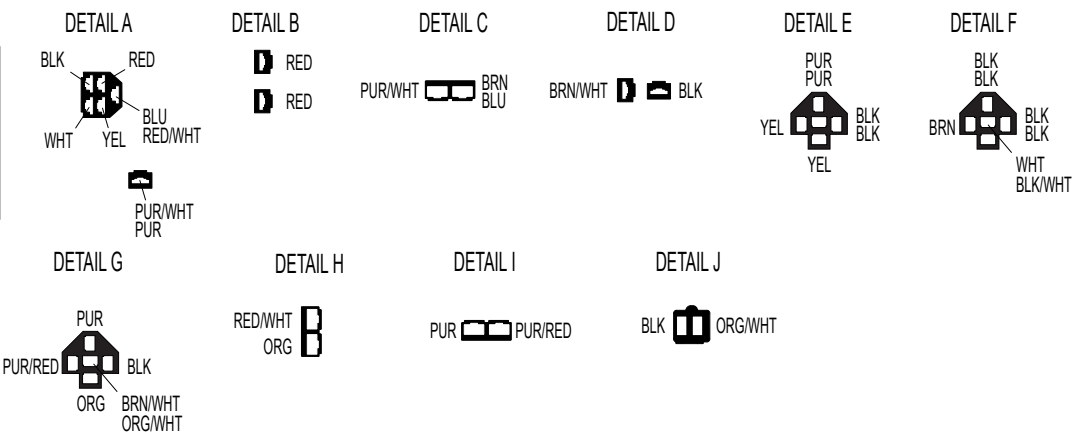
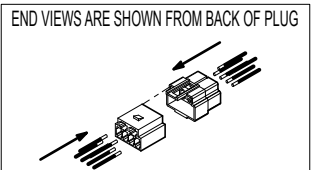
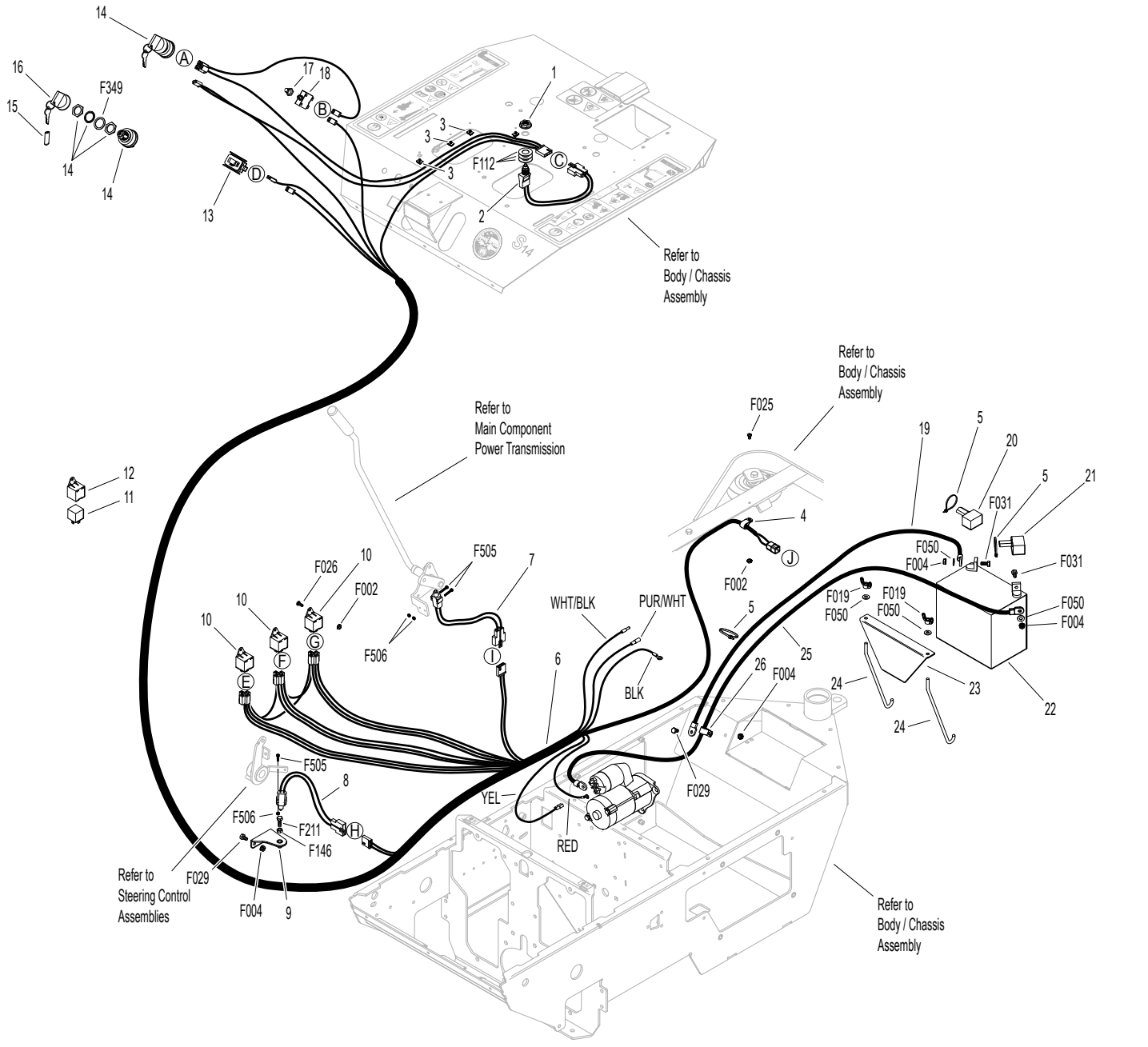

Beginning S/N 128442  
 Effective Date 05-05-14  
 Use only genuine **Walker**® replacement parts.

# ELECTRICAL ASSEMBLIES (GHS 7.0 BUSHEL COMPONENTS)

ITEM NO.	PART NO.	DESCRIPTION	NO. REQ'D	ITEM NO.	PART NO.	DESCRIPTION	NO. REQ'D
<b>Horn &amp; Harness Channel Assemblies</b>				<b>Fasteners</b>			
1	5536-2	Horn, Full Signal	*	F002		10-24 Keps Nut	4
2	5519-4	Adapter Harness	1	F025		10-24 x 3/8 PPHMS	1
3	5976-2	Grommet (3/16 x 3/4)	1	F037		10-24 x 5/8 PTH Screw	1
4	5975-1	Cable Tie (18# x 3-3/4")	1	F129		10-24 x 1/2 PTHMS	2
<b>Harness &amp; Grass-Pak® Switch Assemblies</b>				F508		4-40 Keps Nut, SS	2
5	8950	9.5 / 10.0 Wire Harness	1	F509		4-40 x 1/2 Hex Head, SS	2
6	5976	Grommet (3/8 x 11/16)	1	* Service Part Only			
7	5833	Cable Clamp (1/4)	2	<b>NOTE:</b> Refer to <b>ELECTRICAL CONNECTORS</b> , Page 26 for identification of all Electrical Wiring Service Parts.			
8	5594-6	Aluminum Shaft & Vane Assembly	1				
9	5592-14	Grass-Pak® Switch Assembly	1				

# ELECTRICAL ASSEMBLIES (GHS 7.0 BUSHEL COMPONENTS)

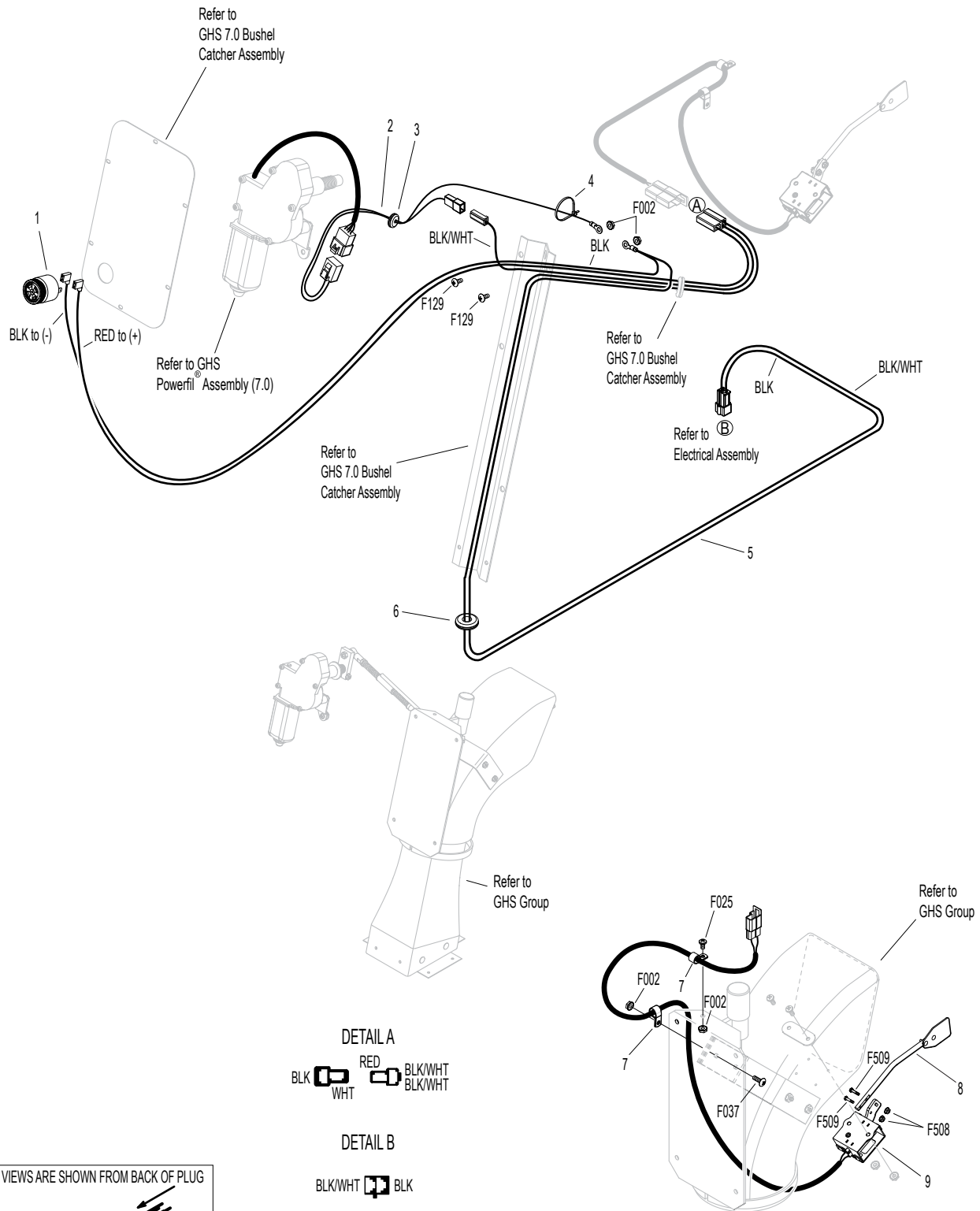

Beginning S/N 128442  
 Effective Date 05-05-14  
 Use only genuine **Walker**® replacement parts.

# ELECTRICAL CONNECTORS

ITEM NO.	PART NO.	DESCRIPTION	NO. REQ'D	ITEM NO.	PART NO.	DESCRIPTION	NO. REQ'D
<b>Electrical Wiring Service Parts</b>				29	7942-1	2-Way Locking Connector, Female	*
1	5996-1	16-14 GA Butt Connector	*	30	7942-2	2-Way Connector, Male	*
2	5996-11	12-10 GA Butt Connector	*	31	7942-3	2-Way Connector, Female	*
3	7942-14	16-14 GA Shrink Connector	*	32	7942-10	2-Way Locking Connector, Male	*
4	7942-13	12-10 GA Shrink Connector	*	33	5940-8	3-Way Connector, Male	*
5	5995-1	Wire Terminal Adapter	*	34	7942-9	3-Way Connector, Male	*
6	5996-4	16-14 GA Bullet Conn., Male	*	35	8944	3-Way Locking Connector, Male	*
7	5996-5	16-14 GA Bullet Conn., Female	*	36	8944-1	3-Way Locking Connector, Female	*
8	5940-4	16-14 GA Spg. Loaded Term., Female	*	37	7942-11	4-Way Connector, Male	*
9	5940-7	Wire Clip, Female	*	38	7942-12	4-Way Connector, Female	*
10	5996	1/4 x 16-14 GA QKS Term., Female	*	39	7942-5	5-Way Connector, Male	*
11	5996-2	3/16 x 22-18 GA QKS Term., Female	*	40	5940-2	5-Way Connector, Male	*
12	7996	16-14 GA QKS Term., Female	*	41	8942-1	5-Way Connector, Female	*
13	5940-5	16-14 GA Spg. Loaded Term., Male	*	42	7942-6	6-Way Connector, Male	*
14	5996-0	1/4 x 22-18 GA QKS Term., Male	*	43	7942-7	6-Way Connector, Male	*
15	5996-18	16-14 GA Ring Term. (#8) Nylon Insulated	*	44	7942-8	8-Way Connector, Male	*
16	7996-1	1/4 x 16-14 GA QKS Term., Male	*	45	8942-2	8-Way Connector, Female	*
17	5996-8	6 GA Ring Lug (5/16)	*	46	8942-3	5-Way Connector, Male	*
18	5996-9	22-18 GA Ring Term., #10	*	47	5940-9	3-Way Connector (M)	*
19	5996-10	16-14 GA Ring Term. (5/16)	*	48	7942-15	6-Way Connector (Female)	*
20	5996-12	12-10 GA Ring Term. (5/16)	*	49	7940-3	Packard Plug (Male)	*
21	5996-13	16-14 GA Ring Term., # 10	*	50	7940-4	Packard Plug (Female)	*
22	5996-15	12-10 GA Ring Term. (1/2)	*	* Service Part Only			
23	5996-16	6 GA Ring Terminal (1/4)	*	<b>NOTE:</b> Not all Electrical Connectors are used with all assemblies.			
24	5996-17	16-14 GA Ring Term. (1/4)	*	<b>NOTE:</b> Refer to <b>ELECTRICAL ASSEMBLY</b> , Page 22, for locations of Wiring Harness, Electrical Components and of all Electrical Wiring Service Parts.			
25	5996-20	12-10 GA Ring Term. (1/4)	*				
26	5996-21	12-10 GA Ring Term., #10	*				
27	7942-4	Single Connector, Male	*				
28	8942	2-Way Connector, Male	*				

# ELECTRICAL CONNECTORS

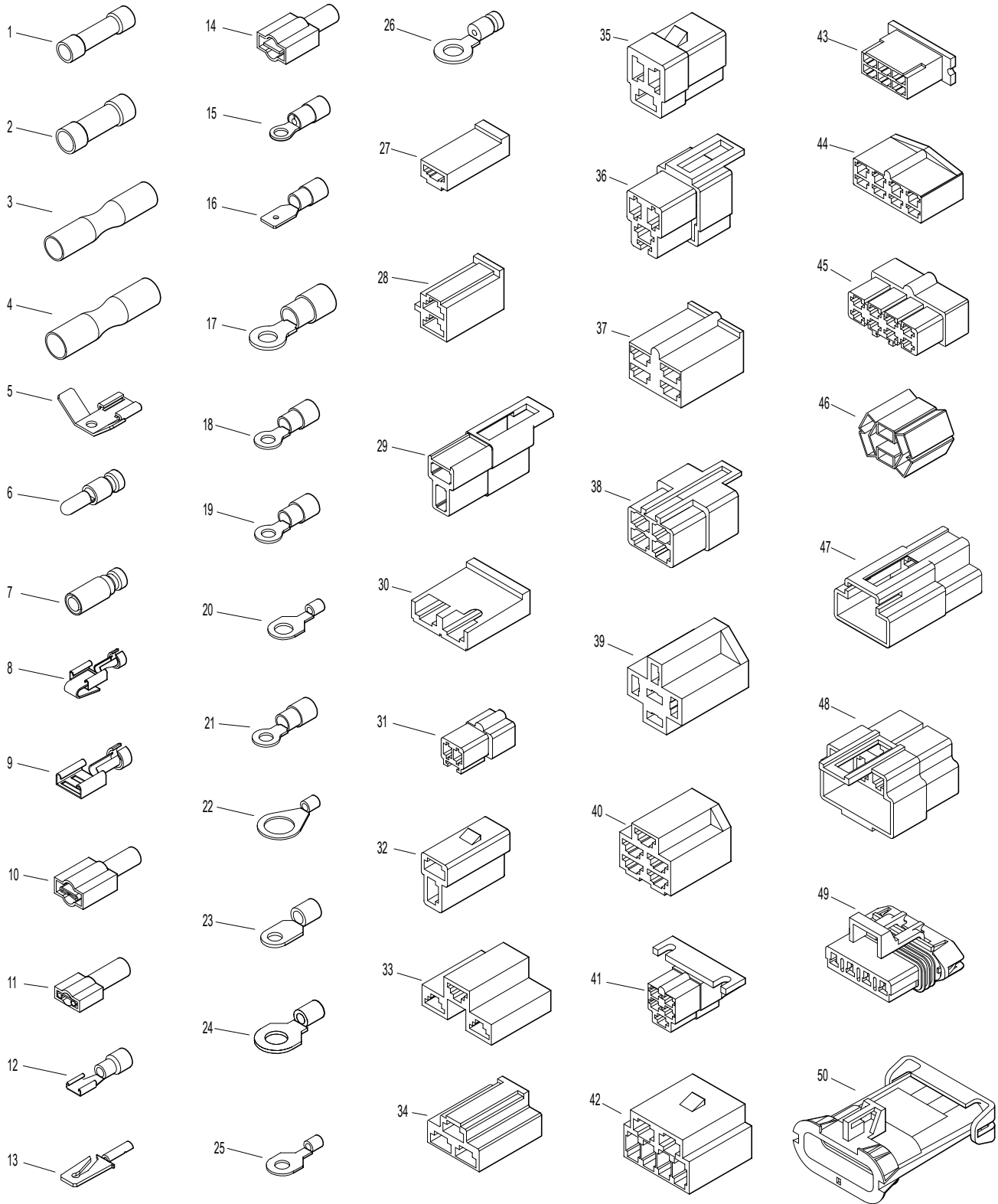

Beginning S/N 128442  
Effective Date 05-05-14  
Use only genuine Walker® replacement parts.

# LUBRICATION POINTS

ITEM NO.	LOCATION	LUBRICATION TYPE	NO. PLACES	ITEM NO.	LOCATION	LUBRICATION TYPE	NO. PLACES
<b>Lubrication Points</b>				12	Engine Dipstick / Oil Filler	Oil**	1
1	Steering Lever Pivot	Grease	2	13	Catcher Hinge Point	Oil	2
2	FSC Lever Pivot	Grease	1	14	Choke Control Cable Ends	Oil	2
3	Deck-to-PTO Coupling (Grease Spline Slide Area)	Grease	1	15	Throttle Control Cable Ends	Oil	2
4	Transaxle Oil Reservoir	Oil/20W-50	2	16	Engine Idler Pivot	Grease	1
5	Universal Joint Tube Assembly	Grease*	1	17	Parking Brake Lever	Grease	1
6	Deck Support Arm Pivot	Grease	2	18	Choke Control Pivot	Oil	1
7	Hydro Idler Pivot	Grease	1	19	Throttle Control Pivot	Oil	1
8	PTO Clutch Lever Pivot	Grease	1	* Grease every eight (8) hours.			
9	Body Latch Pivot	Oil	1	** Refer to <b>Engine Oil</b> in Operator's Manual.			
10	Clutch Actuator Push Rod (Grease Slide Area)	Grease	1	<b>NOTE:</b> See Model S14 <b>Operator's Manual</b> (P/N 5000-28) for proper lubrication intervals.			
11	PTO Belt Tightener Pivot	Grease	1				

# LUBRICATION POINTS

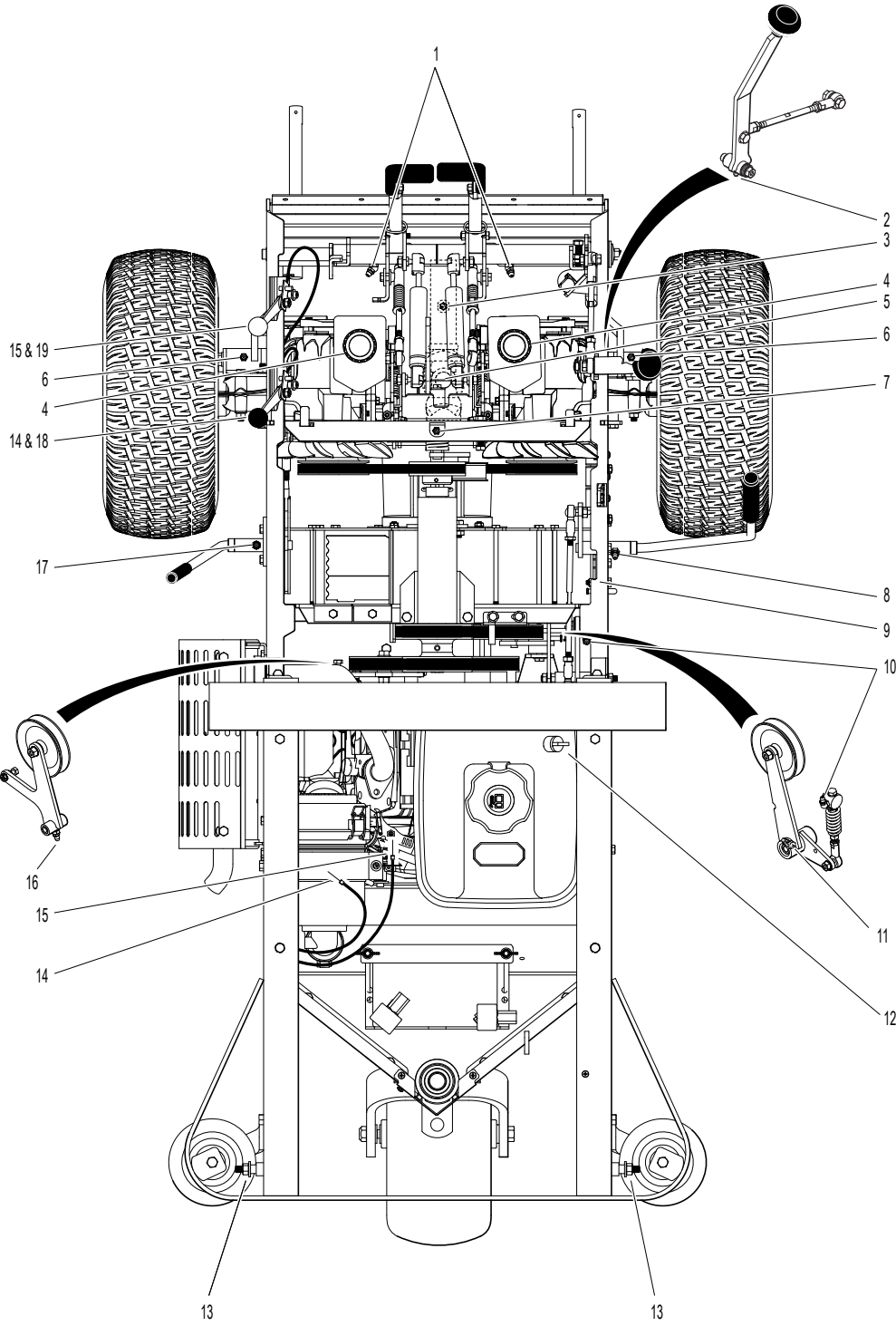

Beginning S/N 128442  
Effective Date 05-05-14  
Use only genuine **Walker**® replacement parts.

# WIRING SCHEMATIC

## WALKER MODEL S14 Beginning S/N 2014-128442

IGNITION SWITCH CIRCUITS	
OFF	G + M
START	B + A / S1 + S2
RUN	B + A

S1 = START CIRCUIT  
S2 = START/ACCESSORY CIRCUIT  
M = MAGNETO GROUND CIRCUIT  
B = BATTERY CIRCUIT  
A = ACCESSORY CIRCUIT  
G = GROUND CIRCUIT

RELAY - A START RELAY	
OFF	30 + 87A
START	30 + 87
RUN	30 + 87

RELAY - B IGNITION RELAY	
OFF	30 + 87A
START	30 + 87
RUN	30 + 87

RELAY - C PTO INTERLOCK RELAY	
OFF	30 + 87A
START	30 + 87
RUN	30 + 87
PTO ON	30 + 87

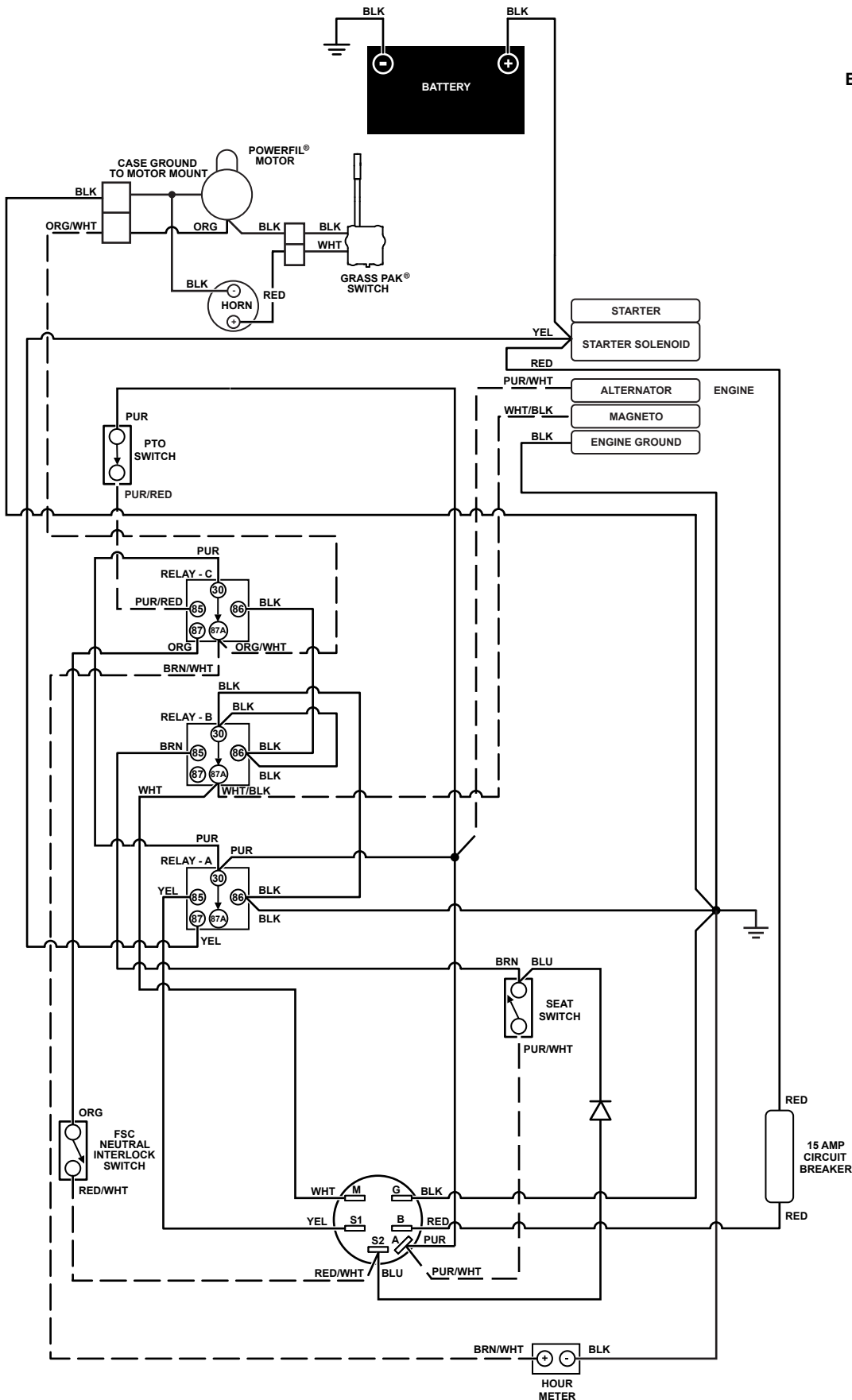

Beginning S/N 128442

Effective Date 05-05-14

Use only genuine Walker® replacement parts.



# OPERATOR'S NOTES

---

# OPERATOR'S NOTES

---

# LIMITED WARRANTY FOR WALKER MODEL S14 RIDER MOWER

## 1. WHAT THIS WARRANTY COVERS, AND FOR HOW LONG:

Walker Manufacturing company will, at its option, repair or replace, without charge, any part covered by this warranty which is found to be defective in material and/or workmanship within one (1) year\* after date of sale to the original retail purchaser unless the product is used for rental purposes, in which case this warranty is limited to ninety (90) days. At Walker's request, customer will make the defective part available for inspection by Walker and/or return the defective part to Walker, transportation charges prepaid. All parts and components of the Walker Mower are covered by this warranty **except** the following components which are warranted separately by their respective manufacturers:

Subaru Engine  
Hydro-Gear Transaxles  
Battery  
Tires

The available warranties covering these items are furnished with each mower. Walker does not assume any warranty obligation, liability or modification for these items, which are covered exclusively by the stated warranty of the respective manufacturers noted above.

\* A two (2) year or 2000 hour (whichever comes first) warranty is offered for Hydro-Gear ZT3100 hydrostatic transmissions; covers full cost of replacement up to 1000 hours of use, and after 1000 hours warranty coverage is prorated against 2000 hours.

## 2. WHAT THIS WARRANTY DOES NOT COVER:

- A. This warranty does not cover defects caused by depreciation or damage caused by normal wear, accidents, improper maintenance, improper use or abuse of the product, alterations, or failure to follow the instructions contained in the Operator's Manual for operation and maintenance.
- B. The customer shall pay any charges for making service calls and/or for transporting the mower to and from the place where the inspection and/or warranty work is performed.

## 3. HOW TO OBTAIN SERVICE UNDER THIS WARRANTY:

Warranty service can be arranged by contacting the dealer where you purchased the mower or by contacting Walker Manufacturing Company, 5925 East Harmony Road, Ft. Collins, CO 80528. Proof of the date of purchase may be required to verify warranty coverage.

## 4. WARRANTY LIMITATION:

- A. **THERE IS NO OTHER EXPRESS WARRANTY. ANY WARRANTY THAT MAY BE IMPLIED FROM THIS PURCHASE INCLUDING MERCHANTABILITY AND FITNESS FOR A PARTICULAR PURPOSE IS HEREBY LIMITED TO THE DURATION OF THIS WARRANTY AND TO THE EXTENT PERMITTED BY LAW ANY AND ALL IMPLIED WARRANTIES ARE EXCLUDED.** Some states do not allow limitations on how long an implied warranty lasts, so the above limitations may not apply to you.
- B. **WALKER WILL NOT BE LIABLE FOR ANY INCIDENTAL, CONSEQUENTIAL, OR SPECIAL DAMAGES AND/OR EXPENSES IN CONNECTION WITH THE PURCHASE OR USE OF THE MOWER.** Some states do not allow the exclusion or limitation of incidental or consequential damages, so the above limitation(s) or exclusion(s) may not apply to you.
- C. Only the warranty expressed in this limited warranty shall apply and no dealer, distributor, or individual is authorized to amend, modify, or extend this warranty in any way. Accordingly, additional statements such as dealer advertising or presentations, whether oral or written, do not constitute warranties by Walker, and should not be relied upon.
- D. This warranty gives you specific legal rights, and you may also have other rights which vary from state to state.

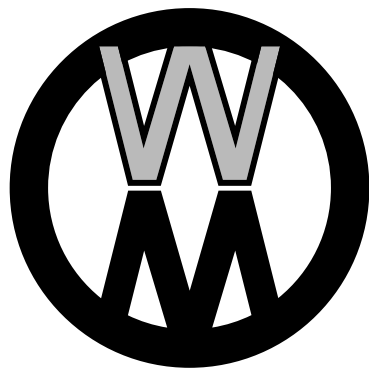

**WALKER**

**WALKER MFG. CO. • 5925 E. HARMONY ROAD, FORT COLLINS, CO 80528 • (970) 221-5614**  
**FORM NO. 050514      PRINTED IN USA      [www.walkermowers.com](http://www.walkermowers.com)      ©2014 WALKER MFG. CO**