

# WALKER MOWERS

## ILLUSTRATED PARTS MANUAL

Model MS



Beginning S/N: 117172  
Effective Date: 05-04-12  
P/N 5000-22

# KEY TO ABBREVIATIONS USED IN THIS MANUAL

<i>Abbreviation</i>	<i>What it Represents</i>
° (Dimension)	Degrees (Angle)
" (Dimension)	inches
(-)	Negative (Polarity)
(+)	Positive (Polarity)
AT	All-Terrain
CCW	Counter-clockwise
Conn	Connector
CW	Clockwise
D	Diameter
DGHS	Deck, Grass Handling System (number refers to size in inches)
DML	Deck, Mulching (number refers to size in inches)
DSD	Deck, Side Discharge (number refers to size in inches)
DU	Garlock (Bearing)
ESNA (Fastener)	Nylon Insert Locknut
FSC	Forward Speed Control
GA	Gauge
gal	gallon
GHS	Grass Handling System
GR (Fastener)	Grade
HP	Horse Power
HT	Heat-Treated
ID	Identification or Inside Diameter
L	Length
LH	Left Hand (orientated with operator on seat)
LP	Low Profile
mm (Dimension)	millimeters
MS (Fastener)	Machine Screw
NS (as part number)	Item is not sold by Walker Manufacturing
OD	Outside Diameter
oz	ounce
PFH (Fastener)	Phillips Flat Head
P/N	Part Number
PPH (Fastener)	Phillips Pan Head
PTH (Fastener)	Phillips Truss Head
PTO	Power Take-Off
QKS	Quick Slide
qt	quart
RH	Right Hand (orientated with operator on seat)
SAE (Fastener)	Society of Automotive Engineers
SBH (Fastener)	Socket Button Head (Bolt)
SD	Side Discharge
SFH (Fastener)	Slotted Flat Head
SHC (Fastener)	Socket Head Cap
SHL (Fastener)	Shoulder (Bolt)
SM (Fastener)	Sheet Metal (Screw)
S/N	Serial Number
Spg	Spring
SQH (Fastener)	Square Head
SS (Fastener)	Stainless Steel
ST (Fastener)	Self-Tapping (Screw)
Term	Terminal
V	Volts

**NOTE:** In some instances, combinations of abbreviations may be used (e.g. PPHMS - Phillips Pan Head Machine Screw).

# ILLUSTRATED PARTS LIST

<i>Section of Mower Covered</i>	<i>Page</i>	<i>Section of Mower Covered</i>	<i>Page</i>
<hr/>		<hr/>	
<b>Decals</b>		<b>Electrical Components</b>	
Tractor Decals .....	2	Electrical Assembly .....	24
<b>Body / Chassis Assemblies</b>		Electrical Assemblies (GHS 6.7 Bushel Components).....	26
Body / Chassis Assembly .....	4	Electrical Connectors.....	28
<b>Tractor Components</b>		<b>Options and Kits</b>	
Main Component Power Transmission .....	6	Armrest Kit / Touch-Up Paint .....	30
Engine Group .....	8	Comfort Seat / Armrest Kit.....	32
Hydrostatic Ground Drive Assemblies.....	10	Light Kit .....	34
Parking Brake Assembly .....	12	No Catch Deflector Kit (6.7 Bushel).....	36
Steering Control Assemblies.....	14	Optional Tires & Tire Chain Sets .....	38
Throttle & Choke Control Assemblies.....	16	<b>Maintenance</b>	
GHS Group .....	18	Lubrication Points .....	40
GHS Powerfil® Assembly .....	20	Wiring Schematic .....	42
GHS 6.7 Bushel Catcher & Exhaust Deflector Assemblies .....	22	<b>Operator's Notes</b> .....	43
		<b>Warranty</b>	
		Limited Warranty .....	45

# TRACTOR DECALS

ITEM NO.	PART NO.	DESCRIPTION	LOCATION	NO. REQ'D GHS
<b>Walker Product Decals</b>				
1	5801	GHS	6.7 Bushel Catcher (one on each side)	2
2	5813-1	Powerfil®	6.7 Bushel Catcher, Front	1
3	5802-2	LH Fender	Body, LH near Seat	1
4	5856	Made in USA	Body	1
5	5803	Walker Manufacturing Logo	Body	1
6	5802-1	RH Fender	Body, RH near Seat	1
7	5806	Blade Clutch	Body, RH Side	1
<b>Danger Decals Warning Decals Caution Decals</b>				
8	5868	Danger, Pinch Point	6.7 Bushel Catcher Mounting Frame Assembly (one on each side)	2
9	5861	Danger, Raised Body	Body - Underside, Center	1
10	6810	Danger, Engine Exhaust	Engine	1
11	5805	Caution, Engine Exhaust	Body, LH Side	1
12	5804	Danger, Rotating Blower Blades	Body, Near Body Chute	1
13	5810-3	Decal, Hydro Warning	Bridge Assembly and LH Gear Axle Drive Assembly	2
<b>Maintenance Decals</b>				
14	5874	Push to Release	6.7 Bushel Catcher Safety Latch	1
15	5869	Removable Screen	6.7 Bushel Catcher Removable Screen	1
16	5815	Body Lift	Rear Bumper	1
17	5855	Important, Engine Cooling	Engine	1
18	5810-1	Axle Oil Level	Gear Axle Drive Assemblies (one on each)	2
19	NS	Sealed Reservoir	Hydrostatic Drives (one on each)	2
20	6875	PTO Alignment Arrow	Universal Joint Tube Assembly	1
21	7809	Parking Brake	Body, RH below seat (Gear Drive Models only)	1
<b>Option Decals (applied only to units with corresponding Options installed)</b>				
22	5877	Lights, On-Off	Body	1
	8500-8	No Catch Deflector	6.7 Bushel No Catch Deflector, LH Side (Refer to 6.7 Bushel No Catch Deflector Kit Listing)	1
	8500-9	No Catch Deflector, Off-On	Body, RH above fender (Refer to 6.7 Bushel No Catch Deflector Kit Listing)	1

**NOTE:** All parts requiring decals are shipped with decals applied.

# TRACTOR DECALS

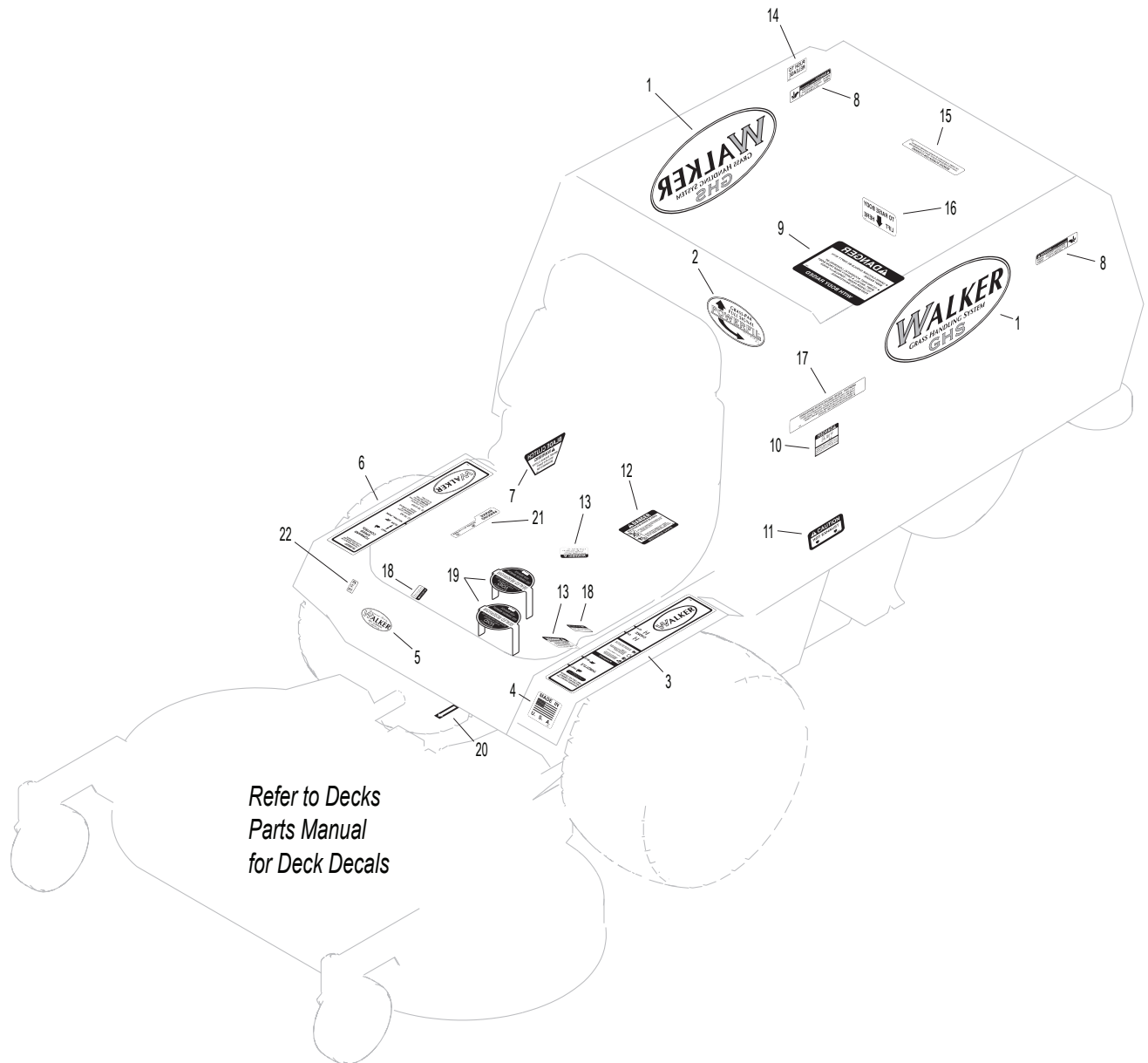

# BODY / CHASSIS ASSEMBLY

ITEM NO.	PART NO.	DESCRIPTION	NO. REQ'D	ITEM NO.	PART NO.	DESCRIPTION	NO. REQ'D
<b>Seat Assembly</b>				36	5035	Tail Wheel & Tire Assembly (13 x 6.50-6)	1
1	5103	Seat	1		5035-1	Tail Wheel Tire (13 x 6.50-6)	*
2	7203	Seat Spring Plate	1		5036	Tail Wheel & Hub (6 x 4.5)	*
3	7223-1	Compression Spring	2	37	5038-1	Axle Spacer Tube (6-5/8)	1
4	7846	Rubber Washer (3/8 x 1-1/4 x 1/8)	2	38	5033-6	Wheel & Tire (18 x 7.00-8)	2
5	5841-1	Retainer Washer	2		5030-6	Standard Tire (18 x 7.00-8)	*
6	7845	Rubber Bumper (1.375 x .63)	2		5031-2	Standard Wheel (8 x 5.5)	*
7	7440-5	Shock Mount (1-1/4 x 3/4)	2		5030-4	Tire Tube (18 x 8.50-8)	*
				39	5300-3	Chassis Frame	1
				40	5301-3	Safety Switch Mount	1
<b>Rear Bumper Assembly</b>				<b>Fasteners</b>			
8	5566	Tilt Stop Strap	1		F002	10-24 Keps Nut	2
9	5517-1	Bumper	1		F004	1/4-20 Keps Nut	4
10	7516-5	Catcher Pivot Bushing	2		F009	5/16-18 Whiz Locknut	11
11	5162	Roller Wheel (5" Rubber)	2		F012	3/8-16 Keps Nut	2
12	7517-2	Catcher Pivot Plate	2		F013	3/8-16 Whiz Locknut	2
13	6100-17	Bumper Riser Bar	2		F014	3/8-16 ESNA Nut	4
					F016	1/2-13 Self-Locking Nut	1
					F020	5/16-18 ESNA Nut	1
					F026	10-24 x 1/2 PPHMS	1
					F027	10-24 x 5/8 PPHMS	1
					F029	1/4-20 x 1/2 Hex Bolt	2
					F031	1/4-20 x 5/8 Hex Bolt	3
					F040	3/8-16 x 1-1/2 Hex Bolt	2
					F048	1/2 SAE Washer	2
					F051	3/8 SAE Washer	2
					F059	3/8 Wave Spring Washer	2
					F085	3/16 Rivet Backup Washer	1
					F087	#10 x 7/8 Fender Washer	2
					F093	5/16-18 x 1 Hex Bolt	5
					F151	3/8-16 x 7/8 Hex Bolt	2
					F157	1/2-20 x 1-1/4 Wheel Lug Bolt	8
					F206	#2 x 3/16 Drive Pin	2
					F227	3/8 x 1-1/4 x 1/8 Washer	2
					F241	.375 x .875 x .10 Washer	4
					F257	3/8 x 1-11/16 Shoulder Bolt	2
					F292	1/2-13 x 8-1/2 Hex Bolt, GR 2	1
					F341	Coil Roll Pin (7/64 x 9/16)	1
					F342	5/16 Conical Washer	2
					F413	5/16-24 x 5/16 Set Screw	2
<b>Body Assembly</b>							
14	5100-8	Welded Body	1				
15	5989-3	Dome Plug (5/16)	2				
16	5989-4	Dome Plug (3/8)	2				
17	7147	Spring Clip	2				
18	5145	Gas Spring Assembly (Includes Items # 17 & 19)	1				
19	7146	13mm Ball Stud	2				
20	5154	Spacer, Gas Spring	1				
21	5180	Edge Molding, Lever Opening	2				
22	5989-5	Dome Plug (7/16)	1				
23	NS	Body ID Plate	1				
<b>Tilt-Up Latch Assembly**</b>							
24	5847	Plastic Tip	1				
25	5744-20	Spring Arm, Tilt-Up Latch	1				
26	5744-10	Spring Pivot Bushing	1				
27	5744-15	Compression Spring (3/8 x 5/8)	1				
28	5744-13	Mount Angle, LH	1				
29	5744-12	Hook, Tilt-Up Latch	1				
30	5744-14	Mount Angle, RH	1				
<b>Chassis Assembly</b>							
31	5845	Rubber Bumper (1.50 x 1.25)	2				
32	5267-1	Retainer Collar (1") (Includes Item # F413)	1				
33	5270-1	Pivot Bearing	2				
34	5420-2	Tail Wheel Fork	1				
35	5037-1	Bearing, Tail Wheel	2				

\* Service Part Only

\*\* Complete Tilt-Up Latch Assembly Kit available by ordering kit # 5747.

Beginning S/N 117172

Effective Date 05-04-12

Use only genuine **Walker**® replacement parts.

# BODY / CHASSIS ASSEMBLY

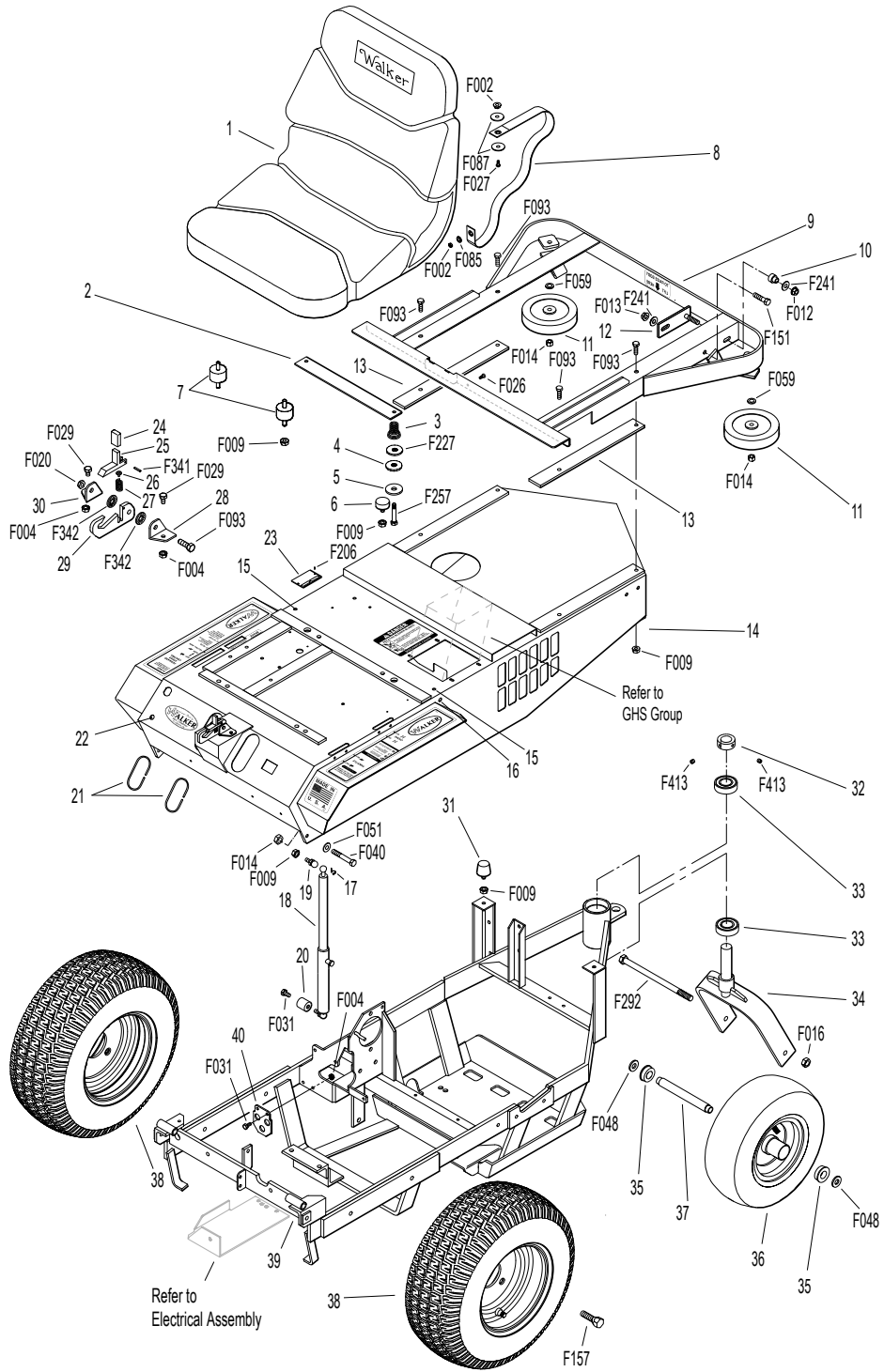

Beginning S/N 117172  
Effective Date 05-04-12  
Use only genuine **Walker**® replacement parts.

# MAIN COMPONENT POWER TRANSMISSION

ITEM NO.	PART NO.	DESCRIPTION	NO. REQ'D	ITEM NO.	PART NO.	DESCRIPTION	NO. REQ'D
<b>Clutch Control Assembly</b>				<b>PTO Drive Shaft Assembly</b>			
1	5860	Knob, PTO Clutch	1	27	5236-1	Transmission Drive Pulley (3-1/4/A) (Includes Items # F065 & F171)	1
2	5281-2	Clevis Pin (5/16 x 7/8)	1	28	5245	Idler Pulley (3")	2
3	5830	Grease Fitting	5	29	5232	Ground Drive Belt (#6847 or AX45)	1
4	5244	PTO Idler Pulley (3-1/2)	1	30	5275-15	Universal Joint Tube Assembly (Includes Item # F076)	1
5	5346-3	PTO Belt Tightener (Includes Item # 3)	1	31	5264	Pillowblock Bearing, Short Mount (Includes Item # 3)	1
6	5229	Extension Spring (1/2 x 2-1/4)	2	32	5274	PTO Drive Shaft	1
7	7226	Compression Spring (3/4 x 2-1/2)	1	33	5706-4	Seal Protector Plate	1
8	5406-2	Clutch Actuator	1	34	5830-4	Grease Fitting (90 Degree)	1
9	5410	Clutch Control Lever (Includes Item # 3)	1	35	5263	Pillowblock Bearing (Includes Item # 34)	1
<b>Blower Brake Assembly</b>				36	5050-1	Right Angle Gearbox (Includes Items # 33 & F124)	1
10	5346-5	Brake Actuator Mount	1	37	5480-2	Belt Guide, PTO Drive	1
11	5346-4	Brake Actuator Arm	1	<b>Fasteners</b>			
12	5355-3	Retainer Clip	1	F002	10-24 Keps Nut		1
13	5355-2	Brake Actuator Link	1	F004	1/4-20 Keps Nut		1
14	5360	Brake Mount	1	F005	1/4-20 ESNA Nut		1
15	5355-1	Brake Link	1	F012	3/8-16 Keps Nut		16
16	5358	Brake Bar	1	F032	1/4-20 x 3/4 Hex Bolt		3
17	7412	Clevis Pin (3/16 x 5/8)	2	F038	3/8-16 x 1 Hex Bolt		6
<b>Engine Belt Tightener Assembly</b>				F039	3/8-16 x 1-1/4 Hex Bolt		4
18	5240-2	Compound Pulley (4-1/4 / A/B) (Includes Items # F065 & F171)	1	F040	3/8-16 x 1-1/2 Hex Bolt		4
19	5230-2	Engine Belt (#6932 or BX30)	1	F049	5/16 SAE Washer		1
20	5247-2	V-Groove Idler Pulley (4")	1	F051	3/8 SAE Washer		4
21	5237-1	Engine Pulley (4-1/4 / B) (Includes Items # F066 & F171)	1	F054	AN960616 Washer		2
22	5495	Engine Belt Tightener Assembly (Includes Item # 3)	1	F065	3/16 x 3/4 Woodruff Key (#606)		2
23	5221	Extension Spring (3/4 x 4)	1	F066	1/4 x 1/4 x 3/4 Key		1
<b>Transmission Belt Tightener Assembly</b>				F067	3/16 x 3/16 x 1 Key		1
24	5290-2	Belt Tightener Arm (Includes Item # 3)	1	F076	3/8-16 x 5/8 SQH Set Screw		1
25	5227-1	Extension Spring (1/2 x 4)	1	F111	1/8 x 3/4 Cotter Pin		1
26	6237	Bolt & Spring Hook	1	F113	5/16-18 x 5/16 Set Screw		2
				F120	AN960416 Washer		1
				F124	10-32 x 3/8 Taptite MS		3
				F127	1/16 x 1/2 Cotter Pin		2
				F133	1/4 Wave Spring Washer		4
				F136	AN960C416L Washer		4
				F138	3/8-16 x 1/2 x 1-1/2 SHL Bolt		1
				F146	1/4-20 Jam Nut		1
				F153	3/16 x 3/16 x 1-1/4 Key		1
				F171	5/16-18 x 3/8 Set Screw		4
				F179	1/4-20 x 1 Hex Bolt		1
				F291	1/4 x 1/4 Shoulder Bolt		1
				F350	1/4-20 LP Nylock		1

Beginning S/N 117172

Effective Date 05-04-12

Use only genuine **Walker**® replacement parts.



# MAIN COMPONENT POWER TRANSMISSION

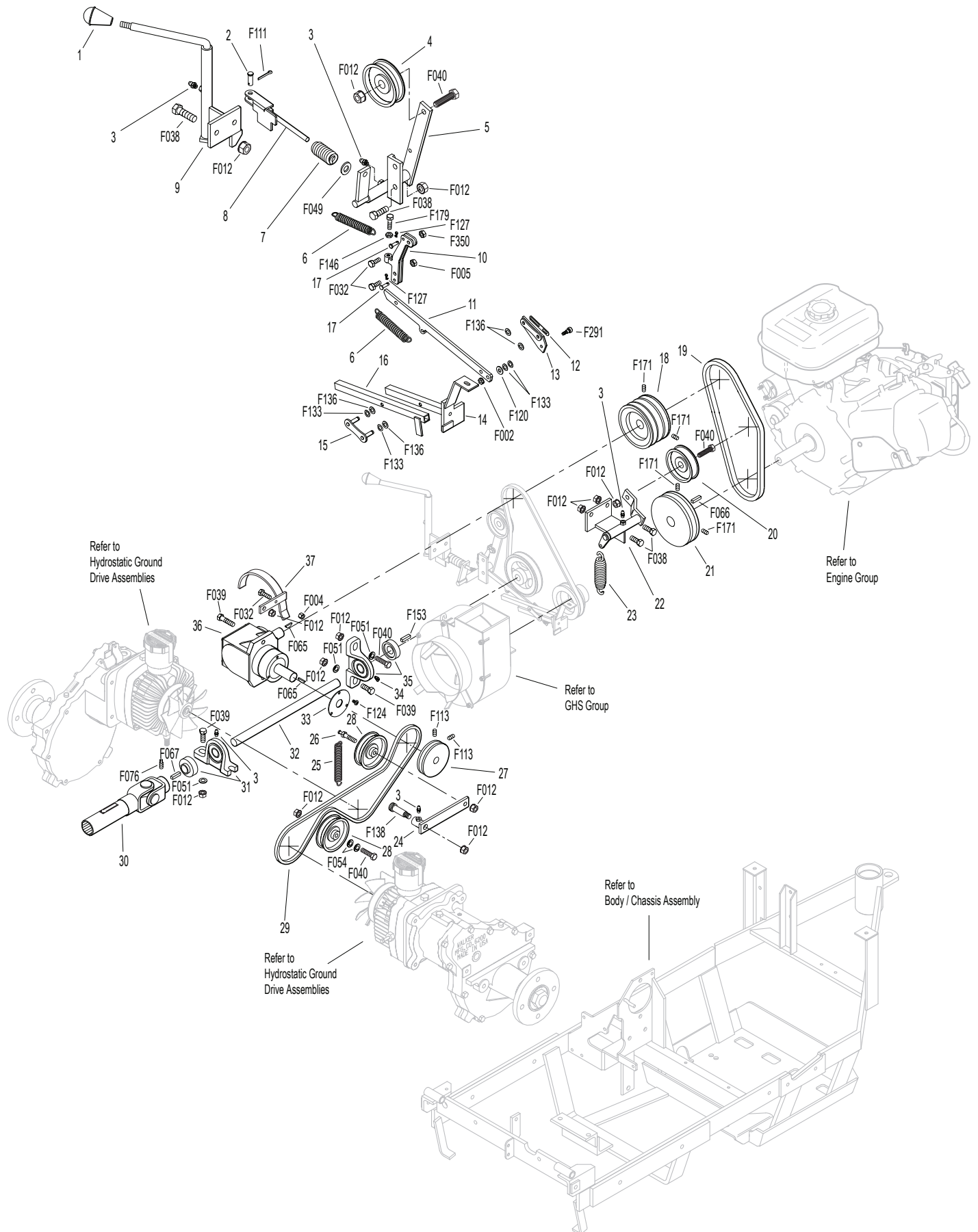

Beginning S/N 117172  
 Effective Date 05-04-12  
 Use only genuine Walker® replacement parts.

# ENGINE GROUP

ITEM NO.	PART NO.	DESCRIPTION	NO. REQ'D	ITEM NO.	PART NO.	DESCRIPTION	NO. REQ'D
<b>Air Cleaner &amp; Engine Assembly</b>				<b>Fasteners</b>			
1	6090-11	Air Cleaner Assembly (Includes Items # 1 & 4-7)	1	F012		3/8-16 Keps Nut	2
2	5090-2	Vacuator™ Valve	1	F038		3/8-16 x 1 Hex Bolt	2
3	5088-1	Air Cleaner Band	1	F039		3/8-16 x 1-1/4 Hex Bolt	2
4	5090-3	Safety Filter Insert	1	F050		1/4 SAE Washer	2
5	5090-1	Air Cleaner Cartridge	1	F051		3/8 SAE Washer	2
6	5091-9	Street Elbow 90° (1/8 x 1/8)	1	F061		1/4 Star Lock Washer	2
7	5091-0	1/8 Pipe Thread Male W/Barb	1	F063		3/8 Internal Star Lock Washer	2
8	M258	Vacuum Hose (7/64 x 10")	1*	F091		5/16-18 x 5/8 Hex Bolt	2
9	5091-6	Air Flow Indicator W/Bracket	1	F179		1/4-20 x 1 Hex Bolt	2
10	7840	Hose Clamp (1-5/16 to 2-1/4)	2	F184		1/4-20 x 1/2 Hex Bolt, SS	4
11	5087-2	Air Intake Hose	1	F185		1/4 Internal Star Lock Washer, SS	4
12	5011-11	Intake Tube	1	F217		7/16-14 Hex Nut	4
13	5011-12	Intake Pipe / Gasket	1	F218		7/16 Split Lock Washer	4
14	5879-3	Hose Clamp (1/2)	3	F281		7/16-14 x 1-3/4 Hex Bolt	4
15	M247	Fuel Line (5/16 x 1")	1*	F482		8-32 Nylock Nut	2
16	5011-9	90 Degree Elbow 5/16"	1	F483		8-32 x 3/4 PPHMS	2
17	M247	Fuel Line (5/16 x 6")	1*	<b>* Required hose specifications:</b> M247 – 5/16" ID low permeation (<15g/m <sup>2</sup> /day) fuel hose (Parker 38905 or equivalent) M258 - 7/64" ID automotive vacuum hose			
18	NS	14 HP Engine (Subaru) (Includes Items # 19 & 20)	1				
19	NS	O-Ring	1				
20	NS	Engine Plug	1				
21	5014-4	Engine Brace, RH	1				
22	5014-3	Engine Brace, LH	1				
<b>Exhaust Assembly</b>							
23	NS	Nut	2				
24	NS	Gasket, Muffler	1				
25	5013-10	Muffler	1				
26	5013-3	Muffler Heat Shield	1				
27	4024-8	T-Bolt Latch Clamp	1				
28	5013-7	Exhaust Pipe	1				

# ENGINE GROUP

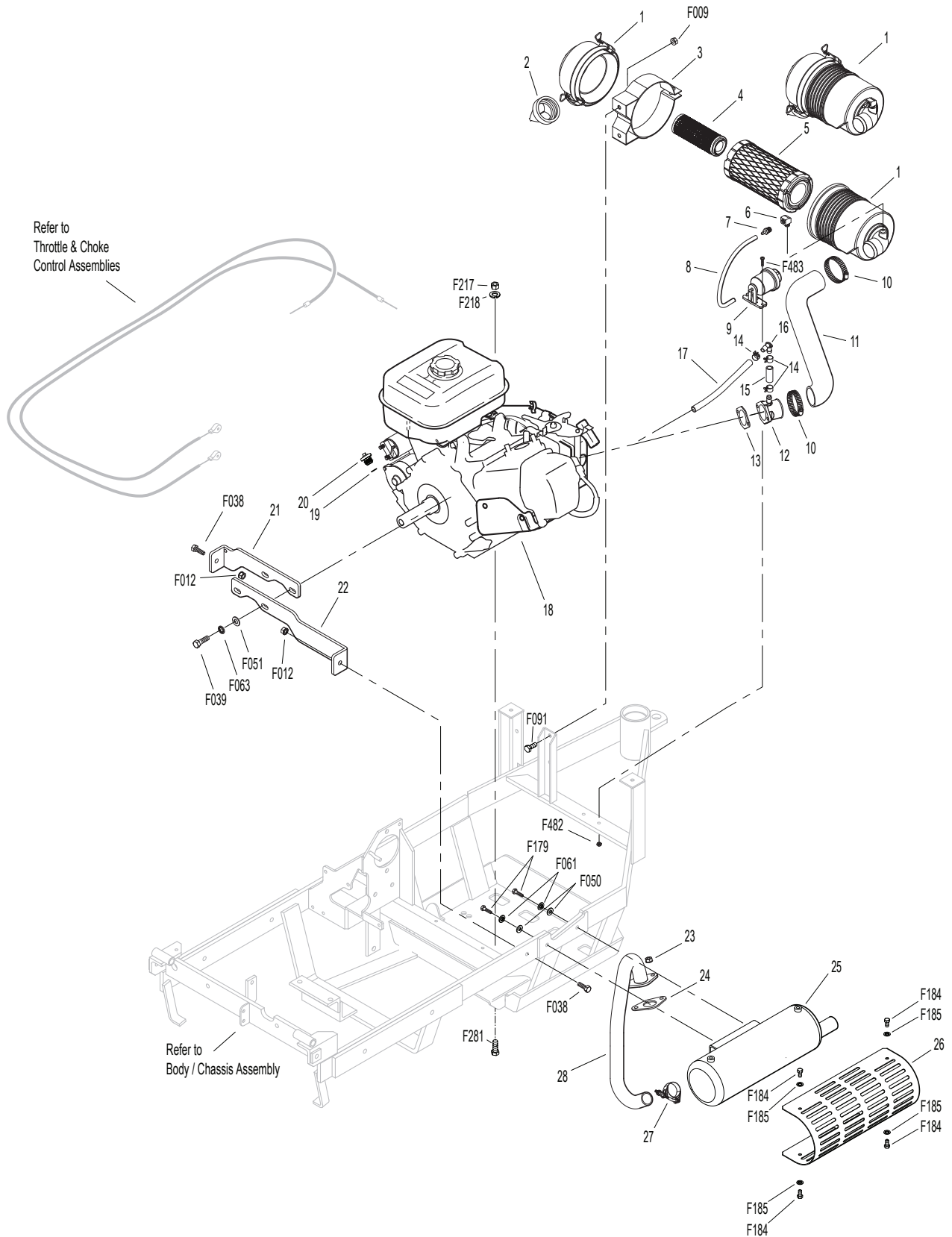

Beginning S/N 117172  
 Effective Date 05-04-12  
 Use only genuine **Walker**® replacement parts.

# HYDROSTATIC GROUND DRIVE ASSEMBLIES

ITEM NO.	PART NO.	DESCRIPTION	NO. REQ'D	ITEM NO.	PART NO.	DESCRIPTION	NO. REQ'D
<b>Transmission Lockout Assembly</b>				<b>Transmission Repair Parts</b>			
1	5028-3	Transmission Lockout Assembly (Includes Items # 2-5, F023, F027 & F081)	*	28	5025-5	Input Shaft	*
2	5847	Plastic Tip	2	29	5025-8	Bearing, Input Shaft	*
3	5057	Lockout Cam (Includes Item # F081)	2	30	5025-7	Snap Ring	*
4	5028-5	Lockout Lever	2	31	5025-2	Seal, Input Shaft	*
5	5027-5	Lockout Mount	2	32	5022	Reservoir to Casting Gasket	*
<b>Ground Drive Assemblies</b>				33	5024	Reservoir Cap and Gasket	*
6	5236-1	Transmission Drive Pulley (3-1/4 / A) (Includes Item # F171)	1	34	5023	Transmission Reservoir Kit	*
7	5209-5	Bridge	1	35	5023-1	Rubber Bladder	*
8	6832	Cable Clamp (9/16 x 1/4)	1	36	5025-6	O-Ring & Plug	*
9	6200-9	Gear Axle Drive Assembly (Includes Items # 13 & 14)	2	37	5025-3	Seal, Control Shaft	*
10	5025	Hydrostatic Drive, CCW (700-052)	1	<b>Fasteners</b>			
11	6243-2	Hydro Fan, CCW	1	F012	3/8-16 Keps Nut		1
12	5026	Hydrostatic Drive, CW (700-051)	1	F023	10-24 ESNA Nut		2
13	6206-1	Air Vent Valve	*	F027	10-24 x 5/8 PPHMS		2
14	6207-12	Pipe Plug (1/4 NPTF)	4	F036	1/4-20 x 1/2 SBH Screw		2
15	6233-1	Pinion Gear	2	F038	3/8-16 x 1 Hex Bolt		4
16	6234	Spacer, Pinion Gear	2	F040	3/8-16 x 1-1/2 Hex Bolt		4
17	6201	O-Ring Seal	2	F043	3/8-16 x 3 Hex Bolt		7
18	6244	Hydro Pulley (4/A) (Includes Items # F064 & F359)	2	F053	7/16 Internal Star Lock Washer		4
19	6243-1	Hydro Fan, CW	1	F063	3/8 Internal Star Lock Washer		16
20	5126	Cable Retainer (Uses existing bolt on Gear Axle Drive Assembly)	1	F064	1/8 x 1/2 Woodruff Key (#3)		4
<b>Deck Support Arm Assemblies</b>				F081	A/A45D Aluminum Pop Rivet		2
21	5830	Grease Fitting	2	F160	External Snap Ring (.669 Shaft)		2
22	6840-1	Support Arm Bushing (2-1/16)	2	F171	5/16-18 x 3/8 Set Screw		2
23	6430-10	Outboard Mount, LH	1	F178	1/4 x 1 Fender Washer		2
24	6431-1	Deck Support Arm, LH (Includes Item # 21)	1	F194	7/16 x 1-1/4 x 1/8 Washer		2
25	5775-2	Hitch Pin (# 6)	2	F200	7/16-20 x 3 Grade 8 Bolt		2
26	6431-2	Deck Support Arm, RH (Includes Item # 21)	1	F244	7/16-20 x 3/4 Hex Bolt		2
27	6430-9	Outboard Mount, RH	1	F262	3/8-16 x 4 Hex Bolt (Spec) All Thread		1
				F359	5/16-18 x 5/16 Set Screw (Unbrako Knurl Point)		4
				* Service Part Only			

# HYDROSTATIC GROUND DRIVE ASSEMBLIES

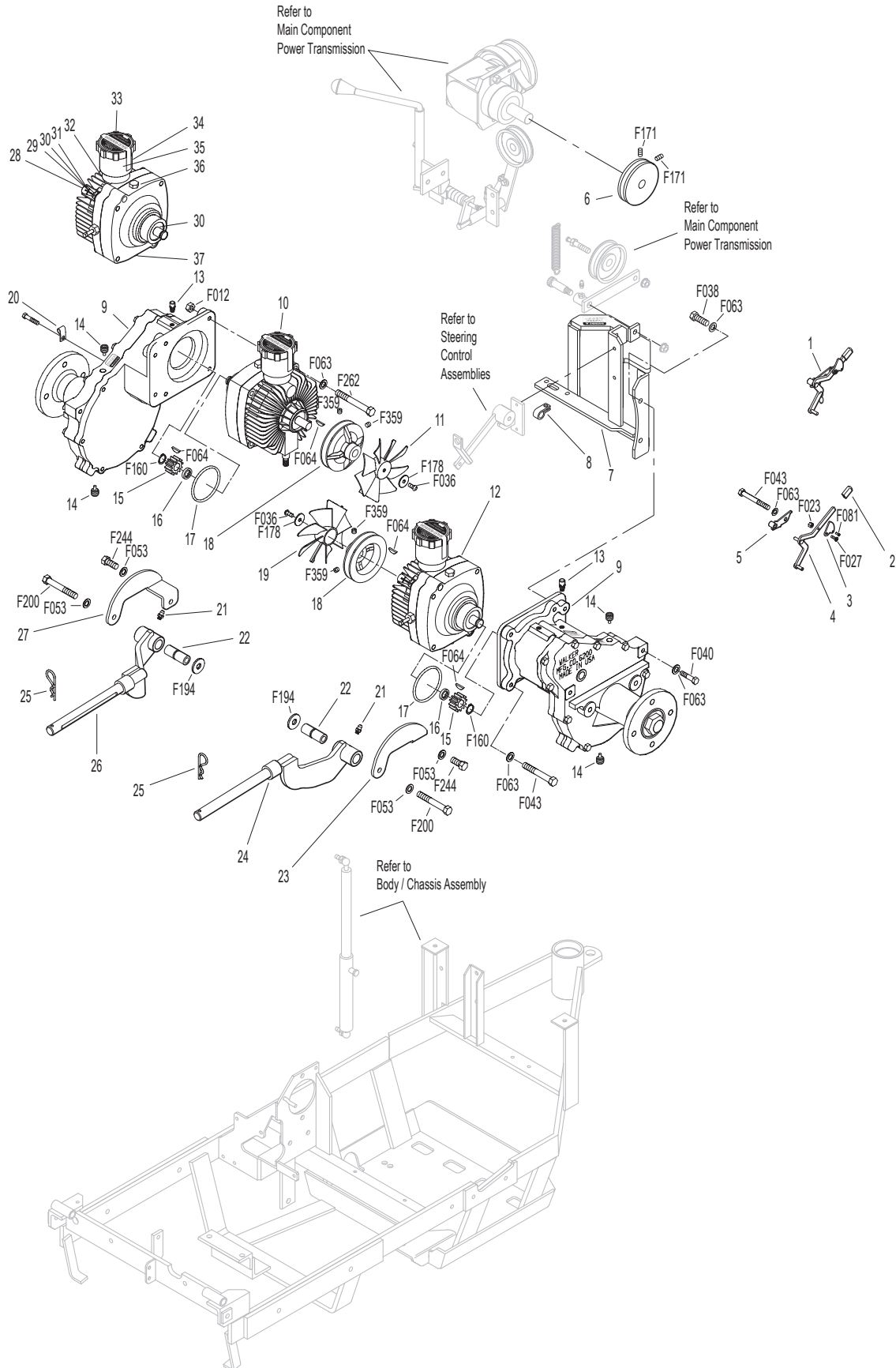

Beginning S/N 117172  
 Effective Date 05-04-12  
 Use only genuine **Walker®** replacement parts.

# PARKING BRAKE ASSEMBLY

ITEM NO.	PART NO.	DESCRIPTION	NO. REQ'D	ITEM NO.	PART NO.	DESCRIPTION	NO. REQ'D
<b>Parking Brake Assembly</b>				<b>Fasteners</b>			
1	7406-1	Handle Grip, Red	1	F003		1/4-28 Hex Nut	1
2	7406-8	Parking Brake Lever (4-1/4)	1	F004		1/4-20 Keps Nut	4
3	7406-2	Lever Mount	1	F029		1/4-20 x 1/2 Hex Bolt	3
4	5830	Grease Fitting	1	F032		1/4-20 x 3/4 Hex Bolt	1
5	7407	Clevis Pin (3/16 x 1/2)	2	F054		AN960616 Washer	2
6	7404	Brake Actuator Arm	2	F072		1/4 "E" Retainer Ring	2
7	7405	Pin, Transmission Lock	2	F086		#10 SAE Washer	4
8	7402	Clevis	2	F109		1/8 x 5/8 Roll Pin	2
9	7408	Compression Spring (1/2 x 3/4)	2	F111		1/8 x 3/4 Cotter Pin	1
10	7415	Rubber Dust Shield (5/8 x 3/8 x 1/32)	2	F112		5/8 x 1-1/4 x .03 Washer	2
11	5567-3	O-Ring (1/4 x 3/8)	4	F127		1/16 x 1/2 Cotter Pin	4
12	7403	Plunger Bushing, Gear Axle	2	F261		AN960616L Washer	5
13	7404-1	Brake Actuator Mount	2	F287		1/4-28 Keps Nut	1
14	7412	Clevis Pin (3/16 x 5/8)	2				
15	7410	Brake Control Cable, LH (25.5")	1				
16	7409	Brake Control Cable, RH (20.5")	1				
17	7401-3	Cable Mount Bracket	1				
18	7401-1	Cable Pull Rod	1				
19	5552	Ball Joint (1/4-28)	1				

# PARKING BRAKE ASSEMBLY

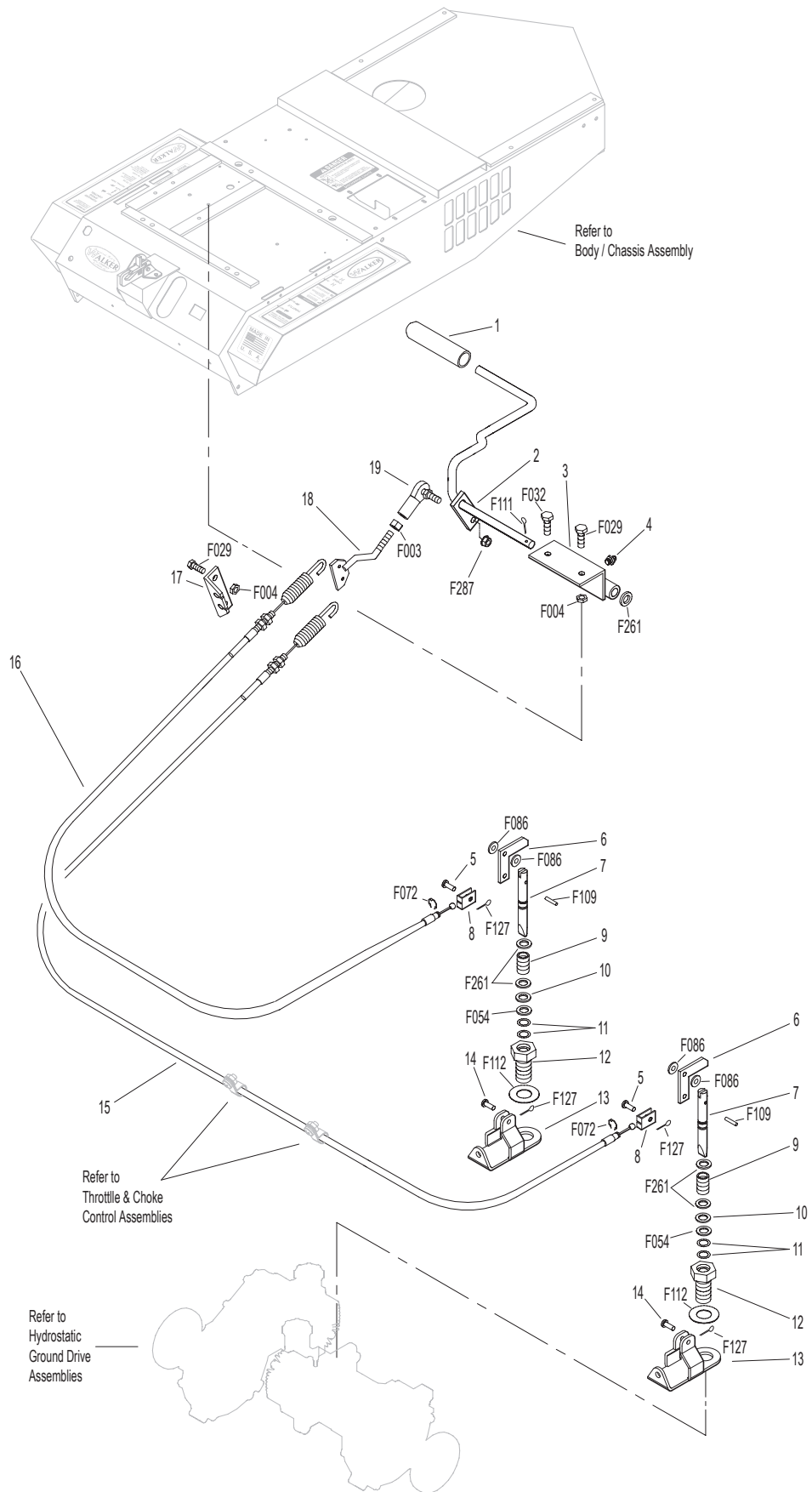

Beginning S/N 117172  
 Effective Date 05-04-12  
 Use only genuine Walker® replacement parts.



# STEERING CONTROL ASSEMBLIES

ITEM NO.	PART NO.	DESCRIPTION	NO. REQ'D	ITEM NO.	PART NO.	DESCRIPTION	NO. REQ'D
<b>Transmission Spring Assemblies</b>				30	5470-1	Speed Control Stop	1
1	6201-2	Shock Mount Gear Drive, RH	1	31	5450-10	Steering Lever Assembly, RH / Adjustable (Includes Items # 9, 10, 16, F360 & F489)	1
2	5146	10mm Ball Stud	4		5450-7	Steering Lever Arm, RH / Adjustable	*
3	5199-3	Steering Lever Dampener Assembly	2	32	5862	FSC Knob	1
4	6201-1	Shock Mount Gear Drive, LH	1	33	7170	FSC Lever Assembly (Includes Item # 16)	1
5	5214-2	Ball Joint (5/16-24) Nylon Lined	2	34	5975-3	Cable Tie (50# x 7")	1
6	6212-1	Transmission Control Arm, LH	1	<b>Fasteners</b>			
7	5213-3	Control Rod (6")	1		F003	1/4-28 Hex Nut	1
8	5665-1	Compression Spring (2-1/2)	2		F004	1/4-20 Keps Nut	6
9	5463-2	Steering Lever Actuator	2		F007	5/16-18 Jam Nut	1
10	7201-2	Fiberglide Bearing 1/2"	2		F008	5/16-24 Keps Nut	2
11	5213-4	Control Rod (14-3/4")	1		F009	5/16-18 Whiz Locknut	5
12	5212	Transmission Control Arm, RH	1		F010	5/16-24 ESNA Nut	2
<b>Steering Lever &amp; FSC Assemblies</b>					F012	3/8-16 Keps Nut	2
13	5173	FSC Actuator Rod	1		F024	5/16-24 Jam Nut	2
14	5172	Bearing, Delrin (.255 ID x .379 OD x .250)	1		F029	1/4-20 x 1/2 Hex Bolt	2
15	5142-2	FSC Actuator Cam	1		F032	1/4-20 x 3/4 Hex Bolt	4
16	5830	Grease Fitting	6		F034	5/16-18 x 3/4 Hex Bolt	1
17	5141	FSC Friction Washer (1-1/2 x 3/8 x 1/16)	2		F050	1/4 SAE Washer	3
18	5140	FSC Friction Body (Includes Item # 16)	1		F051	3/8 SAE Washer	2
19	5142-5	FSC Key	1		F064	1/8 x 1/2 Woodruff Key (#3)	2
	5140-3	FSC Control Assembly (Includes Items # 15-19, F192 & F193)	*		F068	1/8 x 1 Cotter Pin	1
20	5850-2	Handle Grip, Foam (5-1/2)	2		F069	3/32 x 1/2 Cotter Pin	1
21	5223	Extension Spring (1/4 x 5-1/2)	2		F093	5/16-18 x 1 Hex Bolt	1
22	5450	D-Clip	2		F183	.312 x .700 x .074 Washer	2
23	5391-3	Steering Lever Support	1		F186	5/64 x 1/2 Cotter Pin	1
24	5217	Pivot Pin, Steering Lever	1		F188	1/4-20 Self-Locking Nut	4
25	5451-10	Steering Lever Assembly, LH / Adjustable (Includes Items # 9, 10, 16, F360 & F489)	1		F192	3/8-24 Self-Locking Nut	1
	5451-7	Steering Lever Arm, LH / Adjustable	*		F193	3/8 Belleville Spring Washer	3
26	5453-10	Steering Lever Handle, Adjustable (Includes Items # 20 & F345)	2		F198	.250 x .625 x .040 Washer, SS	2
27	5219	Extension Spring (3/4 x 6-3/4)	1		F345	1/4-20 x .770 Knurled Bolt	4
28	5280	Clevis (1/4")	1		F360	1/4-20 x 3/8 Hex Bolt	2
29	5281-5	Clevis Pin (1/4 x 0.80)	1		F401	.504 x .751 x .030 Washer	1
					F489	Washer 1/4 x 7/8 x .090	2
				*	Service Part Only		



# STEERING CONTROL ASSEMBLIES

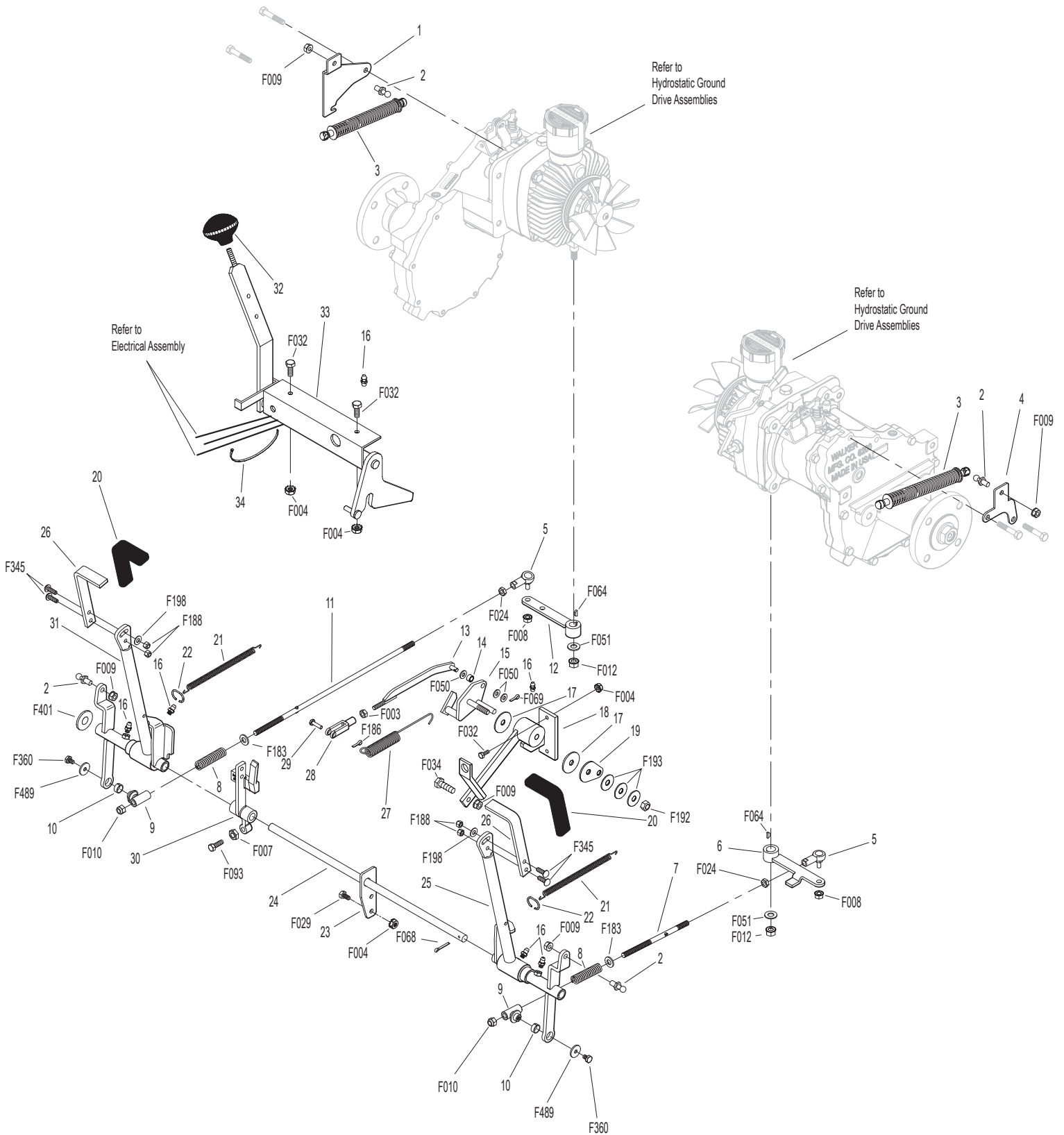

Beginning S/N 117172  
 Effective Date 05-04-12  
 Use only genuine Walker® replacement parts.

# THROTTLE & CHOKE CONTROL ASSEMBLIES

ITEM NO.	PART NO.	DESCRIPTION	NO. REQ'D	ITEM NO.	PART NO.	DESCRIPTION	NO. REQ'D
<b>Throttle &amp; Choke Control Assemblies</b>				<b>Fasteners</b>			
1	5121-2	Throttle Cable	1		F002	10-24 Keps Nut	8
2	5122-2	Choke Cable	1		F005	1/4-20 ESNA Nut	2
3	5975-1	Cable Tie (18# x 3-3/4")	3		F025	10-24 x 3/8 PPHMS	6
4	7108	Control Assembly, Throttle and Choke (Includes Items # 6, 7, 9-11 & F201)	*		F050	1/4 SAE Washer	2
	5121	Throttle Control and Cable Assembly (Complete Control and Cable Assembly)	*		F164	10-24 x 1/4 x 3/8 SHL Bolt	2
	5122	Choke Control and Cable Assembly (Complete Control and Cable Assembly)	*	*	F201	1/4 Belleville Spring Washer	4
5	5108-6	Choke Control Knob, Black	1				
6	5108-8	Control Bracket	2				
7	5108-11	Friction Washer (.062)	2				
8	5108-5	Throttle Control Knob, Red	1				
9	5108-1	Control Lever, Throttle and Choke	2				
10	5108-10	Friction Washer (.125)	2				
11	5108-7	Control Lock Tab	2				
12	5172	Bearing, Nylon (.255 x .379 x .250)	2				
13	5126	Cable Retainer	2				

\* Service Part Only

# THROTTLE & CHOKE CONTROL ASSEMBLIES

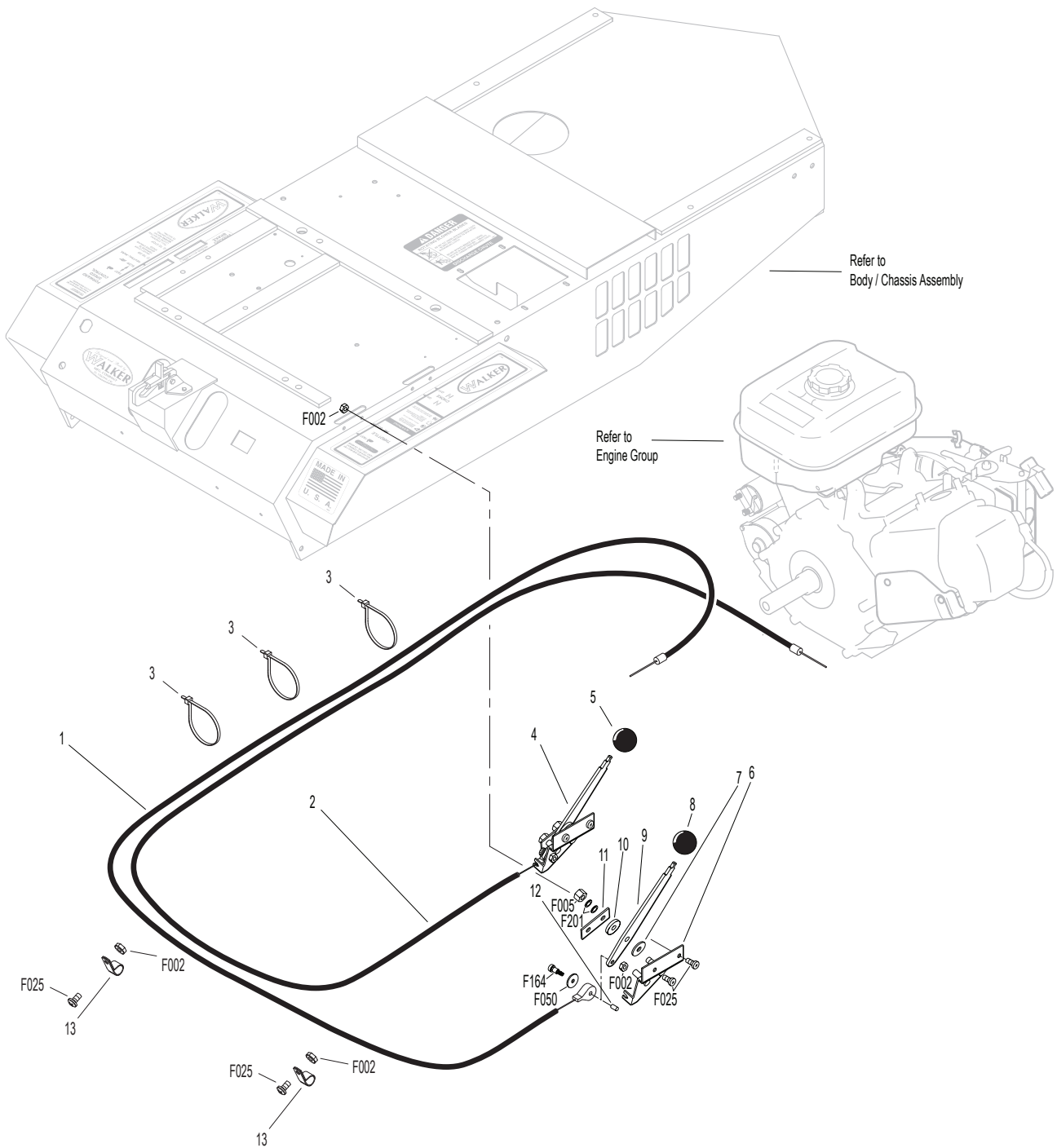

Beginning S/N 117172  
Effective Date 05-04-12  
Use only genuine Walker® replacement parts.

# GHS GROUP

ITEM NO.	PART NO.	DESCRIPTION	NO. REQ'D	ITEM NO.	PART NO.	DESCRIPTION	NO. REQ'D
<b>Delivery Chute Assembly</b>				<b>Fasteners</b>			
1	5515-2	Elbow Delivery Spout	1	F002		10-24 Keps Nut	6
2	5592-13	Backing Plate, Grass-Pak® Switch	1	F004		1/4-20 Keps Nut	9
3	5578	Rear Clip, Chute Mount	1	F009		5/16-18 Whiz Locknut	1
4	5577	Side Clip, Chute Mount	2	F012		3/8-16 Keps Nut	2
5	5511-3	6.7 Delivery Chute W/Clips (Includes Items # 6, F362 & F411)	1	F025		10-24 x 3/8 PPHMS	4
6	5578-10	Front Clip, Chute Mount	1	F026		10-24 x 1/2 PPHMS	2
7	6530-4	Body Chute (10")	1	F031		1/4-20 x 5/8 Hex Bolt	1
<b>Blower Assembly</b>				F034		5/16-18 x 3/4 Hex Bolt	1
8	5239-2	Blower Pulley, Offset Hub (Includes Items # F067 & F114)	1	F038		3/8-16 x 1 Hex Bolt	2
9	5238-2	PTO Drive Pulley (5 / B) (Includes Items # F075 & F114)	1	F067		3/16 x 3/16 x 1 Key	1
10	5234-2	GHS PTO Belt (B41 / #6944)	1	F075		5/16-18 x 1/2 SQH Set Screw	3
11	5268	Bearing (3/4) Includes Locking Collar	2	F090		1/4-20 x 2-1/2 Hex Bolt	1
12	6545	Blower Wheel (10")	1	F114		5/16-18 x 5/8 SQH Set Screw	1
13	6525-2	Faceplate (10" Blower)	1	F132		1/4-20 x 2-3/4 Hex Bolt	1
14	6526-2	Intake Tube With Slots (6-1/2 x 2-1/2)	1	F362		A/A62D Alum. Pop Rivet (3/16D x 13/32L)	2
15	5595-2	Intake Cover	*	F411		3/16 Bulbex Rivet	6
16	6543	Blower Housing (10")	1	F504		1/4-20 Whiz Locknut	6
	6542	Blower Assembly (10") (Includes Items # 11-14, 16 & F504)	**	* Plugs Blower when GHS is not in use. Furnished only with Mulching Decks, SD Decks used on a GHS Tractor, Rotary Broom Attachment and Snowblower Attachment.			
17	5014-5	Belt Guide	1	** Service Part Only			
18	5534-2	Skid Bar (10" Blower)	1	<b>NOTE:</b> Refer to <b>ELECTRICAL CONNECTORS</b> , Page 28, for identification of all Electrical Wiring Service Parts.			

# GHS GROUP

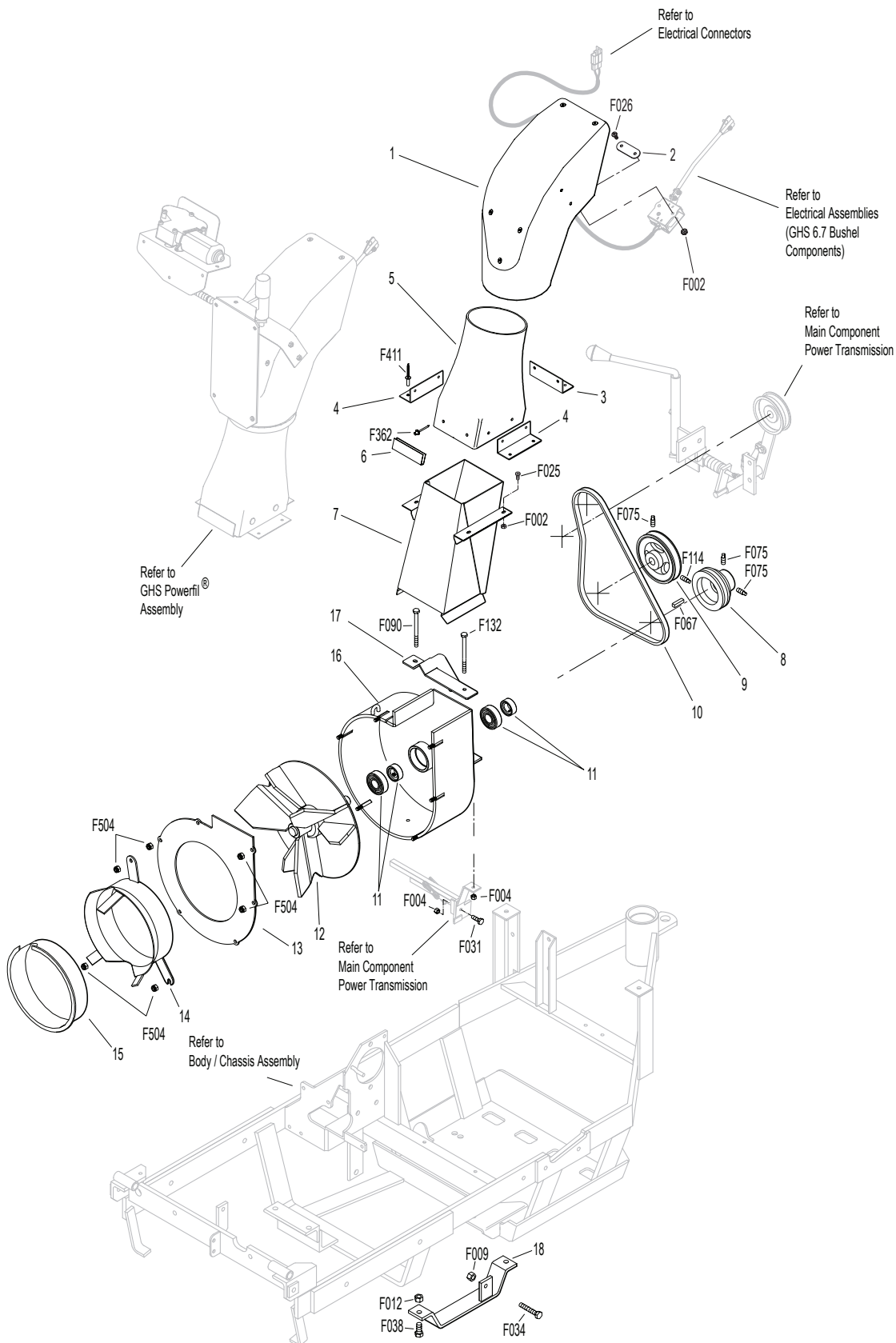

Beginning S/N 117172  
 Effective Date 05-04-12  
 Use only genuine **Walker**® replacement parts.

# GHS POWERFIL® ASSEMBLY

ITEM NO.	PART NO.	DESCRIPTION	NO. REQ'D	ITEM NO.	PART NO.	DESCRIPTION	NO. REQ'D
<b>GHS Powerfil® Assembly</b>				<b>Fasteners</b>			
1	5557-1	Motor Mount, Powerfil®	1	F002		10-24 Keps Nut	11
2	5551-3	Bearing Cap, Powerfil®	1	F003		1/4-28 Hex Nut	3
3	5551-1	Pivot Bearing (#S3PP)	2	F025		10-24 x 3/8 PPHMS	1
4	5552	Ball Joint (1/4-28)	2	F037		10-24 x 5/8 PTH Screw	1
5	5518-2	Pivot, Delivery Spout	1	F054		AN960616 Washer	1
6	5517-2	Pivot Mount	1	F061		1/4 Star Lock Washer	1
7	5558-1	Powerfil® Push Rod	1	F085		3/16 Rivet Backup Washer	1
8	5553-3	Bushing, Powerfil® Actuator	4	F101		10-24 x 1-1/4 SHC Screw	1
9	5558-2	Powerfil® Actuator Rod	1	F109		1/8 x 5/8 Roll Pin	1
	5549	Actuator Rod Assembly (Includes Items # 4, 7-10 & F003)	*	F129		10-24 x 1/2 PTHMS	7
10	5553-1	Compression Spring (1/2 x 2)	2	F261		AN960616L Washer	1
11	5554	Actuator Arm	1	F287		1/4-28 Keps Nut	2
12	5519-3	Motor Mount Nut (5/8-24)	*	* Service Part Only			
13	5519-2	Motor Mount Washer	*				
14	5519-5	Actuator Motor (12V) (Includes Items # 12 & 13)	1				
15	5977-1	Grommet (1/8 x 3/8)	1	<b>NOTE:</b> Refer to <b>ELECTRICAL CONNECTORS</b> , Page 28, for identification of all Electrical Wiring Service Parts.			

# GHS POWERFIL® ASSEMBLY

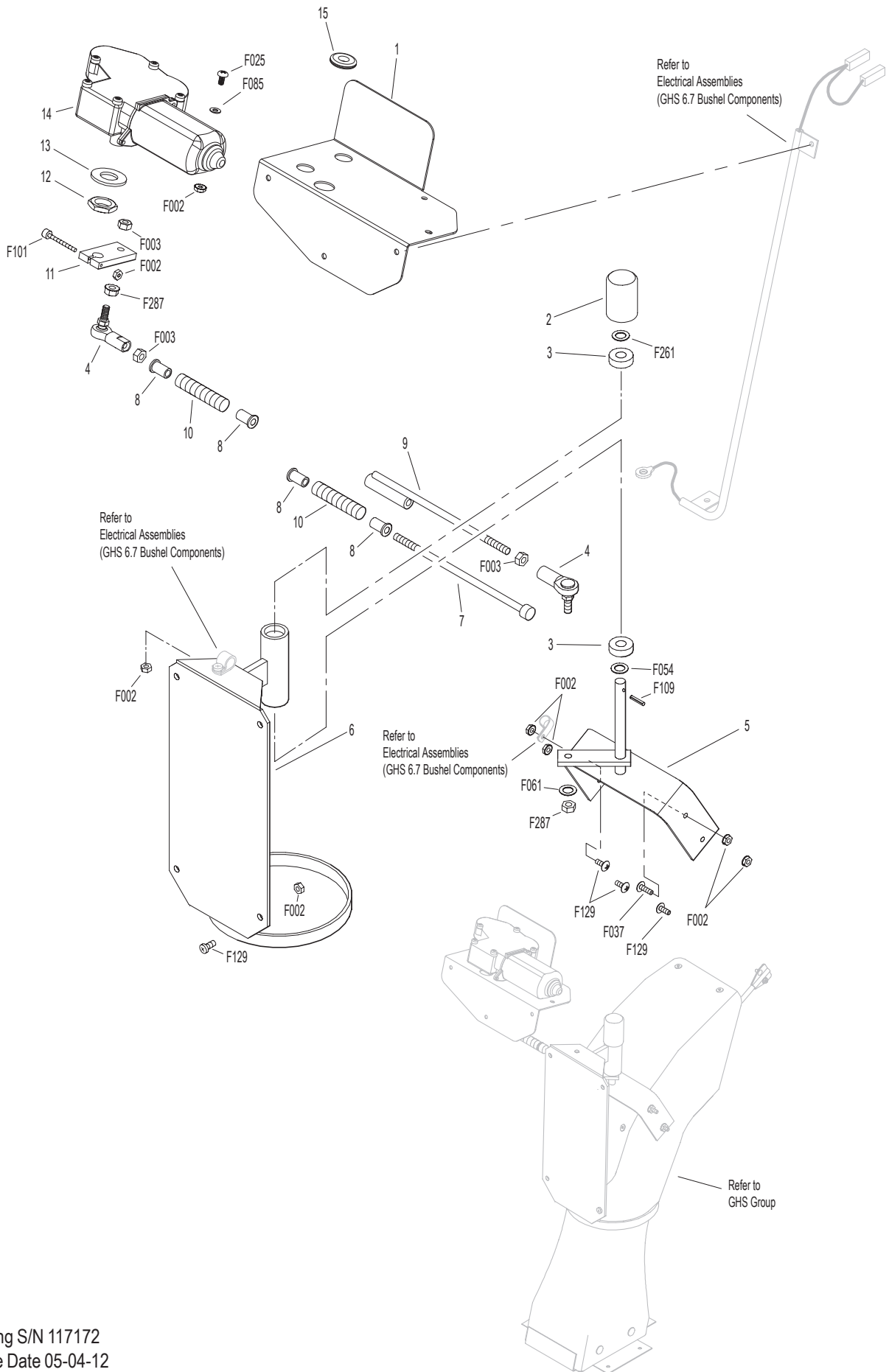

Beginning S/N 117172  
 Effective Date 05-04-12  
 Use only genuine **Walker®** replacement parts.

# GHS 6.7 BUSHEL CATCHER & EXHAUST DEFLECTOR ASSEMBLIES

ITEM NO.	PART NO.	DESCRIPTION	NO. REQ'D
<b>Upper Baffle Screen Assembly (Removable)</b>			
1	7509-3	Channel Bottom	2
2	7505	Mustache Spring	2
3	6507	Screen Seal (24")	1
4	6856-1	Edge Molding (21-3/4)	1
5	7509-2	Channel Top	2
6	6512-2	Removable Screen (3/16 Hole) (Includes Items # 4, 7, F025 & F190)	1***
7	7506	Knob, Threaded Insert (10-24)	2
8	6509-4	C-Channel (6.7)	1
<b>Exhaust Deflector Assembly</b>			
	5504	Exhaust Deflector Kit, 6.7	*
9	5504-3	Hinge (22")	1
10	5504-1	Exhaust Deflector (2 Piece / 6.7)	1
11	5504-8	Deflector Mount Doubler	2
<b>GHS 6.7 Bushel Catcher Assembly</b>			
12	5583	Handle	1
13	5588	Rubber Bumper (.75 x .50)	2
14	5130	Side Strap, Door (6.7)	2
15	5514-10	6.7 Door Frame, Gas Spring	1
16	5510-1	6.7 Bushel Catcher, with Door	1
	5502-1	6.7 Catcher, W/O Powerfil® (Includes Door & Deflector)	**
	5502-2	6.7 Catcher W/ Powerfil® (Includes Door & Deflector)	**
17	5503	6.7 Mounting Frame	1
18	5513-1	6.7 Mounting Frame Doubler	1
19	6610-1	Catcher Dump Plate	1
	6611	Dump Plate Kit (Includes Items # 19-21, F069 & F228)	**
20	7610-1	Dump Plate Slide	2
21	5281-5	Clevis Pin (1/4 x 0.80)	1
22	5512-10	Deflector Seal, 6.7	1
23	5522-1	Hinge Backup Plate, LH	1
24	5155-12	5/16 Ball Stud	2
25	5147	Spring Clip	4
26	5155-2	Gas Spring Cover	2
27	5155	Gas Spring Assembly / Catcher Door (Includes Items # 24, 25, 29 & F049)	2
28	5524-1	Flanged Hinge Bearing	2
29	5155-13	3/4 Ball Stud	2
30	5523-6	Gas Spring Plate	2
31	7532	Handle, Catcher Lift	2
	7534	Catcher Handle Kit (Includes Items # 31, 32, F004 & F172)	*
32	7533	Backing Plate, Handle	2

ITEM NO.	PART NO.	DESCRIPTION	NO. REQ'D
33	5155-15	Box Support, Gas Spring	2
34	6508	Safety Latch Hinge	1
35	5522-2	Hinge Backup Plate, RH	1
36	5584	Reinforcing Strap	2
<b>5598 Optional Dump Bag (Not Shown)</b>			
May be ordered as an option. Contact your Walker dealer.			
<b>Fasteners</b>			
	F002	10-24 Keps Nut	23
	F004	1/4-20 Keps Nut	16
	F009	5/16-18 Whiz Locknut	2
	F020	5/16-18 ESNA Nut	2
	F025	10-24 x 3/8 PPHMS	4
	F026	10-24 x 1/2 PPHMS	8
	F027	10-24 x 5/8 PPHMS	4
	F035	5/16-18 x 1-1/4 Hex Bolt	1
	F037	10-24 x 5/8 PTH Screw	4
	F049	5/16 SAE Washer	5
	F069	3/32 x 1/2 Cotter Pin	1
	F079	A/A66D Aluminum Pop Rivet	11
	F085	3/16 Rivet Backup Washer	21
	F129	10-24 x 1/2 PTHMS	4
	F172	1/4-20 x 3/4 Carriage Bolt	4
	F188	1/4-20 Self Locking Nut	17
	F190	#10 Internal Star Lock Washer	2
	F195	1/4-20 x 3/4 PPHMS, SS	8
	F196	1/4-20 x 1 PPHMS, SS	2
	F198	.250 x .625 x .040 Washer, SS	9
	F203	1/4-20 x 5/8 PPHMS, SS	4
	F228	#6 x 5/8 PPHSMS, SS	1
	F230	1/4-20 x 1-1/4 PPHMS, SS	1
	F242	1/4-20 x 7/8 PPHMS, SS	14
	F252	10-24 x 3/4 PPHMS	1
	F255	5/16-18 x 1-1/2 Hex Bolt	1
	F329	.200 ID x 1.939 OD Washer	2
	F330	3/16 D x 21/32 L Rivet, SS	2
	F351	Aluminum Pop Rivet	6

\* This kit is sold as a complete assembly, including mounting hardware.

\*\* Service Part Only

\*\*\* This screen can be replaced by P/N 6512-3 Removable Screen (3/4" holes) for improved air flow performance in wet conditions.





# ELECTRICAL ASSEMBLY

ITEM NO.	PART NO.	DESCRIPTION	NO. REQ'D	ITEM NO.	PART NO.	DESCRIPTION	NO. REQ'D
<b>Battery Assembly</b>				24	6941-7	Relay Mount	*
1	5932	Battery Terminal Insul., Black (-)	1	25	6941-6	Relay Switch 30/40AMP	*
2	5975-1	Cable Tie (18# x 3-3/4")	3	26	NS	Bolt (Subaru)	1
3	5933	Battery Terminal Insul., Red (+)	1	27	5961	Fuse Holder Mount Bracket	1
4	NS	Battery (12V/300.CA/Wet)	1	28	6941-1	20 Amp Fuse	*
5	5844	Battery Hold-Down Bar	1	29	5940-6	Fuse Holder with Terminals	*
6	6392	Battery Protector Plate	1	30	NS	Voltage Regulator (Subaru)	1
7	5839	Hook Bolt	2	<b>Fasteners</b>			
8	6390	Battery Pan	1	F002	10-24 Keps Nut		1
9	6923	Battery Cable (-)	1	F004	1/4-20 Keps Nut		7
<b>Electrical Assembly</b>				F009	5/16-18 Whiz Locknut		1
10	8960-15	Ignition Switch (with Keys) (Includes Items # 20, 21 & F349)	1	F019	1/4-20 ESNA Wing Nut		2
11	5941-1	Switch Boot (Fits P/N 5941)	2	F025	10-24 x 3/8 PPHMS		1
12	5941	Safety Switch (Normal Closed) (Includes Item # 11)	2	F031	1/4-20 x 5/8 Hex Bolt		2
13	5975-3	Cable Tie (50# x 7")	3	F032	1/4-20 x 3/4 Hex Bolt		3
14	5942	Safety Switch (Normal Open) (Includes Item # 15)	3	F050	1/4 SAE Washer		5
15	5942-1	Switch Boot (Fits P/N 5942)	3	F093	5/16-18 x 1 Hex Bolt		1
16	5991-1	Hourmeter Power Lead Wire	1	F179	1/4-20 x 1 Hex Bolt		2
17	8990-1	Hourmeter (Global)	1	F349	Washer .835 ID 1.122 OD, SS		1
18	5991-2	Hourmeter Ground Wire	1	* Service Part Only			
19	5940-3	Ignition Switch Cover	1	<b>NOTE:</b> Refer to <b>ELECTRICAL CONNECTORS</b> , Page 28, for identification of all Electrical Wiring Service Parts.			
20	8960-3	Key Set W/Umbrella	1	<b>NOTE:</b> Decals for this assembly are not shown here. Refer to <b>TRACTOR DECALS</b> , Page 2, for Decal listing and placement information.			
21	7854	Plastic Tip / Red	1				
22	5943-3	Wire Harness Assembly	1				
23	6942	Relay Switch (30/40 Amp) NC (Includes Items # 24 & 25)	1				

# ELECTRICAL ASSEMBLY

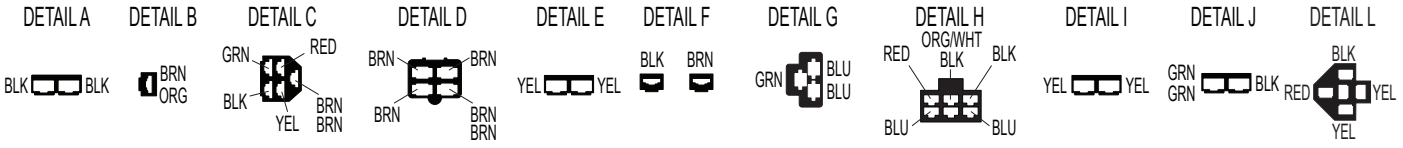
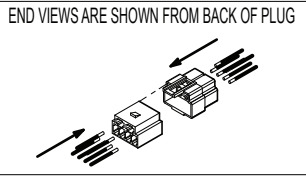
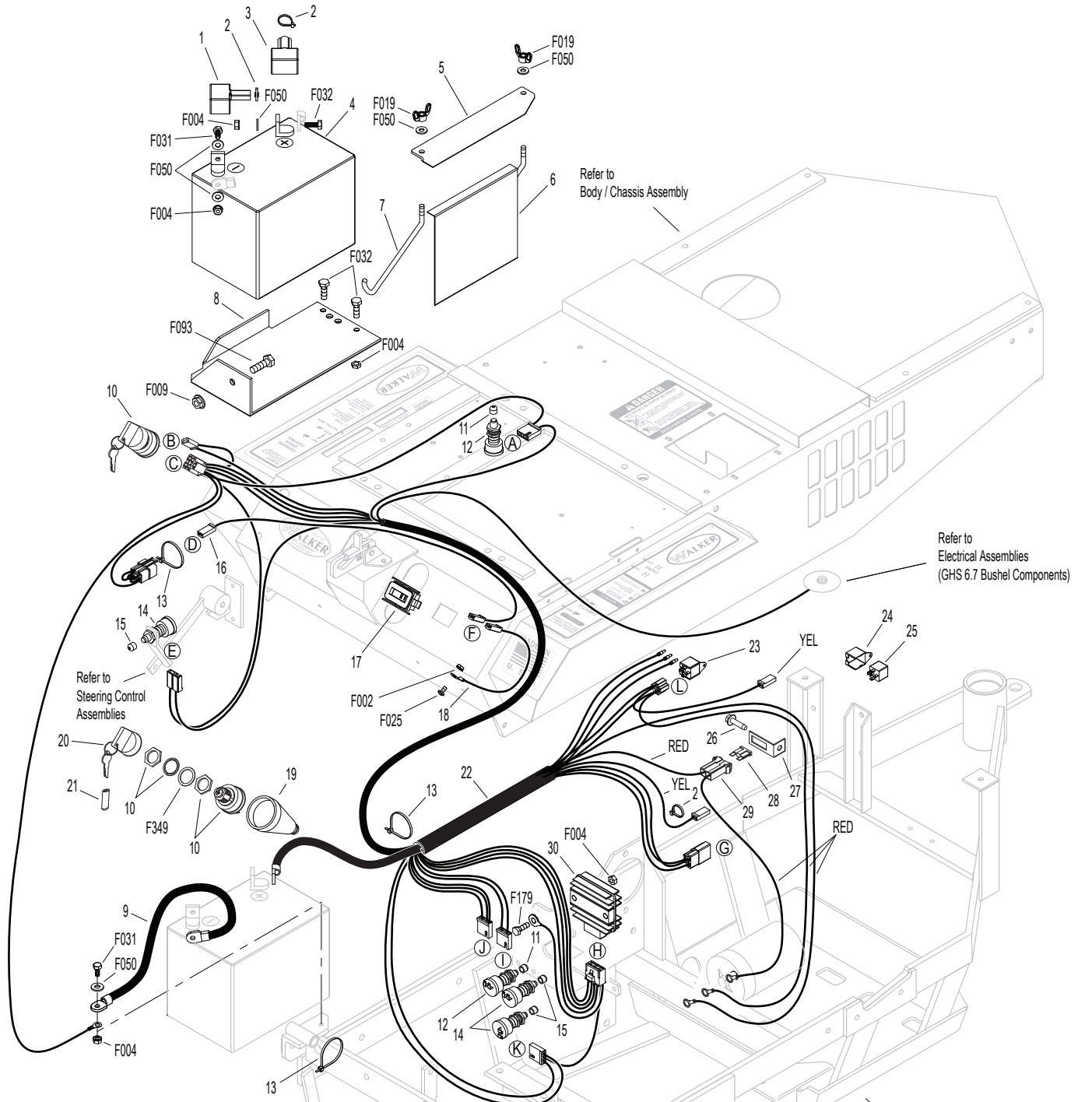

Beginning S/N 117172  
 Effective Date 05-04-12  
 Use only genuine **Walker®** replacement parts.

# ELECTRICAL ASSEMBLIES (GHS 6.7 BUSHEL COMPONENTS)

ITEM NO.	PART NO.	DESCRIPTION	NO. REQ'D
----------	----------	-------------	-----------

## Horn & Powerfil® Wiring Assemblies

1	5519-4	Adapter Harness	1
2	5599	Pigtail Wire Set, Horn	1
3	5857	Wire Clamp (1/8 J-Clip)	1
4	5975-3	Cable Tie (50# x 7")	1
5	5536-2	Horn, Full Signal	*
6	5984	Electric Contact Spring	2
7	5982-2	Insulator Bushing	1
8	5982-1	Insulator Washer (2")	1
9	5985-2	Power Lead Wire (6.7)	1
10	5988-1	Conduit Assembly, Powerfil® Wiring	1
	5988-4	Powerfil® Tube & Wire Assembly (Includes Items # 9 & 10)	*

## Grass-Pak® Switch Assembly

11	5594-5	Vane Assembly, Grass-Pak® Switch	1
12	5592-3	Grass-Pak® Vane Arm	1
13	5592-14	Grass-Pak® Switch Assembly	1
14	5833	Cable Clamp (1/4)	2

ITEM NO.	PART NO.	DESCRIPTION	NO. REQ'D
----------	----------	-------------	-----------

## Fasteners

F002	10-24 Keps Nut	12
F025	10-24 x 3/8 PPHMS	1
F037	10-24 x 5/8 PTH Screw	1
F085	3/16 Rivet Backup Washer	1
F086	#10 SAE Washer	1
F129	10-24 x 1/2 PTHMS	3
F147	10-24 x 1/2 PPHMS, SS	3
F148	10-24 x 3/8 PPHMS, SS	3
F508	4-40 Keps Nut, SS	2
F509	4-40 x 1/2 Hex Head, SS	2

\* Service Part Only

**NOTE:** Refer to **ELECTRICAL CONNECTORS**, Page 28, for identification of all Electrical Wiring Service Parts.

# ELECTRICAL ASSEMBLIES (GHS 6.7 BUSHEL COMPONENTS)

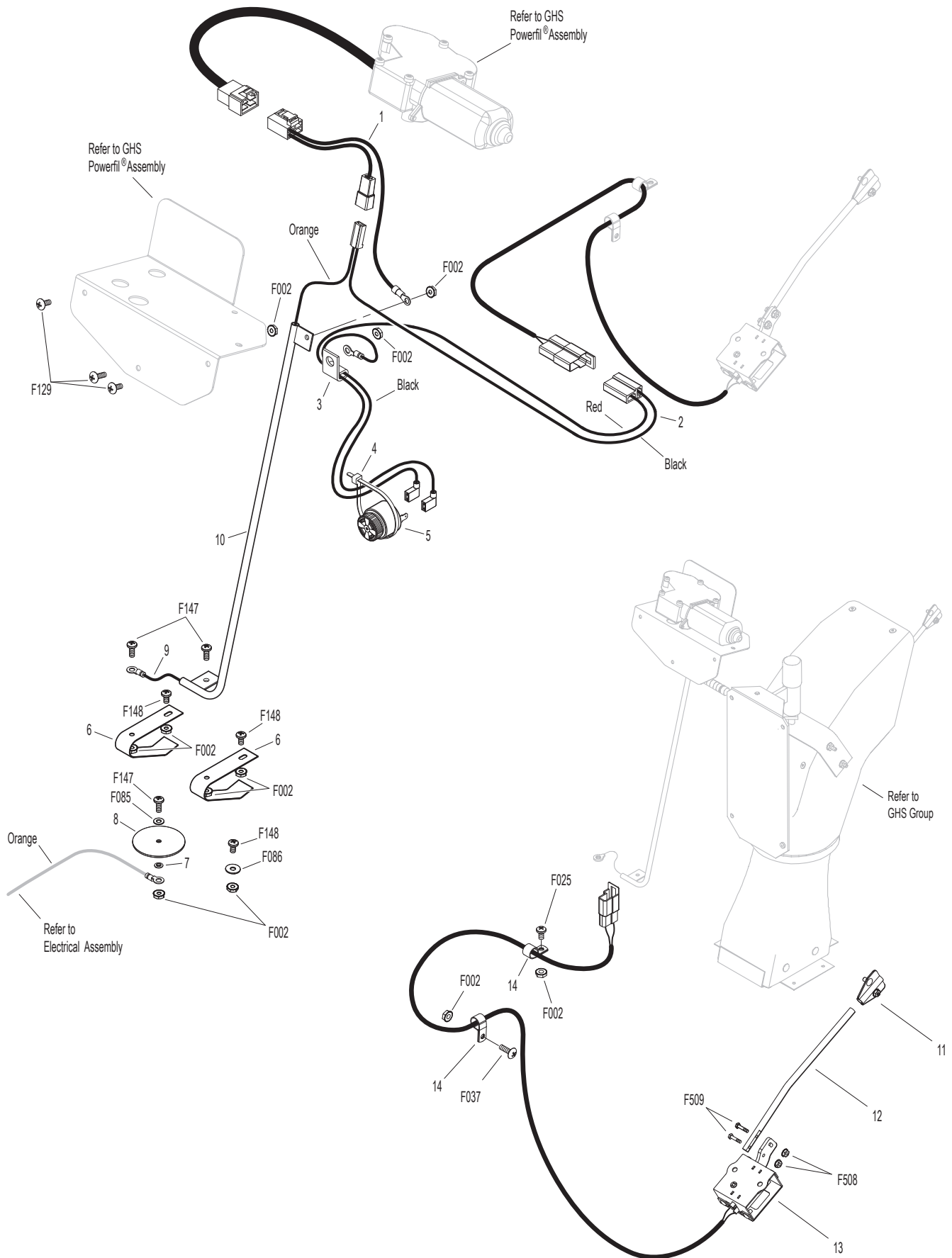

Beginning S/N 117172  
 Effective Date 05-04-12  
 Use only genuine Walker® replacement parts.

# ELECTRICAL CONNECTORS

ITEM NO.	PART NO.	DESCRIPTION	NO. REQ'D	ITEM NO.	PART NO.	DESCRIPTION	NO. REQ'D
<b>Electrical Wiring Service Parts</b>				29	7942-1	2-Way Locking Connector, Female	*
1	5996-1	16-14 GA Butt Connector	*	30	7942-2	2-Way Connector, Male	*
2	5996-11	12-10 GA Butt Connector	*	31	7942-3	2-Way Connector, Female	*
3	7942-14	16-14 GA Shrink Connector	*	32	7942-10	2-Way Locking Connector, Male	*
4	7942-13	12-10 GA Shrink Connector	*	33	5940-8	3-Way Connector, Male	*
5	5995-1	Wire Terminal Adapter	*	34	7942-9	3-Way Connector, Male	*
6	5996-4	16-14 GA Bullet Conn., Male	*	35	8944	3-Way Locking Connector, Male	*
7	5996-5	16-14 GA Bullet Conn., Female	*	36	8944-1	3-Way Locking Connector, Female	*
8	5940-4	16-14 GA Spg. Loaded Term., Female	*	37	7942-11	4-Way Connector, Male	*
9	5940-7	Wire Clip, Female	*	38	7942-12	4-Way Connector, Female	*
10	5996	1/4 x 16-14 GA QKS Term., Female	*	39	7942-5	5-Way Connector, Male	*
11	5996-2	3/16 x 22-18 GA QKS Term., Female	*	40	5940-2	5-Way Connector, Male	*
12	7996	16-14 GA QKS Term., Female	*	41	8942-1	5-Way Connector, Female	*
13	5940-5	16-14 GA Spg. Loaded Term., Male	*	42	7942-6	6-Way Connector, Male	*
14	5996-0	1/4 x 22-18 GA QKS Term., Male	*	43	7942-7	6-Way Connector, Male	*
15	5996-18	16-14 GA Ring Term. (#8) Nylon Insulated	*	44	7942-8	8-Way Connector, Male	*
16	7996-1	1/4 x 16-14 GA QKS Term., Male	*	45	8942-2	8-Way Connector, Female	*
17	5996-8	6 GA Ring Lug (5/16)	*	46	8942-3	5-Way Connector, Male	*
18	5996-9	22-18 GA Ring Term., #10	*	47	5940-9	3-Way Connector (M)	*
19	5996-10	16-14 GA Ring Term. (5/16)	*	48	7942-15	6-Way Connector (Female)	*
20	5996-12	12-10 GA Ring Term. (5/16)	*	49	7940-3	Packard Plug (Male)	*
21	5996-13	16-14 GA Ring Term., # 10	*	50	7940-4	Packard Plug (Female)	*
22	5996-15	12-10 GA Ring Term. (1/2)	*	* Service Part Only			
23	5996-16	6 GA Ring Terminal (1/4)	*	<b>NOTE:</b> Not all Electrical Connectors are used with all assemblies.			
24	5996-17	16-14 GA Ring Term. (1/4)	*	<b>NOTE:</b> Refer to <b>ELECTRICAL ASSEMBLY</b> , Page 24, for locations of Wiring Harness, Electrical Components and of all Electrical Wiring Service Parts.			
25	5996-20	12-10 GA Ring Term. (1/4)	*				
26	5996-21	12-10 GA Ring Term., #10	*				
27	7942-4	Single Connector, Male	*				
28	8942	2-Way Connector, Male	*				

# ELECTRICAL CONNECTORS

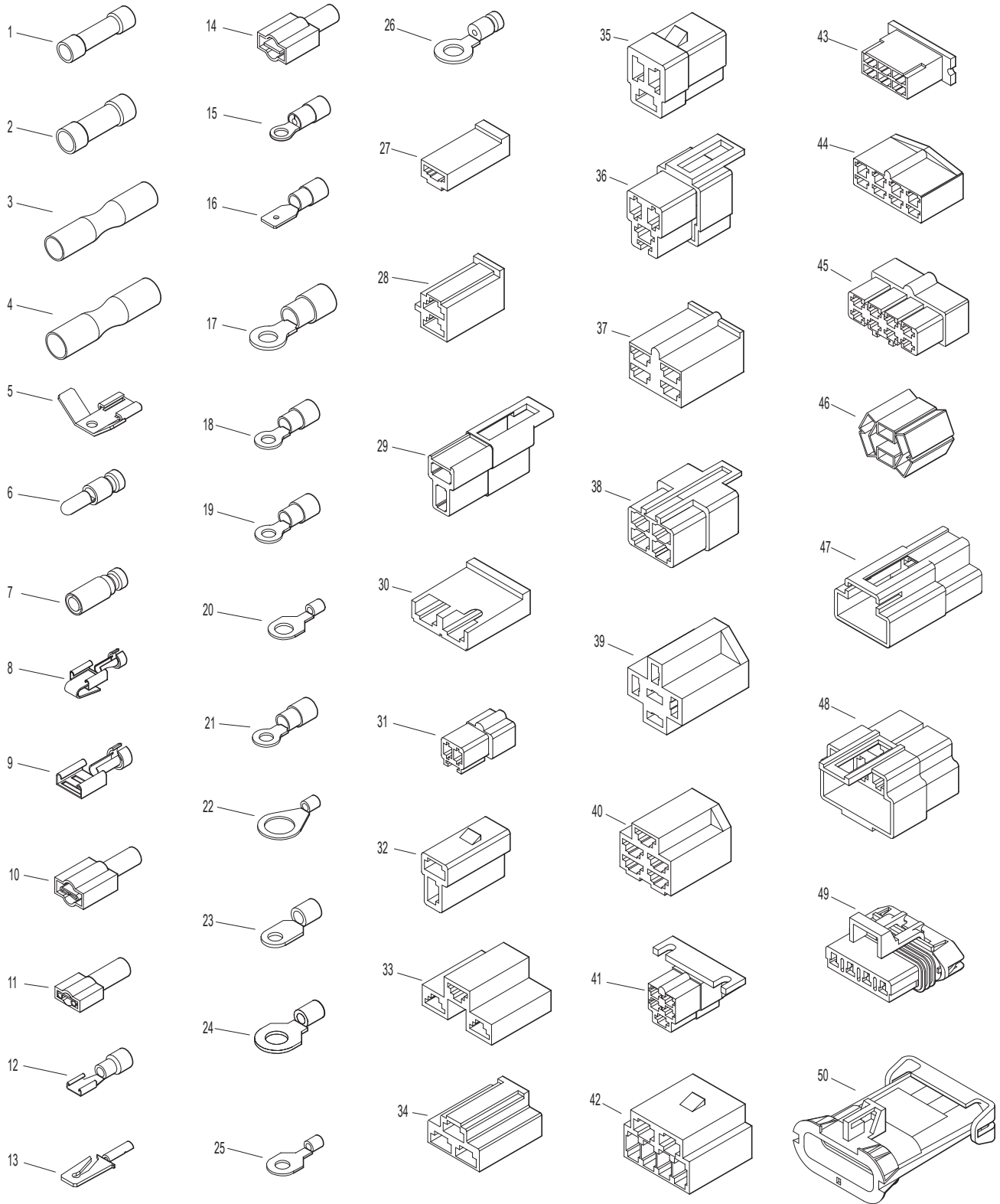

Beginning S/N 117172  
Effective Date 05-04-12  
Use only genuine Walker® replacement parts.



## ARMREST KIT / TOUCH-UP PAINT

ITEM NO.	PART NO.	DESCRIPTION	NO. REQ'D
----------	----------	-------------	-----------

**Kit 5885 Armrest Option / Kit**

Includes Items # 1-5, fasteners listed and instructions. May be ordered as a dealer-installed option. Contact your Walker dealer.

1	5886-1	Armrest, RH	1
2	5886-6	Cover Plate, RH	1
3	5887	Mounting Bracket	1
4	5886-5	Cover Plate, LH	1
5	5886-2	Armrest, LH	1
	5888	Armrest Hardware Kit (Includes Items # F305, F306, F307 & F308)	*

ITEM NO.	PART NO.	DESCRIPTION	NO. REQ'D
----------	----------	-------------	-----------

**Touch-Up Paint**

6	5866	Touch-Up Paint, Yellow (12 oz. Aerosol)	
7	5867	Touch-Up Paint, Grey (12 oz. Aerosol)	

**Fasteners**

F305	1/4-20 x 3/8 SH Cap Screw	2
F306	3/8-16 x 3/4 Hex Bolt	4
F307	#10 x 5/8 PPHST Screw	2
F308	1-1/4 x 1-5/8 Wave Spring Washer	2

\* Service Part Only



# ARMREST KIT / TOUCH-UP PAINT

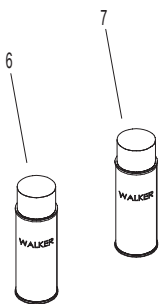
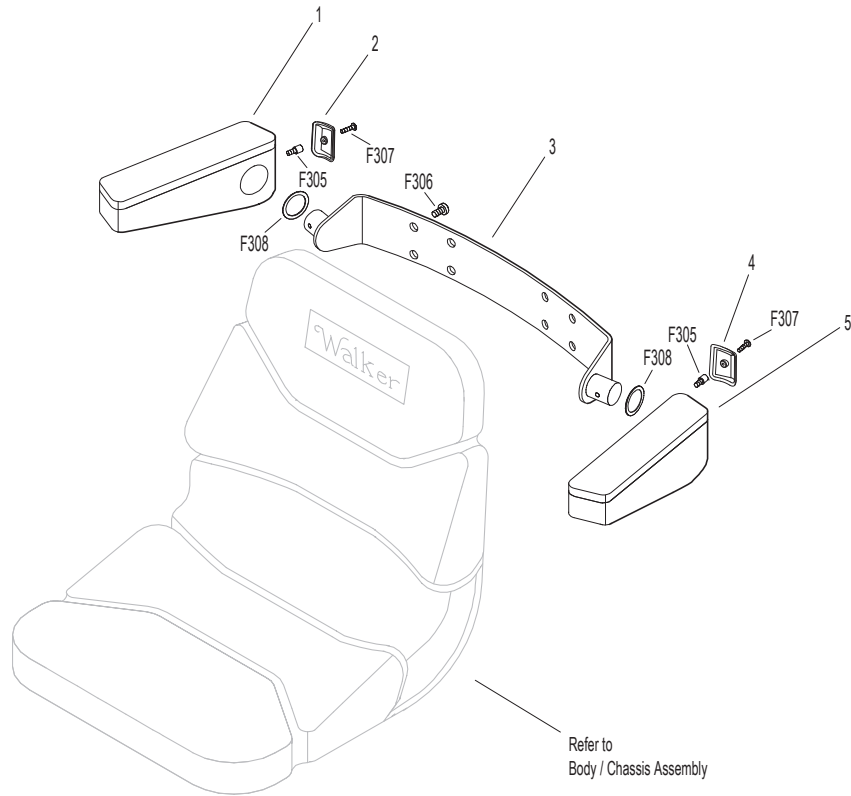

## COMFORT SEAT / ARMREST KIT

ITEM NO.	PART NO.	DESCRIPTION	NO. REQ'D
----------	----------	-------------	-----------

**Kit 6103-5 Comfort Seat Kit (Cordura)**

Includes Item # 1, fasteners listed and instructions. May be ordered as a dealer-installed option. Contact your Walker dealer.

1	6103-5	Comfort Seat	1
2	7203	Seat Spring Plate	*
3	7223-1	Compression Spring	*
4	7846	Washer (3/8 x 1-1/4 x 1/8)	*
5	5841-1	Retainer Washer	*
6	7845	Rubber Bumper (1.375 x .63)	*
7	7440-5	Shock Mount (1-1/4 x 3/4)	*

ITEM NO.	PART NO.	DESCRIPTION	NO. REQ'D
----------	----------	-------------	-----------

**Kit 6103-17 Armrest Option / Kit**

Includes Items # 8, 9 and instructions. Item # 8 is the **Right** side armrest only. Item # 9 is the **Left** side armrest only. Sold only as a complete set and may be ordered together as a kit for dealer installation. Contact your Walker dealer.

8	6103-42	Armrest, RH / Cordura	1
9	6103-41	Armrest, LH / Cordura	1

**Fasteners**

F009	5/16-18 Whiz Locknut	*
F227	3/8 x 1-1/4 x 1/8 Washer	*
F257	3/8 x 1-11/16 Shoulder Bolt	*

\* Reuse existing parts from Seat Assembly. Refer to **BODY / CHASSIS ASSEMBLY**, Page 4.

# COMFORT SEAT / ARMREST KIT

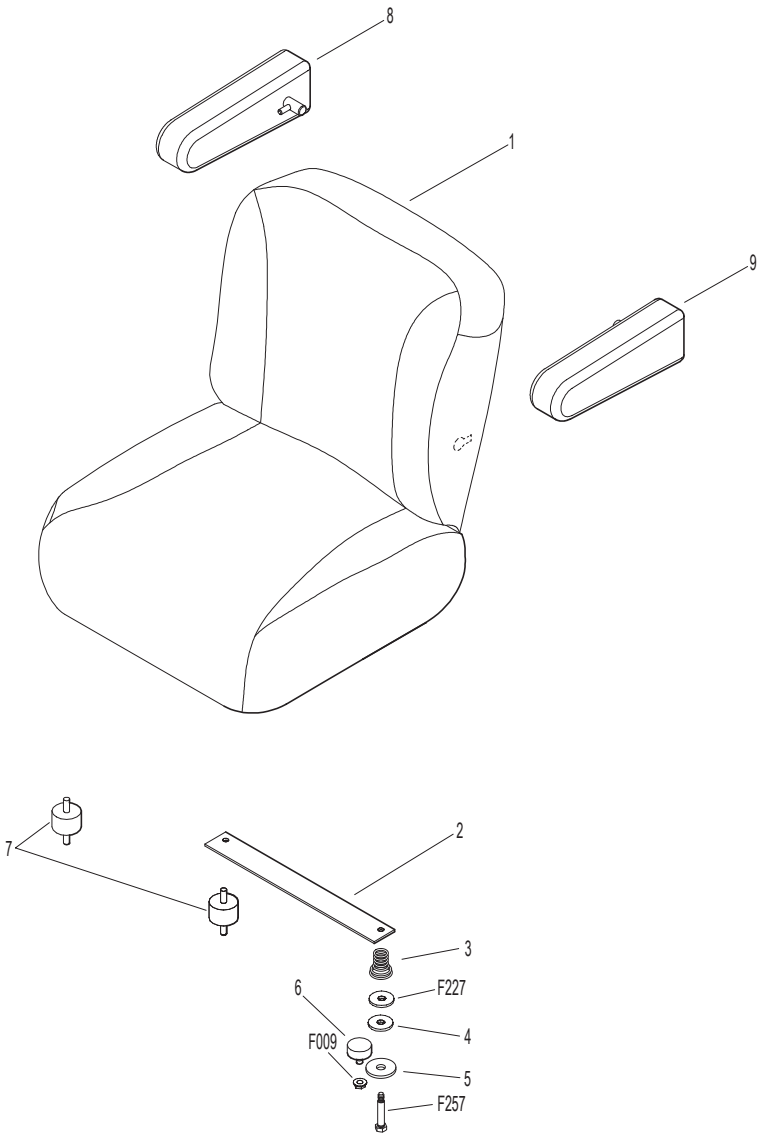

Beginning S/N 117172  
Effective Date 05-04-12  
Use only genuine **Walker**® replacement parts.

# LIGHT KIT

ITEM NO.	PART NO.	DESCRIPTION	NO. REQ'D	ITEM NO.	PART NO.	DESCRIPTION	NO. REQ'D
<b>Kit 5989-11 Light Option / Kit</b> Includes Items # 1-14, fasteners listed and instructions. May be ordered as a kit for dealer installation. Contact your Walker dealer.				6	7993-1	Mount Bracket, Light	1
				7	7995-4	Power Lead Wire Assembly (Includes Items # 5, 8, 9, 12 & 13)	1
				8	5977-1	Grommet (1/8 x 3/8)	2
1	7989-2	Light Assembly (Halogen) (Includes Items # 2 & 4) (Includes Halogen Bulb)	2	9	5975-1	Cable Tie (18# x 3-3/4")	1
	7989-6	Bulb Replacement (Halogen)	*	10	5995	Toggle Switch (Off-On)	1
2	7989-3	Wire Harness Extension	2	11	5995-2	Switch Boot	1
3	7834-2	Wire Saddle (2 Wires)	8	12	5996-1	16-14 GA Butt Connector	*
4	5996-4	16-14 GA Bullet Cntr. (M)	2	13	5996	1/4 x 16-14 GA QDF Terminal	*
5	5996-5	16-14 GA Bullet Cntr. (F)	2	14	6940-10	Jumper Wire	1

**Fasteners**

F009	5/16-18 Whiz Locknut	2
F052	5/16 Ext. Star Lock Washer	2
F091	5/16-18 x 5/8 Hex Bolt	2

\* Service Part Only

**NOTE:** Upon installation of kit, Item # 8 replaces P/N 5989-4 (Dome Plug, 3/8), and Item # F091 replaces P/N 5989-3 (Dome Plug, 5/16). Dome Plugs are not shown here. Refer to **BODY / CHASSIS ASSEMBLY**, Page 4.

**NOTE:** Refer to **ELECTRICAL CONNECTORS**, Page 28, for identification of all Electrical Wiring Service Parts.

# LIGHT KIT

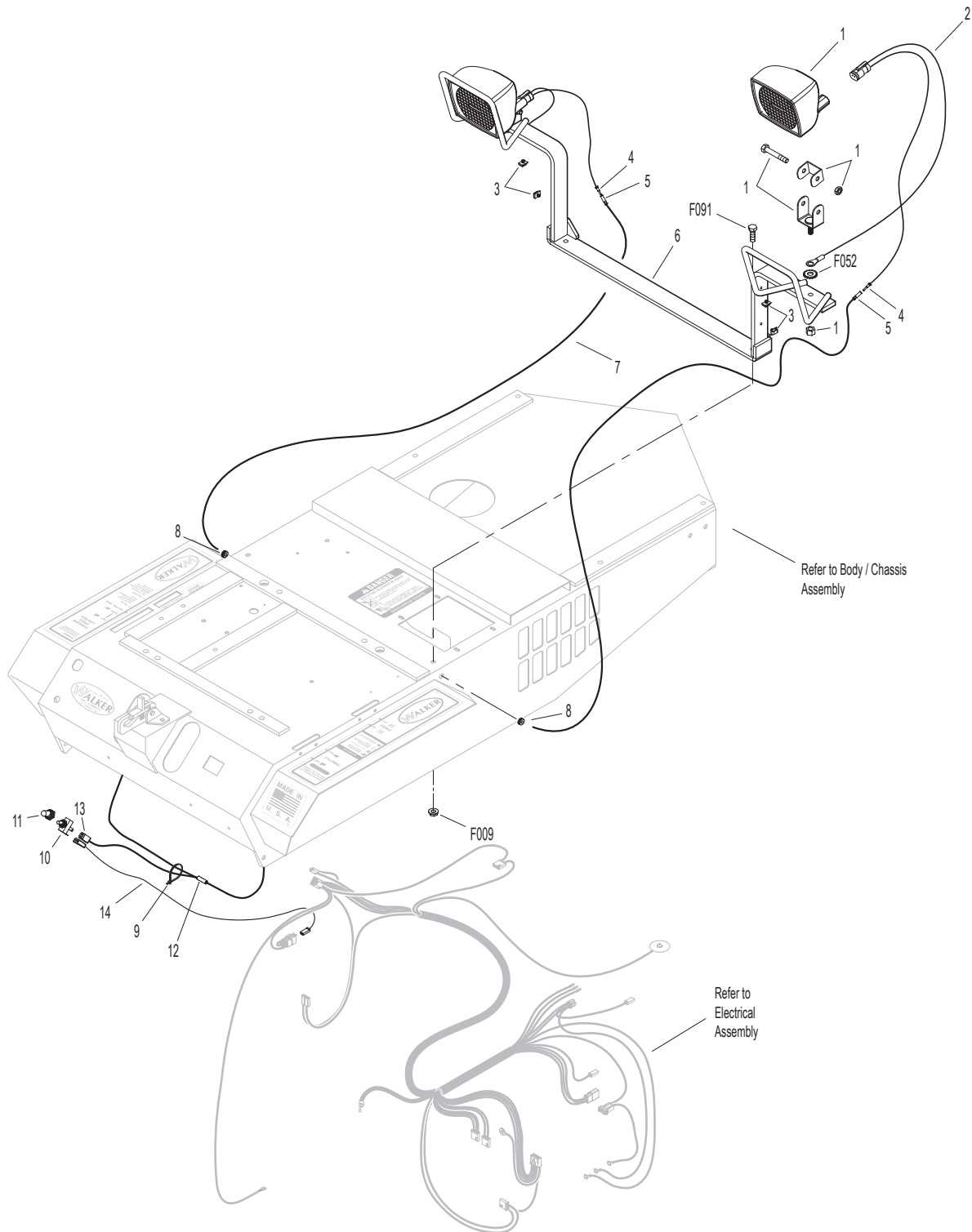

Beginning S/N 117172  
Effective Date 05-04-12  
Use only genuine Walker® replacement parts.

## NO CATCH DEFLECTOR KIT (6.7 BUSHEL)

ITEM NO.	PART NO.	DESCRIPTION	NO. REQ'D
----------	----------	-------------	-----------

**Kit 5500 No Catch Deflector Option / Kit (6.7 Bushel)**

Includes Items # 1-9, fasteners listed and instructions. May be ordered as a kit for dealer installation. Contact your Walker dealer.

1	8500-5	Side Bracket	2
2	8787-2	Knob, Threaded Insert (1/4-20)	1
3	5500	No Catch Deflector Kit (6.7)	1
4	8500-8	Decal, No Catch Deflector	1
5	8500-6	Spacer Lug	1
6	5500-8	Wire Assembly, No Catch Deflector (6.7)	1
7	5995	Toggle Switch (Off - On)	1
8	8500-9	Decal, Off - On	1
9	5995-2	Switch Boot	1

ITEM NO.	PART NO.	DESCRIPTION	NO. REQ'D
----------	----------	-------------	-----------

**Fasteners**

F002		10-24 Keps Nut	4
F030		1/4-20 x 1/2 PPH Bolt	1
F128		10-24 x 3/8 PTHMS	4
F146		1/4-20 Jam Nut	1
F333		1/4-20 x 3/4 PTHMS	1

**NOTE:** Refer to **ELECTRICAL CONNECTORS**, Page 28, for identification of all Electrical Wiring Service Parts.

# NO CATCH DEFLECTOR KIT (6.7 BUSHEL)

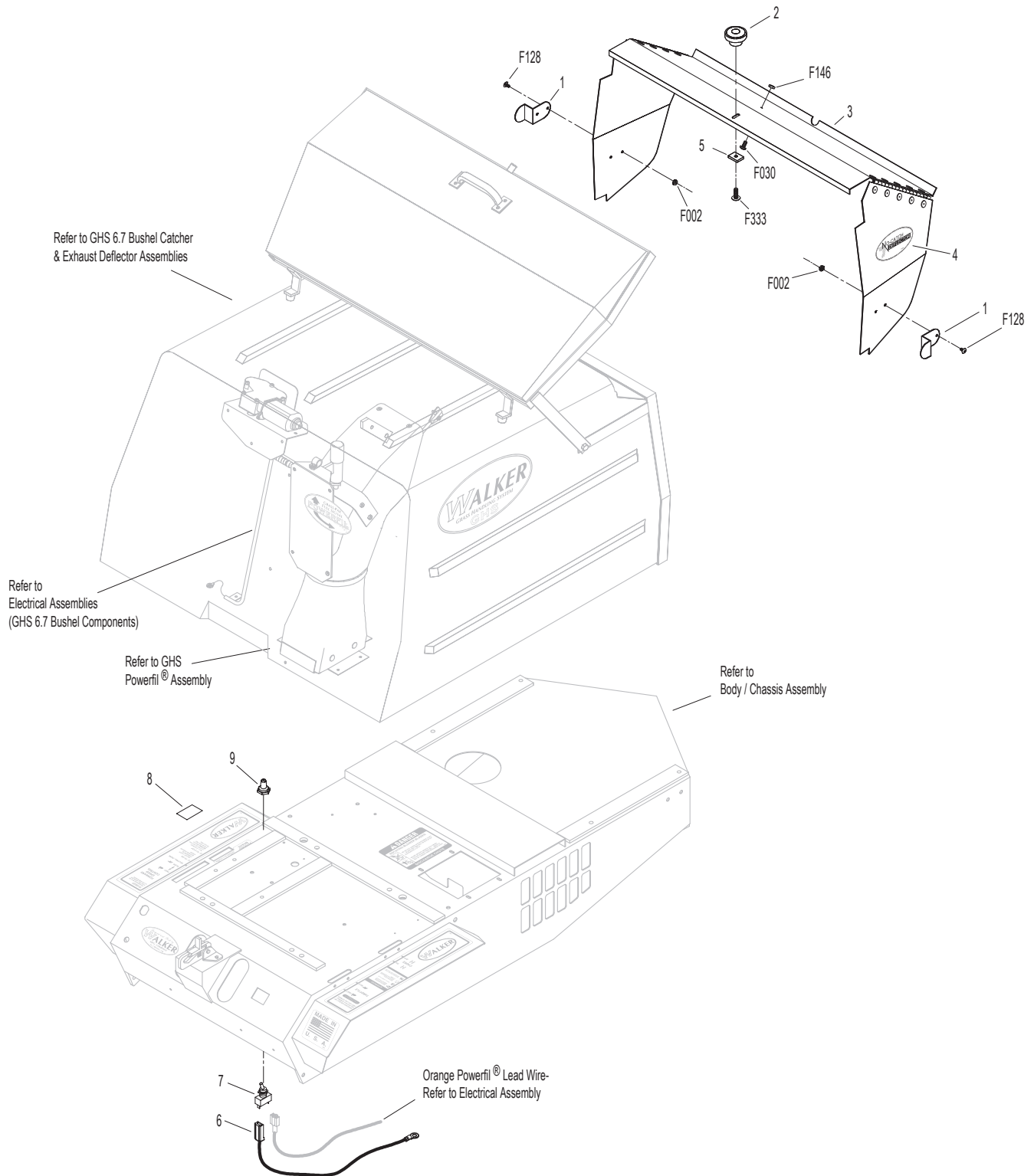

Beginning S/N 117172  
 Effective Date 05-04-12  
 Use only genuine **Walker**® replacement parts.

## OPTIONAL TIRES & TIRE CHAIN SETS

ITEM NO.	PART NO.	DESCRIPTION	NO. REQ'D
----------	----------	-------------	-----------

### Tire Chain Sets

May be ordered as a factory-installed option or as a kit for dealer installation. Contact your Walker dealer.

1	5675	Tire Chain Set (18 x 6.50-8) (Includes Item # 2) (For use with Standard Narrow Drive Tires)	1
	5675-2	Tire Chain Set (18 x 8.50-8) (Includes Item # 2) (For use with Wide Wheel & Tire Assy)	1
2	8070-31	Wheel Spacer Plate (1/2)	2

### Optional Wide Drive Tires

May be ordered as a kit for dealer installation. Contact your Walker dealer.

3	5070	Wheel & Tire (18 x 8.50-8)	2
	5070-2	Wide Tire (18 x 8.50-8)	*
	5070-4	Wide Wheel (8 x 7)	*

ITEM NO.	PART NO.	DESCRIPTION	NO. REQ'D
----------	----------	-------------	-----------

### Fasteners

F157		1/2-20 x 1-1/4 Wheel Lug Bolt	8
------	--	-------------------------------	---

\* Service Part Only

**NOTE:** Item F157 is reused from Body Assembly and is not included with this kit. Refer to **BODY / CHASSIS ASSEMBLY**, Page 4.



# OPTIONAL TIRES & TIRE CHAIN SETS

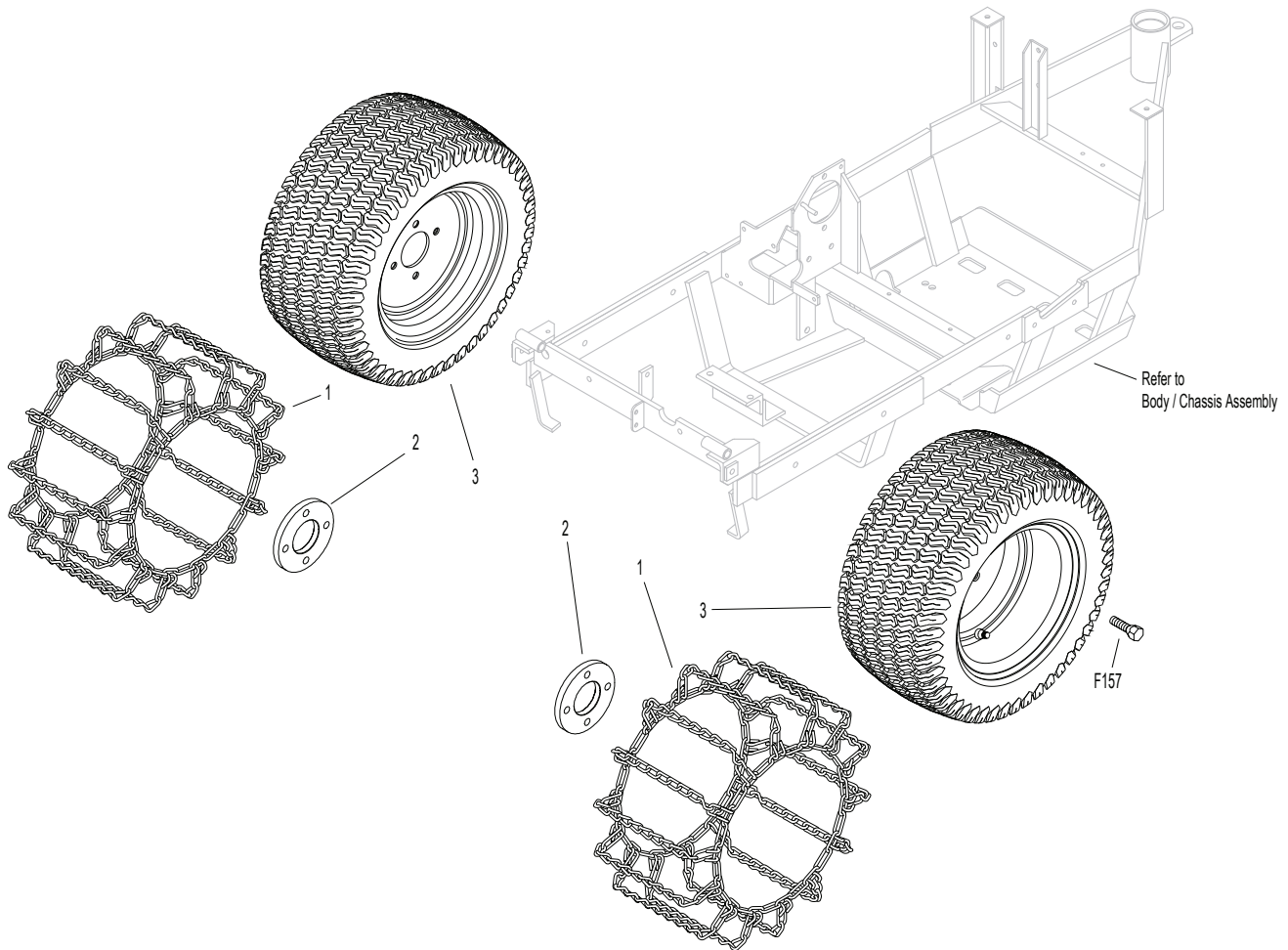

# LUBRICATION POINTS

ITEM NO.	LOCATION	LUBRICATION TYPE	NO. PLACES	ITEM NO.	LOCATION	LUBRICATION TYPE	NO. PLACES
<b>Lubrication Points</b>				18	Catcher Hinge Point	Oil	2
1	Steering Lever Pivot	Grease	4	19	Choke Control Cable Ends	Oil	2
2	Body Hinge Point	Oil	2	20	Throttle Control Cable Ends	Oil	2
3	FSC Actuator Rod Pivot Pins	Oil	2	21	Engine Belt Tightener Pivot	Grease	1
4	FSC Lever Pivot	Grease	1	22	Right Angle Gearbox, Tractor	Oil**	1
5	FSC Lever Fork (Grease Slide Area)	Grease	1	23	Hydrostatic Drive	Oil**	2
6	(FSC) Friction Body Pivot	Grease	1	24	Ground Drive Belt Tightener Pivot	Grease	1
7	Deck-to-PTO Coupling (Grease Spline Slide Area)	Grease	1	25	Choke Control Pivot	Oil	1
8	Deck Support Arm Pivot	Grease	2	26	Throttle Control Pivot	Oil	1
9	Universal Joint Tube Assembly	Grease*	1	* Grease every eight (8) hours.			
10	Parking Brake Lever	Grease	1	** Refer to <b>Gear Axle Lubrication, Engine Oil, Tractor PTO Gearbox Lubrication, and Hydrostatic Transmission Fluid</b> in Owner's Manual.			
11	Pillowblock Bearing, Drive Shaft	Grease***	2	*** Sealed, relubricatable-type bearings, grease lightly once per year, <b>do not over grease</b> or seals will be damaged.			
12	Gear Axle	Oil**	2	<b>NOTE:</b> See Model MS <b>Owner's Manual</b> (P/N 5000-23) for proper lubrication intervals.			
13	Clutch Control Lever Pivot	Grease	1				
14	Scrubber Brake Linkage	Oil	2				
15	Clutch Actuator Rod (Grease Slide Area)	Grease	1				
16	PTO Belt Tightener Pivot	Grease	1				
17	Engine Dipstick / Oil Filler	Oil**	1				

# LUBRICATION POINTS

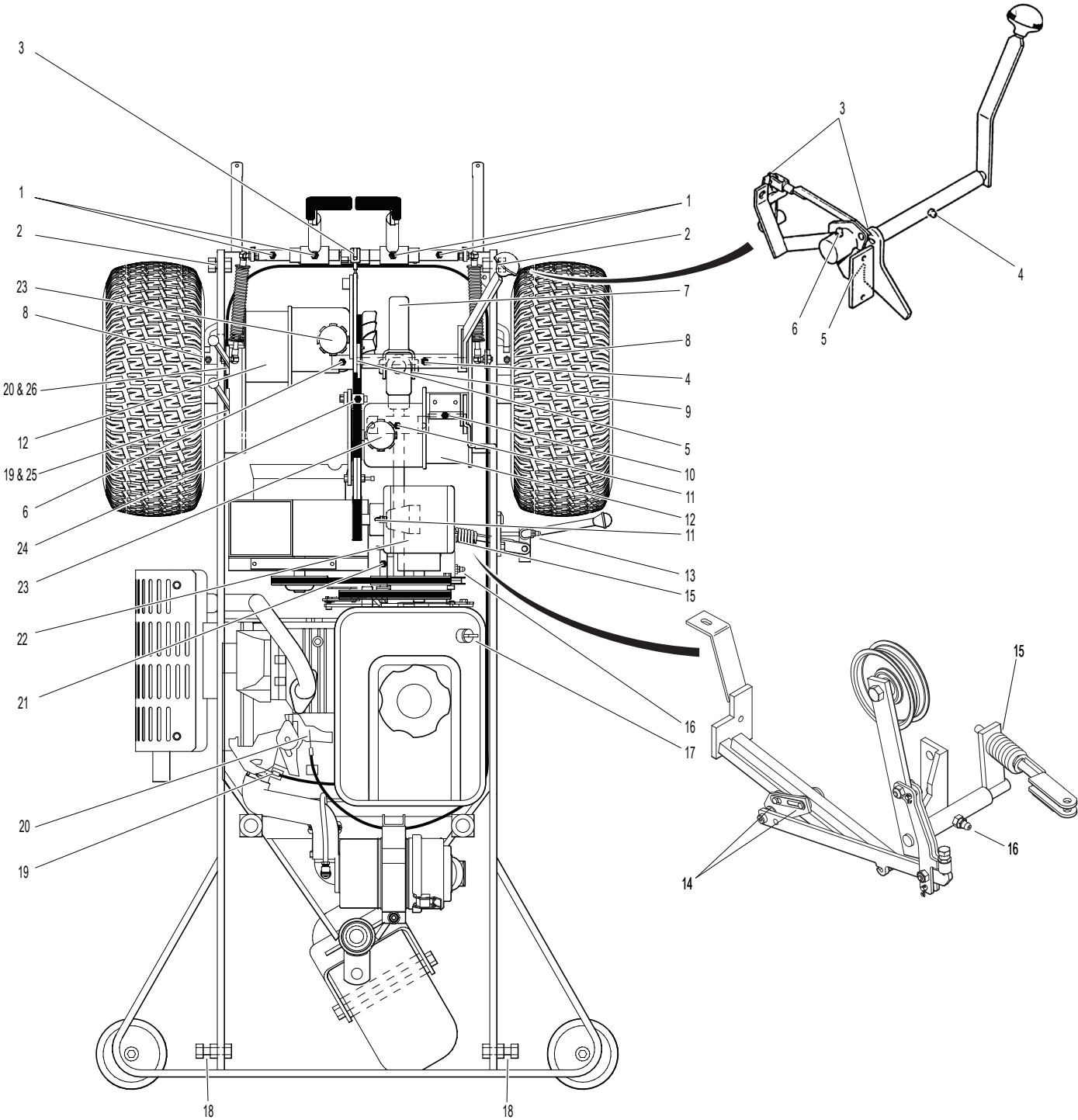

Beginning S/N 117172  
 Effective Date 05-04-12  
 Use only genuine **Walker**® replacement parts.

# WIRING SCHEMATIC

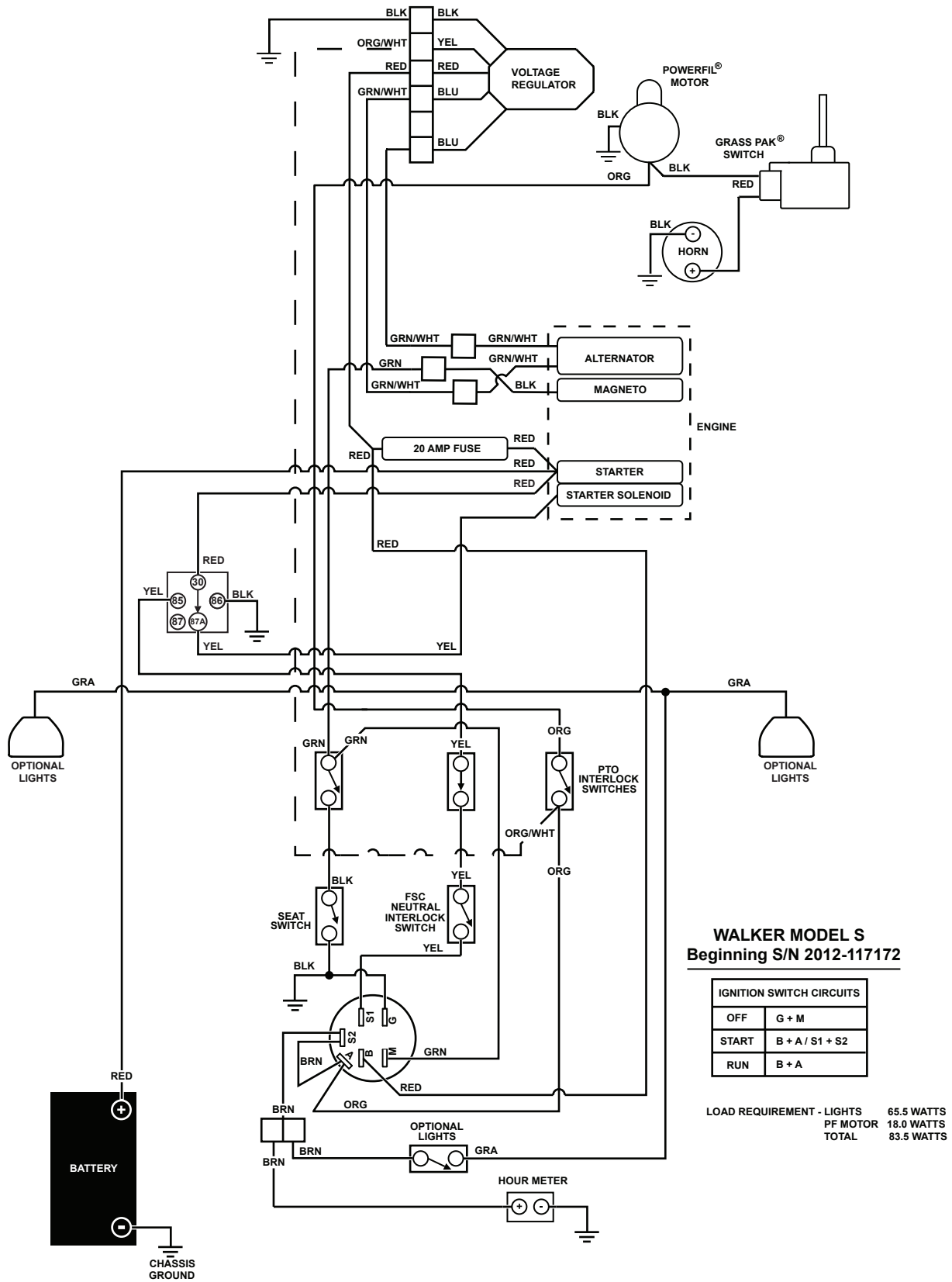

# OPERATOR'S NOTES

---

# OPERATOR'S NOTES

---

# LIMITED WARRANTY FOR WALKER COMMERCIAL RIDER MOWER

## 1. WHAT THIS WARRANTY COVERS, AND FOR HOW LONG:

Walker Manufacturing company will, at its option, repair or replace, without charge, any part covered by this warranty which is found to be defective in material and/or workmanship within one (1) year\* after date of sale to the original retail purchaser unless the product is used for rental purposes, in which case this warranty is limited to ninety (90) days. At Walker's request, customer will make the defective part available for inspection by Walker and/or return the defective part to Walker, transportation charges prepaid. All parts and components of the Walker Mower are covered by this warranty **except** the following components which are warranted separately by their respective manufacturers:

Subaru Engine  
Kohler Engine  
Kubota Engine  
Eaton Hydraulic Transmission  
Peerless Gearboxes  
Battery  
Tires

The available warranties covering these items are furnished with each mower. Walker does not assume any warranty obligation, liability or modification for these items, which are covered exclusively by the stated warranty of the respective manufacturers noted above.

\* An extended three (3) year warranty is offered on the Walker P/N 6200-9 Gear Axle Assembly.

## 2. WHAT THIS WARRANTY DOES NOT COVER:

- A. This warranty does not cover defects caused by depreciation or damage caused by normal wear, accidents, improper maintenance, improper use or abuse of the product, alterations, or failure to follow the instructions contained in the Operator's Manual for operation and maintenance.
- B. The customer shall pay any charges for making service calls and/or for transporting the mower to and from the place where the inspection and/or warranty work is performed.

## 3. HOW TO OBTAIN SERVICE UNDER THIS WARRANTY:

Warranty service can be arranged by contacting the dealer where you purchased the mower or by contacting Walker Manufacturing Company, 5925 East Harmony Road, Ft. Collins, CO 80528. Proof of the date of purchase may be required to verify warranty coverage.

## 4. WARRANTY LIMITATION:

- A. **THERE IS NO OTHER EXPRESS WARRANTY. ANY WARRANTY THAT MAY BE IMPLIED FROM THIS PURCHASE INCLUDING MERCHANTABILITY AND FITNESS FOR A PARTICULAR PURPOSE IS HEREBY LIMITED TO THE DURATION OF THIS WARRANTY AND TO THE EXTENT PERMITTED BY LAW ANY AND ALL IMPLIED WARRANTIES ARE EXCLUDED.** Some states do not allow limitations on how long an implied warranty lasts, so the above limitations may not apply to you.
- B. **WALKER WILL NOT BE LIABLE FOR ANY INCIDENTAL, CONSEQUENTIAL, OR SPECIAL DAMAGES AND/OR EXPENSES IN CONNECTION WITH THE PURCHASE OR USE OF THE MOWER.** Some states do not allow the exclusion or limitation of incidental or consequential damages, so the above limitation(s) or exclusion(s) may not apply to you.
- C. Only the warranty expressed in this limited warranty shall apply and no dealer, distributor, or individual is authorized to amend, modify, or extend this warranty in any way. Accordingly, additional statements such as dealer advertising or presentations, whether oral or written, do not constitute warranties by Walker, and should not be relied upon.
- D. This warranty gives you specific legal rights, and you may also have other rights which vary from state to state.

# WALKER MOWERS

WALKER MFG. CO. • 5925 E. HARMONY ROAD, FORT COLLINS, CO 80528 • (970) 221-5614  
FORM NO. 050412      PRINTED IN USA      [www.walkermowers.com](http://www.walkermowers.com)      ©2013 WALKER MFG. CO